

# 2981 AND 2982

## 8-CHANNEL SOURCE DRIVERS

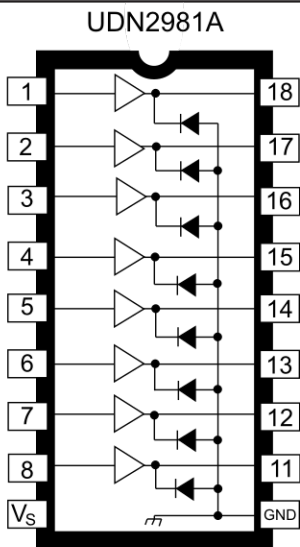

Dwg. No. A-10, 243

Note that the UDN2980A series (dual in-line package) and UDN2980LW series (small-outline IC package) are electrically identical and share a common terminal number assignment.

### ABSOLUTE MAXIMUM RATINGS at 25°C Free-Air Temperature

Output Voltage Range, $V_{CE}$ . . . . .	<b>5 V to 50 V</b>
Input Voltage, $V_{IN}$	
UDN2981A . . . . .	<b>15 V</b>
UDN2982A, UDN2982LW, and,	
A2982SLW . . . . .	<b>20 V</b>
Output Current, $I_{OUT}$ . . . . .	<b>-500 mA</b>
Package Power Dissipation,	
$P_D$ . . . . .	<b>See Graph</b>
Operating Temperature Range,	
$T_A$ . . . . .	<b>-20°C to +85°C</b>
Storage Temperature Range,	
$T_S$ . . . . .	<b>-55°C to +150°C</b>

Recommended for high-side switching applications that benefit from separate logic and load grounds, these devices encompass load supply voltages to 50 V and output currents to -500 mA. These 8-channel source drivers are useful for interfacing between low-level logic and high-current loads. Typical loads include relays, solenoids, lamps, stepper and/or servo motors, print hammers, and LEDs.

All devices may be used with 5 V logic systems — TTL, Schottky TTL, DTL, and 5 V CMOS. The UDN2981A, UDN2982A, and A2982SLW are electrically interchangeable, will withstand a maximum output off voltage of 50 V, and operate to a minimum of 5 V. All devices in this series integrate input current limiting resistors and output transient suppression diodes, and are activated by an active high input.

The suffix 'A' (all devices) indicates an 18-lead plastic dual in-line package with copper lead frame for optimum power dissipation. Under normal operating conditions, these devices will sustain 120 mA continuously for each of the eight outputs at an ambient temperature of +50°C and a supply of 15 V.

The suffix 'LW' (UDN2982LW only) indicates an 18-lead surface-mountable wide-body SOIC package; the A2982SLW is provided in a 20-lead wide-body SOIC package with improved thermal characteristics.

The UDN2982A, UDN2982LW, and A2982SLW drivers are also available for operation over an extended temperature range to -40°C. To order, change the prefix 'UDN' to 'UDQ' or the suffix 'SLW' to 'ELW'. These packages are available in Pb (lead) free variants (suffix '-T'), with 100% matte-tin leadframe plating.

### FEATURES

- TTL, DTL, PMOS, or CMOS Compatible Inputs
- 500 mA Output Source Current Capability
- Transient-Protected Outputs
- Output Breakdown Voltage to 50 V
- DIP or SOIC Packaging



Always order by complete part number, e.g., **UDN2981A**.  
Note that all devices are not available in all package styles.

# 2981 AND 2982 8-CHANNEL SOURCE DRIVERS

## One of Eight Drivers

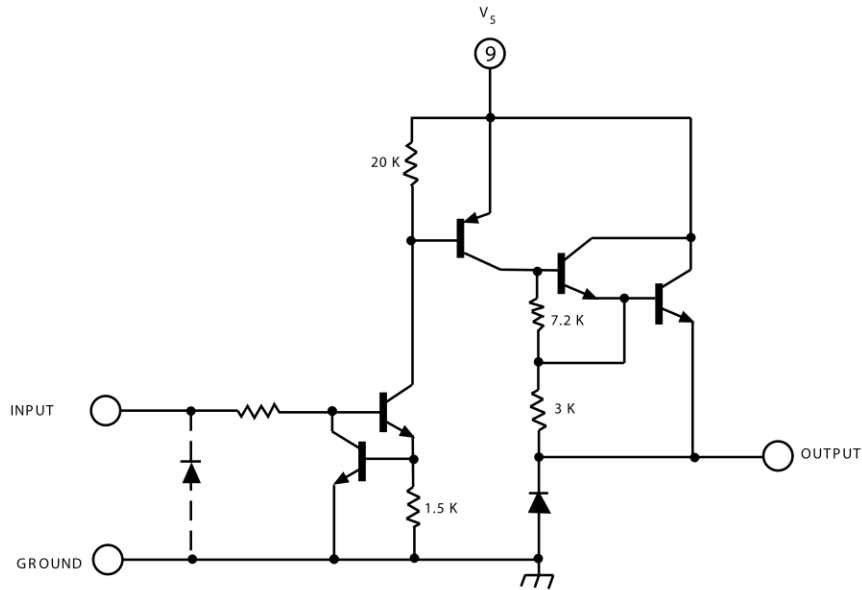

Dwg. No. A-10,242B

## A2982SLW

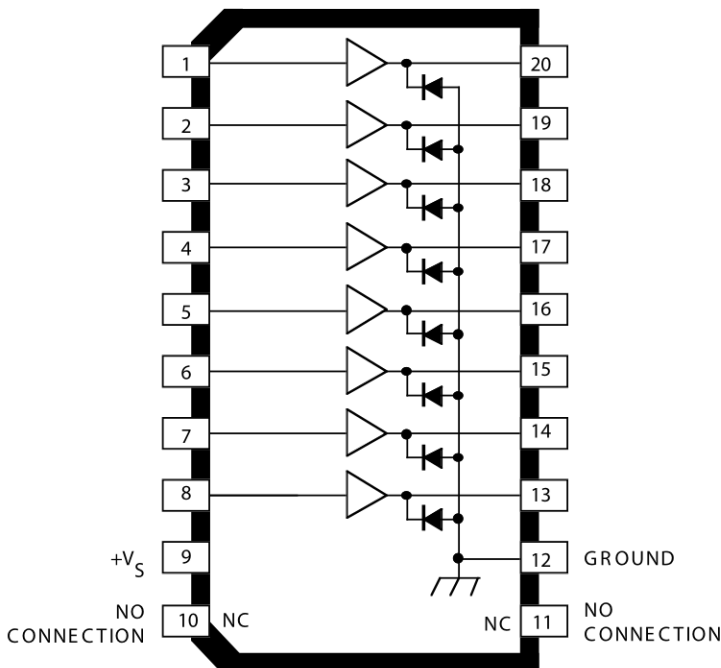

Dwg. PP-064-2

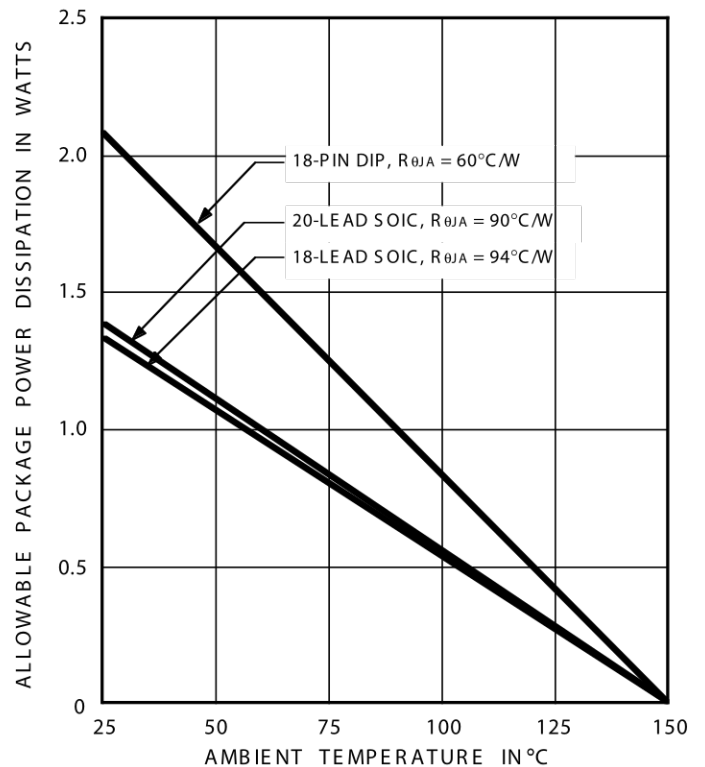

Dwg. GP-022-4A

# 2981 AND 2982 8-CHANNEL SOURCE DRIVERS

## ELECTRICAL CHARACTERISTICS at $T_A = +25^\circ\text{C}$ (unless otherwise specified).

Characteristic	Symbol	Applicable Devices	Test Conditions	Test Fig.	Limits			Units
					Min.	Typ.	Max.	
Output Leakage Current	$I_{CEX}$	All	$V_{IN} = 0.4\text{ V}^*$ , $V_S = 50\text{ V}$ , $T_A = +70^\circ\text{C}$	1	—	—	200	$\mu\text{A}$
Output Sustaining Voltage	$V_{CE(SUS)}$	All	$I_{OUT} = -45\text{ mA}$	—	35	—	—	V
Collector-Emitter Saturation Voltage	$V_{CE(SAT)}$	All	$V_{IN} = 2.4\text{ V}$ , $I_{OUT} = -100\text{ mA}$	2	—	1.6	1.8	V
			$V_{IN} = 2.4\text{ V}$ , $I_{OUT} = -225\text{ mA}$	2	—	1.7	1.9	V
			$V_{IN} = 2.4\text{ V}$ , $I_{OUT} = -350\text{ mA}$	2	—	1.8	2.0	V
Input Current	$I_{IN(ON)}$	UDN2981A	$V_{IN} = 2.4\text{ V}$	3	—	140	200	$\mu\text{A}$
			$V_{IN} = 3.85\text{ V}$	3	—	310	450	$\mu\text{A}$
		2982†	$V_{IN} = 2.4\text{ V}$	3	—	140	200	$\mu\text{A}$
			$V_{IN} = 12\text{ V}$	3	—	1.25	1.93	mA
Output Source Current (Outputs Open)	$I_{OUT}$	UDN2981A	$V_{IN} = 2.4\text{ V}$ , $V_{CE} = 2.0\text{ V}$	2	-350	—	—	mA
		2982†	$V_{IN} = 2.4\text{ V}$ , $V_{CE} = 2.0\text{ V}$	2	-350	—	—	mA
Supply Current Leakage Current	$I_S$	All	$V_{IN} = 2.4\text{ V}^*$ , $V_S = 50\text{ V}$	4	—	—	10	mA
Clamp Diode	$I_R$	All	$V_R = 50\text{ V}$ , $V_{IN} = 0.4\text{ V}^*$	5	—	—	50	$\mu\text{A}$
Clamp Diode	$V_F$	All	$I_F = 350\text{ mA}$	6	—	1.5	2.0	V
Turn-On Delay	$t_{ON}$	All	$0.5 E_{IN}$ to $0.5 E_{OUT}$ , $R_L = 100\Omega$ , $V_S = 35\text{ V}$	—	—	0.3	2.0	$\mu\text{s}$
Turn-Off Delay	$t_{OFF}$	All	$0.5 E_{IN}$ to $0.5 E_{OUT}$ , $R_L = 100\Omega$ , $V_S = 35\text{ V}$ , See Note	—	—	2.0	10	$\mu\text{s}$

NOTES: Turn-off delay is influenced by load conditions. Systems applications well below the specified output loading may require timing considerations for some designs, i.e., multiplexed displays or when used in combination with sink drivers in a totem pole configuration.

Negative current is defined as coming out of (sourcing) the specified device terminal.

\* All inputs simultaneously.

† Complete part number includes a prefix (A or UDN) and a suffix (A or SLW) as follows:  
UDN2981A, UDN2982A, UDN2982LW, or A2982SLW.

# 2981 AND 2982 8-CHANNEL SOURCE DRIVERS

## TEST FIGURES

Figure 1

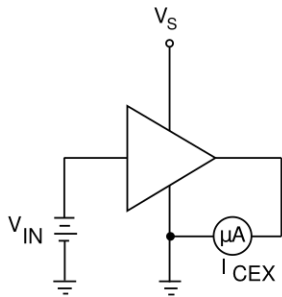

Dwg. No. A-11,083

Figure 2

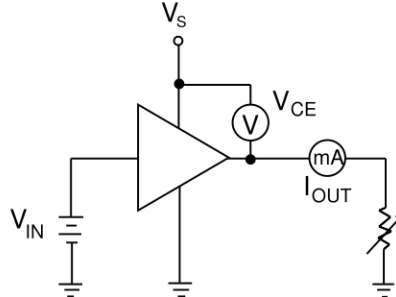

Dwg. No. A-11,084

Figure 3

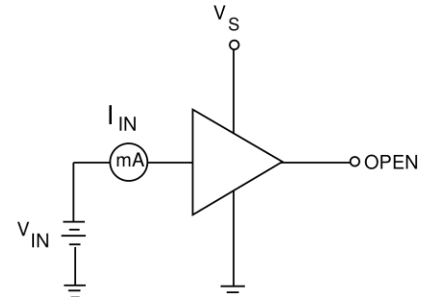

Dwg. No. A-11,085

Figure 4

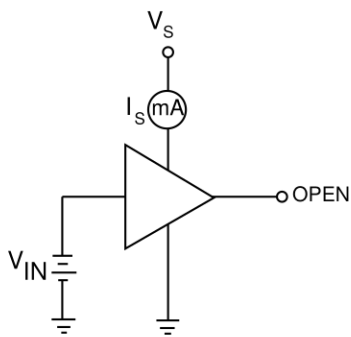

Dwg. No. A-11,086

Figure 5

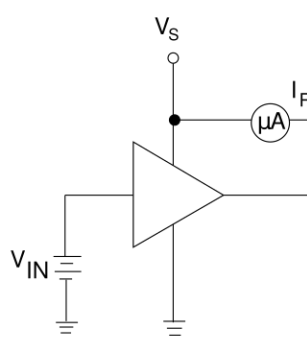

Dwg. No. A-11,087

Figure 6

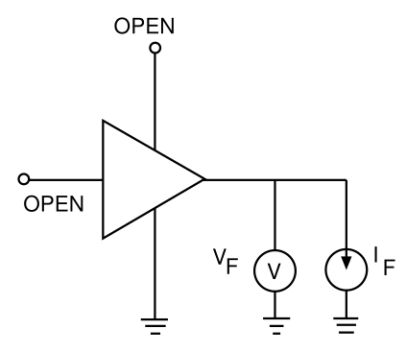

Dwg. No. A-11,088

# 2981 AND 2982 8-CHANNEL SOURCE DRIVERS

## Allowable peak collector current as a function of duty cycle

### Series UDN2980A

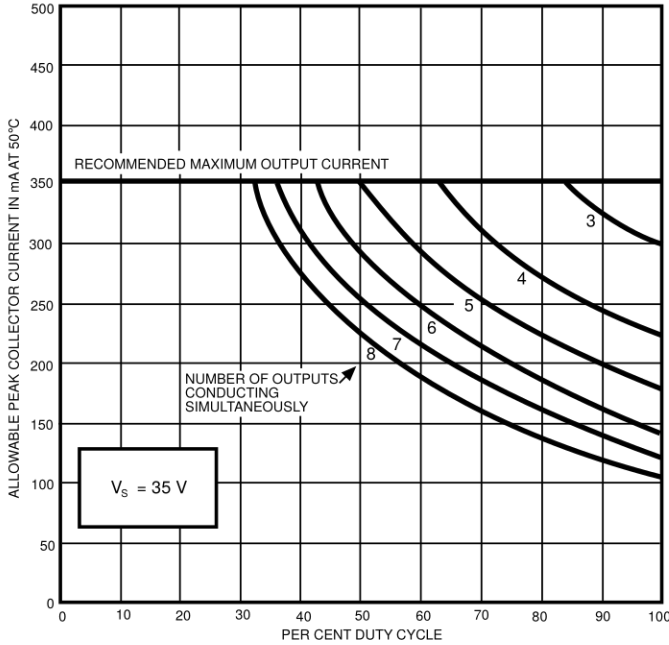

Dwg. No. A-11,106B

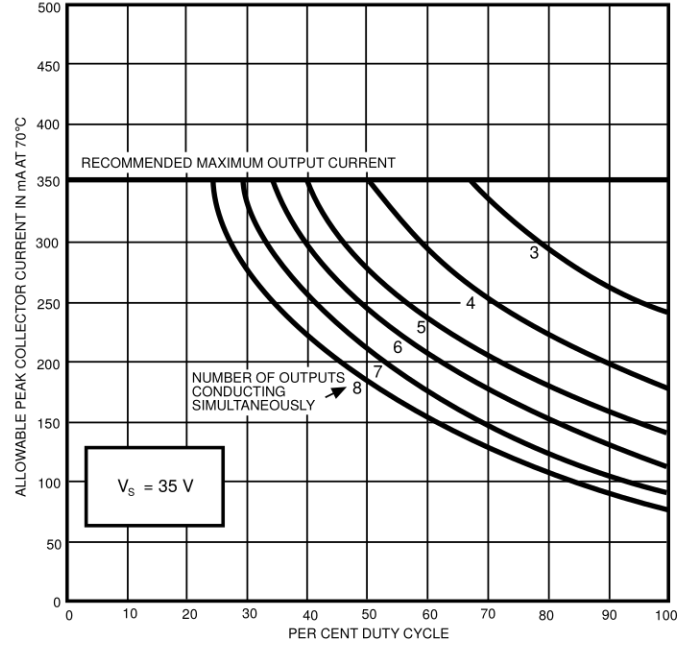

Dwg. No. A-11,111B

### UDN2981A and UDN2982A

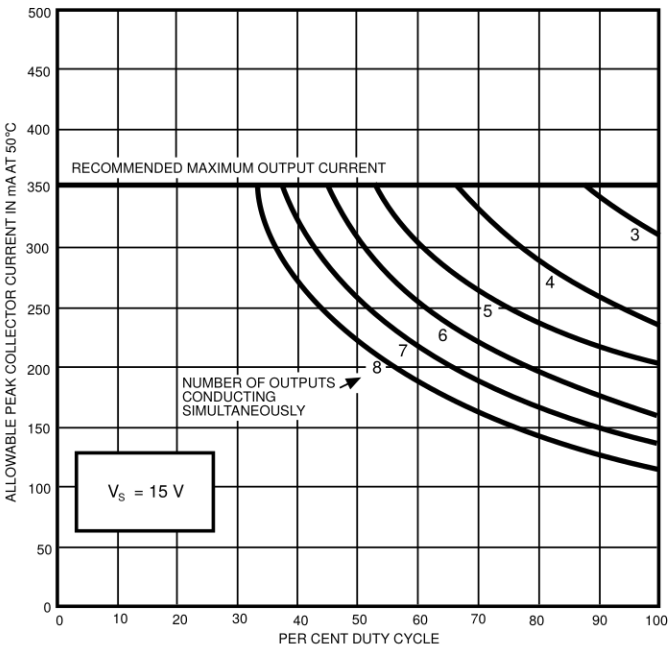

Dwg. No. A-11,107B

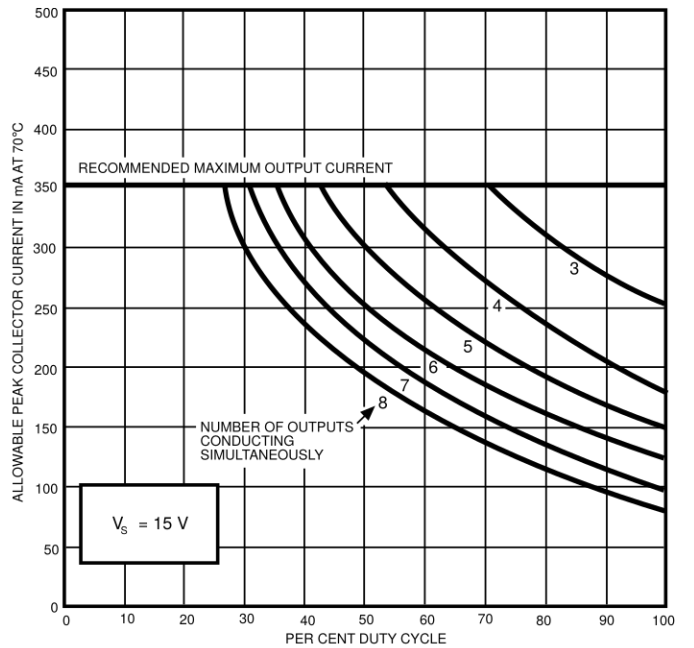

Dwg. No. A-11,108B

# 2981 AND 2982 8-CHANNEL SOURCE DRIVERS

Input current as a function of input voltage

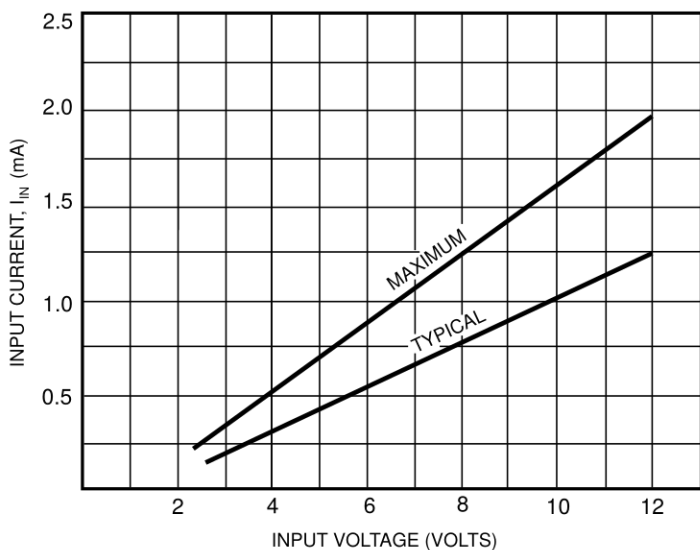

Dwg. No. A-11,115B

Typical electroensitive printer application

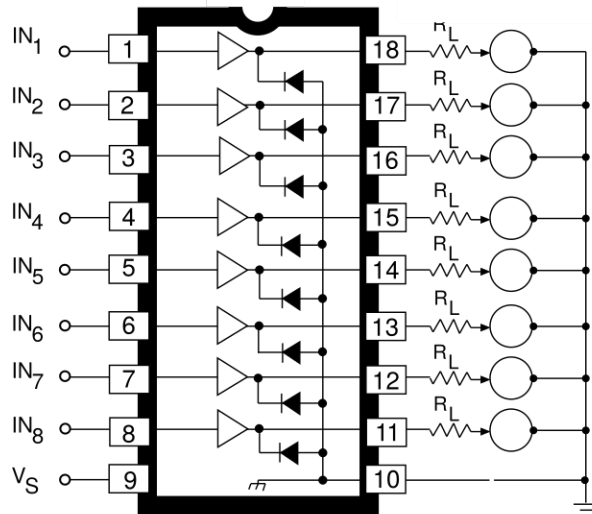

Dwg. No. A-11,113A

# 2981 AND 2982 8-CHANNEL SOURCE DRIVERS

## UDN2981A and UDN2982A

### Dimensions in Inches (controlling dimensions)

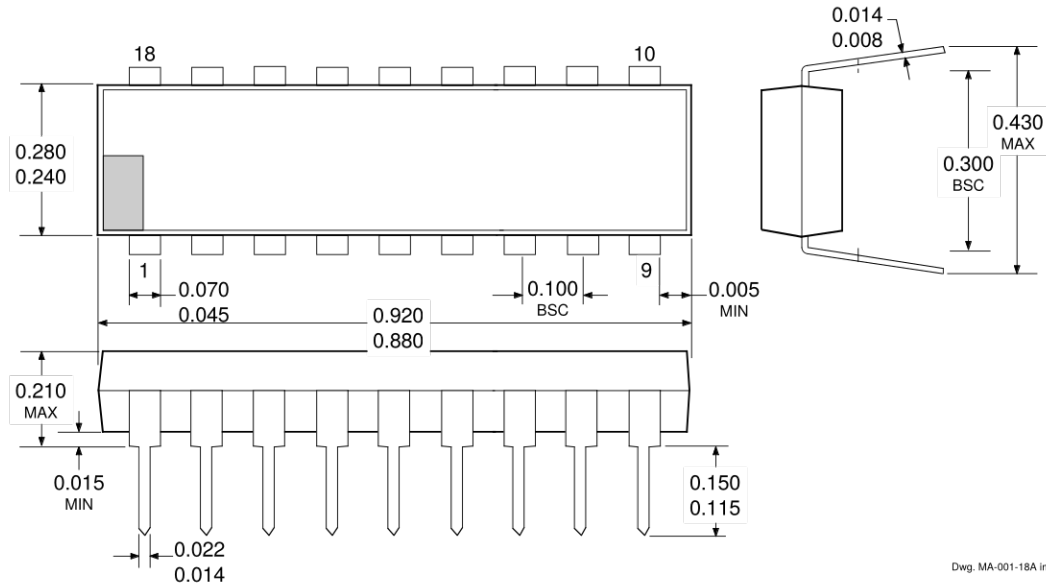

Dwg. MA-001-18A in

### Dimensions in Millimeters (for reference only)

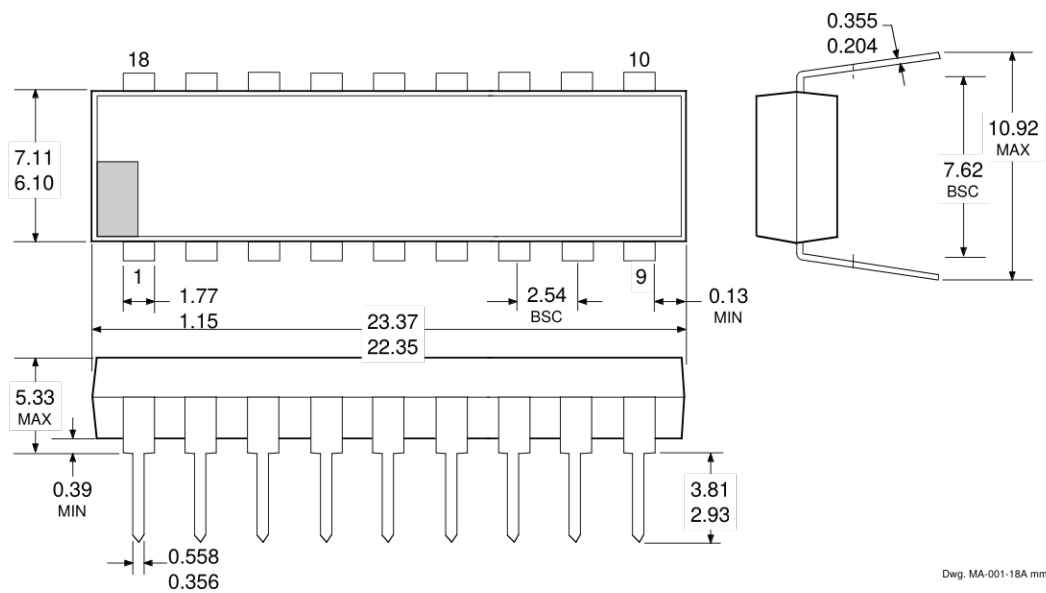

Dwg. MA-001-18A mm

- NOTES: 1. Exact body and lead configuration at vendor's option within limits shown.  
 2. Lead spacing tolerance is non-cumulative.  
 3. Lead thickness is measured at seating plane or below.  
 4. Supplied in standard sticks/tubes of 21 devices.

# 2981 AND 2982 8-CHANNEL SOURCE DRIVERS

## UDN2982LW

(add "TR" to part number for tape and reel)

### Dimensions in Inches (for reference only)

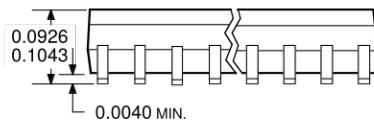
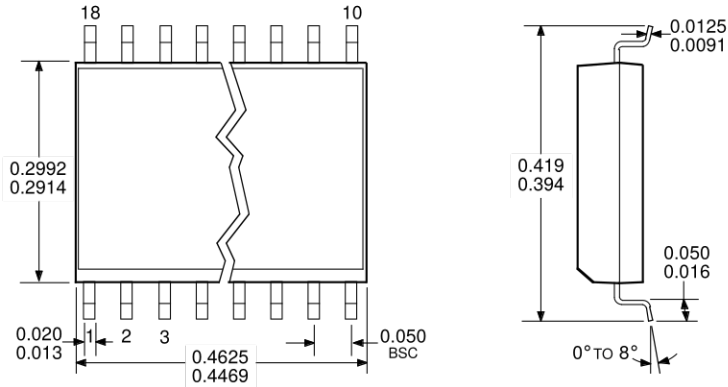

Dwg. MA-008-18A in

### Dimensions in Millimeters (controlling dimensions)

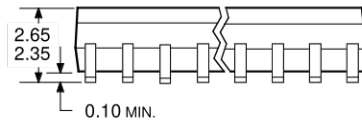
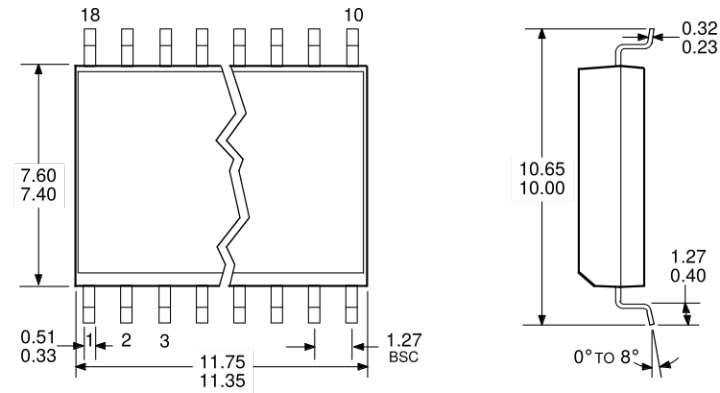

Dwg. MA-008-18A mm

- NOTES: 1. Exact body and lead configuration at vendor's option within limits shown.  
 2. Lead spacing tolerance is non-cumulative.  
 3. Supplied in standard sticks/tubes of 41 devices or add "TR" to part number for tape and reel.



# 2981 AND 2982 8-CHANNEL SOURCE DRIVERS

## A2982SLW

(add "TR" to part number for tape and reel)

### Dimensions in Inches

(for reference only)

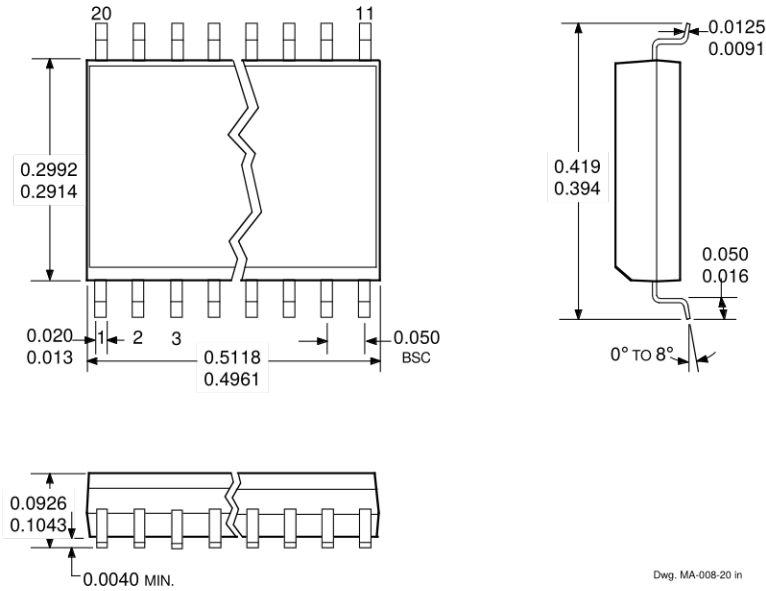

### Dimensions in Millimeters

(controlling dimensions)

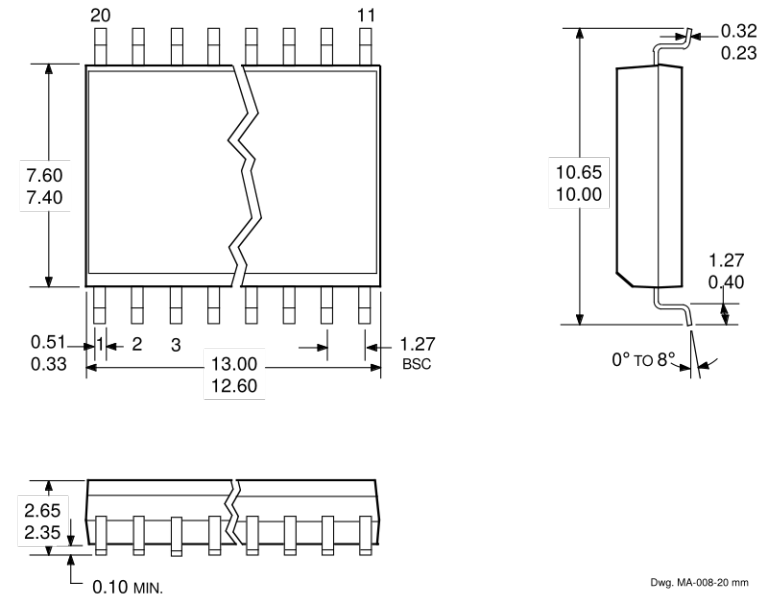

- NOTES: 1. Exact body and lead configuration at vendor's option within limits shown.  
 2. Lead spacing tolerance is non-cumulative.  
 3. Supplied in standard sticks/tubes of 37 devices or add "TR" to part number for tape and reel.

**2981 AND 2982**  
**8-CHANNEL**  
**SOURCE DRIVERS**

*The products described here are manufactured under one or more U.S. patents or U.S. patents pending.*

*Allegro MicroSystems, Inc. reserves the right to make, from time to time, such departures from the detail specifications as may be required to permit improvements in the performance, reliability, or manufacturability of its products. Before placing an order, the user is cautioned to verify that the information being relied upon is current.*

*Allegro products are not authorized for use as critical components in life-support devices or systems without express written approval.*

*The information included herein is believed to be accurate and reliable. However, Allegro MicroSystems, Inc. assumes no responsibility for its use; nor for any infringement of patents or other rights of third parties which may result from its use.*