

DABIC-5 8-Channel Source Driver with Overcurrent Protection

Features and Benefits

- 4.75 to 35 V driver supply voltage
- Output enable-disable (OE/R)
- 350 mA output source current
- Overcurrent protected
- Internal ground clamp diodes
- Output Breakdown Voltage 35 V minimum
- TTL, DTL, PMOS, or CMOS compatible inputs
- Internal Thermal Shutdown (TSD)

Packages:

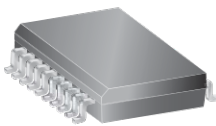

20-pin SOICW
(LW package)



20-pin DIP
(A package)

Description

Providing overcurrent protection for each of its eight sourcing outputs, the UDN2987A-6 and UDN2987LW-6 drivers are used as an interface between standard low-level logic and relays, motors, solenoids, LEDs, and incandescent lamps. These devices include thermal shut down and output transient protection/clamp diodes for use with sustaining voltages to 35 V.

In these drivers, each channel includes a latch to turn off that channel if the maximum channel current is exceeded. All channels are disabled if the thermal shutdown is activated. A common FAULT output is used to indicate either chip thermal shutdown or any overcurrent condition. All outputs are enabled by pulling the common OE/R input high. When OE/R is low, all outputs are inhibited and the eight latches are reset. The OE/R function can be especially important during power-up, in preventing floating inputs from turning on the outputs.

Under normal operating conditions, each of eight outputs will source in excess of 100 mA continuously at an ambient temperature of 25°C and a supply of 35 V. The overcurrent

Continued on the next page...

Not to scale

Typical Application

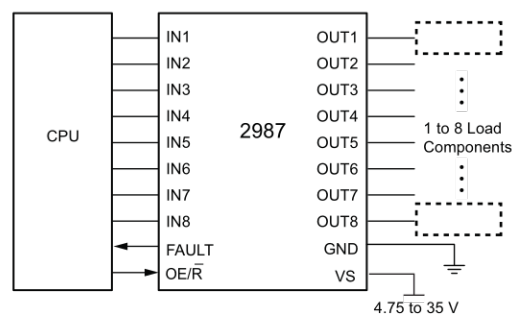

Description (continued)

fault circuit will protect the device from short-circuits to ground with supply voltages of up to 30 V.

The inputs are compatible with 5 and 12 V logic systems: TTL, Schottky TTL, DTL, PMOS, and CMOS. In all cases, the output is switched ON by an active high input level. Compared to their predecessor devices, the UDN2987A and UDN2987LW, the

UDN2987A-6 and UDN2987LW-6 have a significantly faster T_{PHL} (200 ns typical) and a lower driver supply voltage rating (4.75 V), which allows the use of 5 V logic.

The UDN2987A-6 is supplied in a 20-pin dual in-line plastic (DIP) package; the UDN2987LW-6 is supplied in a 20-lead small-outline (SOIC-W) plastic package. All packages are lead (Pb) free, with 100% matte-tin leadframe plating.

Selection Guide

Part Number	Packing	Package
UDN2987A-6-T	18 pieces/tube	20-pin DIP
UDN2987LWTR-6-T	1000 pieces/13-in. reel	20-pin SOIC, wide body

Absolute Maximum Ratings

Parameter	Symbol	Notes	Rating	Units
Supply Voltage	V_S		35	V
Continuous Output Current*	I_{OUT}	Outputs are disabled at approximately -500 mA	-500	mA
FAULT Output Voltage	V_{CE}		35	V
FAULT Output Current	I_C		30	mA
Input Voltage	V_{IN}		-0.3 to 14	V
Junction Temperature	T_J		150	°C
Storage Temperature Range	T_S	Range N	-55 to 150	°C
Operating Temperature Range	T_A		-20 to 85	°C

*For input and output current specifications, negative current is defined as coming out of (sourcing) the specified device pin.

Functional Block Diagram

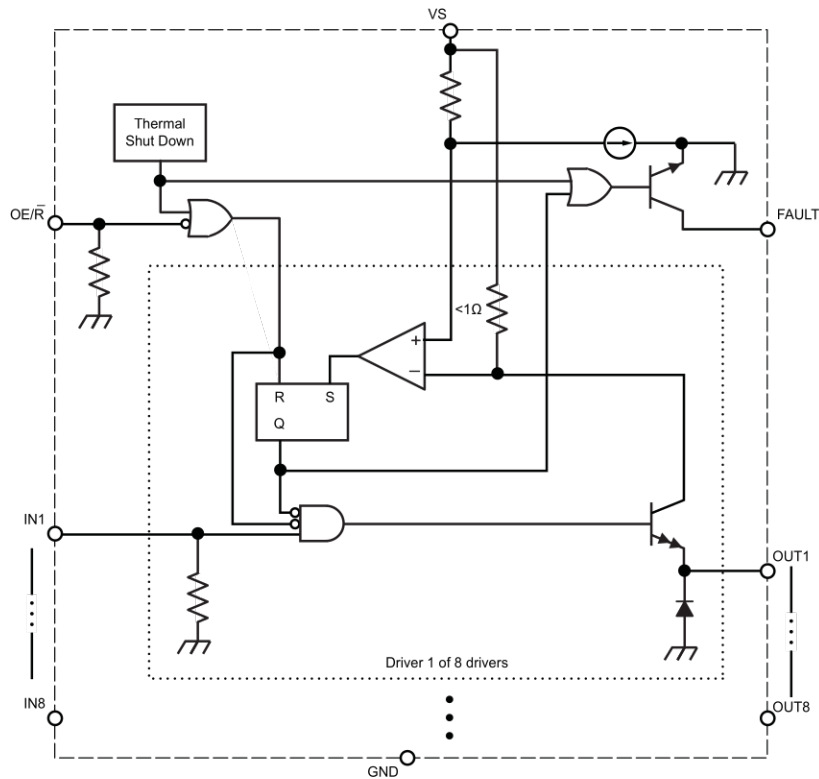

Pin-Out Diagram

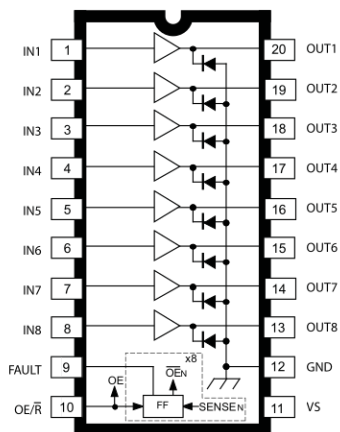

Dwg. PP-067

Package A (DIP) shown. Package LW (SOIC-W) is electrically identical and has the same terminal number assignment.

Terminal List Table

Number	Name	Description
1	IN1	Logic input 1
2	IN2	Logic input 2
3	IN3	Logic input 3
4	IN4	Logic input 4
5	IN5	Logic input 5
6	IN6	Logic input 6
7	IN7	Logic input 7
8	IN8	Logic input 8
9	FAULT	Fault output
10	OE/R	Logic input for Output Enable and Reset
11	VS	Supply voltage
12	GND	Supply ground
13	OUT8	Output 8 to load
14	OUT7	Output 7 to load
15	OUT6	Output 6 to load
16	OUT5	Output 5 to load
17	OUT4	Output 4 to load
18	OUT3	Output 3 to load
19	OUT2	Output 2 to load
20	OUT1	Output 1 to load

ELECTRICAL CHARACTERISTICS, valid at $T_A = 25^\circ\text{C}$, $V_{\text{OER}} = 2.4\text{ V}$, $V_S = 35\text{ V}$, unless otherwise noted

Characteristic	Symbol	Test Conditions	Min.	Typ. ¹	Max.	Units
Supply Voltage Functional Range	V_S		4.75	—	35	V
Output Leakage Current ²	I_{OUTCEX}	$V_{\text{IN}} = 0.4\text{ V}$, all inputs simultaneously	-200	<-5.0	-	μA
Output Sustaining Voltage	$V_{\text{OUT(SUS)}}$	$I_{\text{OUT}} = -350\text{ mA}$, $L = 2.0\text{ mH}$	35	—	—	V
Output Saturation Voltage	$V_{\text{OUT(SAT)}}$	$V_{\text{IN}} = 2.4\text{ V}$, $I_{\text{OUT}} = -100\text{ mA}$	—	1.6	1.8	V
		$V_{\text{IN}} = 2.4\text{ V}$, $I_{\text{OUT}} = -225\text{ mA}$	—	1.7	1.9	V
		$V_{\text{IN}} = 2.4\text{ V}$, $I_{\text{OUT}} = -350\text{ mA}$	—	1.8	2.0	V
Channel Shut Down Threshold ²	I_M	$V_{\text{IN}} = 2.4\text{ V}$, $V_S = 30\text{ V}$	-	-500	-370	mA
FAULT Leakage Current	I_{CEX}	$V_{\text{CC}} = 35\text{ V}$	—	<1.0	100	μA
FAULT Saturation Voltage	$V_{\text{CE(SAT)}}$	$I_C = 30\text{ mA}$	—	0.3	0.8	V
Input Voltage	$V_{\text{IN(ON)}}$		2.4	—	—	V
	$V_{\text{IN(OFF)}}$		—	—	0.4	V
Input Current: INx, OE/ \bar{R} pins	$I_{\text{IN(ON)}}$	$V_{\text{IN}} = 2.4\text{ V}$	—	—	100	μA
		$V_{\text{IN}} = 5.0\text{ V}$	—	—	600	μA
		$V_{\text{IN}} = 12\text{ V}$	—	—	1000	μA
	$I_{\text{IN(OFF)}}$	$V_{\text{IN}} = 0.4\text{ V}$	—	—	15	μA
Clamp Diode Leakage Current	I_R	$V_R = 35\text{ V}$, $T_A = 70^\circ\text{C}$	—	—	50	μA
Clamp Diode Forward Voltage	V_F	$I_F = 350\text{ mA}$	—	1.5	1.8	V
Supply Current	$I_{\text{S(ON)}}$	$V_{\text{IN}} = 2.4\text{ V}$, all inputs simultaneously; outputs open	—	7.0	18	mA
	$I_{\text{S(OFF)}}$	$V_{\text{IN}} = 0.4\text{ V}$, all inputs simultaneously	—	6.0	12	mA
Thermal Shut Down	T_{JTSD}		—	165	—	$^\circ\text{C}$
Thermal Hysteresis	T_{JTSDhys}		—	15	—	$^\circ\text{C}$
Reset Pulse Duration	t_{RPD}		1.0	—	—	μs
Propagation Delay Time	t_{PLH}	$V_S = 35\text{ V}$, $R_L = 100\ \Omega$, $C_{\text{LOAD}} = 30\text{ pF}$	—	100	600	ns
	t_{PHL}	$V_S = 35\text{ V}$, $R_L = 100\ \Omega$, $C_{\text{LOAD}} = 30\text{ pF}$	—	200	1000	ns
Blank Time	t_{BLANK}		—	1.0	—	μs

¹Typical data are for initial design estimations only, and assume optimum manufacturing and application conditions. Performance may vary for individual units, within the specified maximum and minimum limits.

²For input and output current specifications, negative current is defined as coming out of (sourcing) the specified device pin.

THERMAL CHARACTERISTICS

Characteristics	Symbol	Test Conditions	Rating	Unit
Package Thermal Resistance*	$R_{\theta JA}$	Package A, on 4-layer board based on JEDEC standard	32	°C/W
		Package LW, on 4-layer board based on JEDEC standard	48	°C/W

*Additional thermal information is available on the Allegro Web site.

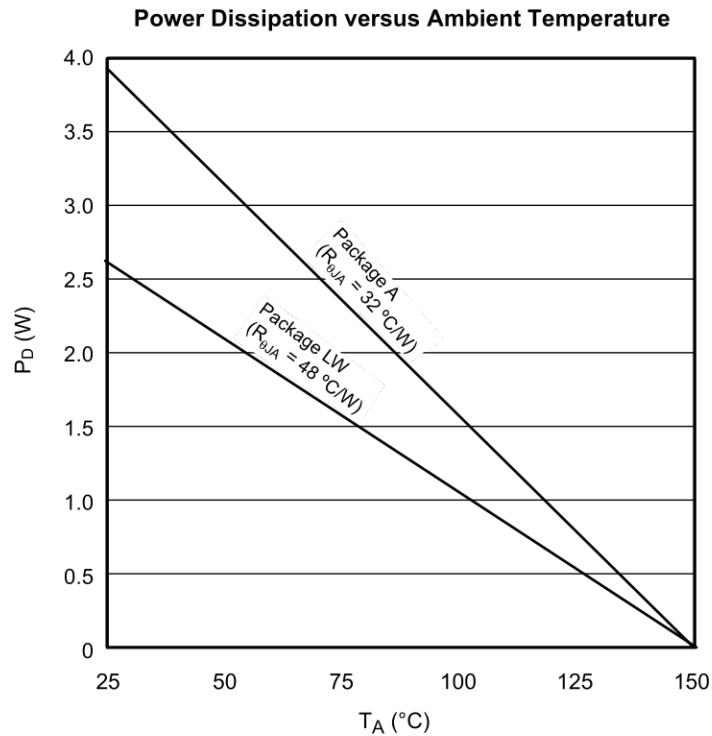

Characteristic Performance

Output Current Waveshapes

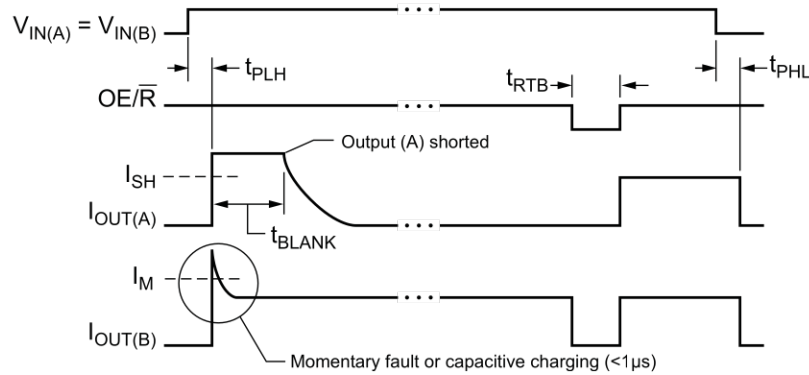

Allowable Output Current as a Function of Duty Cycle

(UDN2987A-6 shown, multiply by 78% for UDN2987LW-6)

$T_A = 25^\circ\text{C}, V_S = 35\text{ V}$

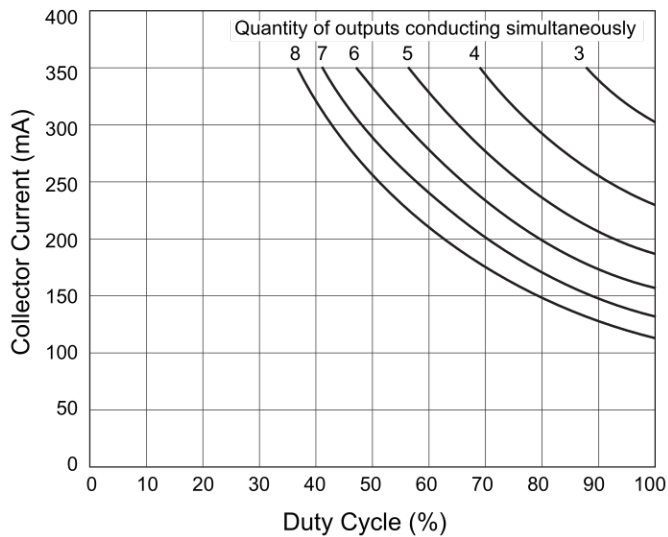

$T_A = 50^\circ\text{C}, V_S = 35\text{ V}$

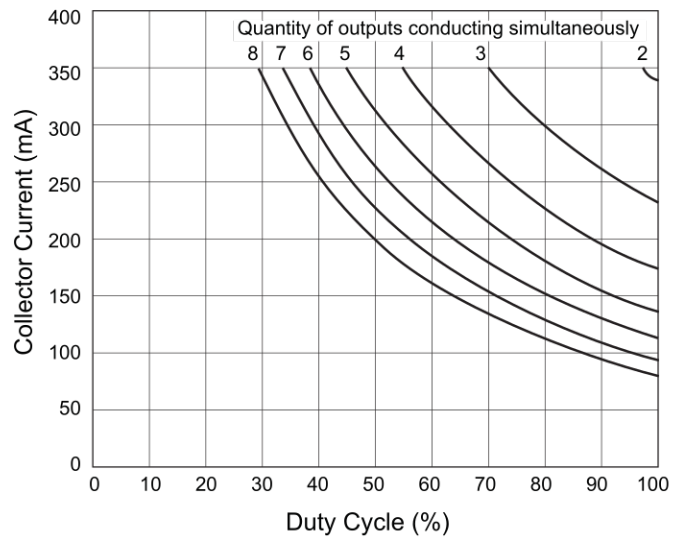

Applications Information and Circuit Description

As with all power integrated circuits, the UDN2987A-6 and UDN2987LW-6 have a maximum allowable output current rating. The 500 mA rating does not imply that operation at that value is permitted or even obtainable. The channel output current trip point is specified as -370 mA, minimum; therefore, attempted operation at current levels greater than -370 mA may cause a fault indication and channel shut down. The device is tested at a maximum of -350 mA and that is the recommended maximum output current per driver. It provides protection for current overloads or shorted loads up to 30 V.

All outputs are enabled by pulling the $\text{OE}/\bar{\text{R}}$ input high. When $\text{OE}/\bar{\text{R}}$ is low or allowed to float (internal pull-down), all outputs are inhibited and the latches are reset. Note that the reset pulse duration ($\text{OE}/\bar{\text{R}}$ low) should be at least $1 \mu\text{s}$. This will ensure safe operation under attempted reset conditions with a shorted load. The latches are also reset during power-up, regardless of the state of the $\text{OE}/\bar{\text{R}}$ input.

The load current causes a small voltage drop across the internal low-value sense resistor. This voltage is com-

pared to the voltage drop across a reference resistor with a constant current. The two resistors are matched to eliminate errors due to manufacturing tolerances or temperature effects. Each channel includes a comparator and its own latch. An overcurrent fault ($V_{\text{SENSE}} > V_{\text{REF}}$) will set the affected latch and shut down only that channel. All other channels will continue to operate normally. The latch includes a $1 \mu\text{s}$ blanking delay, t_{BLANK} , to prevent unwanted triggering due to crossover currents generated when switching inductive loads. For an abrupt short circuit, the blanking and output switching times will allow a brief, permissible current in excess of the trip current before the output driver is turned off.

A common thermal shut down disables all outputs if the chip temperature exceeds 165°C . At thermal shut down, all latches are reset. The outputs are disabled until the chip cools down to approximately 150°C (thermal hysteresis).

In the event of an overcurrent condition on any channel, or chip thermal shut down, the FAULT open-collector output is pulled low (turned on).

Overcurrent Fault Sense Circuit

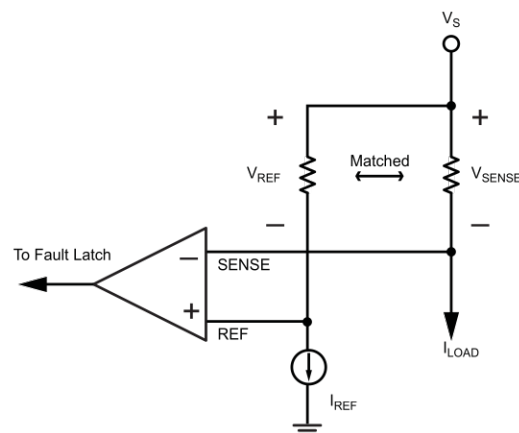

Package A, 20-Pin DIP

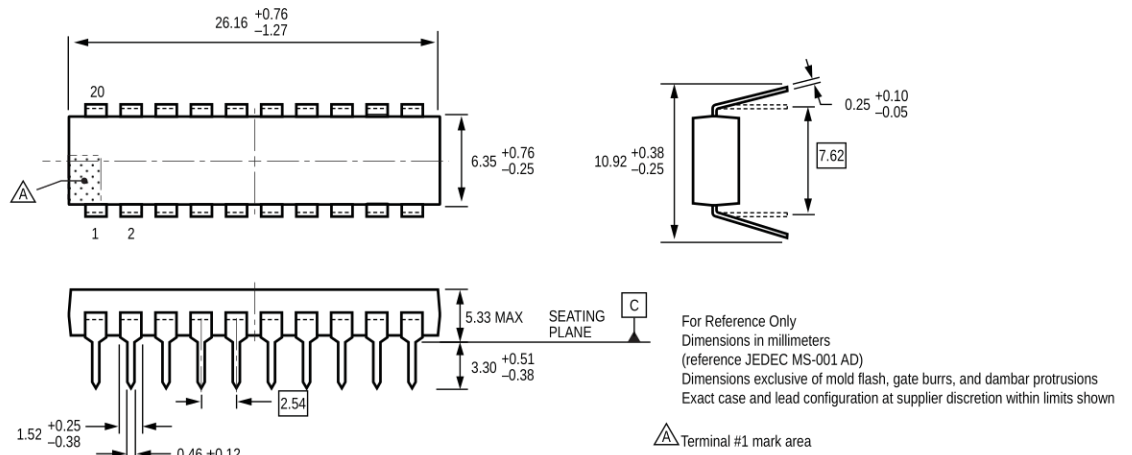

Package LW, 20-pin SOIC-W

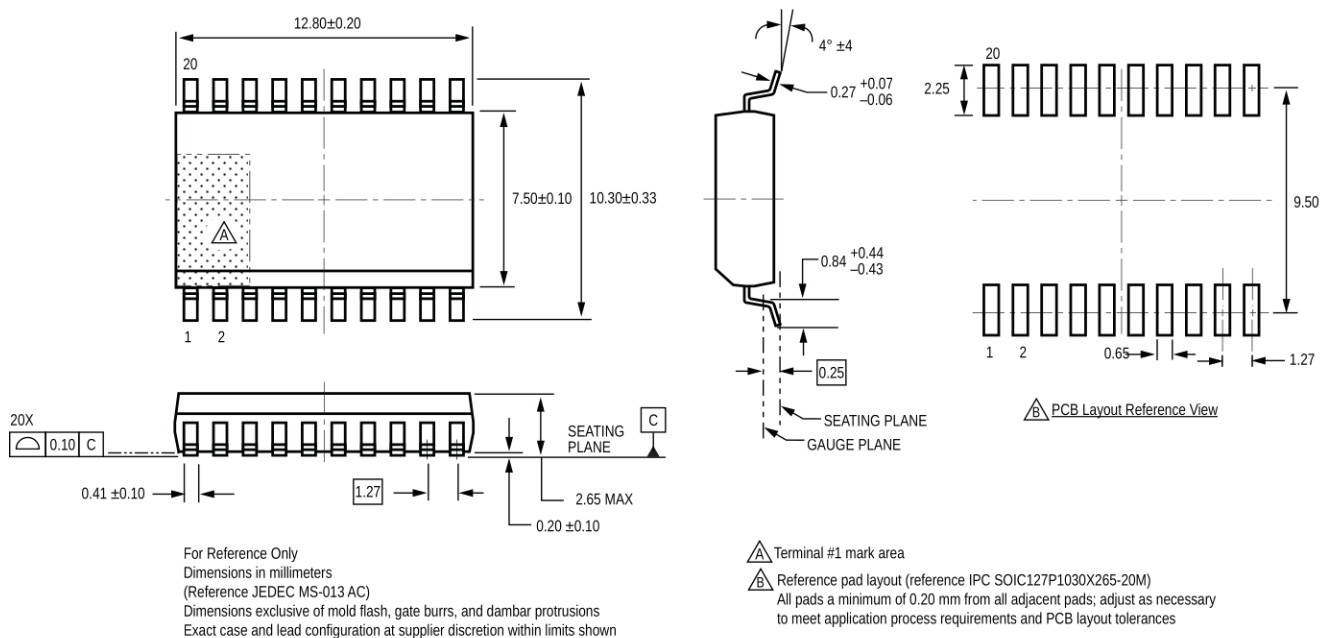

Copyright ©2006-2008, Allegro MicroSystems, Inc.

The products described herein are manufactured under one or more of the following U.S. patents: 5,045,920; 5,264,783; 5,442,283; 5,389,889; 5,581,179; 5,517,112; 5,619,137; 5,621,319; 5,650,719; 5,686,894; 5,694,038; 5,729,130; 5,917,320; and other patents pending.

Allegro MicroSystems, Inc. reserves the right to make, from time to time, such departures from the detail specifications as may be required to permit improvements in the performance, reliability, or manufacturability of its products. Before placing an order, the user is cautioned to verify that the information being relied upon is current.

Allegro's products are not to be used in life support devices or systems, if a failure of an Allegro product can reasonably be expected to cause the failure of that life support device or system, or to affect the safety or effectiveness of that device or system.

The information included herein is believed to be accurate and reliable. However, Allegro MicroSystems, Inc. assumes no responsibility for its use; nor for any infringement of patents or other rights of third parties which may result from its use.

For the latest version of this document, visit our website:

www.allegromicro.com

