



■ Typical Specifications



Items		Specifications
Rating		Each lead 0.5mA 5V DC Common lead 1mA 5V DC
Operating life	Without detent	Heavy: 15,000 cycles, Standard: 30,000 cycles
	With detent	30,000 cycles
Operating temperature range		EC12E: -10°C to +70°C EC12D: -40°C to +85°C

■ Product Line
Standard Type

Length of the shaft LM ₁ (mm)	Detent torque (mN·m)	Number of detent	Number of pulse	Operating direction	Minimum order unit (pcs.)		Product No.	Drawing No.
					Japan	Export		
15	Standard 3 to 20	12	12	Vertical	2,400	2,400	EC12E1220407	2
20							EC12E1220406	1
25							EC12E1220405	
8.5 (Through shaft)	Lightest (jog) 3±2	24	24		3,000	3,000	EC12E1220301	3
20							EC12E1240405	
25							EC12E1240406	
8.5 (Through shaft)	Standard 3 to 20	24	24		2,400	2,400	EC12E1240301	3
15							EC12E24204A2	2
17.5							EC12E24204A7	1
20	EC12E24204A8							
25	EC12E24204A9							
8.5 (Through shaft)	Lightest (jog) 3±2	24	24		3,000	3,000	EC12E2420301	3
20				EC12E24404A8			1	
25				EC12E24404A6				
8.5 (Through shaft)	Standard 10 max.	Without	24	2,400	2,400	EC12E2440301	3	
20						EC12E24104A6	1	
25						EC12E2430404		
20	Heavy 25±15	Without	24	2,400	2,400	EC12E2430401	1	
25								

With Bushing Type

Length of the shaft LM ₁ (mm)	Detent torque (mN·m)	Number of detent	Number of pulse	Operating direction	Minimum order unit (pcs.)		Product No.	Drawing No.
					Japan	Export		
25	Standard 3 to 20	12	12	Vertical	1,900	1,900	EC12E1220813	4
20		24	24				EC12E2420802	
25							EC12E2420801	
30	Heavy 25±15	Without	24				EC12E2420803	
20							EC12E2430804	
25							EC12E2430803	
30	Heavy 40±15			EC12E2460802				

Nuts and washers are not included. If required, please contact us.

Encoders

Metal
Shaft

Insulated
Shaft

Through
Shaft Type

Ring
Type

Product Line

With Switch Type

Length of the shaft LM ₁ (mm)	Detent torque (mN·m)	Number of detent	Number of pulse	Operating direction	Operating force of switch (N)	Travel of push-on switch (mm)	Minimum order unit (pcs.)		Product No.	Drawing No.
							Japan	Export		
17.5	5±3	30	15	Vertical	3	0.5	1,280	2,560	EC12D1524403	5
	10±5								EC12D1564402	
	5±3				EC12D1524406					
	10±5				EC12D1564404					

Notes

EC12D is suitable for automotive use.





Packing Specifications

Tray

Product No.	Number of packages (pcs.)		Export package measurements (mm)
	1 case /Japan	1 case /export packing	
EC12E □□□ 03	3,000	3,000	525×369×204
EC12E □□□ 04	2,400	2,400	
EC12E □□□ 08	1,900	1,900	
EC12D	1,280	2,560	540×360×290

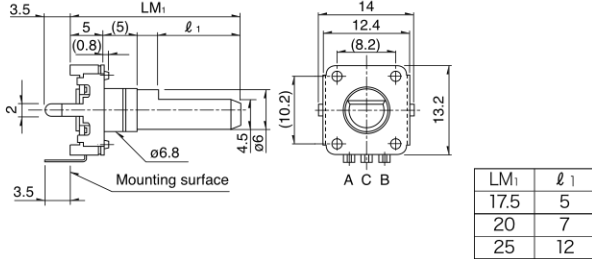
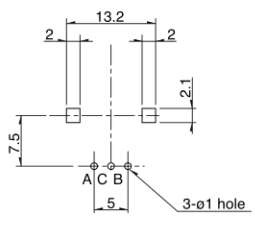
Dimensions

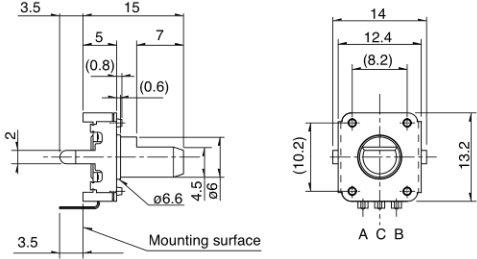
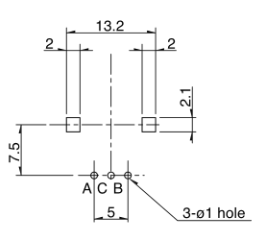

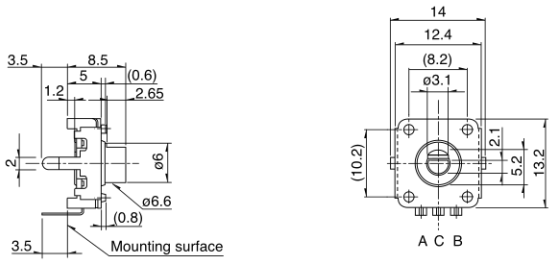
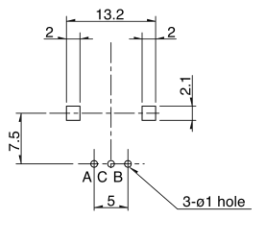
Unit:mm

No.	Photo	Style	PC board mounting hole dimensions (Viewed from mounting side)								
1		 <table border="1" data-bbox="981 1339 1101 1433"> <thead> <tr> <th>LM₁</th> <th>ℓ₁</th> </tr> </thead> <tbody> <tr> <td>17.5</td> <td>5</td> </tr> <tr> <td>20</td> <td>7</td> </tr> <tr> <td>25</td> <td>12</td> </tr> </tbody> </table>	LM ₁	ℓ ₁	17.5	5	20	7	25	12	
LM ₁	ℓ ₁										
17.5	5										
20	7										
25	12										
2											
3											

Refer to P.279 for product varieties.
 Refer to P.279 for switch specifications.
 Refer to P.299 for soldering conditions.

Dimensions

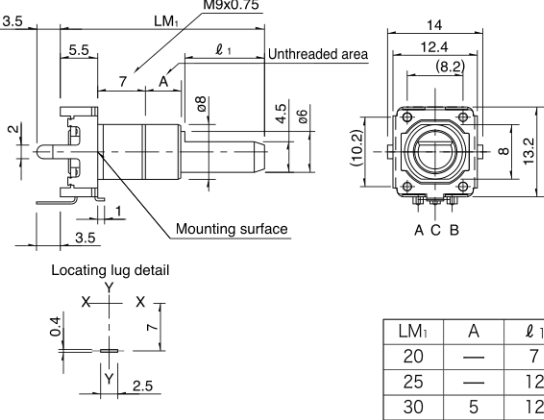
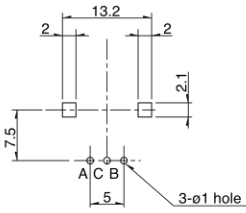
Unit:mm

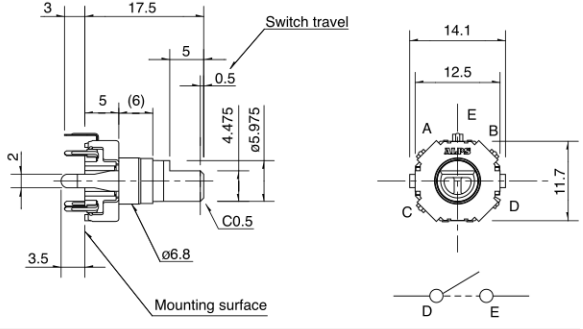
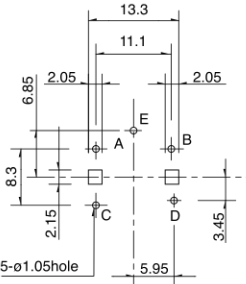
No.	Photo	Style	PC board mounting hole dimensions (Viewed from mounting side)												
4		 <table border="1" data-bbox="922 698 1104 801"> <thead> <tr> <th>LM₁</th> <th>A</th> <th>l₁</th> </tr> </thead> <tbody> <tr> <td>20</td> <td>—</td> <td>7</td> </tr> <tr> <td>25</td> <td>—</td> <td>12</td> </tr> <tr> <td>30</td> <td>5</td> <td>12</td> </tr> </tbody> </table>	LM ₁	A	l ₁	20	—	7	25	—	12	30	5	12	
LM ₁	A	l ₁													
20	—	7													
25	—	12													
30	5	12													
5	 <p>Car Use</p>														

Output Wave

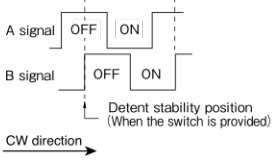
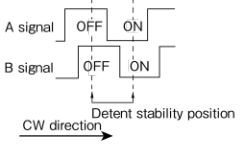
EC12E	EC12D
 <p>Detent stability position (When the switch is provided)</p> <p>‡Detent position cannot be specified for B signal.</p>	 <p>Detent stability position</p>

Sliding Noise

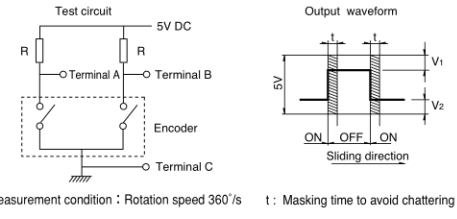
EC12E	EC12D
 <p>Measurement condition : Rotation speed 360°/s t : Masking time to avoid chattering</p>	<p>$V_1 = V_2 = 1.5V$ max. At $R = 10k \Omega$ Chattering : 3ms max. Bounce : 2ms max.</p> <p>$V_1 = V_2 = 2.5V$ max. At $R = 5k \Omega$ Chattering : 3ms max. Bounce : 2ms max.</p>

12mm Size Insulated Shaft Type / Product Varieties

■ Shaft Dimensions





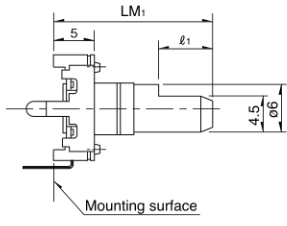
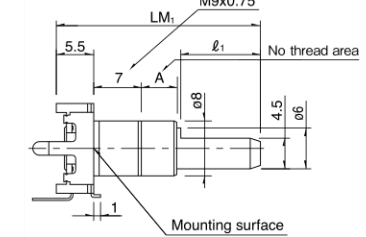



Flat Type

Unit:mm

<p>High collar type</p>		<p>Detailed dimensions</p> <table border="1"> <thead> <tr> <th></th> <th>LM₁</th> <th>l₁</th> </tr> </thead> <tbody> <tr> <td>※</td> <td>17.5</td> <td>5</td> </tr> <tr> <td></td> <td>20</td> <td>7</td> </tr> <tr> <td>※</td> <td>22.5</td> <td>7</td> </tr> <tr> <td></td> <td>25</td> <td>12</td> </tr> <tr> <td></td> <td>30</td> <td>12</td> </tr> </tbody> </table> <p>※ Not available for types without detents</p>		LM ₁	l ₁	※	17.5	5		20	7	※	22.5	7		25	12		30	12
	LM ₁	l ₁																		
※	17.5	5																		
	20	7																		
※	22.5	7																		
	25	12																		
	30	12																		
<p>With bushing type</p>		<p>Detailed dimensions</p> <table border="1"> <thead> <tr> <th>LM₁</th> <th>A</th> <th>l₁</th> </tr> </thead> <tbody> <tr> <td>20</td> <td>—</td> <td>7</td> </tr> <tr> <td>25</td> <td>—</td> <td>12</td> </tr> <tr> <td>30</td> <td>5</td> <td>12</td> </tr> <tr> <td>35</td> <td>5</td> <td>12</td> </tr> </tbody> </table> <p>Excluding the 12 detent type</p>	LM ₁	A	l ₁	20	—	7	25	—	12	30	5	12	35	5	12			
LM ₁	A	l ₁																		
20	—	7																		
25	—	12																		
30	5	12																		
35	5	12																		

12mm Size Insulated Shaft Type / Switch Specifications

Switch type	Momentary push switch	
Contact arrangement	Single pole and single throw (Push-on)	
Travel (mm)	0.5±0.3	
Operating force	3 ± ^{1.5} ₂ N, 6 ± ^{2.5} ₂ N	
Operating life	30,000 times	
Electrical performance	Rating	1mA 5V DC (10mA 5V DC max. ratings)
	Contact resistance	100mΩ max. for initial period, 200mΩ max. after operating life.
	Insulation resistance	100MΩ min. 250V DC
	Voltage proof	300V AC for 1 minute or 360V AC for 1 second

Type		Metal shaft	Insulated shaft		
		20mm size	12mm size		18mm size
Series		EC20A	EC12E	EC12D	EC18A
Photo					
Output		Incremental (Two phase A and B)			Absolute type
Shaft types		Single-shaft			
Operating direction		Vertical			
Number of pulse / Number of detent		18/18	12/12 24/24 24/without	15/30	12 positions 15 positions 16 positions
Features		—	—	With push-on switch	Water resisting performance (IPX7)
Dimensions (mm)	W	20.2	12.4	12.5	18.8
	D	19.2	13.2	11.7	18
	H	10	5		8.75
Operating temperature range		-30°C to +80°C	-10°C to +70°C	-40°C to +85°C	-20°C to +60°C
Operating life		30,000 cycles	15,000 cycles 30,000 cycles	30,000 cycles	
Automotive use		●	—	●	—
Life cycle (availability)					
Electrical performance	Rating	1mA 5V DC	0.5mA 5V DC	1mA 5V DC	1mA 10V DC
	Max./min. operating current (Resistive load)	—	5mA / 0.5mA	10mA / 1mA	—
	Insulation resistance	10MΩ min. 50V DC		100MΩ min. 250V DC	10MΩ min. 250V DC
	Voltage proof	50V AC for 1 minute or 60V AC for 2s	50V AC for 1 minute	300V AC for 1 minute or 360V AC for 1s	50V AC for 1 minute or 60V AC for 2s
Mechanical performance	Rotational torque (Without detent)	—	10mN·m max. 25±15mN·m 40±15mN·m	—	—
	Detent torque	40±20mN·m	3±2mN·m 3 to 20mN·m	5±3mN·m 10±5mN·m	60±20mN·m
	Push-pull strength	100N	80N	100N	Push 100N / Pull 50N
Shaft configuration		Flat	Flat, Through shaft	Flat	
Terminal type		Insertion			
Switch Specifications	Switch type	Push-on switch	—	Push-on switch	—
	Contact arrangement	Single pole and single throw (Push-on)	—	Single pole and single throw (Push-on)	—
	Travel (mm)	1.5±0.5	—	0.5±0.3	—
	Operating force (N)	4±2	—	3 ^{+1.5} ₋₁ 6 ^{+2.5} ₋₂	—
	Rating	0.1A 5V DC (0.1mA 5V DC min. ratings)	—	1mA 5V DC (10mA 5V DC max. ratings)	—
	Contact resistance	100mΩ max. for initial period; 200mΩ max. after operating life.	—	100mΩ max. for initial period; 200mΩ max. after operating life.	—
	Operating life	20,000 times	—	30,000 times	—
Page		273	276		280

Encoders Soldering Conditions 299

Encoders Cautions 300

Note

● Indicates applicability to all products in the series.

Reference for Manual Soldering

Series	Tip temperature	Soldering time	No. of solders
EC05E, EC09E, EC10E, EC111, EC11B, EC11E, EC11G, EC11K, EC11M, EC11N, EC12D, EC12E, EC18A, EC21A, EC28A, EC35A, EC35AH, EC40A, EC45A, EC50A, EC60B, EM11B, EC21C, EC28C, EC35CH	350°C max.	3s max.	1 time
EC11J	350±10°C	3 ⁺¹ ₀ s	2 times

Reference for Dip Soldering

Series	Preheating		Dip soldering		No. of solders
	Soldering surfacetemperature	Heating time	Soldering temperature	Soldering time	
EC09E, EC11B, EC111, EC11E, EC11G, EC11K, EC11M, EC11N, EC18A, EC21A, EC28A, EC35A, EC35AH, EC50A, EC60B	100°C max.	2 min. max.	260±5°C	5±1s	2 times max.
EM11B	100°C max.	1 min. max.	260°C max.	3s max.	2 times max.
EC10E, EC12D, EC12E	100°C max.	1 min. max.	260±5°C	3±1s	2 times max.
EC40A	110°C max.	1 min. max.	260°C max.	10s max.	1 time
EC45A	100°C max.	2 min. max.	260°C max.	5s max.	2 times max.

Example of Reflow Soldering Condition

Temperature profile

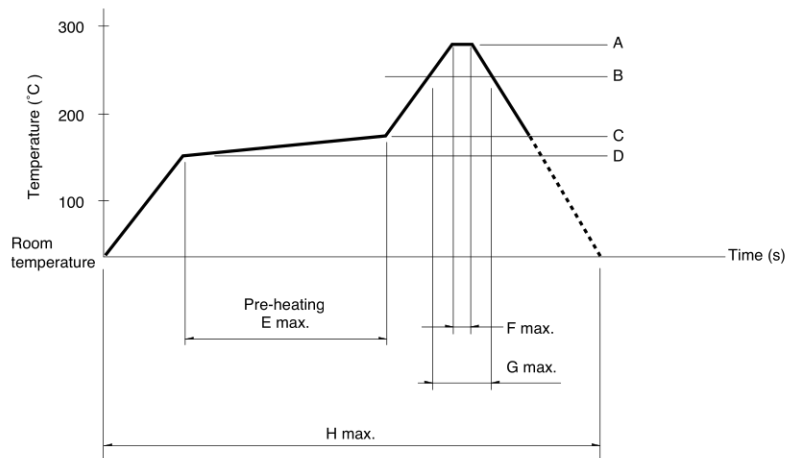

Series	A	B	C	D	E	F	G	H	No. of reflows
EC11J	260°C	230°C	180°C	150°C	2 min. max.	3s	40s	4 min. max.	2 times max.
EC05E	250°C min.	230°C min.	180°C	150°C	60s to 120s	—	30s to 40s	—	2 times max.
EC21C	230°C to 245°C	220°C	200°C	150°C	60s to 120s	—	25s to 60s	300s max.	1 time max.
EC28C, EC35CH	260°C	230°C	180°C	150°C	2 min. min.	3s	40s	230s max.	1 time max.

Notes

1. When using an infrared reflow oven, solder may sometimes not be applied. Be sure to use a hot air reflow oven or a type that uses infrared rays in combination with hot air.
2. The temperatures given above are the maximum temperatures at the terminals of the encoder when employing a hot air reflow method. The temperature of the PC board and the surface temperature of the encoder may vary greatly depending on the PC board material, its size and thickness. Ensure that the surface temperature of the encoder does not rise to 250°C or greater.
3. Conditions vary to some extent depending on the type of reflow bath used. Be sure to give due consideration to this prior to use.

Mouser Electronics

Authorized Distributor

Click to View Pricing, Inventory, Delivery & Lifecycle Information:

ALPS:

[EC12E1220301](#) [EC12E1240405](#) [EC12E1240406](#) [EC12E1240301](#) [EC12E24404A8](#) [EC12E24404A6](#)
[EC12E2440301](#) [EC12E2430404](#) [EC12E2430401](#) [EC12E2430804](#) [EC12E2430803](#) [EC12E24204A7](#) [EC12E24104A6](#)
[EC12E1220813](#) [EC12E2420803](#) [EC12E2460802](#) [EC12D1564402](#) [EC12D1524403](#) [EC12E2420801HARD](#)
[EC12E2420301](#) [EC12E1220405](#) [EC12E1220407](#) [EC12E1220406](#) [EC12D1564404](#) [EC12E24204A8](#) [EC12E24204A9](#)
[EC12D1524406](#) [EC12E2420802](#) [EC12E24204A2](#) [EC12E2420801](#)