

# EC20A RK203

## 20mm Size Metal Shaft Type

Heavy torque and comfortable operation feel for encoder and potentiometer applications



### Typical Specifications

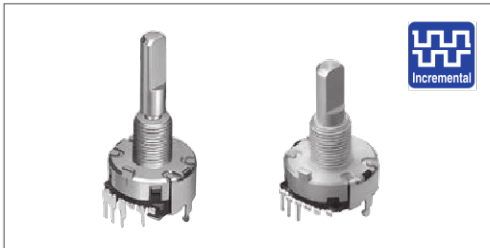

Items	Specifications	
	Encoder	Potentiometer
Rating	1mA 5V DC	0.05W
Operating life	30,000 cycles	
Operating temperature range	-30°C to +80°C	-40°C to +85°C

### Product Line

#### Encoders

Shaft configuration	Length of the shaft (mm)	Detent torque (mN·m)	Number of detent	Number of pulse	Operating direction	Push-on switch	Travel of push-on switch (mm)	Minimum order unit (pcs.)		Product No.	Drawing No.
								Japan	Export		
Flat	30	40±20	18	18	Vertical	With	1.5	400	800	<b>EC20A1824401</b>	1
						Without	—			<b>EC20A1820401</b>	2

#### Potentiometer

Shaft configuration	Length of the shaft (mm)	Detent torque (mN·m)	Number of detent	Rotational angle	Mounting direction	Number of resistor elements	Total resistance (kΩ)	Resistance taper	Minimum order unit (pcs.)		Product No.	Drawing No.
									Japan	Export		
Flat	30	40±20	17	220°	Vertical	Single-unit	10	1B	800	800	<b>RK203111000V</b>	3

### Notes

1. Only the encoder type can be supplied with a push-on switch.
2. Shaft design and other features are customizable.

### Packing Specifications

#### Tray



Number of packages (pcs.)		Export package measurements (mm)
1 case /Japan	1 case /export packing	
400	800	374×508×272

### Dimensions

No.	Photo	Style	PC board mounting hole dimensions (Viewed from mounting side)
1	<p><b>EC20A with push-on switch (travel 1.5mm) Encoder type</b></p>		

Refer to P.284 for attached parts.  
Refer to P.284 for switches.  
Refer to P.307 for soldering conditions.

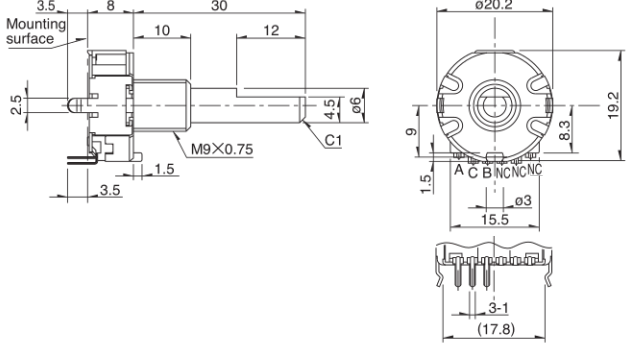
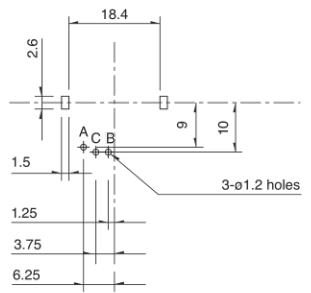
■ Dimensions

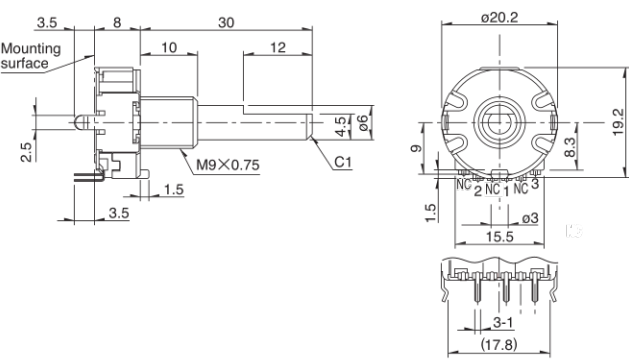
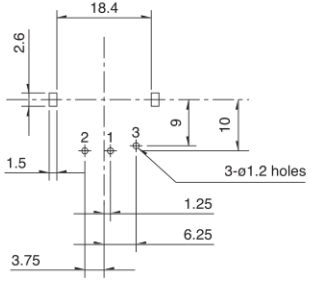
No.	Photo	Style	PC board mounting hole dimensions (View from mounting side)
2	 <p><b>EC20A without switch type Encoder type</b></p>	 <p>3.5 8 30 10 12 2.5 1.5 3.5 4.5 0.6 M9×0.75 C1 ø20.2 9 1.5 15.5 19.2 8.3 15.5 3-1 (17.8) A C B NC NC NC</p>	 <p>18.4 2.6 1.5 9 10 3-ø1.2 holes 1.25 3.75 6.25</p>
3	 <p><b>RK203 without switch type Potentiometer type</b></p>	 <p>3.5 8 30 10 12 2.5 1.5 3.5 4.5 0.6 M9×0.75 C1 ø20.2 9 1.5 15.5 19.2 8.3 15.5 3-1 (17.8) NC 2 NC 1 NC 3</p>	 <p>18.4 2.6 1.5 9 10 3-ø1.2 holes 1.25 3.75 6.25</p>

■ Output Wave (EC20A)

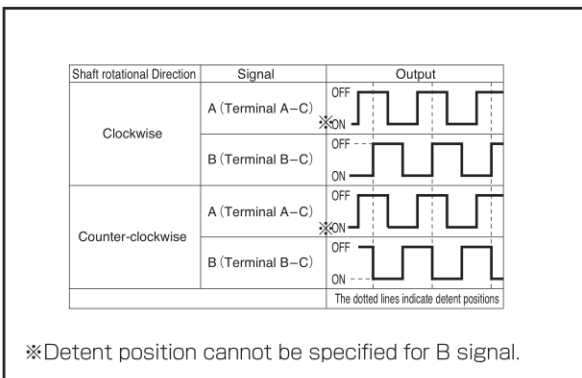

■ Output Wave (EC20A)

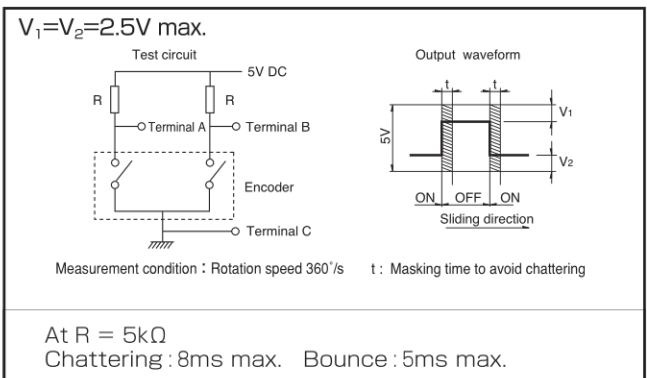

Encoders  
Metal Shaft  
Insulated Shaft  
Hollow Shaft  
Ring Type

**Circuit Diagram (RK203)**

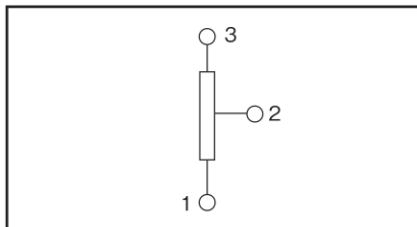













**20mm Size Metal Shaft Type / Attached Parts**

The following parts are included with the product.

		Unit:mm	
Nut		Washer	

**20mm Size Metal Shaft Type / Switch Specifications**

Switch type	Momentary push switch	
Contact arrangement	Single pole and single throw (Push-on)	
Travel (mm)	1.5±0.5	
Operating force	4±2N	
Operating life	20,000 times	
Electrical performance	Rating	0.5A 16V DC (1mA 16V DC min. ratings)
	Contact resistance	100mΩ max. for initial period, 200mΩ max. after operating life.
	Insulation resistance	100MΩ min. 250V DC
	Voltage proof	300V AC for 1 minute or 360V AC for 2s

Type		Metal shaft											
		11 mm size					20mm size						
Series		EC111		EC11K		EC11J		EM11B	EC20A/RK203		EM20B		
Photo													
Output		Self-return switch			Incremental (Two phase A and B)								
Shaft types		Single-shaft											
Operating direction		Vertical											
Number of pulse / Number of detent		—		9/18 15/30			16/16		18/18		40/40		
Features		—		—		Surface Mount type		Magnetic type	—		Magnetic type		
Dimensions (mm)		W		11.7					10.8	20.2	20		
		D		13		12		14.2		11	19.2	22.25	
		H		5		4.5			7.5	10	13		
Operating temperature range		-40°C to +85°C						-30°C to +85°C	-30°C to +80°C	-10°C to +70°C			
Operating life		15,000 cycles		100,000 cycles			1,000,000 cycles		30,000 cycles	500,000 cycles			
Automotive use		●		●		●		●	●	—			
Life cycle (availability)													
Electrical performance		Rating		10mA 5V DC					10mA 5V±5% DC	1mA 5V DC	10mA 5V±5% DC		
		Max./min. operating current (Resistive load)		10mA / 1mA					15mA / —	—	15mA / —		
		Insulation resistance		100MΩ min. 250V DC						100MΩ min. 100V DC	10MΩ min. 50V DC	100MΩ min. 250V DC	
		Voltage proof		300V AC for 1 minute or 360V AC for 2s		300V AC for 1 minute or 360V AC for 1s			250V AC for 1 minute or 300V AC for 2s	50V AC for 1 minute or 60V AC for 2s	300V AC for 1 minute or 360V AC for 2s		
Mechanical performance		Rotational torque (Without detent)		3 to 30mN·m		—		—	—	7mN·m max.			
		Detent torque		—		12±5mN·m		12±5mN·m (initial) 12±4mN·m (After reflow)	10±5mN·m	40±20mN·m	8±5mN·m		
		Push-pull strength		100N									
Shaft configuration		Flat, Slotted, Serrated						Flat					
Terminal type		Insertion				Reflow			Insertion				
Switch Specifications		Switch type		Push-on switch									
		Contact arrangement		Single pole and single throw (Push-on)									
		Travel (mm)		0.5±0.3	1.5±0.5	0.5±0.3	1.5±0.5	0.5±0.3	1.5±0.5	0.5 ± <sub>0.2</sub> <sup>0.3</sup>	1.5±0.5	0.5 ± <sub>0.3</sub> <sup>0.4</sup>	
		Operating force (N)		6 ± <sub>2</sub> <sup>5</sup>	4±2	5±2	4±2	5±2	4±2	5.5±3	4±2	6±3	
		Rating		0.1A 5V DC (500μA 5V DC min. ratings)		0.1A 5V DC (0.1mA 5V DC min. ratings)			5mA 5V DC (50mA 12V DC max. ratings)	0.5A 16V DC (1mA 16V DC min. ratings)	3A 16V DC (10mA 16V DC min. ratings)		
		Contact resistance		100mΩ max. for initial period, 200mΩ max. after operating life.						500mΩ max. for initial period, 5mΩ max. after operating life.	100mΩ max. for initial period, 200mΩ max. after operating life.		
		Operating life		20,000 times	1,000,000 times	100,000 times	1,000,000 times	100,000 times	1,000,000 times	20,000 times	25,000 times		
Page		269						280	282	285			

Encoders Soldering Conditions	307
Encoders Cautions	308

#### Note

- Indicates applicability to all products in the series.

## Reference for Manual Soldering

Series	Tip temperature	Soldering time	No. of solders
EC05E, EC09E, EC10E, EC111, EC11B, EC11E, EC11G, EC11K, EC12D, EC12E, EC18A, EC21A, EC28A, EC35A, EC35AH, EC35B, EC40A, EC45A, EC50A, EC60B, EM11B, EM20B, EC21C	350°C max.	3s max.	1 time
EC11J	350±10°C	3 <sup>+1</sup> <sub>0</sub> s	2 time

## Reference for Dip Soldering

Series	Preheating		Dip soldering		No. of solders
	Soldering surfacetemperature	Heating time	Soldering temperature	Soldering time	
EC09E, EC11B, EC111, EC11E, EC11G, EC11K, EC18A, EC21A, EC28A, EC35A, EC35AH, EC35B, EC50A, EC60B	100°C max.	2 min. max.	260±5°C	5±1s	2 time max.
EC10E, EC12D, EC12E, EM11B	100°C max.	1 min. max.	260±5°C	3±1s	2 time max.
EC40A	110°C max.	1 min. max.	260°C max.	10s max.	1 time
EC45A	100°C max.	2 min. max.	260°C max.	5s max.	2 time max.
EM20B	80°C max.	1 min. max.	260°C max.	3s max.	2 time max.

## Example of Reflow Soldering Condition

Temperature profile

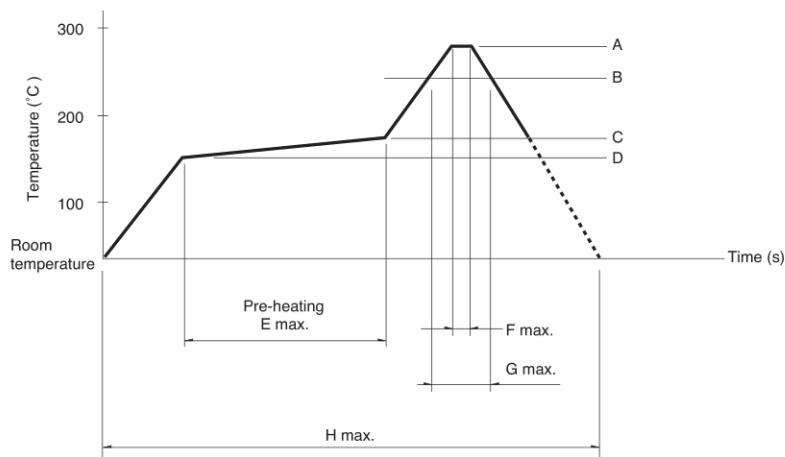

Series	A	B	C	D	E	F	G	H	No. of reflows
EC11J	260°C	230°C	180°C	150°C	2 min. max.	3s	40s	4 min. max.	2 time max.
EC05E	250°C min.	230°C min.	180°C	150°C	60s to 120s	—	30s to 40s	—	2 time max.
EC21C	230°C to 245°C	220°C	200°C	150°C	60s to 120s	—	25s to 60s	300 max.	1 time max.

### 注記

- When using an infrared reflow oven, solder may sometimes not be applied. Be sure to use a hot air reflow oven or a type that uses infrared rays in combination with hot air.
- The temperatures given above are the maximum temperatures at the terminals of the encoder when employing a hot air reflow method. The temperature of the PC board and the surface temperature of the encoder may vary greatly depending on the PC board material, its size and thickness. Ensure that the surface temperature of the encoder does not rise to 250°C or greater.
- Conditions vary to some extent depending on the type of reflow bath used. Be sure to give due consideration to this prior to use.