

Versatile DC/DC Converter

FEATURES

- 3V to 30V Input Voltage Operation.
- Internal 2A Peak Current Switch.
- 1.5A Continuous Output Current.
- Bootstrapped Driver.
- High Side Current Sense Capability.
- High Efficiency (up to 90%).
- Internal $\pm 2\%$ Reference.
- Low Quiescent Current at 1.6mA.
- Frequency Operation from 100Hz to 100KHz.

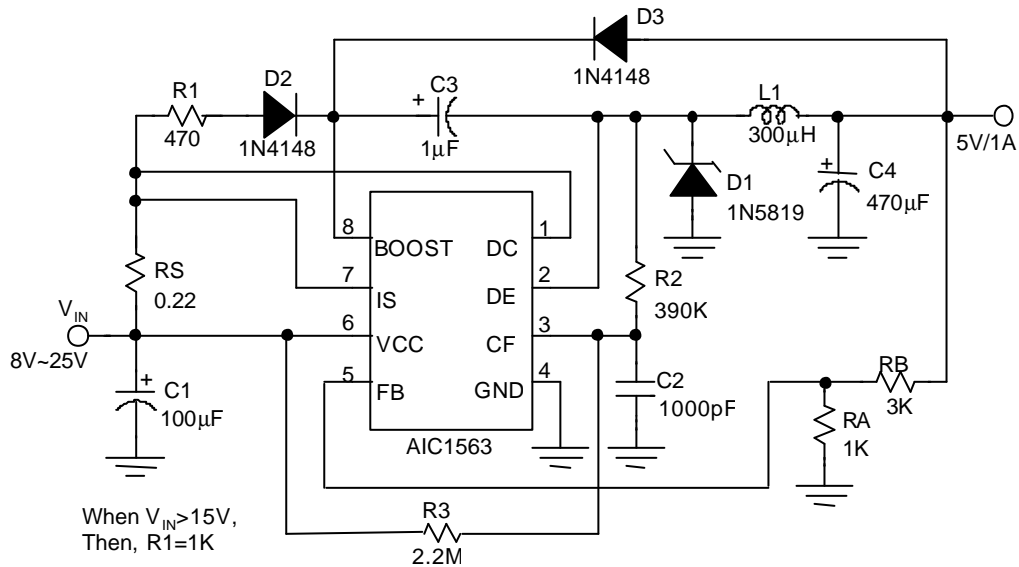
APPLICATIONS

- Constant Current Source for Battery Chargers.
- Saver for Cellular phones.
- Step-Down DC-DC Converter Module.

DESCRIPTION

The AIC1563 is a monolithic control circuit containing the primary functions required for DC to DC converters and highside-sensed constant current source. The device consists of an internal temperature compensated reference, comparator, controlled duty cycle oscillator with an active current sense circuit, bootstrapped driver, and high current output switch. This device is specifically designed to construct a constant current source for battery chargers with a minimum number of external components. Bootstrapped driver can drive the NPN output switch to saturation for higher efficiency and less heat dissipation. The AIC1563 can deliver 1.5A continuous current without requiring a heat sink.

TYPICAL APPLICATION CIRCUIT



Line Regulation	$V_{IN} = 10V \sim 20V @ I_O = 1A$	40mV
Load Regulation	$V_{IN} = 15V, @ I_O = 100mA \sim 1A$	20mV
Short Circuit Current	$V_{IN} = 15V, @ R_L = 0.1\Omega$	1.3A

Step-Down Converter

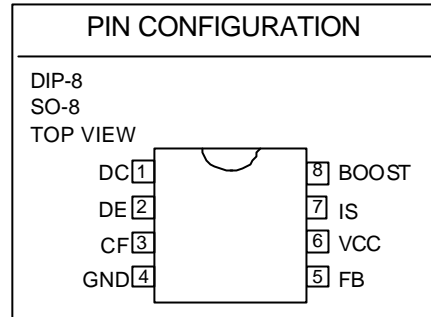
ORDERING INFORMATION

AIC1563-CXXX

PACKING TYPE
 TR: TAPE & REEL
 TB: TUBE

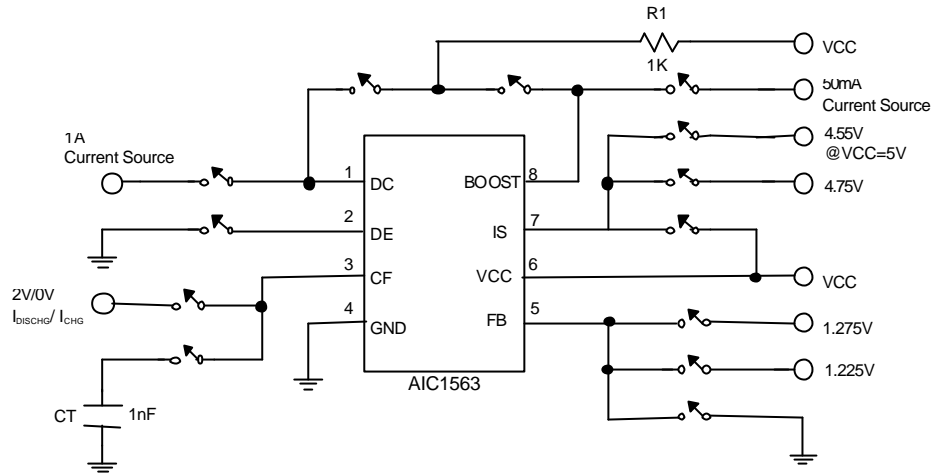
PACKAGING TYPE
 N: PLASTIC DIP
 S: SMALL OUTLINE

Example: AIC1563CSTR
 → in SO-8 Package & Taping & Reel
 Packing Type
 (CN is not available in TR packing)



ABSOLUTE MAXIMUM RATINGS

Supply Voltage.....	30V
Comparator Input Voltage Range	-0.3V~30V
Switch Collector Voltage.....	30V
Switch Emitter Voltage.....	30V
Switch Collector to Emitter Voltage	30V
Driver Collector Voltage.....	30V
Switch Current	2A
Power Dissipation and Thermal Characteristics	
DIP Package	
Ta= 25°C.....	1.0W
Thermal Resistance	100°C/W
SO Package	
Ta= 25°C.....	625mW
Thermal Resistance	160°C/W
Operating Junction Temperature	125°C
Operating Ambient Temperature Range	0~70°C
Storage Temperature Range	- 65°C ~ 150°C

TEST CIRCUIT

ELECTRICAL CHARACTERISTICS ($V_{CC}=5V$, $T_A=25^\circ C$, unless otherwise specified.)

PARAMETER	TEST CONDITIONS	SYMBOL	MIN.	TYP.	MAX.	UNIT
Oscillator						
Charging Current	$5.0V \leq V_{CC} \leq 30V$	I_{CHG}	10	25	40	μA
Discharge Current	$5.0V \leq V_{CC} \leq 30V$	I_{DISCHG}	100	150	200	μA
Voltage Swing	PIN 3	V_{OSC}		0.6		V
Discharge to Charge Current Ratio	$V_{IS} = V_{CC}$	I_{DISCHG} / I_{CHG}		6.0		
Current Limit Sense Voltage	$I_{CHG} = I_{DISCHG}$	$V_{CC} - V_{IS}$	250	300	350	mV
Output Switch						
Saturation Voltage, Emitter Follower Connection	$I_{DE} = 1.0A$; $V_{BOOST} = V_{DC} = V_{CC}$	$V_{CE(SAT)}$		1.5	1.8	V
Saturation Voltage	$I_{DC} = 1.0A$; $I_{BOOST} = 50mA$, (Forced $\beta \approx 20$)	$V_{CE(SAT)}$		0.4	0.7	V
DC Current Gain	$I_{SC} = 1.0A$; $V_{CE} = 5.0V$	h_{FE}	35	120		
Collector Off-State Current	$V_{CE} = 30V$	$I_{C(OFF)}$		10		nA

ELECTRICAL CHARACTERISTICS ($V_{CC}=5V$, $T_A=25^\circ C$, unless otherwise specified.)

PARAMETER	TEST CONDITIONS	SYMBOL	MIN.	TYP.	MAX.	UNIT
Comparactor						
Threshold Voltage	$T_A=25^\circ C$	V_{FB}	1.225	1.25	1.275	V
	$0^\circ C \leq T_A \leq 70^\circ C$		1.21		1.29	V
Threshold Voltage Line Regulation	$3.0V \leq V_{CC} \leq 30V$	REG_{LINE}		0.1	0.3	mV/V
Input Bias Current	$V_{IN}=0V$	I_{IB}		0.4	1	μA
Supply Current	$V_{IS} = V_{CC}$, pin 5 > V_{FB} $5.0V \leq V_{CC} \leq 30V$ $C_T=1nF$ PIN 2=GND Remaining pins open	I_{CC}		1.6	3	mA

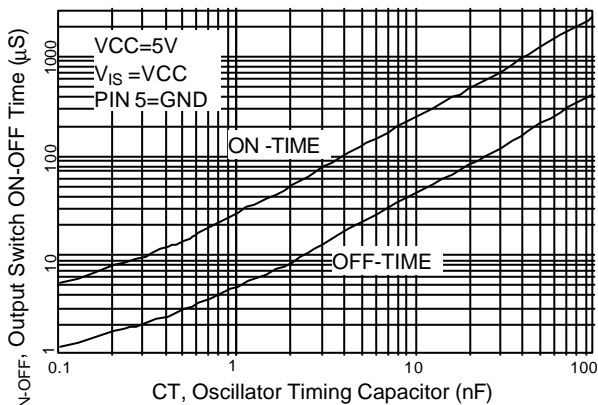
TYPICAL PERFORMANCE CHARACTERISTICS


Fig. 1 Output Switch ON-OFF Time vs. Oscillator Timing Capacitor

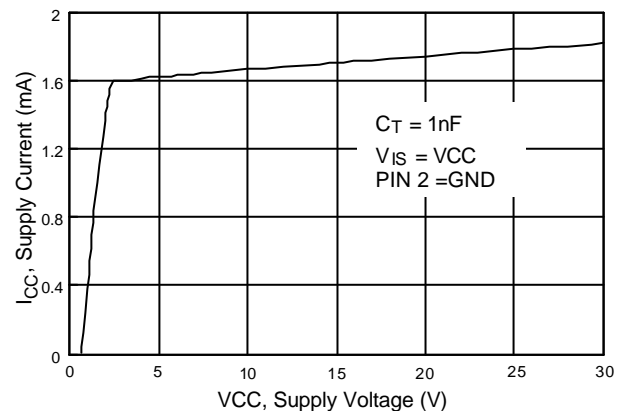


Fig. 2 Standby Supply Current vs. Supply Voltage

TYPICAL PERFORMANCE CHARACTERISTICS (Continued)

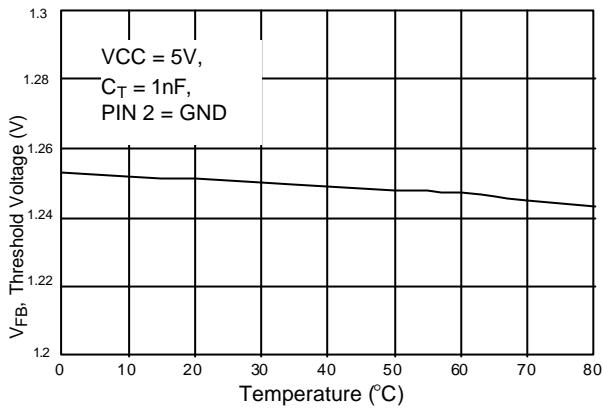


Fig. 3 V_{FB} Threshold Voltage vs. Temperature

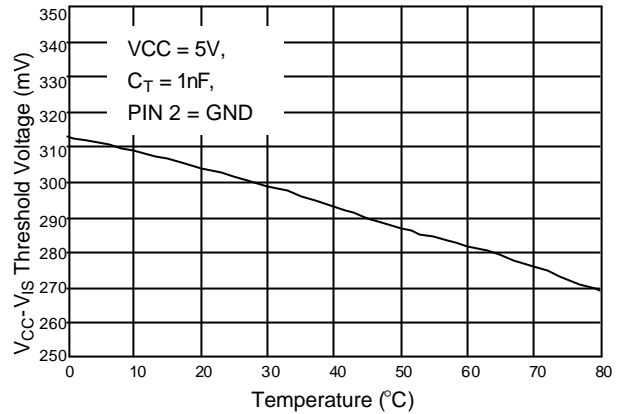


Fig. 4 I_S Threshold Voltage vs. Temperature

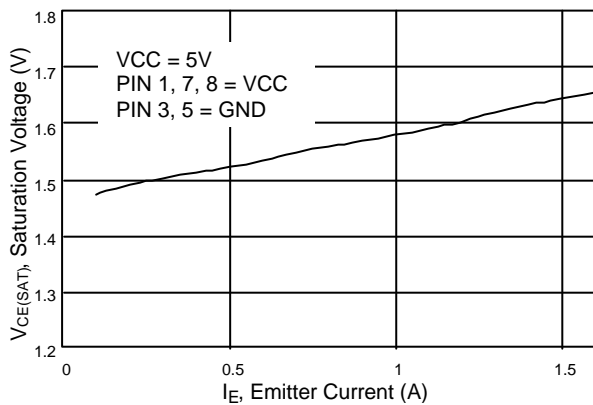


Fig. 5 Emmitter Follower Configuration Output Switch Saturation Voltage vs. Emmitter Current

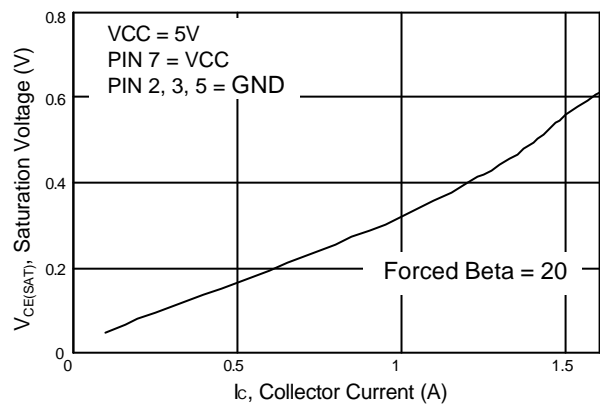
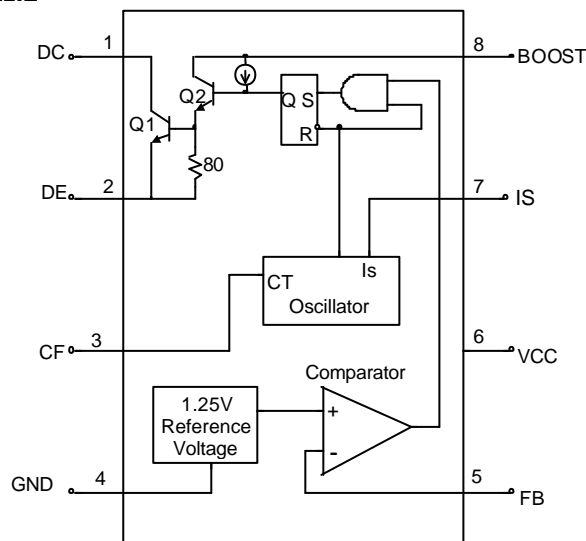


Fig. 6 Common Emmitter Configuration Output Switch Saturation Voltage vs. Collector Current

BLOCK DIAGRAM



■ PIN DESCRIPTIONS

- PIN 1: DC - The switch collector is 2A.
 PIN 2: DE - Darlington switch emitter.
 PIN 3: CF - Oscillator timing capacitor.
 PIN 4: GND - Power ground.
 PIN 5: FB - Feedback comparator inverting input.
 PIN 6: VCC - Power supply input.
 PIN 7: IS - Highside current sense input.
 VCC - $V_{IS}=300mV$.
 PIN 8: BOOST-Bootstrapped driver collector.

■ APPLICATION INFORMATIONS

● DESIGN FORMULA TABLE

CALCULATION	STEP-DOWN	STEP-UP
$\frac{t_{ON}}{t_{OFF}}$	$\frac{V_{OUT} + V_F}{V_{IN(MIN)} - V_{SAT} - V_{OUT}}$	$\frac{V_{OUT} + V_F - V_{IN(MIN)}}{V_{IN(MIN)} - V_{SAT}}$
$(t_{ON} + t_{OFF})_{MAX}$	$\frac{1}{F_{MIN}}$	$\frac{1}{F_{MIN}}$
C_T	$4 \times 10^{-5} t_{ON}$	$4 \times 10^{-5} t_{ON}$
$I_{C(SWITCH)}$	$2I_{OUT(MAX)}$	$2I_{OUT(MAX)} \left(\frac{t_{ON} + t_{OFF}}{t_{OFF}} \right)$
RS	$0.3/I_{C(SWITCH)}$	$0.3/ I_{C(SWITCH)}$
L(MIN)	$\left(\frac{V_{IN(MIN)} - V_{SAT} - V_{OUT}}{I_{C(SWITCH)}} \right) t_{ON(MAX)}$	$\left(\frac{V_{IN(MIN)} - V_{SAT}}{I_{C(SWITCH)}} \right) t_{ON(MAX)}$
Co	$\frac{I_{C(SWITCH)} (t_{ON} + t_{OFF})}{8V_{RIPPLE(P-P)}}$	$\frac{I_{OUT} t_{ON}}{V_{RIPPLE(P-P)}}$

V_{SAT} = Saturation voltage of the output switch.
 V_F = Forward voltage of the ringback rectifier

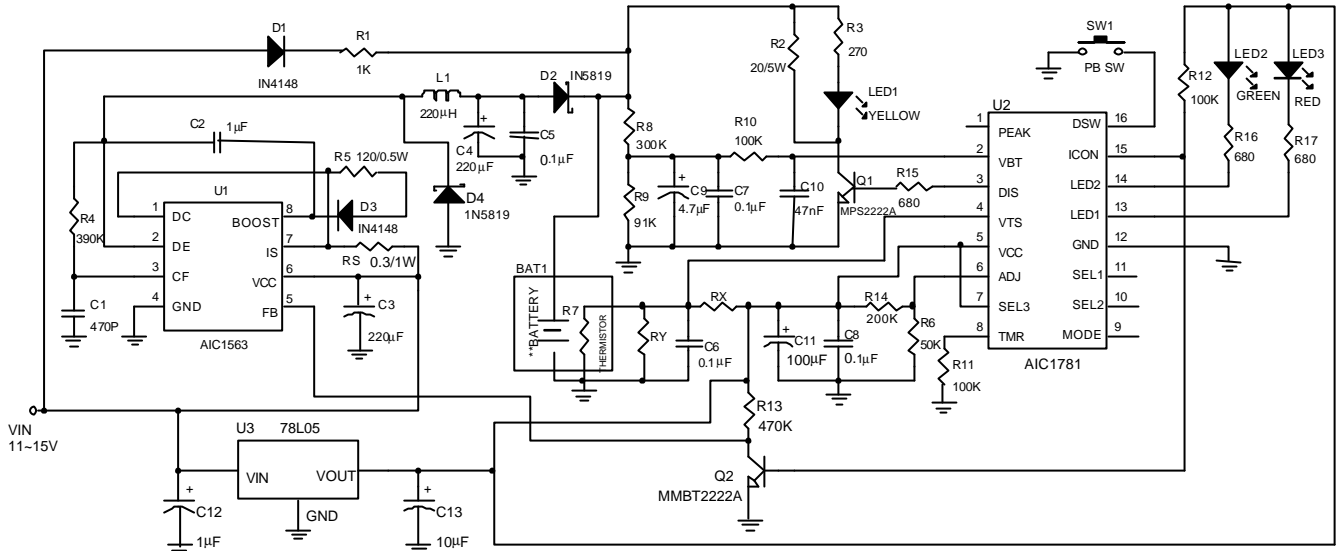
The following power supply characteristics must be chosen:

- V_{IN} - Nominal input voltage.
 V_{OUT} - Desired output voltage,
 $V_{OUT} = 1.25 (1 + RB/RA)$
 I_{OUT} - Desired output current.

F_{MIN} - Minimum desired switching frequency at selected values for V_{IN} and I_{OUT} .

$V_{RIPPLE(P-P)}$ -Desired peak-to-peak output ripple voltage. In practice, the calculated value will need to be increased due to the capacitor equivalent series resistance and board layout. The ripple voltage should be kept to a low value since it will directly affect the line and load regulation.

APPLICATION EXAMPLES



**3~5 NiMH/NiCd cells.
 Note: Charge Current=0.3/RS Ampere
 Safety Timer: 80min

Fig. 1 Battery Charge Circuit for Fluctuating Charging Current Applications

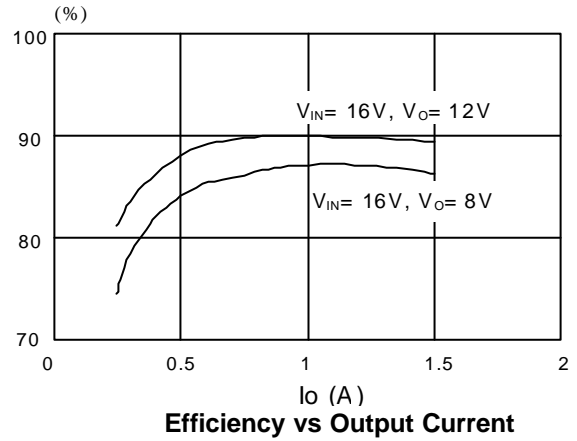
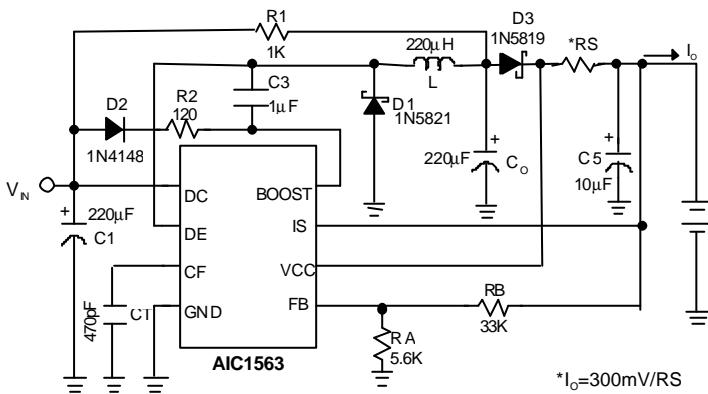


Fig. 2 Battery Charge Circuit

APPLICATION EXAMPLES (Continued)

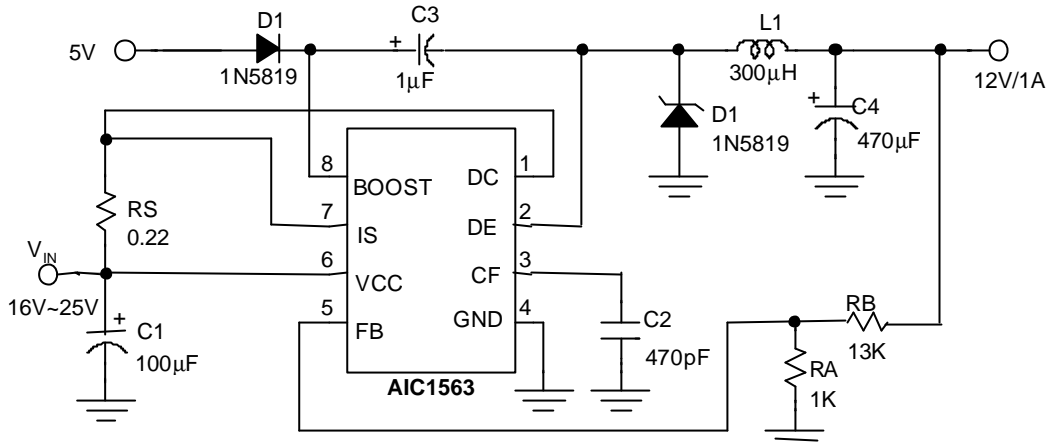
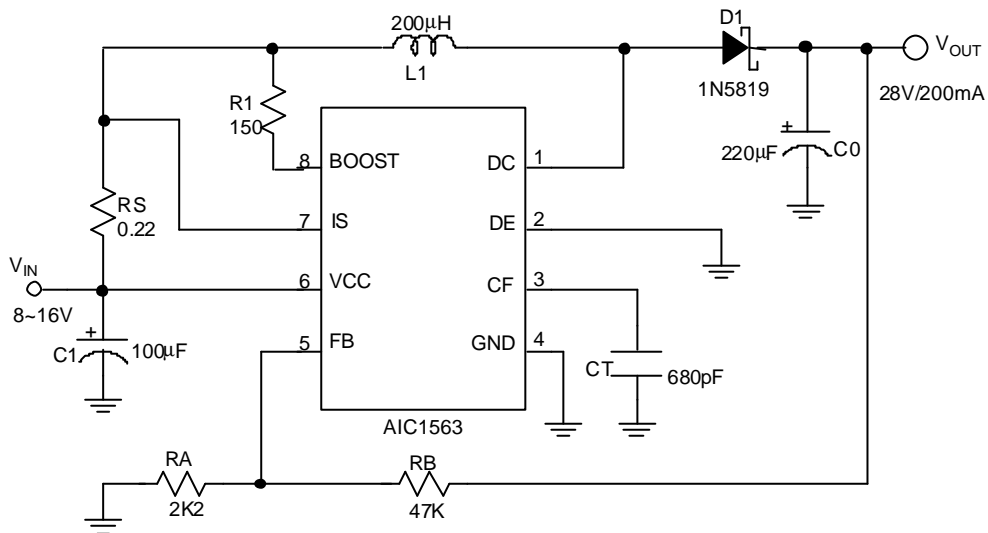


Fig. 3 Step-Down Converter with External 5V Bootstrap



Line Regulation	$V_{IN} = 8V \sim 16V @ I_O = 200mA$	100mV
Load Regulation	$V_{IN} = 12V, @ I_O = 80mA \sim 200mA$	40mV

Fig. 4 Step-Up Converter

APPLICATION EXAMPLES (Continued)

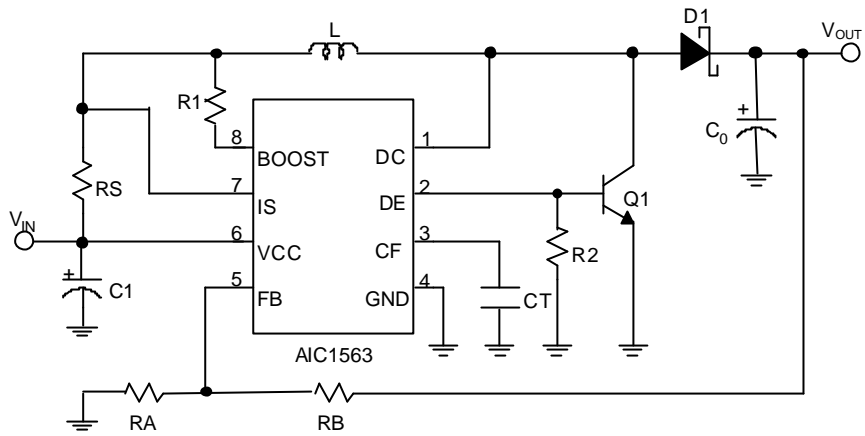
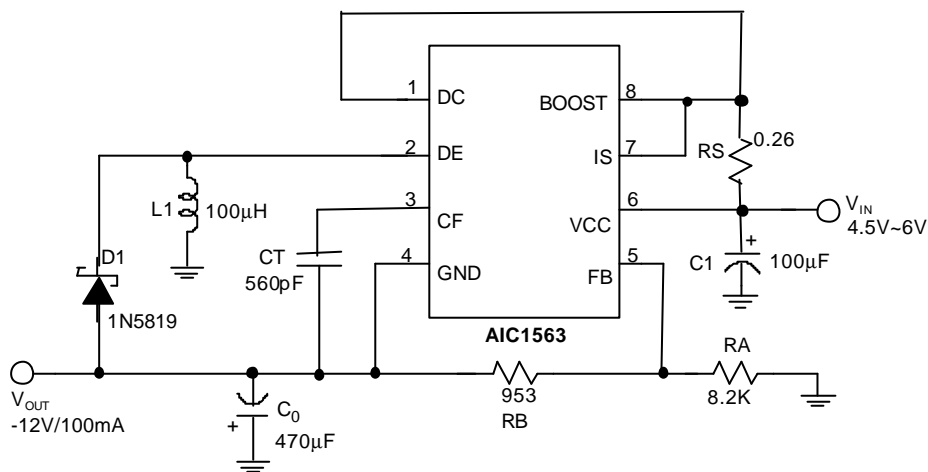


Fig. 5 Step-Up Converter with External NPN Switch

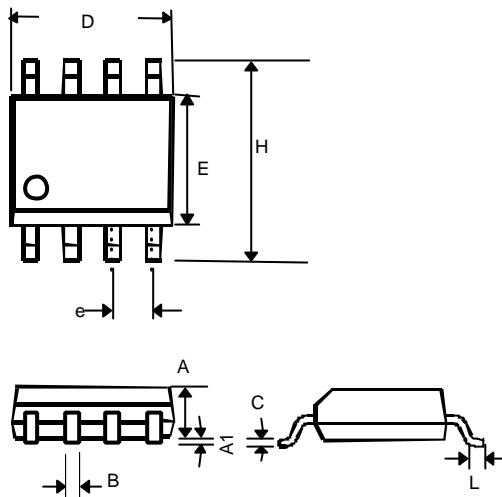


Line Regulation	$V_{IN} = 4.5V \sim 6V @ I_o = 100mA$	20mV
Load Regulation	$V_{IN} = 5V, @ I_o = 10mA \sim 100mA$	100mV

Fig. 6 Inverting Converter

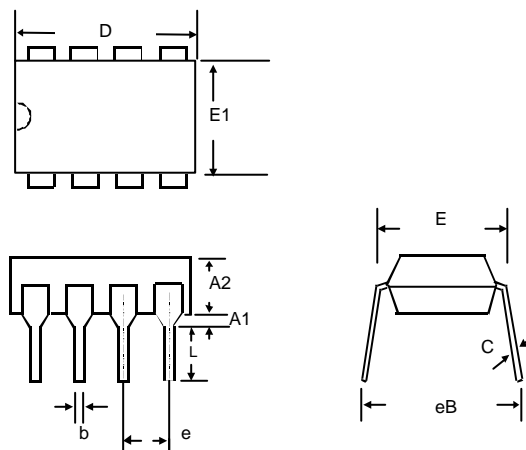
PHYSICAL DIMENSIONS

● **8 LEAD PLASTIC SO (unit: mm)**



SYMBOL	MIN	MAX
A	1.35	1.75
A1	0.10	0.25
B	0.33	0.51
C	0.19	0.25
D	4.80	5.00
E	3.80	4.00
e	1.27(TYP)	
H	5.80	6.20
L	0.40	1.27

● **8 LEAD PLASTIC DIP (unit: mm)**



SYMBOL	MIN	MAX
A1	0.381	—
A2	2.92	4.96
b	0.35	0.56
C	0.20	0.36
D	9.01	10.16
E	7.62	8.26
E1	6.09	7.12
e	2.54 (TYP)	
eB	—	10.92
L	2.92	3.81