

## FEATURES

- Operates with 3.3 V supply
- EIA RS-422 and RS-485 compliant over full CM range
- 19 k $\Omega$  input impedance
- Up to 50 transceivers on bus
- 20 Mbps data rate
- Short-circuit protection
- Specified over full temperature range
- Thermal shutdown
- Interoperable with 5 V logic
- 840  $\mu$ A supply current
- 2 nA shutdown current
- Available in PDIP, SOIC, and TSSOP
- Meets IEC1000-4-4 (>1 kV)
- 8 ns skew
- Upgrade for MAX3491, SN75ALS180

## APPLICATIONS

- Telecommunications
- DTE–DCE interface
- Packet switching
- Local area networks
- Data concentration
- Data multiplexers
- Integrated services digital network (ISDN)
- AppleTalk
- Industrial controls

## GENERAL DESCRIPTION

The **ADM3491-1** is a low power, differential line transceiver designed to operate using a single 3.3 V power supply. Low power consumption, coupled with a shutdown mode, makes it ideal for power-sensitive applications. It is suitable for communication on multipoint bus transmission lines.

The **ADM3491-1** is intended for balanced data transmission and complies with both Electronic Industries Association (EIA) Standards RS-485 and RS-422. It contains a differential line driver and a differential line receiver, making it suitable for full-duplex data transfer.

## FUNCTIONAL BLOCK DIAGRAM

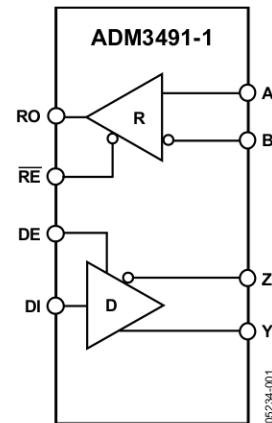

Figure 1.

The input impedance is 19 k $\Omega$ , allowing up to 50 transceivers to be connected on the bus. A thermal shutdown circuit prevents excessive power dissipation caused by bus contention or by output shorting. This feature forces the driver output into a high impedance state if a significant temperature increase is detected in the internal driver circuitry during fault conditions.

If the inputs are unconnected (floating), the receiver contains a fail-safe feature that results in a logic high output state.

The **ADM3491-1** is fabricated on BiCMOS, an advanced mixed technology process combining low power CMOS with fast switching bipolar technology.

Rev. C

[Document Feedback](#)

Information furnished by Analog Devices is believed to be accurate and reliable. However, no responsibility is assumed by Analog Devices for its use, nor for any infringements of patents or other rights of third parties that may result from its use. Specifications subject to change without notice. No license is granted by implication or otherwise under any patent or patent rights of Analog Devices. Trademarks and registered trademarks are the property of their respective owners.

**TABLE OF CONTENTS**

|  |   |   |    |
|--|---|---|----|
| Features .....                                     | 1 | Typical Performance Characteristics .....     | 7  |
| Applications.....                                  | 1 | Test Circuits.....                            | 9  |
| General Description .....                          | 1 | Switching Characteristics .....               | 10 |
| Functional Block Diagram .....                     | 1 | Theory of Operation .....                     | 11 |
| Revision History .....                             | 2 | Differential Data Transmission .....          | 11 |
| Specifications.....                                | 3 | Cable and Data Rate.....                      | 11 |
| Timing Specifications .....                        | 4 | Receiver Open-Circuit Fail-Safe Feature ..... | 11 |
| Absolute Maximum Ratings.....                      | 5 | Outline Dimensions .....                      | 12 |
| ESD Caution.....                                   | 5 | Ordering Guide .....                          | 13 |
| Pin Configurations and Function Descriptions ..... | 6 |   |    |

**REVISION HISTORY**

**6/14—Rev. B to Rev. C**

|                                 |    |
|---------------------------------|----|
| Changes to Ordering Guide ..... | 13 |
|---------------------------------|----|

**10/06—Rev. A to Rev. B**

|   |           |
|---|-----------|
| Changes to Part Number .....            | Universal |
| Updated Format.....                     | Universal |
| Changes to Features.....                | 1         |
| Changes to General Description .....    | 1         |
| Changes to Table 2.....                 | 4         |
| Changes to Table 3.....                 | 4         |
| Changes to Figure 24 and Figure 25..... | 10        |
| Changes to Table 8.....                 | 11        |
| Updated Outline Dimensions .....        | 12        |
| Changes to Ordering Guide .....         | 13        |

**11/04—Rev. 0 to Rev. A**

|  |           |
|--|-----------|
| Format Updated.....                    | Universal |
| Changes to Specifications Section..... | 3         |
| Changes to Ordering Guide .....        | 13        |

**1/98—Revision 0: Initial Version**

## SPECIFICATIONS

$V_{CC} = 3.3 \text{ V} \pm 0.3 \text{ V}$ . All specifications  $T_{MIN}$  to  $T_{MAX}$ , unless otherwise noted.

Table 1.

| Parameter  | Min                      | Typ   | Max       | Unit             | Test Conditions/Comments  |
|--|--------------------------|-------|-----------|------------------|---|
| <b>DRIVER</b>                                    |                          |       |           |                  |   |
| Differential Output Voltage, $V_{OD}$            | 2.0                      |       |           | V                | $R_L = 100 \Omega$ , $V_{CC} > 3.1 \text{ V}$ , see Figure 14                       |
|  | 1.5                      |       |           | V                | $R_L = 54 \Omega$ , see Figure 14   |
|  | 1.5                      |       |           | V                | $R_L = 60 \Omega$ , $-7 \text{ V} < V_{TST} < +12 \text{ V}$ , see Figure 15        |
| $\Delta V_{OD} $ for Complementary Output States |                          |       | 0.2       | V                | $R = 54 \Omega$ or $100 \Omega$ , see Figure 14                                     |
| Common-Mode Output Voltage, $V_{OC}$             |                          |       | 3         | V                | $R = 54 \Omega$ or $100 \Omega$ , see Figure 14                                     |
| $\Delta V_{OC} $ for Complementary Output States |                          |       | 0.2       | V                | $R = 54 \Omega$ or $100 \Omega$ , see Figure 14                                     |
| CMOS Input Logic Threshold Low, $V_{INL}$        |                          |       | 0.8       | V                |   |
| CMOS Input Logic Threshold High, $V_{INH}$       | 2.0                      |       |           | V                |   |
| Logic Input Current (DE, DI, $\overline{RE}$ )   |                          |       | $\pm 1.0$ | $\mu\text{A}$    |   |
| Output Leakage (Y, Z) Current                    |                          |       | $\pm 3$   | $\mu\text{A}$    | $V_O = -7 \text{ V}$ or $+12 \text{ V}$ , $V_{CC} = 0 \text{ V}$ or $3.6 \text{ V}$ |
| Output Short-Circuit Current                     |                          |       | $\pm 250$ | $\text{mA}$      | $V_O = -7 \text{ V}$ or $+12 \text{ V}$   |
| <b>RECEIVER</b>                                  |                          |       |           |                  |   |
| Differential Input Threshold Voltage, $V_{TH}$   | -0.2                     |       | +0.2      | V                | $-7 \text{ V} < V_{CM} < +12 \text{ V}$   |
| Input Voltage Hysteresis, $\Delta V_{TH}$        |                          | 50    |           | mV               | $V_{CM} = 0 \text{ V}$  |
| Input Resistance                                 | 12                       | 19    |           | $\text{k}\Omega$ | $-7 \text{ V} < V_{CM} < +12 \text{ V}$   |
| Input Current (A, B)                             |                          |       | 1         | $\text{mA}$      | $V_{IN} = 12 \text{ V}$   |
|  |                          |       | -0.8      | $\text{mA}$      | $V_{IN} = -7 \text{ V}$   |
| Logic Enable Input Current ( $\overline{RE}$ )   |                          |       | $\pm 1$   | $\mu\text{A}$    |   |
| Output Voltage Low, $V_{OL}$                     |                          |       | 0.4       | V                | $I_{OUT} = +2.5 \text{ mA}$   |
| Output Voltage High, $V_{OH}$                    | $V_{CC} - 0.4 \text{ V}$ |       |           | V                | $I_{OUT} = -1.5 \text{ mA}$   |
| Short-Circuit Output Current                     |                          |       | $\pm 60$  | $\text{mA}$      | $V_{OUT} = \text{GND}$ or $V_{CC}$  |
| Three-State Output Leakage Current               |                          |       | $\pm 1.0$ | $\mu\text{A}$    | $V_{CC} = 3.6 \text{ V}$ , $0 \text{ V} < V_{OUT} < V_{CC}$                         |
| <b>POWER SUPPLY CURRENT</b>                      |                          |       |           |                  |   |
| $I_{CC}$   |                          | 0.84  | 1.5       | $\text{mA}$      | Outputs unloaded<br>$DE = V_{CC}$ , $\overline{RE} = 0 \text{ V}$                   |
|  |                          | 0.84  | 1.5       | $\text{mA}$      | $DE = 0 \text{ V}$ , $\overline{RE} = 0 \text{ V}$                                  |
| Supply Current in Shutdown                       |                          | 0.002 | 1         | $\mu\text{A}$    | $DE = 0 \text{ V}$ , $\overline{RE} = V_{CC}$                                       |

**TIMING SPECIFICATIONS**

$V_{CC} = 3.3\text{ V}$ ,  $T_A = 25^\circ\text{C}$ , unless otherwise noted.

**Table 2.**

| Parameter  | Min | Typ | Max | Unit | Test Conditions/ Comments   |
|--|-----|-----|-----|------|---|
| <b>DRIVER</b>  |     |     |     |      |   |
| Differential Output Delay, $T_{DD}$                      | 1   |     | 35  | ns   | $R_L = 60\ \Omega$ , $C_{L1} = C_{L2} = 15\text{ pF}$ , see Figure 18 |
| Differential Output Transition Time                      | 1   | 8   | 15  | ns   | $R_L = 60\ \Omega$ , $C_{L1} = C_{L2} = 15\text{ pF}$ , see Figure 18 |
| Propagation Delay Input to Output, $T_{PLH}$ , $T_{PHL}$ | 7   | 22  | 35  | ns   | $R_L = 27\ \Omega$ , $C_{L1} = C_{L2} = 15\text{ pF}$ , see Figure 19 |
| Driver Output to Output, $T_{SKEW}$                      |     |     | 8   | ns   | $R_L = 54\ \Omega$ , $C_{L1} = C_{L2} = 15\text{ pF}$ , see Figure 19 |
| <b>ENABLE/DISABLE</b>                                    |     |     |     |      |   |
| Driver Enable to Output Valid                            |     | 45  | 90  | ns   | $R_L = 110\ \Omega$ , $C_L = 50\text{ pF}$ , see Figure 16            |
| Driver Disable Timing                                    |     | 40  | 80  | ns   | $R_L = 110\ \Omega$ , $C_L = 50\text{ pF}$ , see Figure 16            |
| Driver Enable from Shutdown                              |     | 65  | 110 | ns   | $R_L = 110\ \Omega$ , $C_L = 15\text{ pF}$ , see Figure 16            |
| <b>RECEIVER</b>  |     |     |     |      |   |
| Time to Shutdown   | 80  | 190 | 300 | ns   |   |
| Propagation Delay Input to Output, $T_{PLH}$ , $T_{PHL}$ | 25  | 65  | 90  | ns   | $C_L = 15\text{ pF}$ , see Figure 21                                  |
| Skew, $T_{PLH} - T_{PHL}$                                |     |     | 10  | ns   | $C_L = 15\text{ pF}$ , see Figure 21                                  |
| Receiver Enable, $T_{EN}$                                |     | 25  | 50  | ns   | $C_L = 15\text{ pF}$ , see Figure 17                                  |
| Receiver Disable, $T_{DEN}$                              |     | 25  | 45  | ns   | $C_L = 15\text{ pF}$ , see Figure 17                                  |
| Receiver Enable from Shutdown                            |     |     | 500 | ns   | $C_L = 15\text{ pF}$ , see Figure 17                                  |

$V_{CC} = 3.3\text{ V} \pm 0.3\text{ V}$ ,  $T_A = T_{MIN}$  to  $T_{MAX}$ , unless otherwise noted.

**Table 3.**

| Parameter  | Min | Typ | Max | Unit | Test Conditions/Comments  |
|--|-----|-----|-----|------|---|
| <b>DRIVER</b>  |     |     |     |      |   |
| Differential Output Delay, $T_{DD}$                      | 1   |     | 70  | ns   | $R_L = 60\ \Omega$ , $C_{L1} = C_{L2} = 15\text{ pF}$ , see Figure 18 |
| Differential Output Transition Time                      | 2   | 8   | 15  | ns   | $R_L = 60\ \Omega$ , $C_{L1} = C_{L2} = 15\text{ pF}$ , see Figure 18 |
| Propagation Delay Input to Output, $T_{PLH}$ , $T_{PHL}$ | 7   | 22  | 70  | ns   | $R_L = 27\ \Omega$ , $C_{L1} = C_{L2} = 15\text{ pF}$ , see Figure 19 |
| Driver Output to Output, $T_{SKEW}$                      |     |     | 10  | ns   | $R_L = 54\ \Omega$ , $C_{L1} = C_{L2} = 15\text{ pF}$ , see Figure 19 |
| <b>ENABLE/DISABLE</b>                                    |     |     |     |      |   |
| Driver Enable to Output Valid                            |     | 45  | 110 | ns   | $R_L = 110\ \Omega$ , $C_L = 50\text{ pF}$ , see Figure 16            |
| Driver Disable Timing                                    |     | 40  | 110 | ns   | $R_L = 110\ \Omega$ , $C_L = 50\text{ pF}$ , see Figure 16            |
| Driver Enable from Shutdown                              |     | 65  | 110 | ns   | $R_L = 110\ \Omega$ , $C_L = 15\text{ pF}$ , see Figure 16            |
| <b>RECEIVER</b>  |     |     |     |      |   |
| Time to Shutdown   | 50  | 190 | 500 | ns   |   |
| Propagation Delay Input to Output, $T_{PLH}$ , $T_{PHL}$ | 25  | 65  | 115 | ns   | $C_L = 15\text{ pF}$ , see Figure 21                                  |
| Skew, $T_{PLH} - T_{PHL}$                                |     |     | 20  | ns   | $C_L = 15\text{ pF}$ , see Figure 21                                  |
| Receiver Enable, $T_{EN}$                                |     | 25  | 50  | ns   | $C_L = 15\text{ pF}$ , see Figure 17                                  |
| Receiver Disable, $T_{DEN}$                              |     | 25  | 50  | ns   | $C_L = 15\text{ pF}$ , see Figure 17                                  |
| Receiver Enable from Shutdown                            |     |     | 600 | ns   | $C_L = 15\text{ pF}$ , see Figure 17                                  |

## ABSOLUTE MAXIMUM RATINGS

$T_A = 25^\circ\text{C}$ , unless otherwise noted.

**Table 4.**

| Parameter                                    | Rating                                    |
|--|---|
| $V_{CC}$                                     | 7 V                                       |
| Inputs                                       |   |
| Driver Input (DI)                            | $-0.3\text{ V to }V_{CC} + 0.3\text{ V}$  |
| Control Inputs (DE, $\overline{\text{RE}}$ ) | $-0.3\text{ V to }V_{CC} + 0.3\text{ V}$  |
| Receiver Inputs (A, B)                       | $-7.5\text{ V to }+12.5\text{ V}$         |
| Outputs                                      |   |
| Driver Outputs                               | $-7.5\text{ V to }+12.5\text{ V}$         |
| Receiver Output                              | $-0.5\text{ V to }V_{CC} + 0.5\text{ V}$  |
| 14-Lead PDIP, Power Dissipation              | 800 mW                                    |
| $\theta_{JA}$ , Thermal Impedance            | $140^\circ\text{C/W}$                     |
| 14-Lead SOIC, Power Dissipation              | 650 mW                                    |
| $\theta_{JA}$ , Thermal Impedance            | $115^\circ\text{C/W}$                     |
| 16-Lead TSSOP, Power Dissipation             | 500 mW                                    |
| $\theta_{JA}$ , Thermal Impedance            | $158^\circ\text{C/W}$                     |
| Operating Temperature Range                  |   |
| Industrial (A Version)                       | $-40^\circ\text{C to }+85^\circ\text{C}$  |
| Storage Temperature Range                    | $-65^\circ\text{C to }+150^\circ\text{C}$ |
| Lead Temperature (Soldering, 10 sec)         | $300^\circ\text{C}$                       |
| Vapor Phase (60 sec)                         | $215^\circ\text{C}$                       |
| Infrared (15 sec)                            | $220^\circ\text{C}$                       |
| ESD Rating                                   | $>2\text{ kV}$                            |
| EFT Rating (IEC1000-4-4)                     | $>1\text{ kV}$                            |

Stresses above those listed under Absolute Maximum Ratings may cause permanent damage to the device. This is a stress rating only; functional operation of the device at these or any other conditions above those indicated in the operational section of this specification is not implied. Exposure to absolute maximum rating conditions for extended periods may affect device reliability.

### ESD CAUTION



**ESD (electrostatic discharge) sensitive device.** Charged devices and circuit boards can discharge without detection. Although this product features patented or proprietary protection circuitry, damage may occur on devices subjected to high energy ESD. Therefore, proper ESD precautions should be taken to avoid performance degradation or loss of functionality.

## PIN CONFIGURATIONS AND FUNCTION DESCRIPTIONS

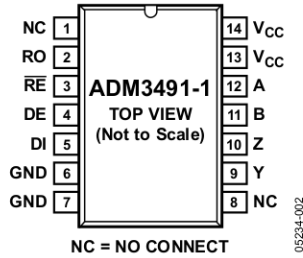

Figure 2. 14-Lead PDIP and 14-Lead SOIC Pin Configuration

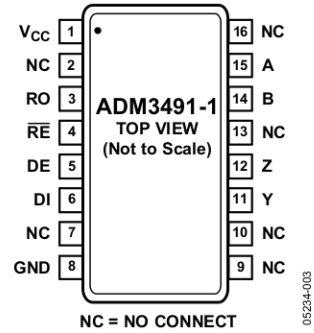

Figure 3. 16-Lead TSSOP Pin Configuration

Table 5. Pin Function Descriptions

| Pin Number |                     | Mnemonic        | Description  |
|------------|---------------------|-----------------|--|
| PDIP/SOIC  | TSSOP               |                 |  |
| 1, 8       | 2, 7, 9, 10, 13, 16 | NC              | No Connect.  |
| 2          | 3                   | RO              | Receiver Output. High when $A > B$ by 200 mV; low when $A < B$ by 200 mV.  |
| 3          | 4                   | $\overline{RE}$ | Receiver Output Enable. When $\overline{RE}$ is low, the receiver output RO is enabled. When $\overline{RE}$ is high, the output is high impedance. If $\overline{RE}$ is high and DE is low, the ADM3491-1 enters a shutdown state. |
| 4          | 5                   | DE              | Driver Output Enable. A high level enables the driver differential outputs, Y and Z. A low level places the part in a high impedance state.  |
| 5          | 6                   | DI              | Driver Input. When the driver is enabled, a logic low on DI forces Y low and Z high; a logic high on DI forces Y high and Z low.   |
| 6, 7       | 8                   | GND             | Ground Connection, 0V.   |
| 9          | 11                  | Y               | Noninverting Driver Output Y.  |
| 10         | 12                  | Z               | Inverting Driver Output Z.   |
| 11         | 14                  | B               | Inverting Receiver Input B.  |
| 12         | 15                  | A               | Noninverting Receiver Input A.   |
| 13, 14     | 1                   | V <sub>CC</sub> | Power Supply, 3.3 V $\pm$ 0.3 V.   |

### TYPICAL PERFORMANCE CHARACTERISTICS

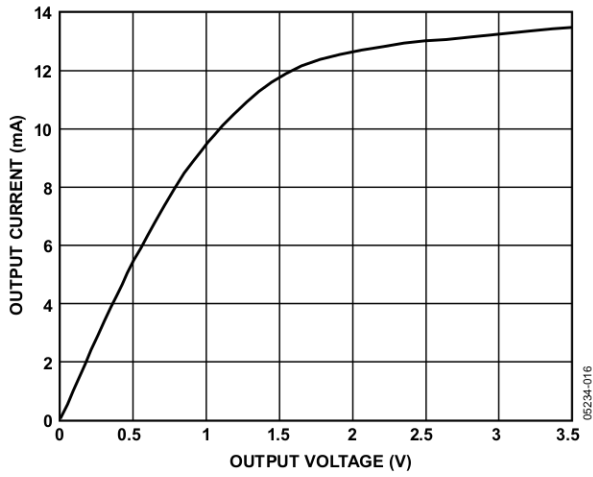

Figure 4. Output Current vs. Receiver Output Low Voltage

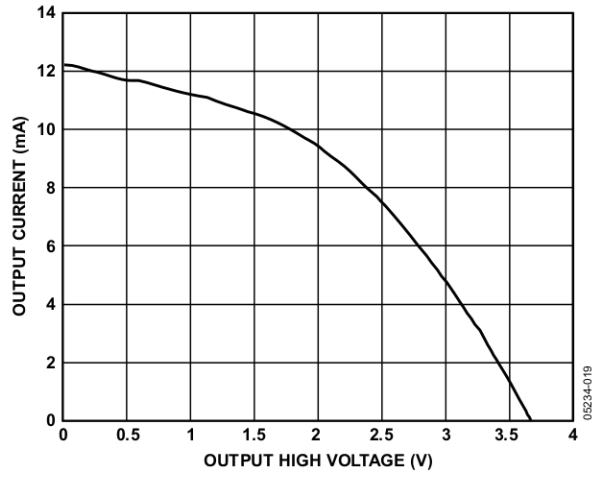

Figure 7. Output Current vs. Receiver Output High Voltage

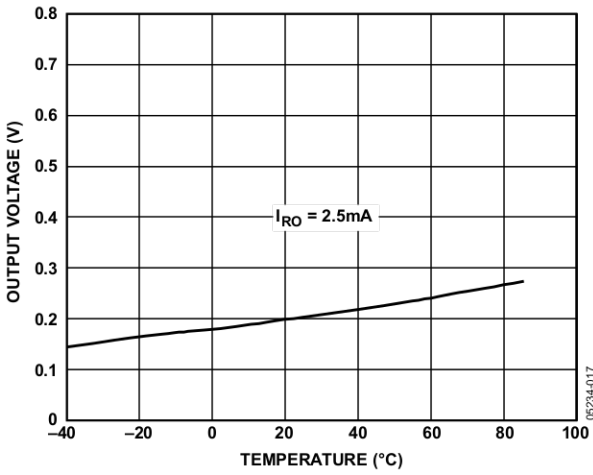

Figure 5. Receiver Output Low Voltage vs. Temperature

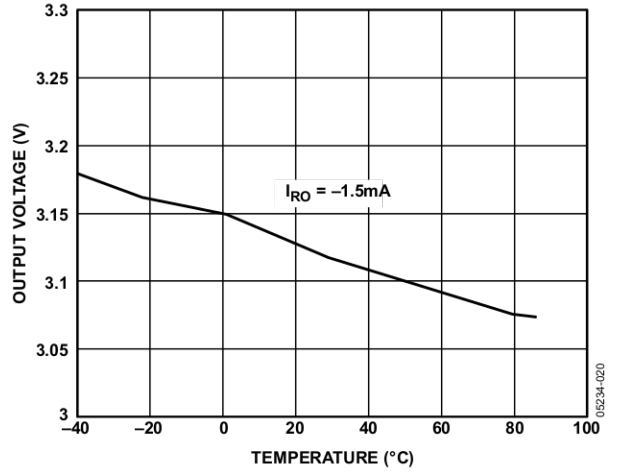

Figure 8. Receiver Output High Voltage vs. Temperature

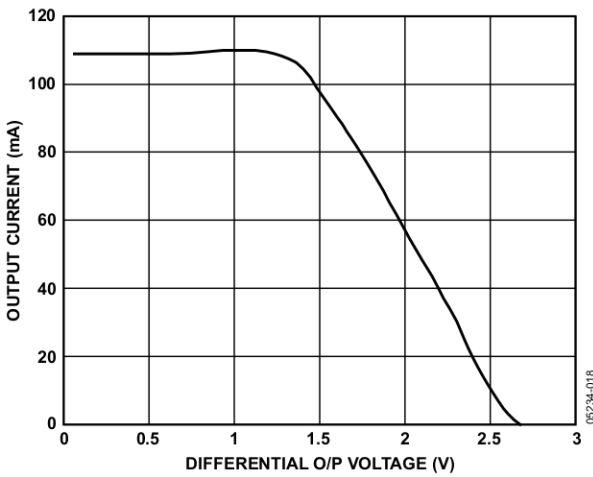

Figure 6. Output Current vs. Driver Differential Output Voltage

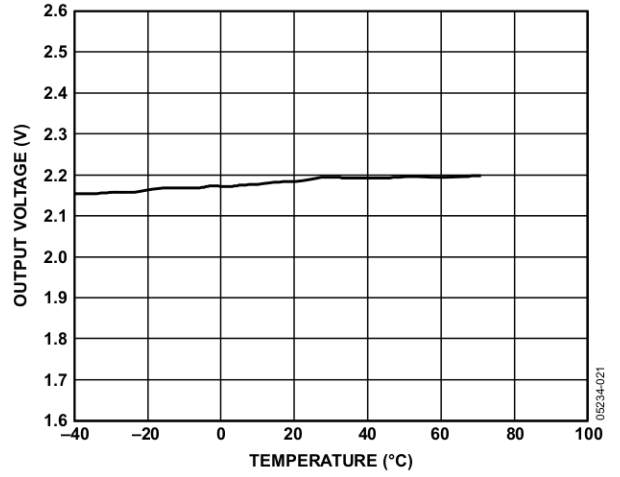

Figure 9. Driver Differential Output Voltage vs. Temperature

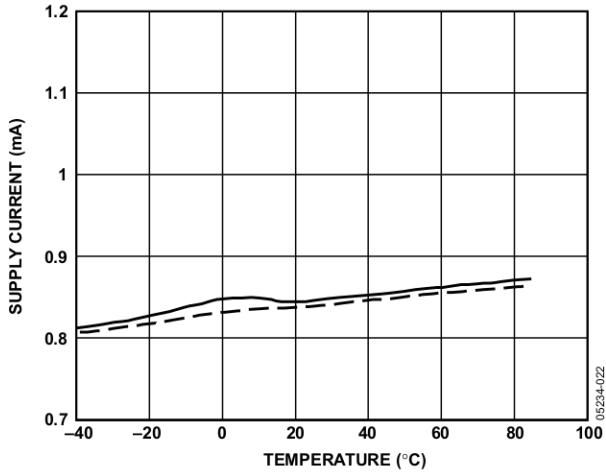

Figure 10. Supply Current vs. Temperature

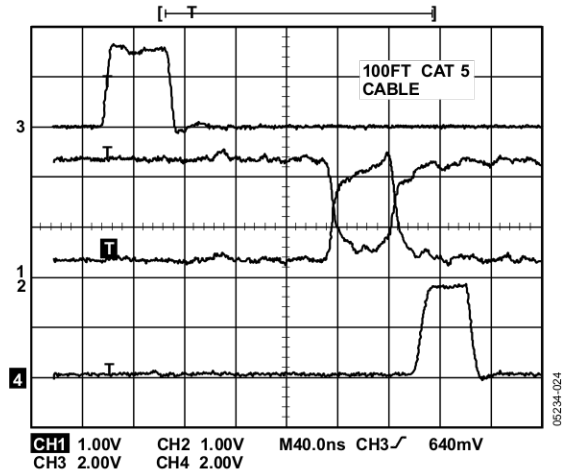

Figure 12. Driving 100 ft. Cable H-L Transition

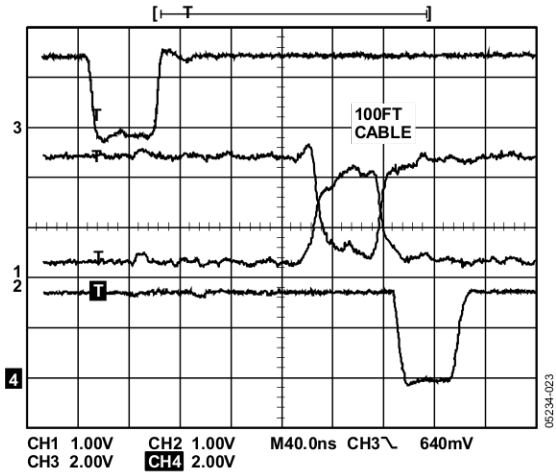

Figure 11. Driving 100 ft. Cable L-H Transition

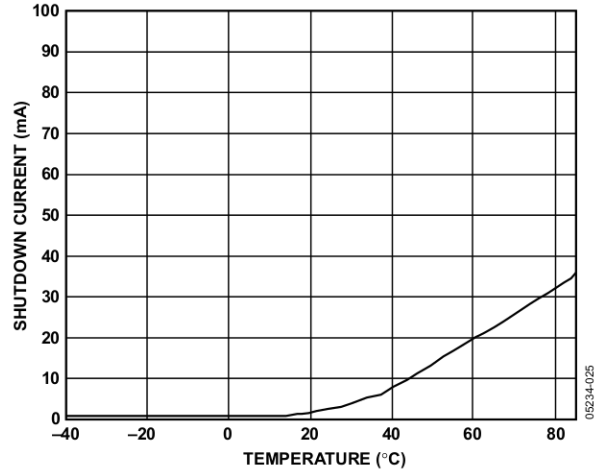

Figure 13. Shutdown Current vs. Temperature



TEST CIRCUITS

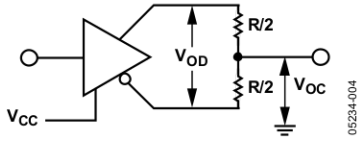

Figure 14. Driver Voltage Measurement Test Circuit

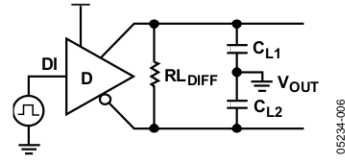

Figure 18. Driver Differential Output Delay Test Circuit

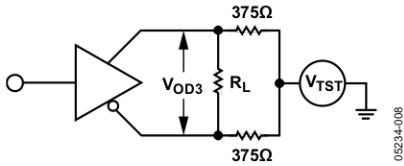

Figure 15. Driver Voltage Measurement Test Circuit 2

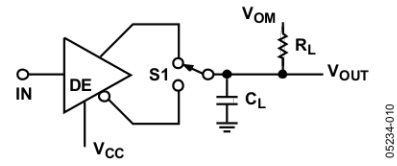

Figure 19. Driver Propagation Delay Test Circuit

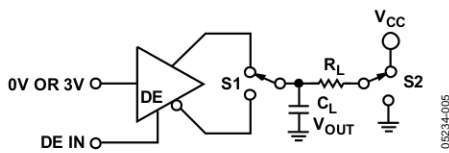

Figure 16. Driver Enable/Disable Test Circuit

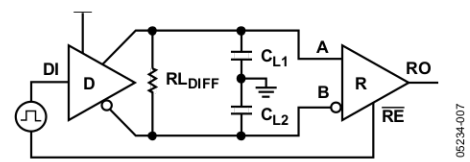

Figure 20. Driver/Receiver Propagation Delay Test Circuit

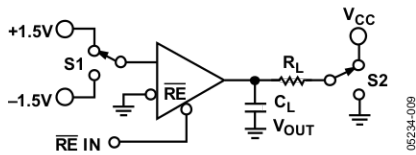

Figure 17. Receiver Enable/Disable Test Circuit

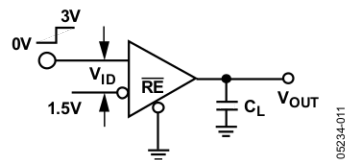

Figure 21. Receiver Propagation Delay Test Circuit

SWITCHING CHARACTERISTICS

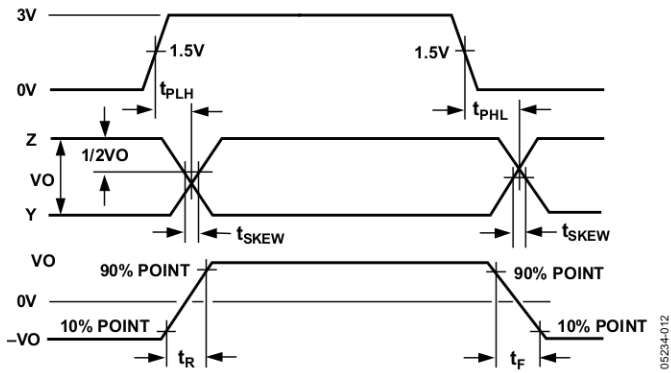

Figure 22. Driver Propagation Delay, Rise/Fall Timing

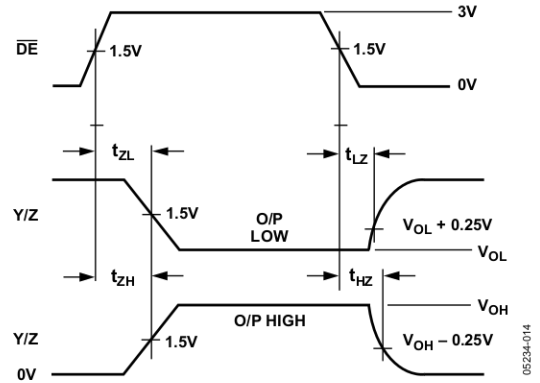

Figure 24. Driver Enable/Disable Timing

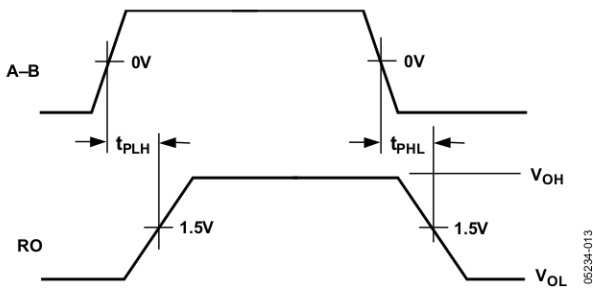

Figure 23. Receiver Propagation Delay

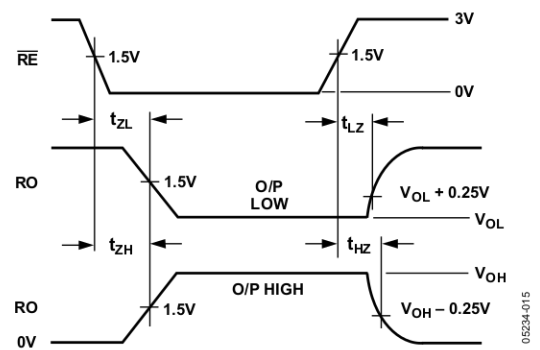

Figure 25. Receiver Enable/Disable Timing

## THEORY OF OPERATION

### DIFFERENTIAL DATA TRANSMISSION

Differential data transmission is used to reliably transmit data at high rates over long distances and through noisy environments. Differential transmission nullifies the effects of ground shifts and noise signals that appear as common-mode voltages on the line.

The two main standards approved by the EIA specify the electrical characteristics of transceivers used in differential data transmission:

- RS-422 standard specifies data rates up to 10 MBaud and line lengths up to 4000 ft. A single driver can drive a transmission line with up to 10 receivers.
- RS-485 standard was defined to cater to true multipoint communications. This standard meets or exceeds all the requirements of RS-422, but also allows multiple drivers and receivers to be connected to a single bus. An extended common-mode range of  $-7\text{ V}$  to  $+12\text{ V}$  is defined.

The most significant differentiator of the RS-485 standard is that the drivers can be disabled, thereby allowing more than one to be connected to a single line. Only one driver should be enabled at a time, but the RS-485 standard contains additional specifications to guarantee device safety in the event of line contention.

Table 6. Comparison of RS-422 and RS-485 Interface Standards

| Specification                 | RS-422                         | RS-485                          |
|-------------------------------|--------------------------------|---------------------------------|
| Transmission Type             | Differential                   | Differential                    |
| Maximum Cable Length          | 4000 ft.                       | 4000 ft.                        |
| Minimum Driver Output Voltage | $\pm 2\text{ V}$               | $\pm 1.5\text{ V}$              |
| Driver Load Impedance         | $100\ \Omega$                  | $54\ \Omega$                    |
| Receiver Input Resistance     | $4\text{ k}\Omega$ min         | $12\text{ k}\Omega$ min         |
| Receiver Input Sensitivity    | $\pm 200\text{ mV}$            | $\pm 200\text{ mV}$             |
| Receiver Input Voltage Range  | $-7\text{ V}$ to $+7\text{ V}$ | $-7\text{ V}$ to $+12\text{ V}$ |

### CABLE AND DATA RATE

The transmission line of choice for RS-485 communications is a twisted pair. Twisted pair cable tends to cancel common-mode noise and also causes cancellation of the magnetic fields generated by the current flowing through each wire, thereby reducing the effective inductance of the pair.

The ADM3491-1 is designed for bidirectional data communications on multipoint transmission lines. A typical application showing a multipoint transmission network is illustrated in Figure 26. Only one driver can transmit at a particular time, but multiple receivers can be enabled simultaneously.

As with any transmission line, it is important that reflections be minimized. This can be achieved by terminating the extreme ends of the line using resistors equal to the characteristic impedance of the line. Stub lengths of the main line should also be kept as short as possible. A properly terminated transmission line appears purely resistive to the driver.

### RECEIVER OPEN-CIRCUIT FAIL-SAFE FEATURE

The receiver input includes a fail-safe feature that guarantees a logic high on the receiver when the inputs are open circuit or floating.

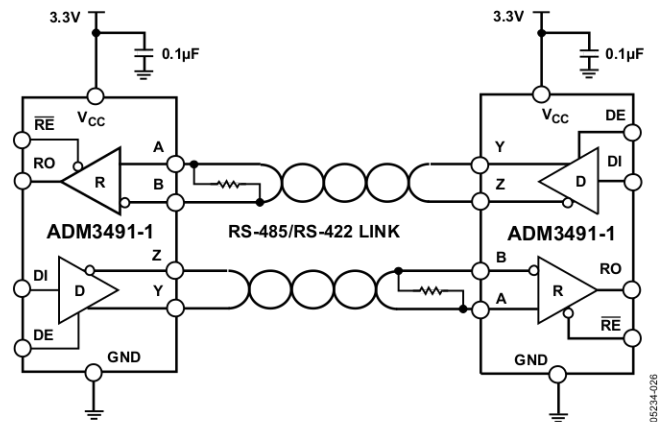

Figure 26. ADM3491-1 Full-Duplex Data Link

Table 7. Transmitting Truth Table

| Inputs |    |    | Outputs |      |
|--------|----|----|---------|------|
| RE     | DE | DI | Z       | Y    |
| X      | 1  | 1  | 0       | 1    |
| X      | 1  | 0  | 1       | 0    |
| 0      | 0  | X  | Hi-Z    | Hi-Z |
| 1      | 0  | X  | Hi-Z    | Hi-Z |

Table 8. Receiving Truth Table

| Inputs |    |                      | Outputs |
|--------|----|----------------------|---------|
| RE     | DE | A-B                  | RO      |
| 0      | X  | $\geq +0.2\text{ V}$ | 0       |
| 0      | X  | $\leq -0.2\text{ V}$ | 0       |
| 0      | X  | Inputs O/C           | 1       |
| 1      | X  | X                    | Hi-Z    |

OUTLINE DIMENSIONS

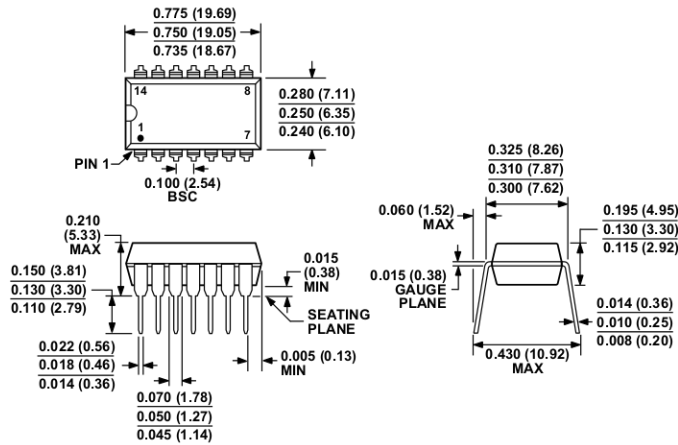

COMPLIANT TO JEDEC STANDARDS MS-001-AA  
 CONTROLLING DIMENSIONS ARE IN INCHES; MILLIMETER DIMENSIONS (IN PARENTHESES) ARE ROUNDED-OFF INCH EQUIVALENTS FOR REFERENCE ONLY AND ARE NOT APPROPRIATE FOR USE IN DESIGN. CORNER LEADS MAY BE CONFIGURED AS WHOLE OR HALF LEADS.

Figure 27. 14-Lead Plastic Dual In-Line Package [PDIP] Narrow Body (N-14)  
 Dimensions shown in inches and (millimeters)

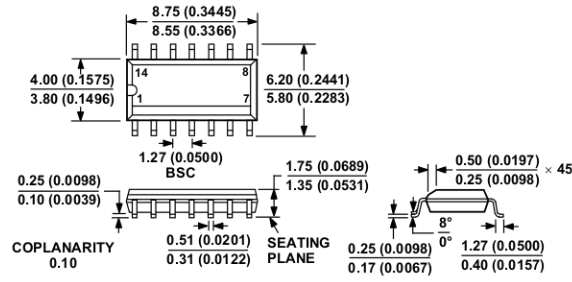

COMPLIANT TO JEDEC STANDARDS MS-012-AB  
 CONTROLLING DIMENSIONS ARE IN MILLIMETERS; INCH DIMENSIONS (IN PARENTHESES) ARE ROUNDED-OFF MILLIMETER EQUIVALENTS FOR REFERENCE ONLY AND ARE NOT APPROPRIATE FOR USE IN DESIGN.

Figure 28. 14-Lead Standard Small Outline Package [SOIC\_N] Narrow Body (R-14)  
 Dimensions shown in millimeters and (inches)

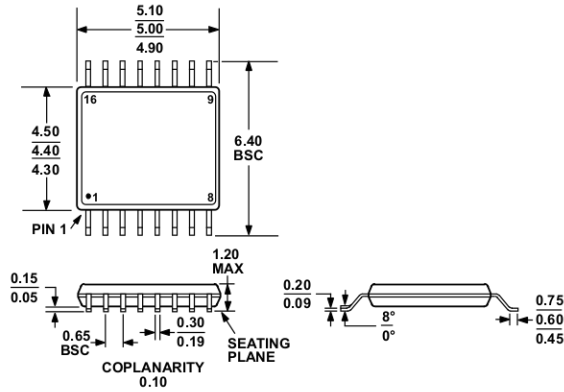

COMPLIANT TO JEDEC STANDARDS MO-153-AB

Figure 29. 16-Lead Thin Shrink Small Outline Package [TSSOP] (RU-16)  
 Dimensions shown in millimeters

**ORDERING GUIDE**

| <b>Model<sup>1</sup></b> | <b>Temperature Range</b> | <b>Package Description</b>                | <b>Package Option</b> | <b>Ordering Quantity</b> |
|--------------------------|--------------------------|---|-----------------------|--------------------------|
| ADM3491ANZ-1             | -40°C to +85°C           | 14-Lead Plastic DIP                       | N-14                  |                          |
| ADM3491AR-1              | -40°C to +85°C           | 14-Lead Narrow Body Small Outline [SOIC]  | R-14                  |                          |
| ADM3491ARZ-1             | -40°C to +85°C           | 14-Lead Narrow Body Small Outline [SOIC]  | R-14                  |                          |
| ADM3491ARZ-1REEL         | -40°C to +85°C           | 14-Lead Narrow Body Small Outline [SOIC]  | R-14                  | 2,500                    |
| ADM3491ARZ-1REEL7        | -40°C to +85°C           | 14-Lead Narrow Body Small Outline [SOIC]  | R-14                  | 1,000                    |
| ADM3491ARU-1             | -40°C to +85°C           | 16-Lead Thin Shrink Small Outline [TSSOP] | RU-16                 |                          |
| ADM3491ARU-1REEL         | -40°C to +85°C           | 16-Lead Thin Shrink Small Outline [TSSOP] | RU-16                 | 2,500                    |
| ADM3491ARUZ-1            | -40°C to +85°C           | 16-Lead Thin Shrink Small Outline [TSSOP] | RU-16                 |                          |
| ADM3491ARUZ-1REEL        | -40°C to +85°C           | 16-Lead Thin Shrink Small Outline [TSSOP] | RU-16                 | 2,500                    |
| ADM3491ARUZ-1REEL7       | -40°C to +85°C           | 16-Lead Thin Shrink Small Outline [TSSOP] | RU-16                 | 1,000                    |

<sup>1</sup> Z = RoHS Compliant Part.

**NOTES**

**NOTES**

**NOTES**