

# PIEZO BUZZER

|                   |               |
|-------------------|---------------|
| Customer          |               |
| Customer P/O      |               |
| Bestar Model Name | BPT-22A       |
| Product No.       | 031300        |
| Issue No.         | BS/TEP01.031A |
| Issue Date        | 01/06/10      |

Approval:

- 1.Technical Terms
- 2.Drawing
- 3.Reliability Test



BESTAR ELECTRONICS INDUSTRY CO.,LTD  
TianAn Industry Park4/F,Site B ChangZhou New District  
Tel:86-519-5103228  
Fax:86-519-5131010  
Http:www.be-star.com  
E-Mail:bestarco@pub.cz.jsinfo.net

## BPT-22A

### 1. Technical Terms

| No. | Item                        | Unit | Specifications |
|-----|-----------------------------|------|----------------|
| 1   | Rated Voltage(Square wave)  | Vp-p | 3              |
| 2   | Operating Voltage           | Vp-p | 1...30         |
| 3   | a)Rated Current             | mA   | 1              |
| 4   | Capacitance at 120Hz        | pF   | 18000± 30%     |
| 5   | a)Sound Output at 2KHz 10cm | dB   | min 70         |
| 6   | Resonant Frequency          | Hz   | 2000± 500      |
| 7   | Operating Temperature       | °C   | -20...+70      |
| 8   | Storage Temperature         | °C   | -30...+80      |
| 9   | Base Plate                  |      | Cu             |
| 10  | Weight                      | g    | 2              |

a)Value applying at rated voltage.

### Standard Output Measurement Setup

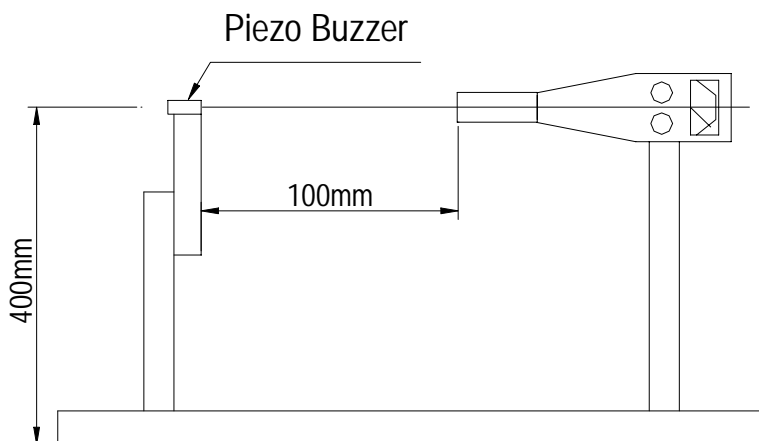

This print and information therein are proprietary to Bestar Electronics Industry Co., Ltd. and shall not be used in whole or in part without its written content. №031300

|   |  |      |  |                                     |                         |
|---|--|------|--|-------------------------------------|-------------------------|
| DIS.  |  | DATE |  | Page:1 of 3<br>3rd angle projection | BPT-22A                 |
| CHEC.   |  | DATE |  |                                     |                         |
| APPR.   |  | DATE |  |                                     | Piezo Buzzer            |
|  <b>BESTAR ELECTRONICS INDUSTRY CO.,LTD</b><br>TianAn Industry Park 4/F,Site B ChangZhou New District<br>E-Mail:bestarco@ pub.cz.jsinfo.net Http:www.be-star.com |  |      |  |                                     | DRG NO<br>BS/TEP01.031A |

## BPT-22A

### 2. Drawing

Tolerance:  $\pm 0.5$

Unit:mm

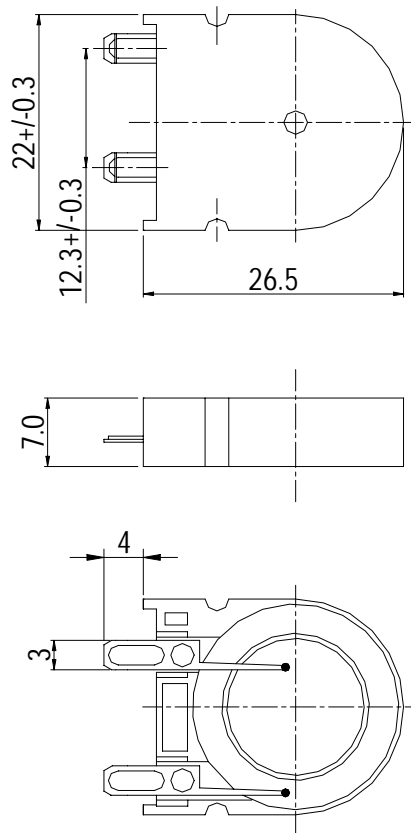

This print and information therein are proprietary to Bestar Electronics Industry Co., Ltd. and shall not be used in whole or in part without its written content. No.031300

|   |  |      |  |                                     |                         |
|---|--|------|--|-------------------------------------|-------------------------|
| DIS.  |  | DATE |  | Page:2 of 3<br>3rd angle projection | BPT-22A                 |
| CHEC.   |  | DATE |  |                                     |                         |
| APPR.   |  | DATE |  |                                     | Piezo Buzzer            |
|  <b>BESTAR ELECTRONICS INDUSTRY CO.,LTD</b><br>TianAn Industry Park 4/F,Site B ChangZhou New District<br>E-Mail:bestarco@ pub.cz.jsinfo.net Http:www.be-star.com |  |      |  |                                     | DRG NO<br>BS/TEP01.031A |

## BPT-22A

### 3. Reliability Test

#### 3.1 High temperature test

Temperature +80° C  
Duration 96hrs

#### 3.2 Low temperature test

Temperature -30° C  
Duration 96hrs

#### 3.3 Life test in normal temperature

Power supply rated voltage  
Duration 500hrs

#### 3.4 temperature cycle test

Cycles 5

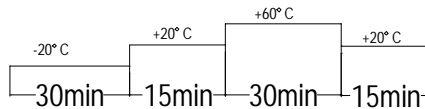

#### 3.5 Humidity cycle test

Cycles 5

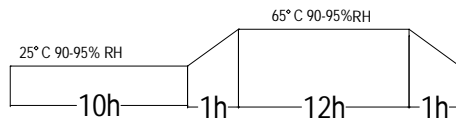

all these tests above should be measured after leaving normal temperature for 2hrs.

#### 3.6 Drop test

Height 70cm  
(to 10mm thickness woodenboard)  
Direction 3

Notice: All specification must be satisfied in this condition.except S.P.L, S.P.L shall be 65dB more .

This print and information therein are proprietary to Bestar Electronics Industry Co., Ltd. and shall not be used in whole or in part without its written content №031300

|   |  |      |  |                      |                         |
|---|--|------|--|----------------------|-------------------------|
| DIS.  |  | DATE |  | Page:3 of 3          | BPT-22A                 |
| CHEC.   |  | DATE |  | 3rd angle projection | Piezo Buzzer            |
| APPR.   |  | DATE |  |                      |                         |
|  <b>BESTAR ELECTRONICS INDUSTRY CO.,LTD</b><br>TianAn Industry Park 4/F,Site B ChangZhou New District<br>E-Mail:bestarco@ pub.cz.jsinfo.net Http:www.be-star.com |  |      |  |                      | DRG NO<br>BS/TEP01.031A |