

KYZ35A1 ... KYZ35A6 KYZ35K1 ... KYZ35K6 Standard Recovery Press-fit Rectifier Diodes Einpress-Gleichrichterdioden mit Standard-Sperrverzug	$I_{FAV} = 35 \text{ A}$	$V_{RRM} = 100...600 \text{ V}$
	$V_F < 1.1 \text{ V}$	$I_{FSM} = 360/400 \text{ A}$
	$T_{jmax} = 175^\circ\text{C}$	$t_{rr} \sim 1500 \text{ ns}$

Version 2018-01-05

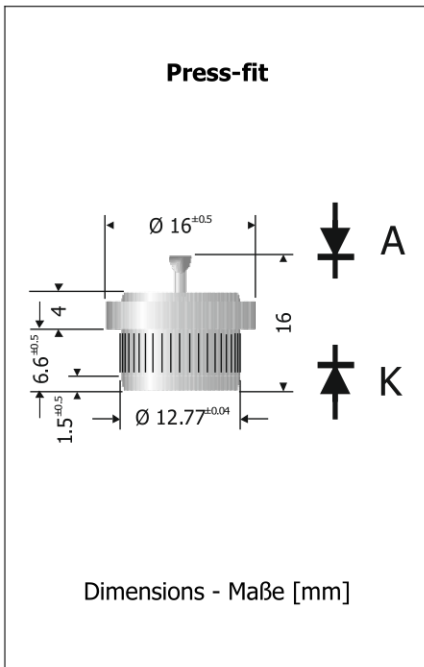

Typical Applications

50/60 Hz Mains Rectification, Power Supplies, Polarity Protection Commercial grade ¹⁾

Features

High junction temperature
 Two polarity versions:
 A = Anode to lead wire
 K = Cathode to lead wire
 For press-fit assembly into aluminium cooling plate
 Compliant to RoHS, REACH, Conflict Minerals ¹⁾

Mechanical Data ¹⁾

Packed in cardboard trays	500
Weight approx.	10 g
Plastic material	UL 94V-0
Solder & assembly conditions	260°C/10s
MSL = N/A	

Typische Anwendungen

50/60 Hz Netzgleichrichtung, Stromversorgungen, Verpolschutz Standardausführung ¹⁾

Besonderheiten

Hohe Sperrschichttemperatur
 Zwei Polaritäten:
 A = Anode am Anschlussdraht
 K = Kathode am Anschlussdraht
 Für Einpressmontage in Alu-Kühlblech
 Konform zu RoHS, REACH, Konfliktmineralien ¹⁾



Mechanische Daten ¹⁾

Verpackt in Einlegekartons	
Gewicht ca.	
Kunststoffmaterial	
Löt- und Einbaubedingungen	

Maximum ratings ²⁾

Grenzwerte ²⁾

Type / Typ Wire to / Draht an Anode Cathode	Repetive peak reverse voltage Periodische Spitzensperrspannung $V_{RRM} [V]$	Surge peak reverse voltage Stoßspitzensperrspannung $V_{RSM} [V]$
KYZ35A1 KYZ35K1	100	100
KYZ35A2 KYZ35K2	200	200
KYZ35A3 KYZ35K3	300	300
KYZ35A4 KYZ35K4	400	400
KYZ35A6 KYZ35K6	600	600

Max. average forward rectified current, R-load Dauergrenzstrom in Einwegschaltung mit R-Last	$T_c = 150^\circ\text{C} \text{ }^3)$	I_{FAV}	35 A
Repetitive peak forward current Periodischer Spitzenstrom	$f > 15 \text{ Hz}$	$T_c = 150^\circ\text{C} \text{ }^3)$	I_{FRM} 130 A
Peak forward surge current Stoßstrom in Fluss-Richtung	Half sine-wave Sinus-Halbwellen	50 Hz (10 ms) 60 Hz (8.3 ms)	I_{FSM} 360 A 400 A
Rating for fusing Grenzlastintegral	$t < 10 \text{ ms}$	i^2t	660 A ² s
Operating junction temperature – Sperrschichttemperatur Storage temperature – Lagerungstemperatur		T_j T_s	-50...+175°C -50...+175°C
Maximum admissible press-in force Maximal zulässige Einpresskraft		F_{pM}	4 kN

1 Please note the [detailed information on our website](#) or at the beginning of the data book
 Bitte beachten Sie die [detaillierten Hinweise auf unserer Internetseite](#) bzw. am Anfang des Datenbuches
 2 $T_A = 25^\circ\text{C}$ unless otherwise specified – $T_A = 25^\circ\text{C}$ wenn nicht anders angegeben
 3 Temperature measured at the metallic base – Temperatur am Metallsockel gemessen

Characteristics
Kennwerte

Forward Voltage Durchlass-Spannung	$T_J = 25^\circ\text{C}$	$I_F = 35\text{ A}$	V_F	$< 1.1\text{ V}$
Leakage Current Sperrstrom	$T_J = 25^\circ\text{C}$	$V_R = V_{RRM}$	I_R	$< 100\ \mu\text{A}$
Typical junction capacitance Typische Sperrschichtkapazität		$V_R = 4\text{ V}$	C_j	250 pF
Reverse recovery time Sperrverzug	$I_F = 0.5\text{ A}$ through/über $I_R = 1\text{ A}$ to $I_R = 0.25\text{ A}$		t_{rr}	typ. 1500 ns
Thermal resistance junction to metallic base Wärmewiderstand Sperrschicht – Metallsockel			R_{thc}	$< 0.8\text{ K/W}^1)$

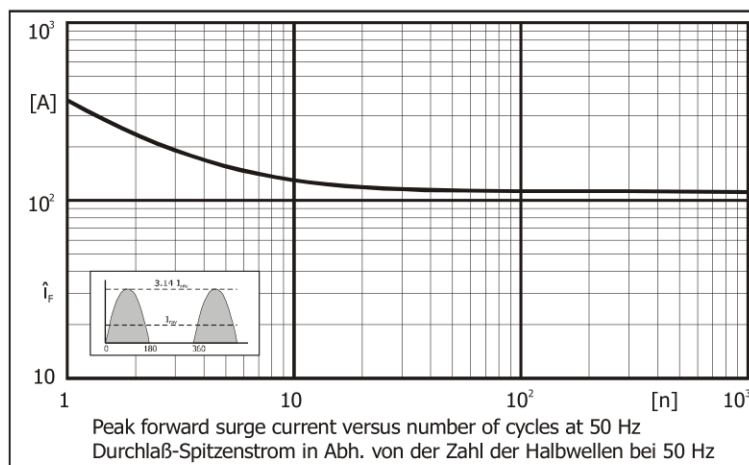
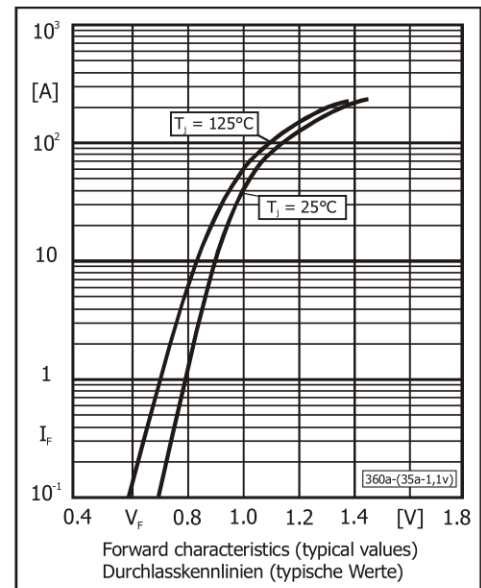
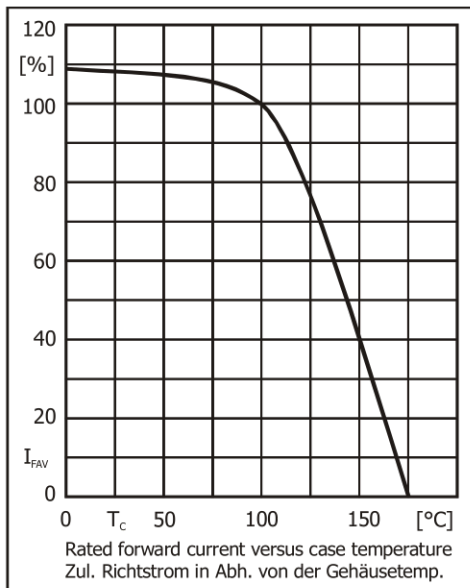

Disclaimer: See data book page 2 or [website](#)
Haftungsschluss: Siehe Datenbuch Seite 2 oder [Internet](#)

1 Temperature measured at the metallic base – Temperatur am Metallsockel gemessen