

<b>SBX2040-3G, SBX2045-3G</b> <b>Schottky Barrier Rectifier Diodes 3<sup>rd</sup> Generation</b> <b>Schottky-Gleichrichterdioden 3. Generation</b>	<b>I<sub>FAV</sub> = 20 A</b> <b>V<sub>F@5A</sub> &lt; 0.45 V</b> <b>T<sub>jmax</sub> = 150°C</b>	<b>V<sub>RRM</sub> = 40 V, 45 V</b> <b>I<sub>FSM</sub> = 290/330 A</b> <b>V<sub>F125</sub> ~ 0.25 V @ 5 A</b>
--	---	---

Version 2020-04-05

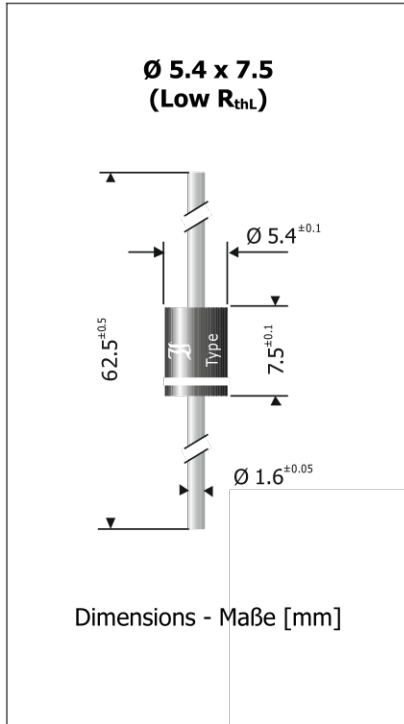

**Typical Applications**

Solar Bypass Diodes, Polarity Protection, Free-wheeling diodes, Output Rectification in DC/DC Converters  
Commercial grade <sup>1)</sup>

**Features**

Best trade-off between V<sub>F</sub> and I<sub>R</sub> <sup>2)</sup>  
 Lowest value R<sub>thL</sub> for lowest T<sub>j</sub>  
 Low forward voltage drop  
 Smaller package outline than SBX2040/45  
 Compliant to RoHS, REACH, Conflict Minerals <sup>1)</sup>



**Mechanical Data <sup>1)</sup>**

Taped in ammo pack	500
On request: on 13" reel	1000
Weight approx.	2 g
Case material	UL 94V-0
Solder & assembly conditions	260°C/10s MSL N/A

**Typische Anwendungen**

Solar-Bypassdioden, Verpolschutz, Freilaufdioden, Ausgangsgerichtung in Gleichstromwandlern  
Standardausführung <sup>1)</sup>

**Besonderheiten**

Optimale Auswahl von V<sub>F</sub> und I<sub>R</sub> <sup>2)</sup>  
 Niedrigster R<sub>thL</sub> Wert für niedrigstes T<sub>j</sub>  
 Niedrige Fluss-Spannung  
 Gehäusegröße kleiner als SBX2040/45  
 Konform zu RoHS, REACH, Konfliktmineralien <sup>1)</sup>

**Mechanische Daten <sup>1)</sup>**

Gegurtet in Ammo-Pack	
Auf Anfrage: auf 13" Rolle	
Gewicht ca.	
Gehäusematerial	
Löt- und Einbaubedingungen	

**Maximum ratings <sup>3)</sup>**

Type Typ	Repetitive peak reverse voltage Periodische Spitzensperrspannung V <sub>RRM</sub> [V]	Surge peak reverse voltage Stoßspitzensperrspannung V <sub>RSM</sub> [V]
SBX2040-3G	40	40
SBX2045-3G/-Q	45	45

**Grenzwerte <sup>3)</sup>**

Max. average forward rectified current, R-load Dauergrenzstrom in Einwegschaltung mit R-Last	T <sub>A</sub> = 50°C	I <sub>FAV</sub>	20 A <sup>4)</sup>
Peak forward surge current, Stoßstrom in Fluss-Richtung	Half sine-wave Sinus-Halbwelle	50 Hz (10 ms) 60 Hz (8.3 ms)	I <sub>FSM</sub> 290 A 330 A
Rating for fusing, t < 10 ms Grenzlastintegral, t < 10 ms		i <sup>2</sup> t	480 A <sup>2</sup> s
Junction temperature – Sperrschichttemperatur in DC forward mode – bei Gleichstrom-Durchlassbetrieb		T <sub>j</sub> T <sub>j</sub>	-50...+150°C ≤ 200°C <sup>2,5)</sup>
Storage temperature Lagerungstemperatur		T <sub>s</sub>	-50...+175°C

1 Please note the [detailed information on our website](#) or at the beginning of the data book  
 Bitte beachten Sie die [detaillierten Hinweise auf unserer Internetseite](#) bzw. am Anfang des Datenbuches  
 2 For more details, ask for the Diotec Application Note "Reliability of Bypass Diodes"  
 Weitere Infos in der Diotec Applikationsschrift „Reliability of Bypass Diodes“  
 3 T<sub>A</sub> = 25°C unless otherwise specified – T<sub>A</sub> = 25°C wenn nicht anders angegeben  
 4 Valid, if leads are kept at ambient temperature at a distance of 10 mm from case  
 Gültig, wenn die Anschlussdrähte in 10 mm Abstand vom Gehäuse auf Umgebungstemperatur gehalten werden  
 5 Meets the Requirements of IEC 61215 bypass diode thermal test  
 Erfüllt die Anforderungen des IEC 61215 Bypass-Diodentests

**Characteristics**
**Kennwerte**

Type Typ	Forward voltage Durchlass-Spannung			Forward voltage Durchlass-Spannung			Forward voltage Durchlass-Spannung		
	$V_F$ [V]	@ $I_F$ [A]	@ $T_j$	$V_F$ [V]	@ $I_F$ [A]	@ $T_j$	$V_F$ [V]	@ $I_F$ [A]	@ $T_j$
SBX2040-3G SBX2045-3G/-Q	typ. 0.25	5	125°C	< 0.45	5	25°C	< 0.53	20	25°C

Leakage current Sperrstrom	SBX2040-3G	$T_j = 25^\circ\text{C}$ $T_j = 100^\circ\text{C}$	$V_R = V_{RRM}$	$I_R$	< 60 $\mu\text{A}$ typ. 10 mA
Leakage current Sperrstrom	SBX2045-3G	$T_j = 25^\circ\text{C}$ $T_j = 100^\circ\text{C}$	$V_R = V_{RRM}$	$I_R$	< 100 $\mu\text{A}$ typ. 15 mA
Typical junction capacitance – Typische Sperrschichtkapazität			$V_R = 4\text{ V}$	$C_j$	720 pF
Typical thermal resistance junction to ambient Typischer Wärmewiderstand Sperrschicht – Umgebung				$R_{thA}$	10 K/W <sup>1)</sup>
Typical thermal resistance junction to lead (at the case) Typischer Wärmewiderstand Sperrschicht-Anschlussdraht (am Gehäuse)				$R_{thL}$	2.1 K/W <sup>2)</sup>

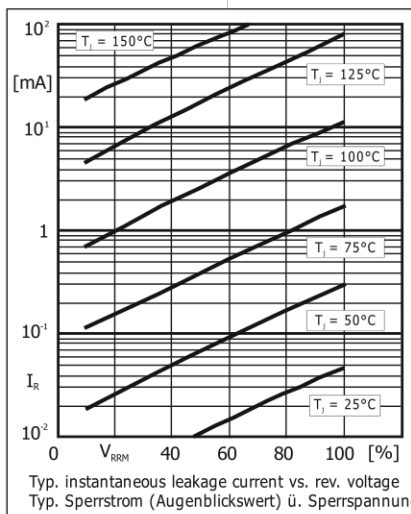
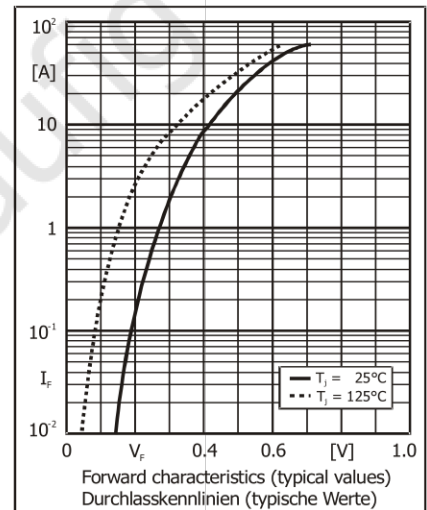
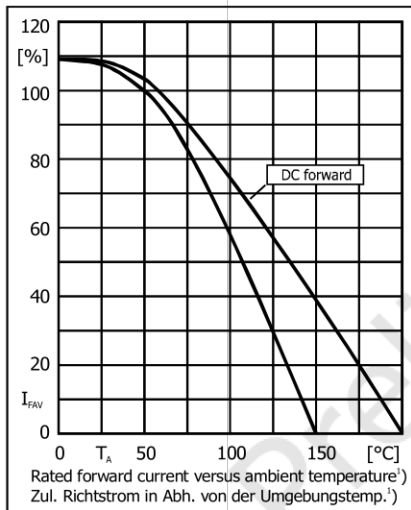

**Disclaimer:** See data book page 2 or [website](#)  
**Haftungsschluss:** Siehe Datenbuch Seite 2 oder [Internet](#)

- Valid, if leads are kept at ambient temperature at a distance of 10 mm from case  
Gültig, wenn die Anschlussdrähte in 10 mm Abstand vom Gehäuse auf Umgebungstemperatur gehalten werden
- Valid, if leads are kept at ambient temperature at a distance of 3 mm from case  
Gültig, wenn die Anschlussdrähte in 3 mm Abstand vom Gehäuse auf Umgebungstemperatur gehalten werden