

# DIP SWITCH DHA SERIES

2.2mm  
Half Pitch Type

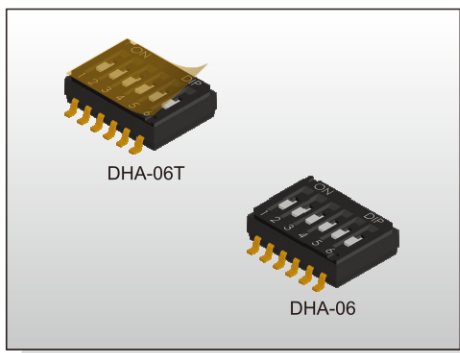

DIP SWITCH



## FEATURES

- ※Low profile 2.2mm height
- ※Gold contact for high reliability
- ※Top tape type for washing process

## APPLICATION

- ※Industrial control
- ※Automatic machines control
- ※NB, electronic devices

## SPECIFICATION

Contact Rating	25mA, 24V DC
Contact Resistance	100mΩ max.
Insulation Resistance	100MΩ min. 500V DC
Dielectric Strength	300V AC/1 minute
Operating Force	500gf max.
Travel	0.8mm
Operating Life	1,000 cycles
Operating Temp.	-40°C ~ +85°C
Storage Temp.	-40°C ~ +85°C

## CIRCUIT

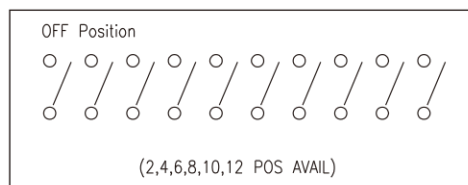

## HOW TO ORDER

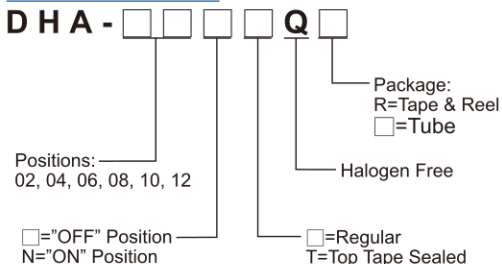

## PACKAGE

<Tape & Reel>  
1800 pcs

<Tube>  
DHA-02: 125 pcs  
DHA-04: 75 pcs  
DHA-06: 54 pcs  
DHA-08: 40 pcs  
DHA-10: 33 pcs  
DHA-12: 28 pcs

## DHA

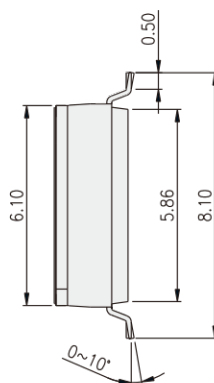
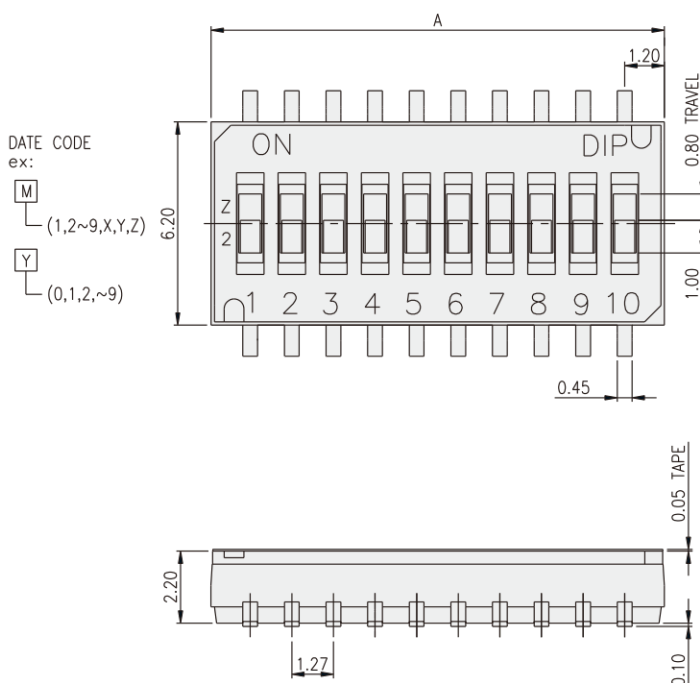

PART NO.	NO.OF POS	DIM A
DHA-02	2	3.67
DHA-04	4	6.21
DHA-06	6	8.75
DHA-08	8	11.29
DHA-10	10	13.83
DHA-12	12	16.37

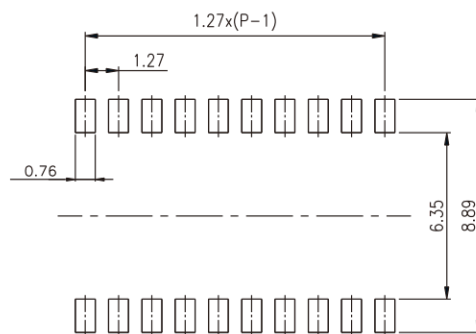

P.C.B. LAYOUT