

MINIATURE SURFACE MOUNT RELAY

For automotive applications

1 POLE - 25A

FTR-P6 Series

■ FEATURES

- Surface mount relays for automotive applications
- Miniature size (67% of the volume of FTR-P3 relays)
- High contact capacity with proven contact material (100,000 operations, 14V, 25A)
- Low coil power dissipation (800mW nominal achieved with state-of-the-art magnetic design)
- Semi low noise (average acoustic noise level: 60dB distance 5cm)
- Application examples: Power window, door lock, power seat, sunroof, wiper
- RoHS compliant

Please see page 7 for more information



■ Part Numbers

[Example]	FTR-P6	G	N	012	WA	**
	(a)	(b)	(c)	(d)	(e)	(f)

(a)	Relay type	FTR-P6 : FTR-P6 series
(b)	Contact configuration	G : 1 form C
(c)	Contact gap	N : 0.25mm gap
(d)	Contact rated voltage	012 : 10..... 12VDC Coil rating table at page 3
(e)	Contact material	WA : Silver-tin oxide indium
(f)	Special type	None : Standard package DP : Dry package Others : To be assigned custom specification

Actual marking does not carry the type name: "FTR"

E.g.: Ordering code: FTR-P6GN012WA Actual marking: P6GN012WA

FTR-P6 Series

■ Specifications

Item			FTR-P6	Remarks / conditions
Contact data	Configuration		1 form C	
	Material		Silver-tin oxide	
	Voltage drop		Max. 100 mV	At 1A, 12VDC (resistance)
	Contact rating		25A, 14VDC	Motor locked
	Max. carrying current		25A / 1h	25°C, nominal voltage applied to coil
	Max. inrush current		35A	
	Min. switching load *		1A, 6VDC	Reference
Coil	Coil power consumption		Approx. 0.8W	At rated coil voltage
	Operating temperature range		-40°C ~ +85°C	No frost
	Storage temperature range		-40°C ~ +100°C	No frost
	Operating humidity		45 to 85% RH	
Timing data	Operate		Max. 10ms	
	Release		Max. 5ms	
Life	Mechanical		Min. 1×10^6 operations	
	Electrical		Min. 100×10^3 operations	14VDC, 25A locked motor
Insulation	Insulation resistance		Min. 100MΩ at 500VDC	Initial
	Dielectric withstanding voltage	Open contacts	500VAC (50/60Hz), 1 minute	
		Coil contact	500VAC (50/60Hz), 1 minute	
Other	Vibration resistance	Misoperation	10 to 200Hz, 44m/s ² (4.5G), constant acceleration	
		Endurance	10 to 200Hz, 44m/s ² (4.5G), constant acceleration	
	Shock resistance	Misoperation	Min. 100m/s ² (11 ± 1ms)	
		Endurance	Min. 1,000m/s ² (6 ± 1ms)	
	Dimensions / weight		9.0 x 12.0 x 10.3 mm / approx. 3.3g	

*: Minimum switching loads mentioned above are reference values. Please perform the confirmation test with actual load before production since reference values may vary according to switching frequencies, environmental conditions and expected reliability levels.

Note: Care shall be taken on the heat generated on PC board when maximum carrying current exceeds 10A. Please perform the confirmation test with actual conditions.

FTR-P6 Series

■ Coil Data

Coil code	Rated Coil Voltage (VDC)	Coil Resistance +/-10% (Ω)	Must Operate Voltage* (VDC)	Must Release Voltage* (VDC)
010	10	125	6.5 (at 20°C) 8.2 (at 85°C)	0.8 (at 20°C) 1.0 (at 85°C)
012	12	180	7.3 (at 20°C) 9.2 (at 85°C)	1.0 (at 20°C) 1.3 (at 85°C)

Note: All values in the table are valid at 20°C and zero contact current, unless otherwise specified.

*: Specified operated values are valid for pulse wave voltage.

■ Dimensions

- Dimensions

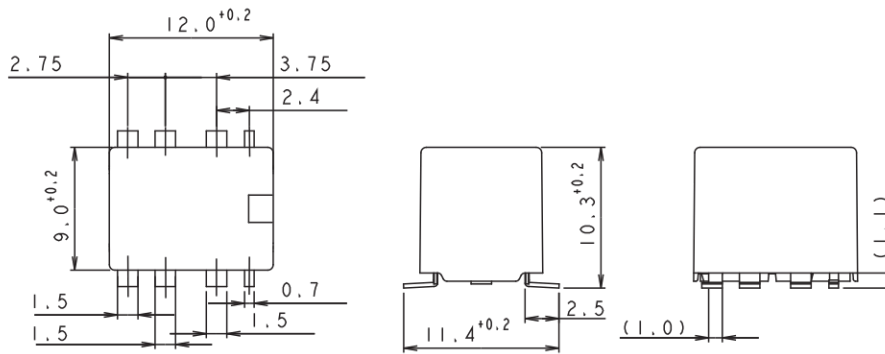

*Dimensions of the terminals do not include thickness of pre-solder.

- Schematics (TOP VIEW)

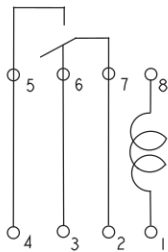

- PC Board Mounting Hole Layout (TOP VIEW)

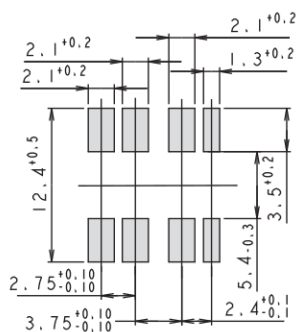

(): Reference value
Unit: mm

FTR-P6 Series

■ Packaging

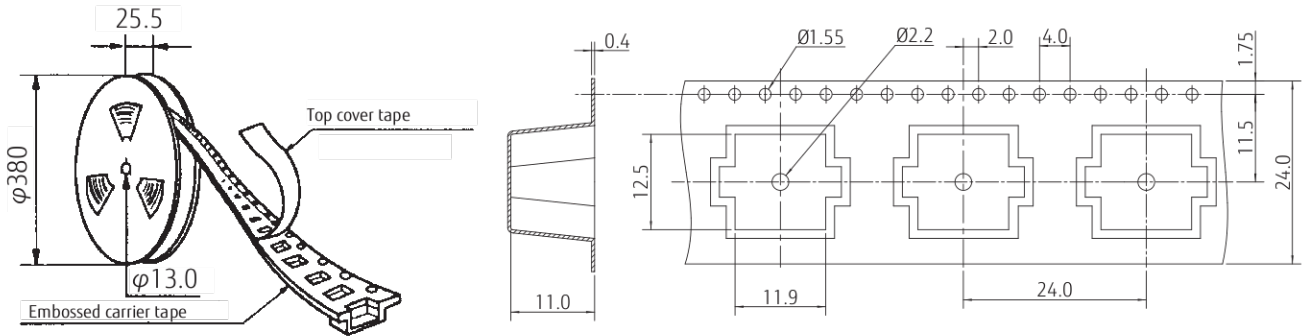

■ Characteristic Data (Reference)

Life test (example)

- Test condition
25A 16VDC
motor lock
100,000 operations min.
0.5 sec. ON, 5.5 sec. OFF

- Test circuit

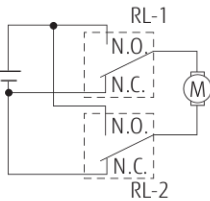

- Current wave form

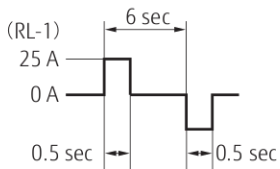

- Operate / release voltage

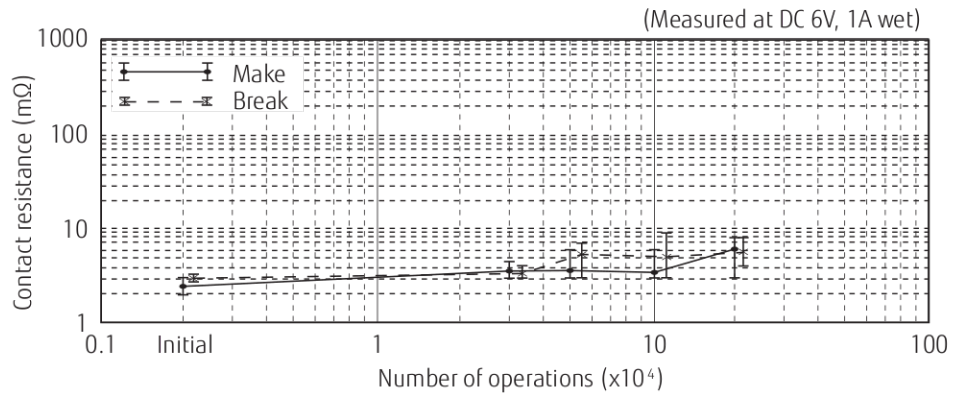
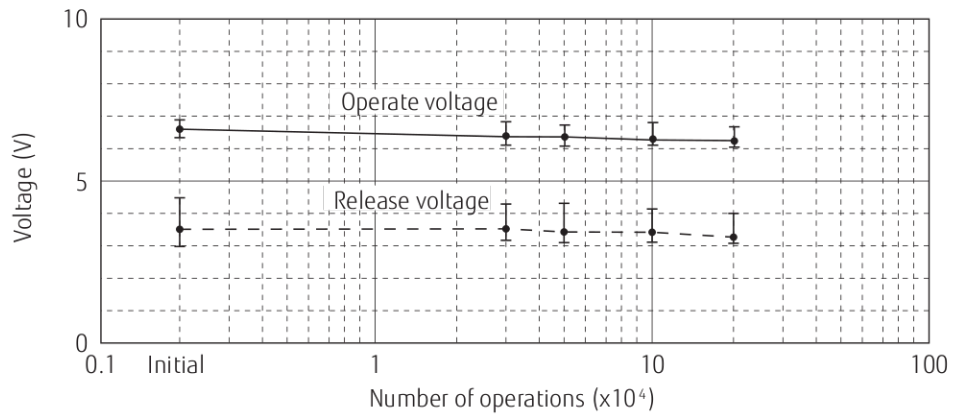

FTR-P6 Series

- Test condition
Inrush current 20A, 16VDC
motor free
400,000 operations min.
1.5 sec. ON, 2.0 sec. OFF

- Test circuit

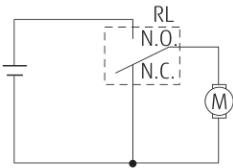

- Current wave form

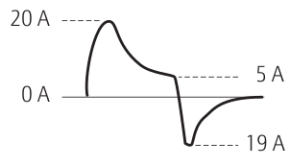

- Operate / release voltage

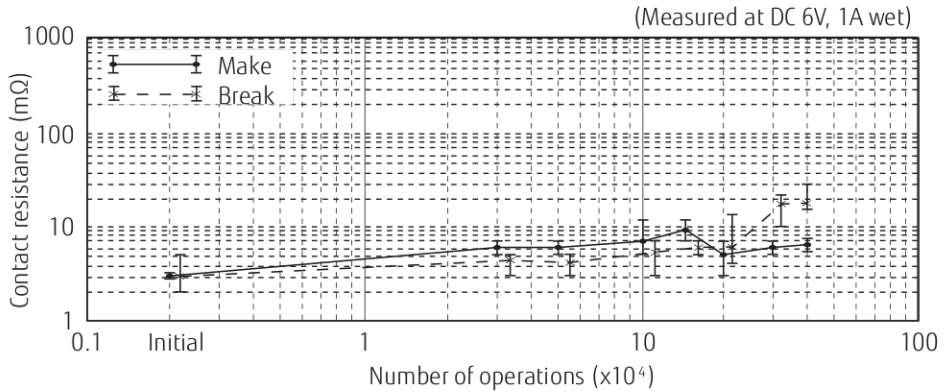
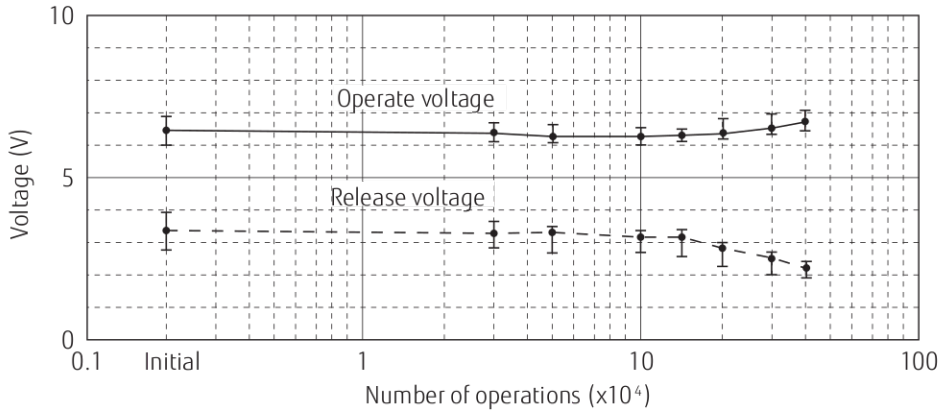

Coil temperature rise

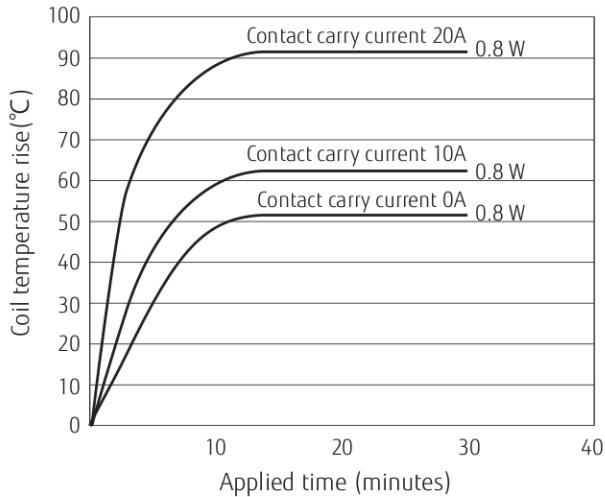

Operating coil voltage range
(FTR-P6GN012WA)

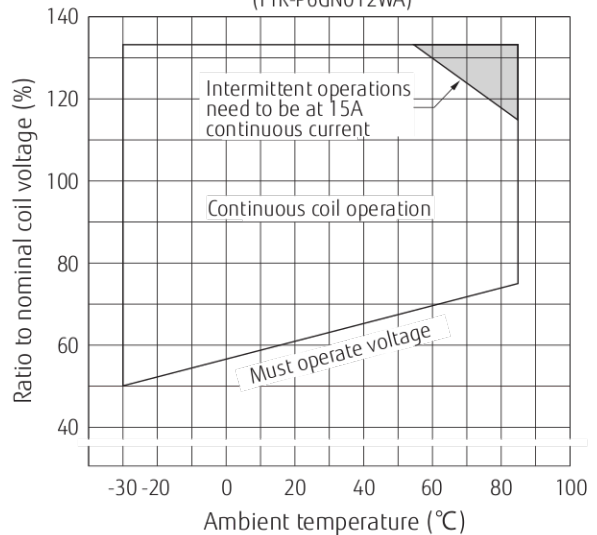

FTR-P6 Series

Vibration resistance characteristics

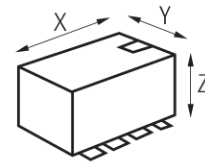
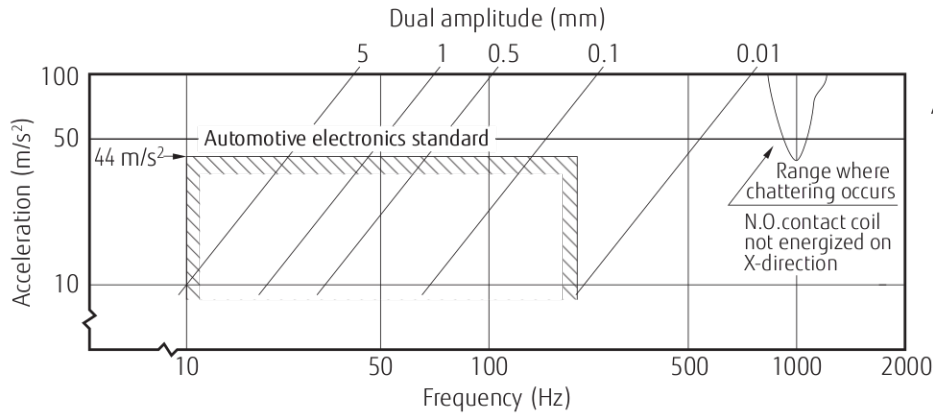

Shock resistance characteristics

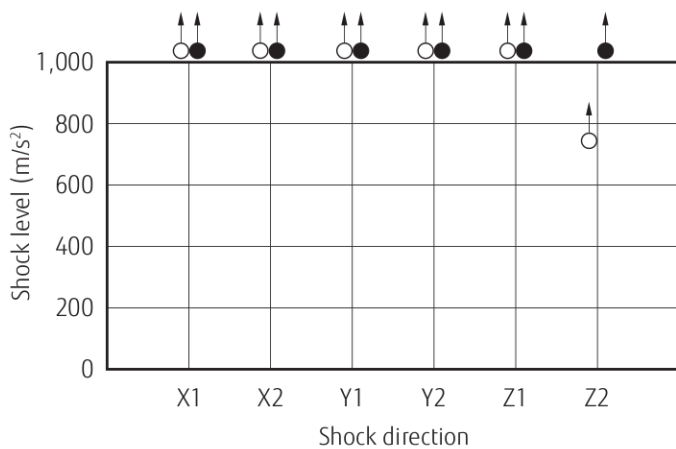

Shock application time: 6±1ms, half-sine wave
 Test condition: Coil energized and de-energized
 Shock direction: See diagram below
 Direction level: chatter > 1ms

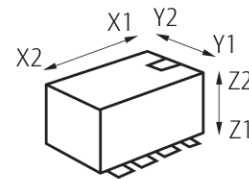

○ : Break contact (coil de-energized)
 ● : Make contact (coil energized)

Distribution of operate/release voltage

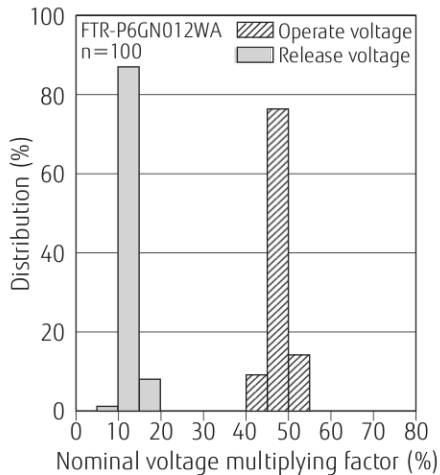

Distribution of operate/release time

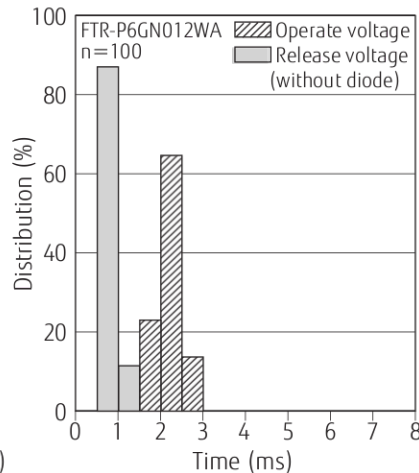

Distribution of contact resistance

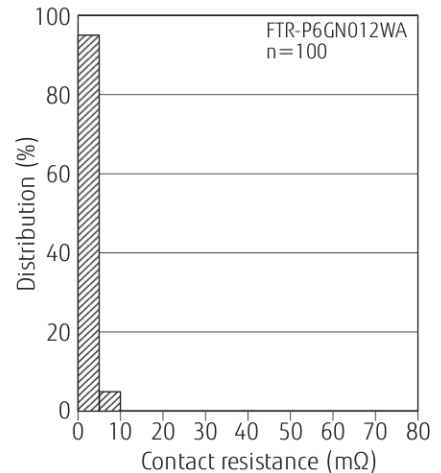

FTR-P6 Series

GENERAL INFORMATION

1. ROHS Compliance

- All relays produced by Fujitsu Components are compliant with RoHS directive 2011/65/EU including amendments.
- Use of Cadmium in electrical contacts is exempted as per Annex III of the RoHS directive 2001/65/EU. Please consider expiry date of exemption. Relays with Cadmium containing contacts are not to be used for new designs.
- All relays are lead-free. Please refer to Lead-Free Status Info for older date codes at: <http://www.fujitsu.com/downloads/MICRO/fcai/relays/lead-free-letter.pdf>
- Characteristic data is not guaranteed values, but measured values of samples from production line.

2. Recommended lead free solder condition

- Lead free solder plating on relay terminals is Sn-3.0Ag-0.5Cu, unless otherwise specified. This material has been verified to be compatible with PbSn assembly process.
- Recommended solder for assembly: Sn-3.0Ag-0.5Cu.

Solder by Soldering Iron:

Soldering Iron 30-60W

Temperature: maximum 340-360°C

Duration: maximum 3 sec.

Reflow Solder Condition:

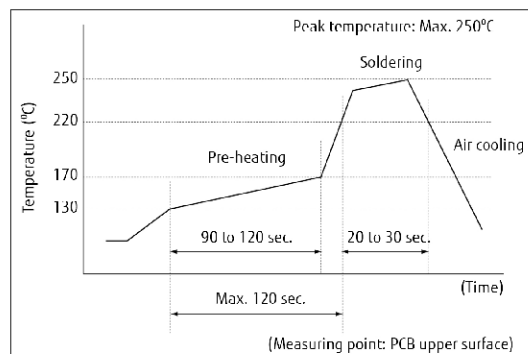

We highly recommend that you confirm your actual solder conditions

3. Moisture Sensitivity

- Moisture Sensitivity Level standard is not applicable to electromechanical relays, unless otherwise indicated. -DP relay will be shipped in moisture barrier bag.

4. Tin Whiskers

- Dipped SnAgCu solder is known as presenting a low risk to tin whisker development. No considerable length whisker was found by our in house test.

FTR-P6 Series

Fujitsu Components International Headquarter Offices

Japan FUJITSU COMPONENT LIMITED Shinagawa Seaside Park Tower 19F, 12-4, Higashi-shinagawa 4-chome, Shinagawa-ku, Tokyo, 140-0002, Japan Tel: (81-3) 3450-1682 Fax: (81-3) 3474-2385 Email: fcl-contact@cs.jp.fujitsu.com Web: www.fujitsu.com/jp/fcl/	Asia Pacific FUJITSU COMPONENTS ASIA, LTD. 102E Pasir Panjang Road #01-01 Citilink Warehouse Complex Singapore 118529 Tel: (65) 6375-8560 Fax: (65) 6273-3021 Email: fcal@sg.fujitsu.com Web: www.fujitsu.com/sg/products/devices/components	Korea FUJITSU COMPONENTS KOREA LIMITED Alpha Tower #403, 645 Samsyeong-dong, Bundang-gu, Seongnam-si, Gyeonggi-do, 13524 Korea Tel: (82) 31-708-7108 Fax: (82) 31-709-7108 Email: fcal@sg.fujitsu.com www.fujitsu.com/sg/products/devices/components/
North and South America FUJITSU COMPONENTS AMERICA, INC 2290 North First Street, Suite 212 San Jose, CA 95131, USA Tel: (1-408) 745-4900 Fax: (1-408) 745-4970 Email: components@us.fujitsu.com Web: us.fujitsu.com/components	China FUJITSU ELECTRONIC COMPONENTS (SHANGHAI) CO., LTD. Unit 4306, InterContinental Center 100 Yu Tong Road, Shanghai 200070, China Tel: (86-21) 3253 0998 Fax: (86-21) 3253 0997 Email: fcal@sg.fujitsu.com Web: www.fujitsu.com/sg/products/devices/components	
Europe FUJITSU COMPONENTS EUROPE B.V. Diamantlaan 25 2132 WV Hoofddorp Netherlands Tel: (31-23) 5560910 Fax: (31-23) 5560950 Email: info@fceu.fujitsu.com Web: www.fujitsu.com/uk/components	Hong Kong FUJITSU COMPONENTS HONG KONG CO., LTD Unit 506, Inter-Continental Plaza No.94 Granville Road, Tsim Sha Tsui, Kowloon, Hong Kong Tel: (852) 2881-8495 Tex: (852) 2894-9512 Email: fcal@sg.fujitsu.com Web: www.fujitsu.com/sg/products/devices/components/	

©2017 Fujitsu Components Europe B.V. All rights reserved. All trademarks or registered trademarks are the property of their respective owners.

The contents, data and information in this datasheet are provided by Fujitsu Component Ltd. as a service only to its user and only for general information purposes.

The use of the contents, data and information provided in this datasheet is at the users' own risk.

Fujitsu has assembled this datasheet with care and will endeavor to keep the contents, data and information correct, accurate, comprehensive, complete and up to date.

Fujitsu Components Europe B.V. and affiliated companies do however not accept any responsibility or liability on their behalf, nor on behalf of its employees, for any loss or damage, direct, indirect or consequential, with respect to this datasheet, its contents, data, and information and related graphics and the correctness, reliability, accuracy, comprehensiveness, usefulness, availability and completeness thereof.

Nor do Fujitsu Components Europe B.V. and affiliated companies accept on their behalf, nor on behalf of its employees, any responsibility or liability for any representation or warrant of any kind, express or implied, including warranties of any kind for merchantability or fitness for particular use, with respect to these datasheets, its contents, data, information and related graphics and the correctness, reliability, accuracy, comprehensiveness, usefulness, availability and completeness thereof. Rev. March 16th, 2017