

Extrusion

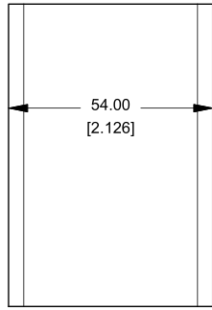

Slot Details

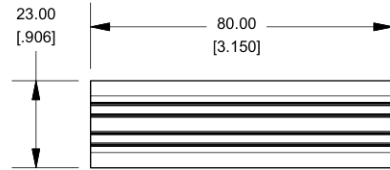
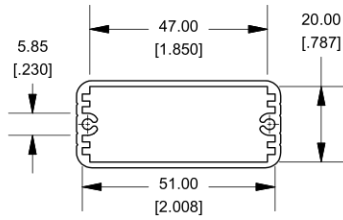
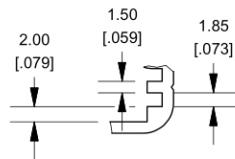

End Plate

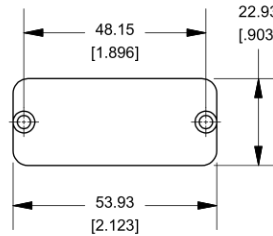

1455C801

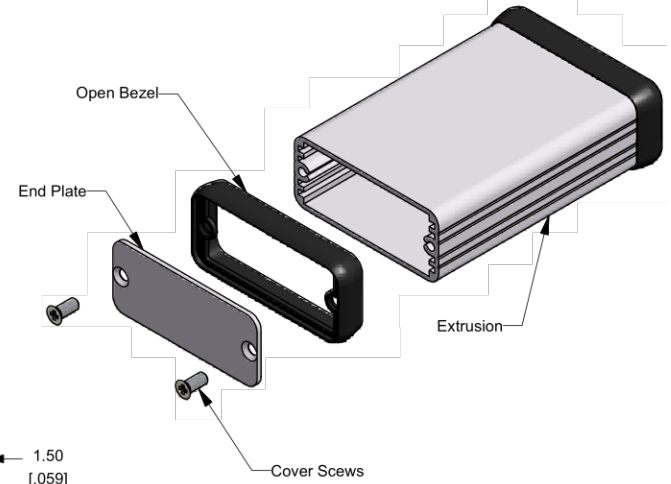

Open Bezel

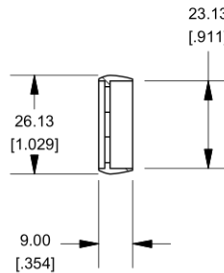
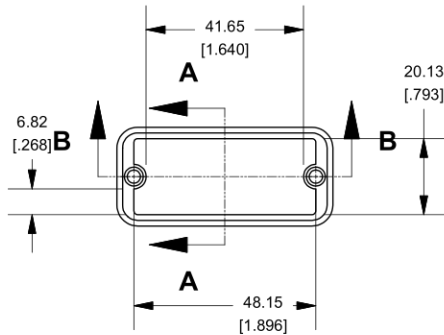

SECTION A-A
SCALE 1 / 2

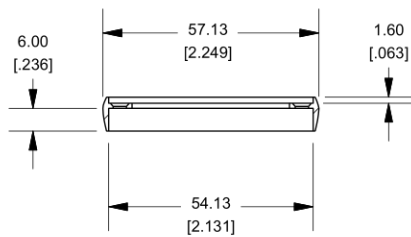

SECTION B-B
SCALE 1 / 2

Note	
Purchased assembly includes box, belly plate, choice of bezel, cover screws and self adhesive rubber feet. Box made from Extruded Aluminum 6063.	
PART NUMBERS	
1455C801 Open Bezel with Aluminum End Plate	
Clear Anodized	1455C801
Black Anodized	1455C801BK
ACCESSORIES	
Cover Screws (Pkg 100)	1455MS100
#6 Self Tapping Nickel Plated Screws	1455MS100BK
Black Cover Screws (Pkg 100)	1455MS100BK
#6 Self Tapping Nickel Plated Screws	1455MS100BK
Aluminum End Plates (Pkg 10)	1455CAL-10
Black Anodized Aluminum End Plates (Pkg 10)	1455CALBK-10
Open Plastic Bezels, Black (Pkg 10)	1455CBBK-10



www.hammondmfg.com