

Features

- High noise immunity CMOS technology
- Operating voltage: 10V
- Line frequency: 60Hz or 50Hz.
- High sensitivity and stability
- Polarity insensitive with AC line
- Loading range of sense input from 0 to 1200pf
- Minimum peripheral components

General Description

The HT7712B/HT7713B is a CMOS fabricated LSI chip in an 8-lead DIP package. It is designed to control the brightness of lamps by changing the firing angles of the TRIAC through a touch sensitive input. The chip can be used either as a 3-step or a switch function dimmer. The high sensitivity and stability of the HT7712B/HT7713B ensure its high performance. The touch sensitive input can sustain very heavy capacitive loading and propagate

sense through a highly resistive line. The application circuit of the HT7712B/HT7713B is very simple.

Of these two chips, the HT7713B is a 3-step dimmer controller whose trigger angles are set at 17°, 86°, 121° — where 17° is the brightest, 86° the medium brightness, and 121° the darkest. The HT7712B, on the other hand, is an ON/OFF switch whose ON state is set at an angle of 17°.

Pin Assignment

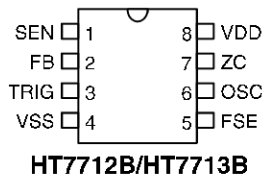

Block Diagram

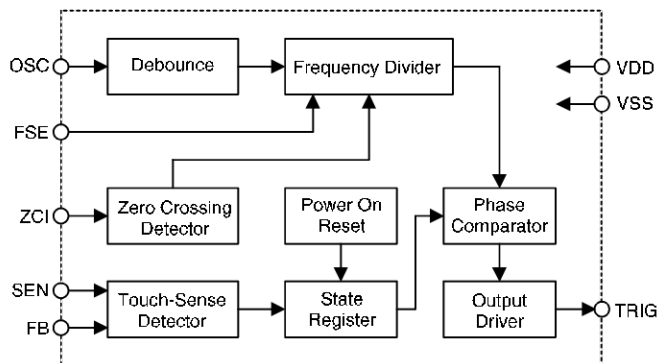

Pad Coordinates

Unit : mil

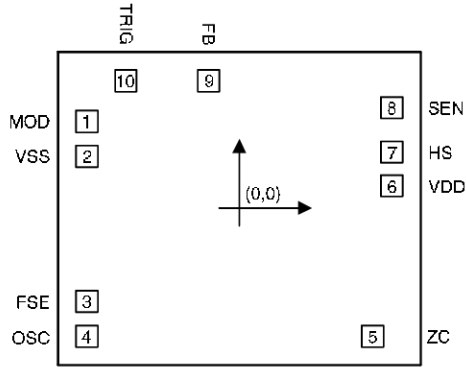

Pad No.	X	Y	Pad No.	X	Y
1	-35.33	20.07	6	35.24	5.13
2	-35.33	11.97	7	35.24	12.96
3	-35.33	-21.60	8	35.24	23.22
4	-35.33	-29.70	9	-7.16	29.43
5	30.83	-29.70	10	-26.33	29.43

 Chip size: 85 × 73 (mil)²

* The IC substrate should be connected to VDD in the PCB layout artwork.

Pin Description

Pin No.	Pin Name	Description
1	SEN	Touch sense input
2	FB	Feedback signal to control the sink current of SEN pin
3	TRIG	Trigger output to drive the TRIAC
4	VSS	Negative power terminal
5	FSE	Line frequency selection (floating: 60Hz ; Vss: 50Hz)
6	OSC	Oscillator input
7	ZC	Line frequency 60Hz or 50Hz input for zero crossing
8	VDD	Positive power terminal

Absolute Maximum Rating

Supply Voltage..... -0.3V to 13V

Storage Temp -50°C to 125°C

 Input Voltage..... V_{SS}-0.3V to V_{DD}+0.3V

Operating Temp 0° to 70°C

Electrical Characteristics

(Ta=25°C)

Symbol	Parameter	Test Condition		Min.	Max.	Unit
		V _{DD}	Condition			
V _{DD}	Dc Supply Voltage	—	—	9	11	V
I _{OL}	Trig Sink Current	10V	V _{OL} =2V	30	—	mA
I _{OH}	Trig Drive Current	10V	V _{OH} =5V	-1	—	mA
I _{LEAK}	I/P Leakage Current	10V	—	—	0.5	μA

Typical Application Circuit

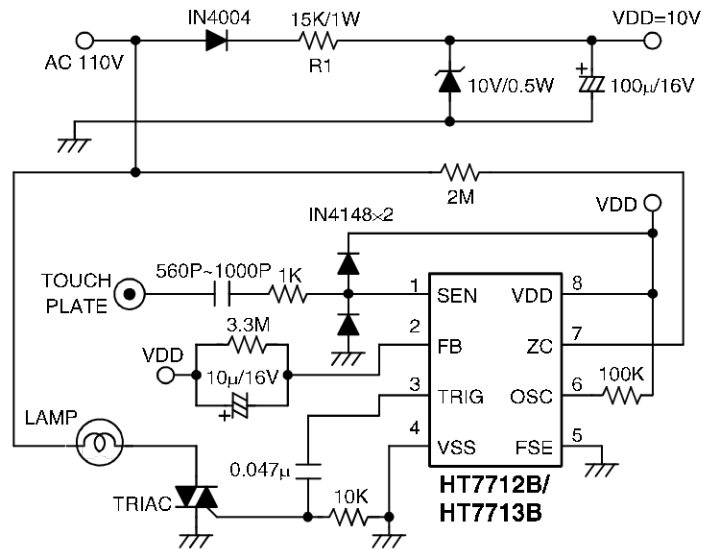

- Note: 1. In 220V AC line power, the R1=33K/1W
 2. In 60Hz line frequency, the pin FSE=Floating
 In 50Hz line frequency, the pin FSE=VSS