

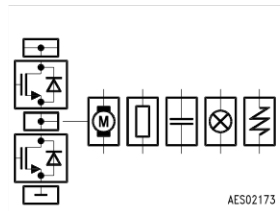

1 Overview

1.1 Features

- Six High-Side and six Low-Side-Drivers
- Free configurable as switch, halfbridge or H-bridge
- Optimized for DC motor management applications
- 0.6 A continuous (1 A peak) current per switch
- $R_{DS\ ON}$: typ. 0.8 Ω , @ 25 °C per switch
- Outputs fully short circuit protected with diagnosis
- Overtemperature-Protection with hysteresis and diagnosis
- Temperature prewarning
- Standard SPI-Interface
- Very low current consumption (typ. 10 μ A, @ 25 °C) in stand-by (Inhibit) mode
- Over- and Undervoltage-Lockout
- CMOS/TTL compatible inputs with hysteresis
- Internal clamp diodes
- Enhanced power P-DSO-Package
- Green Product (RoHS compliant)
- AEC Qualified



Type	Package
TLE 6208-6 G	PG-DSO-28-41

Functional Description

The TLE 6208-6 G is a fully protected **Hex-Half-Bridge-Driver** designed specifically for automotive and industrial motion control applications. The part is based on Infineons Smart Power Technology SPT® which allows bipolar and CMOS control circuitry in accordance with DMOS power devices existing on the same monolithic circuitry. The six low and high side drivers are freely configurable and can be controlled separately. Therefore all kind of loads can be combined. In motion control up to 5 actuators (DC-Motors) can be connected to the 6 halfbridge-outputs (cascade configuration). Operation modes forward (cw), reverse (ccw), brake and high impedance are controlled from a standard SPI-Interface. The possibility to control the outputs via software from a central logic, allows limiting the power dissipation. So the standard PG-DSO-28-41-package meets the application requirements and saves PCB-Board-space and cost.

Furthermore the build-in features like Over- and Undervoltage-Lockout, Over-Temperature-Protection and the very low quiescent current in stand-by mode opens a wide range of automotive- and industrial-applications.

1.2 Pin Configuration (top view)

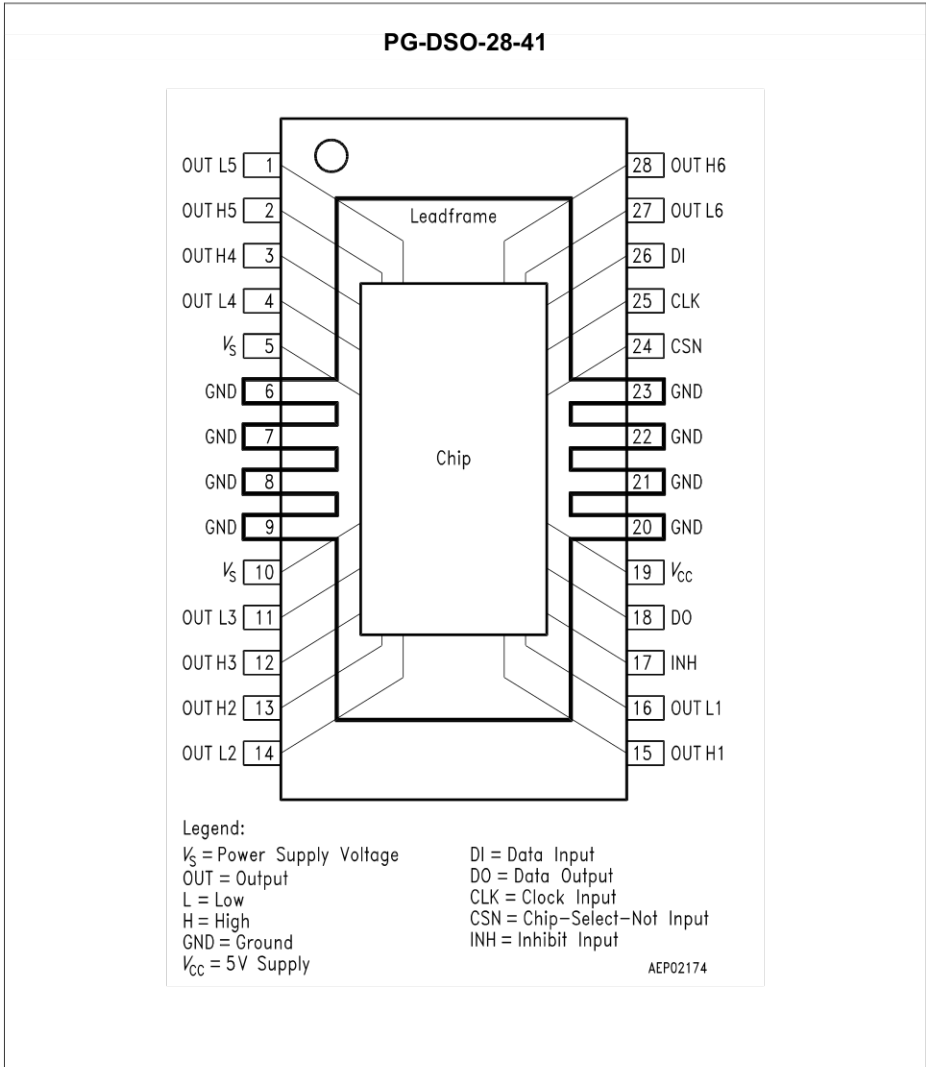

Figure 1

1.3 Pin Definitions and Functions

Pin No.	Symbol	Function
1	OUTL5	Low-Side-Output 5 ; Power-MOS open drain with internal reverse diode; no internal clamp diode or active zenering; short circuit protected and open load controlled.
2	OUTH5	High-Side-Output 5 ; Power-MOS open source with internal reverse diode; no internal clamp diode or active zenering; short circuit protected and open load controlled.
3	OUTH4	High-Side-Output 4 ; see pin2.
4	OUTL4	Low-Side-Output 4 ; see pin1.
5	V_s	Power supply ; external connection to pin 10 necessary; needs a blocking capacitor as close as possible to GND Value: 22 μ F electrolytic in parallel to 220 nF ceramic.
6, 7, 8, 9	GND	Ground ; Reference potential; internal connection to pin 20, 21, 22 and 23; cooling tab; to reduce thermal resistance; place cooling areas on PCB close to this pins.
10	V_s	Power Supply ; see pin 5.
11	OUTL3	Low-Side-Output 3 ; see pin1.
12	OUTH3	High-Side-Output 3 ; see pin2.
13	OUTH2	High-Side-Output 2 ; see pin2.
14	OUTL2	Low-Side-Output 2 ; see pin1.
15	OUTH1	High-Side-Output 1 ; see pin2.
16	OUTL1	Low-Side-Output 1 ; see pin1.
17	INH	Inhibit input ; has an internal pull down; device is switched in standby condition by pulling the INH terminal low.
18	DO	Serial-Data-Output ; this 3-state output transfers diagnosis data to the control device; the output will remain 3-stated unless the device is selected by a low on Chip-Select-Not (CSN); see Table 2 for Diagnosis protocol.
19	V_{cc}	Logic supply voltage ; needs a blocking capacitor as close as possible to GND; Value: 10 μ F electrolytic in parallel to 220 nF ceramic.

1.3 Pin Definitions and Functions (cont'd)

Pin No.	Symbol	Function
20, 21, 22, 23	GND	Ground
24	CSN	Chip-Select-Not input; CSN is an active low input; serial communication is enabled by pulling the CSN terminal low; CSN input should only be transitioned when CLK is low; CSN has an internal active pull up and requires CMOS logic level inputs.
25	CLK	Serial clock input; clocks the shiftregister; CLK has an internal active pull down and requires CMOS logic level inputs.
26	DI	Serial data input; receives serial data from the control device; serial data transmitted to DI is an 16bit control word with the Least Significant Bit (LSB) being transferred first: the input has an active pull down and requires CMOS logic level inputs; DI will accept data on the falling edge of CLK-signal; see Table 1 for input data protocol.
27	OUTL6	Low-Side-Output 6; see pin1.
28	OUTH6	High-Side-Output 6; see pin2.

1.4 Functional Block Diagram

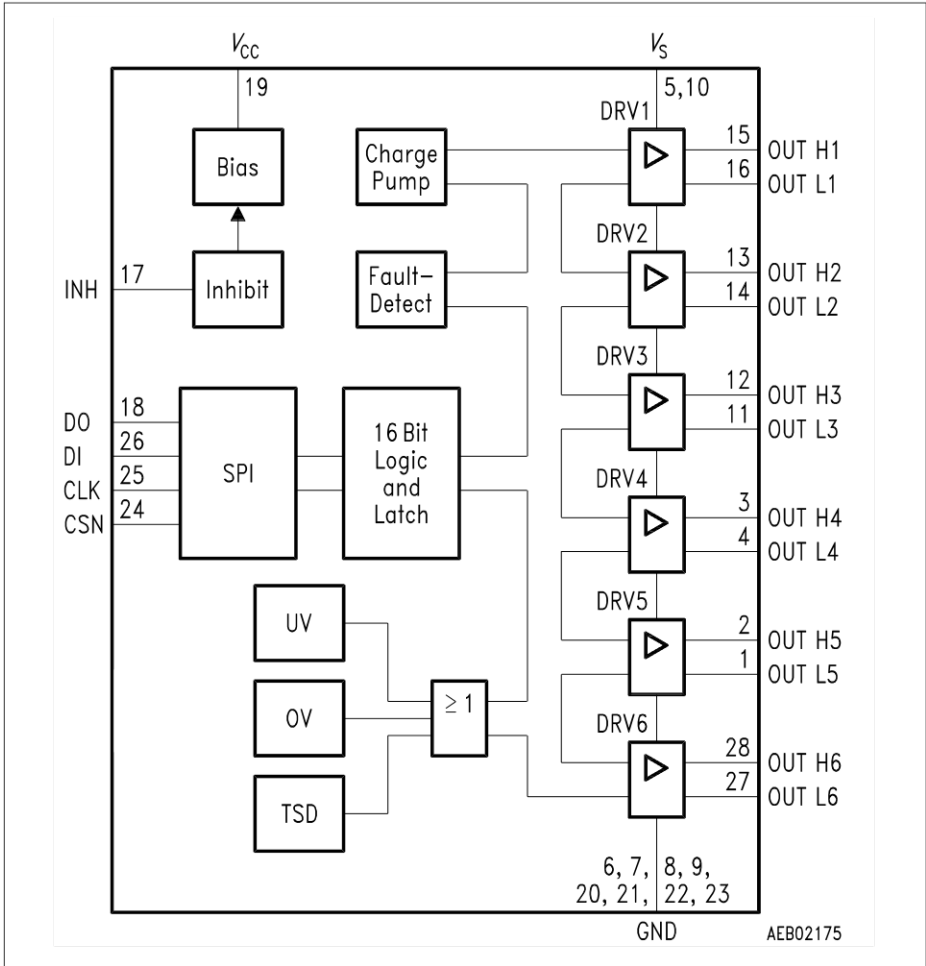

Figure 2
Block Diagram TLE 6208-6 G

1.5 Circuit Description

Figure 2 shows a block schematic diagram of the module.

There are 6 halfbridge drivers on the right-hand side. An HS driver and an LS driver are combined to form a halfbridge driver in each case.

The drivers communicate via the internal data bus with the logic and the other control and monitoring functions: undervoltage (UV), overvoltage (OV), overtemperature (TSD), charge pump and fault detect.

Two connection interfaces are provided for supply to the module: All power drivers are connected to the supply voltage V_S . These are monitored by overvoltage and undervoltage comparators with hysteresis, so that the correct function can be checked in the application at any time.

The logic is supplied by the V_{CC} voltage, typ. with 5 V. The V_{CC} voltage uses an internally generated Power-On Reset (POR) to initialize the module at power-on. The advantage of this system is that information stored in the logic remains intact in the event of short-term failures in the supply voltage V_S . The system can therefore continue to operate following V_S undervoltage, without having to be reprogrammed. The “undervoltage” information is stored, and can be read out via the interface. The same logically applies for overvoltage. “Interference spikes” on V_S are therefore effectively suppressed.

The situation is different in the case of undervoltage on the V_{CC} connection pin. If this occurs, then the internally stored data is deleted, and the output levels are switched to high-impedance status (tristate). The module is initialized by V_{CC} following restart (Power-On Reset = POR).

The 16-bit wide programming word or control word (see **Table 1**) is read in via the DI data input, and this is synchronized with the clock input CLK. The status word appears synchronously at the DO data output (see **Table 2**).

The transmission cycle begins when the chip is selected with the CSN input (H to L). If the CSN input changes from L to H then the word which has been read in becomes the control word. The DO output switches to tristate status at this point, thereby releasing the DO bus circuit for other uses.

The INH inhibit input can be used to cut off the complete module. This reduces the current consumption to just a few μA , and results in the loss of any data stored. The output levels are switched to tristate status. The module is reinitialized with the internally generated POR (Power-On Reset) at restart.

This feature allows the use of this module in battery-operated applications (vehicle body control applications).

Every driver block from DRV 1 to 6 contains a low-side driver and a high-side driver. The output connections have been selected so that each HS driver and LS driver pair can be combined to form a halfbridge by short-circuiting adjacent connections. The full flexibility of the configuration can be achieved by dissecting the halfbridges into “quarter-bridges”.

Table 3 shows examples of possible applications.

When commutating inductive loads, the dissipated power peak can be significantly reduced by activating the transistor located parallel to the internal freewheeling diode. A special, integrated “timer” for power ON/OFF times ensures there is no crossover current at the halfbridge.

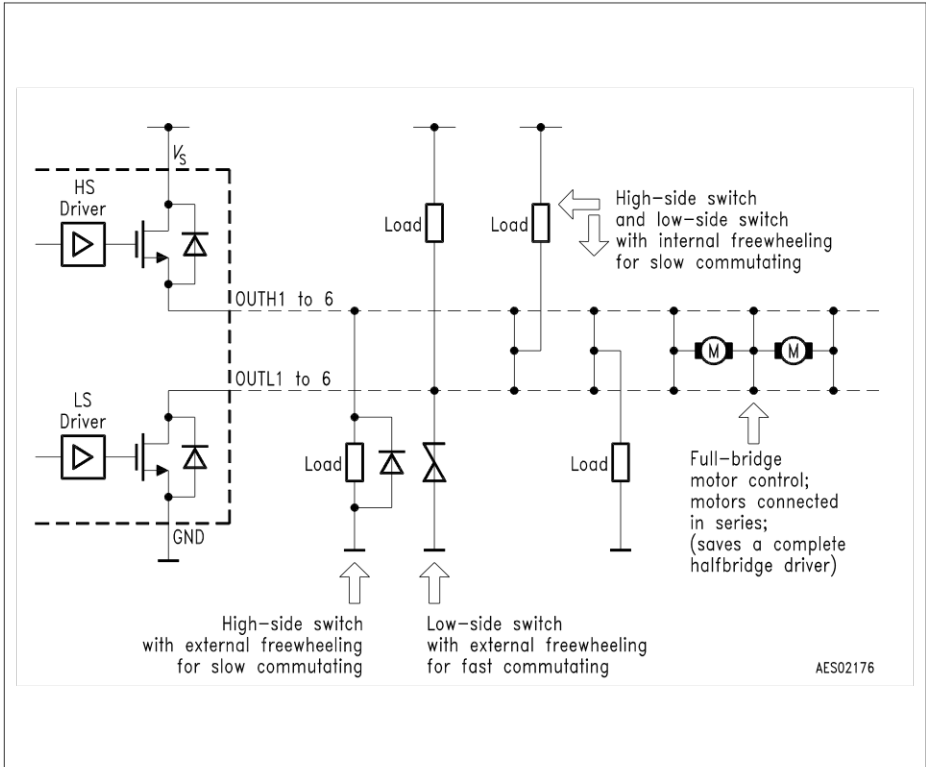

Figure 3
Configuration Examples for “Quarter Bridges” on the TLE 6208-6 G

**Table 1
Input Data Protocol**

BIT	
15	OVLO on/off
14	Underload SD on/off
13	Overcurrent SD on/off
12	HS-Switch 6
11	LS-Switch 6
10	HS-Switch 5
9	LS-Switch 5
8	HS-Switch 4
7	LS-Switch 4
6	HS-Switch 3
5	LS-Switch 3
4	HS-Switch 2
3	LS-Switch 2
2	HS-Switch 1
1	LS-Switch 1
0	Status Register Reset

H = ON
L = OFF

**Table 2
Diagnosis Data Protocol**

BIT	
15	Power supply fail
14	Underload
13	Overload
12	Status HS-Switch 6
11	Status LS-Switch 6
10	Status HS-Switch 5
9	Status LS-Switch 5
8	Status HS-Switch 4
7	Status LS-Switch 4
6	Status HS-Switch 3
5	Status LS-Switch 3
4	Status HS-Switch 2
3	Status LS-Switch 2
2	Status HS-Switch 1
1	Status LS-Switch 1
0	Temp. Prewarning

H = ON
L = OFF

Table 3
Fault Result Table

Fault	Diag.-Bit	Result
Overcurrent (load)	13	Only the failed output is switched OFF. Function and protection can be deactivated by bit No. 13.
Short circuit to GND (high-side-switch)	13	Only the failed output is switched OFF. Function and protection can be deactivated by bit No. 13.
Short circuit to V_s (low-side-switch)	13	Only the failed output is switched OFF. Function and protection can be deactivated by bit No. 13.
Temperature warning	0	Reaction of control device needed.
Temperature shut down (SD)	–	All outputs OFF.
Openload	14	Only the failed output is switched OFF. Function can be deactivated by bit No. 14.
Underload	14	Only the failed output is switched OFF. Function can be deactivated by bit No. 14.
Undervoltage lockout (UVLO)	15	All outputs OFF.
Overvoltage lockout (OVLO)	15	All outputs OFF. Function can be deactivated by bit No. 15.

H = failure;
L = no failure.

2 Electrical Characteristics

2.1 Absolute Maximum Ratings

Parameter	Symbol	Limit Values		Unit	Remarks
		min.	max.		

Voltages

Supply voltage	V_S	- 0.3	40	V	-
Supply voltage	V_S	- 1	-	V	$t < 0.5 \text{ s}; I_S > - 2 \text{ A}$
Logic supply voltage	V_{CC}	- 0.3	5.5	V	$0 \text{ V} < V_S < 40 \text{ V}$
Logic input voltages (DI, CLK, CSN, INH)	V_I	- 0.3	5.5	V	$0 \text{ V} < V_S < 40 \text{ V}$ $0 \text{ V} < V_{CC} < 5.5 \text{ V}$
Logic output voltage (DO)	V_{DO}	- 0.3	V_{CC}	V	$0 \text{ V} < V_S < 40 \text{ V}$ $0 \text{ V} < V_{CC} < 5.5 \text{ V}$

Currents

Output current (cont.), if Bit13 (OCSD) is set.	I_{OUT1-6}	-	-	A	internal limited
Output current (cont.), if Bit13 (OCSD) is deactivated.	I_{OUT1-6}	- 1.5	1.5	A	$V_{DS} = 12 \text{ V}$
		- 0.7	0.7	A	$V_{DS} = 20 \text{ V}$
		- 0.25	0.25	A	$V_{DS} = 40 \text{ V}$
Output current (peak), if Bit13 (OCSD) is set.	I_{OUT1-6}	-	-	A	internal limited
Output current (peak), if Bit13 (OCSD) is deactivated. $t_p < 50 \text{ ms}; t = 1 \text{ s};$	I_{OUT1-6}	- 2	2	A	$V_{DS} = 12 \text{ V}$
		- 0.9	0.9	A	$V_{DS} = 20 \text{ V}$
		- 0.3	0.3	A	$V_{DS} = 40 \text{ V}$

Temperatures

Junction temperature	T_j	- 40	150	°C	-
Storage temperature	T_{stg}	- 50	150	°C	-

Note: Maximum ratings are absolute ratings; exceeding any one of these values may cause irreversible damage to the integrated circuit.

2.2 Operating Range

Parameter	Symbol	Limit Values		Unit	Remarks
		min.	max.		
Supply voltage	V_S	$V_{UV\ OFF}$	40	V	After V_S rising above $V_{UV\ ON}$
Supply voltage slew rate	dV_S/dt	–	10	V/ μ s	–
Logic supply voltage	V_{CC}	4.75	5.50	V	–
Supply voltage increasing	V_S	– 0.3	$V_{UV\ ON}$	V	Outputs in tristate
Supply voltage decreasing	V_S	– 0.3	$V_{UV\ OFF}$	V	Outputs in tristate
Logic input voltage (DI, CLK, CSN, INH)	V_I	– 0.3	V_{CC}	V	–
SPI clock frequency	f_{CLK}	–	2	MHz	–
Junction temperature	T_j	– 40	150	°C	–

Thermal Resistances

Junction pin	$R_{thj-pin}$	–	25	K/W	measured to pin 7
Junction ambient	R_{thjA}	–	65	K/W	–

2.3 Electrical Characteristics

8 V < V_S < 40 V; 4.75 V < V_{CC} < 5.25 V; INH = High; all outputs open; $-40\text{ }^\circ\text{C} < T_j < 150\text{ }^\circ\text{C}$; unless otherwise specified

Parameter	Symbol	Limit Values			Unit	Test Condition
		min.	typ.	max.		

Current Consumption

Quiescent current	I_S	–	10	20	μA	INH = Low; $V_S = 13.2\text{ V}$; $T_j = 25\text{ }^\circ\text{C}$
Quiescent current	I_S	–	–	40	μA	INH = Low; $V_S = 13.2\text{ V}$
Supply current	I_S	–	2.0	4.0	mA	–
Logic-Supply current	I_{CC}	–	2	10	μA	INH = Low
Logic-Supply current	I_{CC}	–	1.6	3.0	mA	SPI not active

Over- and Under-Voltage Lockout

UV-Switch-ON voltage	$V_{UV\text{ ON}}$	–	6.5	7.0	V	V_S increasing
UV-Switch-OFF voltage	$V_{UV\text{ OFF}}$	5.5	6.0	6.6	V	V_S decreasing
UV-ON/OFF-Hysteresis	$V_{UV\text{ HY}}$	–	0.5	–	V	$V_{UV\text{ ON}} - V_{UV\text{ OFF}}$
OV-Switch-OFF voltage	$V_{OV\text{ OFF}}$	34	37	40	V	V_S increasing
OV-Switch-ON voltage	$V_{OV\text{ ON}}$	28	32	36	V	V_S decreasing
OV-ON/OFF-Hysteresis	$V_{OV\text{ HY}}$	–	5.0	–	V	$V_{OV\text{ OFF}} - V_{OV\text{ ON}}$

2.3 Electrical Characteristics (cont'd)

$8\text{ V} < V_S < 40\text{ V}$; $4.75\text{ V} < V_{CC} < 5.25\text{ V}$; INH = High; all outputs open; $-40\text{ }^\circ\text{C} < T_j < 150\text{ }^\circ\text{C}$; unless otherwise specified

Parameter	Symbol	Limit Values			Unit	Test Condition
		min.	typ.	max.		

Outputs OUTH1-6 and OUTL1-6

Static Drain-Source-On Resistance

Source (High-Side) $I_{OUT} = -0.5\text{ A}$	$R_{DS\ ON\ H}$	-	0.9	1.3	Ω	$8\text{ V} < V_S < 40\text{ V}$ $T_j = 25\text{ }^\circ\text{C}$
			-	2.0	Ω	$8\text{ V} < V_S < 40\text{ V}$
			2.0	-	Ω	$V_{S\ OFF} < V_S \leq 8\text{ V}$ $T_j = 25\text{ }^\circ\text{C}$
			-	4.0	Ω	$V_{S\ OFF} < V_S \leq 8\text{ V}$
Sink (Low-Side) $I_{OUT} = 0.5\text{ A}$	$R_{DS\ ON\ L}$	-	0.8	1.2	Ω	$8\text{ V} < V_S < 40\text{ V}$ $T_j = 25\text{ }^\circ\text{C}$
			-	2.0	Ω	$8\text{ V} < V_S < 40\text{ V}$
			2.0	-	Ω	$V_{S\ OFF} < V_S \leq 8\text{ V}$ $T_j = 25\text{ }^\circ\text{C}$
			-	4.0	Ω	$V_{S\ OFF} < V_S \leq 8\text{ V}$

Note: Values of $R_{DS\ ON}$ for $V_{S\ OFF} < V_S \leq 8\text{ V}$ are guaranteed by design.

Leakage Current

Source-Output-Stage 1 to 6	I_{QLH}	- 1	-	-	μA	$V_{OUTH1-6} = 0\text{ V}$ $T_j = 25\text{ }^\circ\text{C}$
Source-Output-Stage 1 to 6	I_{QLH}	- 5	-	-	μA	$V_{OUTH1-6} = 0\text{ V}$
Sink-Output-Stage 1 to 6	I_{QLL}	-	-	1	μA	$V_{OUTL1-6} = V_S$ $T_j = 25\text{ }^\circ\text{C}$
Sink-Output-Stage 1 to 6	I_{QLL}	-	-	5	μA	$V_{OUTL1-6} = V_S$

2.3 Electrical Characteristics (cont'd)

8 V < V_S < 40 V; 4.75 V < V_{CC} < 5.25 V; INH = High; all outputs open; - 40 °C < T_j < 150 °C; unless otherwise specified

Parameter	Symbol	Limit Values			Unit	Test Condition
		min.	typ.	max.		

Overcurrent

Source shutdown threshold	I_{SDU}	- 2.0	- 1.5	- 1.0	A	-
Sink shutdown threshold	I_{SDL}	1.0	1.5	2.0	A	-
Current limit	I_{OCL}	-	3.0	5.0	A	sink and source
Shutdown delay time	t_{dSD}	10	25	50	µs	sink and source

Open Circuit

Detection current	I_{OCD}	15	30	50	mA	-
Delay time	t_{dOC}	200	350	600	µs	-

Delay Time from Stand-by to Data In

Setup time	t_{set}	-	-	100	µs	-
------------	-----------	---	---	-----	----	---

Note: setup time is guaranteed by design

Output Delay Times; $V_S = 13.2$ V; $R_{Load} = 25$ Ω (device not in stand-by for $t > 1$ ms)

Source (high-side) ON	$t_{d ON H}$	-	7.5	12	µs	-
Source (high-side) OFF	$t_{d OFF H}$	-	3	6	µs	-
Sink (low-side) ON	$t_{d ON L}$	-	6.5	12	µs	-
Sink (low-side) OFF	$t_{d OFF L}$	-	2	5	µs	-
Dead time H to L	$t_{D HL}$	1.5	-	-	µs	$t_{d ON L} - t_{d OFF H}$
Dead time L to H	$t_{D LH}$	2.5	-	-	µs	$t_{d ON H} - t_{d OFF L}$

2.3 Electrical Characteristics (cont'd)

$8\text{ V} < V_S < 40\text{ V}$; $4.75\text{ V} < V_{CC} < 5.25\text{ V}$; INH = High; all outputs open; $-40\text{ }^\circ\text{C} < T_j < 150\text{ }^\circ\text{C}$; unless otherwise specified

Parameter	Symbol	Limit Values			Unit	Test Condition
		min.	typ.	max.		

Output Switching Times; $V_S = 13.2\text{ V}$; $R_{Load} = 25\ \Omega$ (device not in stand-by for $t > 1\text{ ms}$)

Source (high-side) rise-time	t_{ONH}	–	4	8	μs	–
Source (high-side) fall-time	t_{OFFH}	–	2	3	μs	–
Sink (low-side) fall-time	t_{ONL}	–	1	3	μs	–
Sink (low-side) rise-time	t_{OFFL}	–	1	2	μs	–

Clamp Diodes Forward Voltage

Upper	V_{FU}	–	0.9	1.3	V	$I_F = 0.5\text{ A}$
Lower	V_{FL}	–	0.9	1.3	V	$I_F = 0.5\text{ A}$

Inhibit Input

H-input voltage threshold	V_{IH}	–	–	0.7	V_{CC}	–
L-input voltage threshold	V_{IL}	0.2	–	–	V_{CC}	–
Hysteresis of input voltage	V_{IHYS}	50	200	500	mV	–
Pull down current	I_I	10	25	50	μA	$V_I = 0.2 \times V_{CC}$
Input capacitance	C_I	–	10	15	pF	$0\text{ V} < V_{CC} < 5.25\text{ V}$

Note: Capacitances are guaranteed by design

2.3 Electrical Characteristics (cont'd)

8 V < V_S < 40 V; 4.75 V < V_{CC} < 5.25 V; INH = High; all outputs open; - 40 °C < T_j < 150 °C; unless otherwise specified

Parameter	Symbol	Limit Values			Unit	Test Condition
		min.	typ.	max.		

SPI-Interface

Delay Time from Stand-by to Data In

Setup time	t_{set}	–	–	100	µs	–
------------	-----------	---	---	-----	----	---

Logic Inputs DI, CLK and CSN

H-input voltage threshold	V_{IH}	–	–	0.7	V_{CC}	–
L-input voltage threshold	V_{IL}	0.2	–	–	V_{CC}	–
Hysteresis of input voltage	V_{IHY}	50	200	500	mV	–
Pull up current at pin CSN	I_{ICSN}	– 50	– 25	– 10	µA	$V_{CSN} = 0.7 \times V_{CC}$
Pull down current at pin DI	I_{IDI}	10	25	50	µA	$V_{DI} = 0.2 \times V_{CC}$
Pull down current at pin CLK	I_{ICLK}	10	25	50	µA	$V_{CLK} = 0.2 \times V_{CC}$
Input capacitance at pin CSN, DI or CLK	C_I	–	10	15	pF	0 V < V_{CC} < 5.25 V

Note: Capacitances are guaranteed by design

Logic Output DO

H-output voltage level	V_{DOH}	V_{CC} – 1.0	V_{CC} – 0.7	–	V	$I_{DOH} = 1$ mA
L-output voltage level	V_{DOL}	–	0.2	0.4	V	$I_{DOL} = -1.6$ mA
Tri-state leakage current	I_{DOLK}	– 10	–	10	µA	$V_{CSN} = V_{CC}$ 0 V < V_{DO} < V_{CC}
Tri-state input capacitance	C_{DO}	–	10	15	pF	$V_{CSN} = V_{CC}$ 0 V < V_{CC} < 5.25 V

Note: Capacitances are guaranteed by design

2.3 Electrical Characteristics (cont'd)

8 V < V_S < 40 V; 4.75 V < V_{CC} < 5.25 V; INH = High; all outputs open; - 40 °C < T_j < 150 °C; unless otherwise specified

Parameter	Symbol	Limit Values			Unit	Test Condition
		min.	typ.	max.		

Data Input Timing

Clock period	t_{pCLK}	500	–	–	ns	–
Clock high time	t_{CLKH}	250	–	–	ns	–
Clock low time	t_{CLKL}	250	–	–	ns	–
Clock low before CSN low	t_{bef}	250	–	–	ns	–
CSN setup time	t_{lead}	250	–	–	ns	–
CSN high time	t_{CSNH}	12	–	–	µs	–
CLK setup time	t_{lag}	250	–	–	ns	–
Clock low after CSN high	t_{beh}	250	–	–	ns	–
DI setup time	t_{DISU}	40	–	–	ns	–
DI hold time	t_{DIHO}	40	–	–	ns	–
Input signal rise time at pin DI, CLK and CSN	t_{rIN}	–	–	200	ns	–
Input signal fall time at pin DI, CLK and CSN	t_{fIN}	–	–	200	ns	–

Data Output Timing

DO rise time	t_{rDO}	–	50	100	ns	$C_L = 100$ pF
DO fall time	t_{fDO}	–	50	100	ns	$C_L = 100$ pF
DO enable time	t_{ENDO}	–	–	250	ns	low impedance
DO disable time	t_{DISDO}	–	–	250	ns	high impedance
DO valid time	t_{VADO}	–	100	250	ns	$V_{DO} < 0.2 V_{CC}$; $V_{DO} > 0.7 V_{CC}$; $C_L = 100$ pF

Note: SPI timing is guaranteed by design. CSN high time: This is the minimum time the user must wait between SPI commands.

2.3 Electrical Characteristics (cont'd)

8 V < V_S < 40 V; 4.75 V < V_{CC} < 5.25 V; INH = High; all outputs open; $-40\text{ }^\circ\text{C} < T_j < 150\text{ }^\circ\text{C}$;
unless otherwise specified

Parameter	Symbol	Limit Values			Unit	Test Condition
		min.	typ.	max.		

Thermal Prewarning and Shutdown

Thermal prewarning junction temperature	T_{JPW}	120	145	170	$^\circ\text{C}$	–
Temperature prewarning hysteresis	ΔT	–	30	–	K	–
Thermal shutdown junction temperature	T_{JSD}	150	175	200	$^\circ\text{C}$	–
Thermal switch-on junction temperature	T_{JSO}	120	–	170	$^\circ\text{C}$	–
Temperature shutdown hysteresis	ΔT	–	30	–	K	–
Ratio of SD to PW temperature	T_{JSD} / T_{JPW}	1.05	1.20	–	–	–

Note: Temperatures are guaranteed by design

3 Timing Diagrams

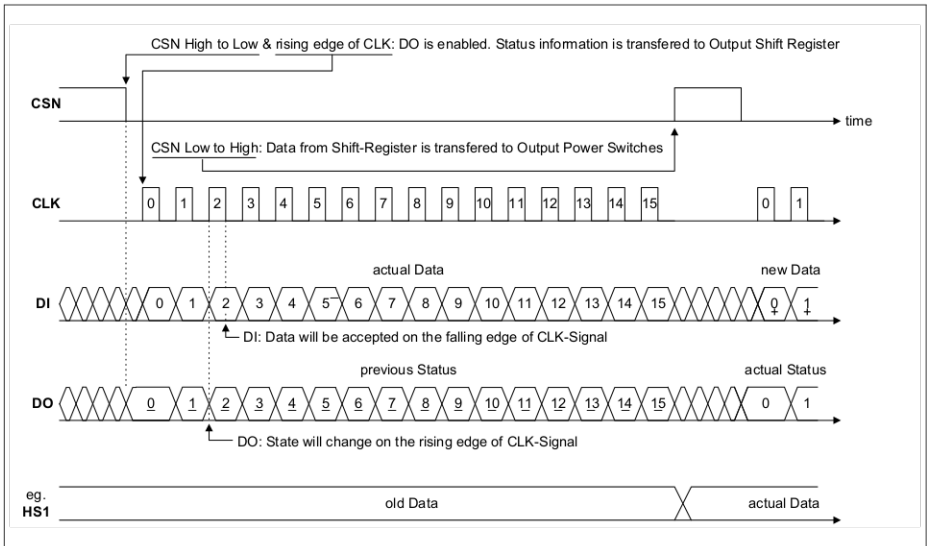

Figure 4
Standard Data Transfer Timing

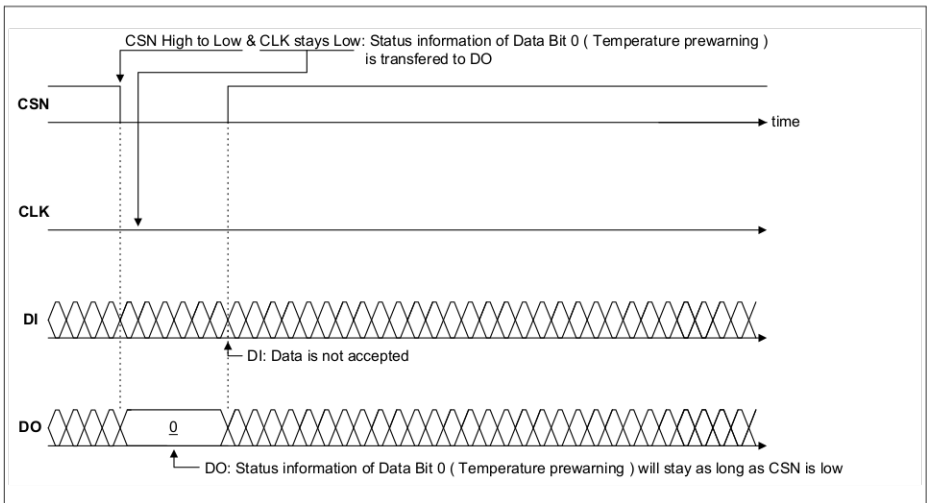

Figure 5
Timing for Temperature Prewarning only

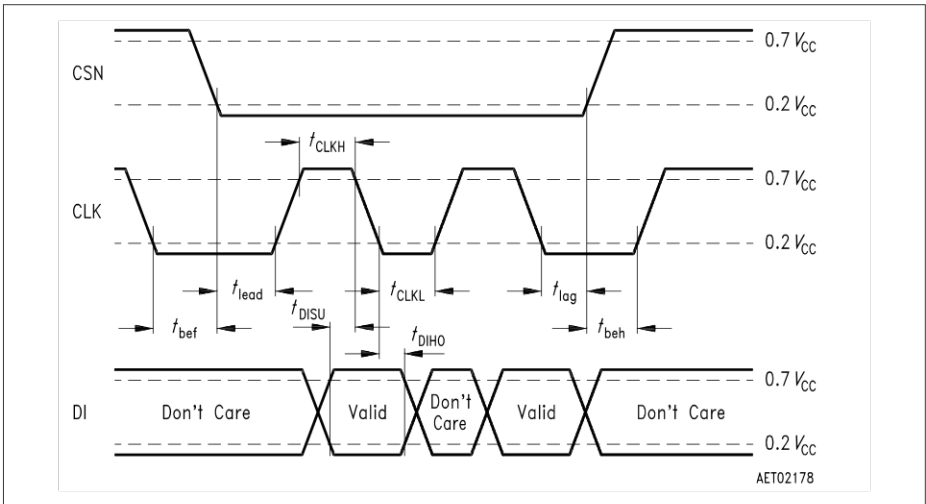

Figure 6
SPI-Input Timing

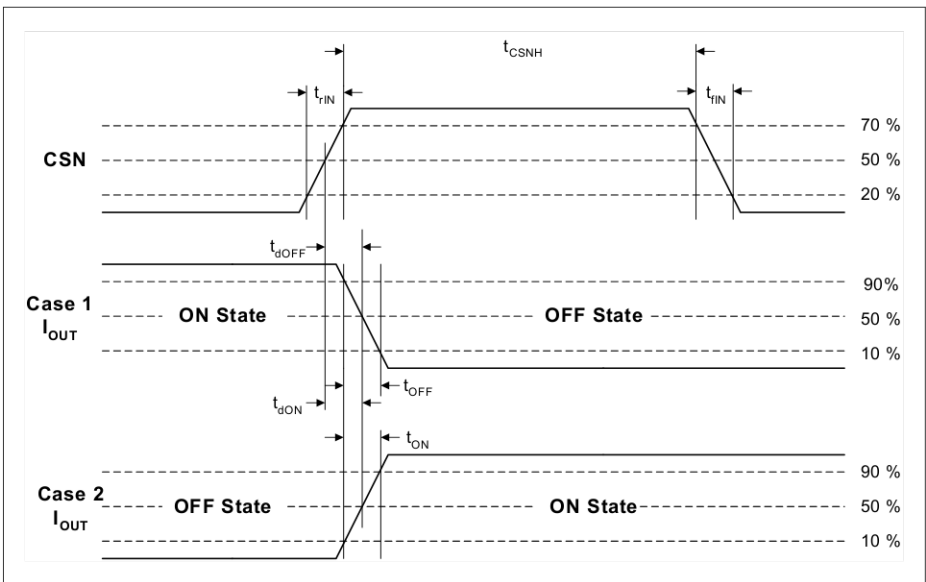

Figure 7
Turn OFF/ON Time

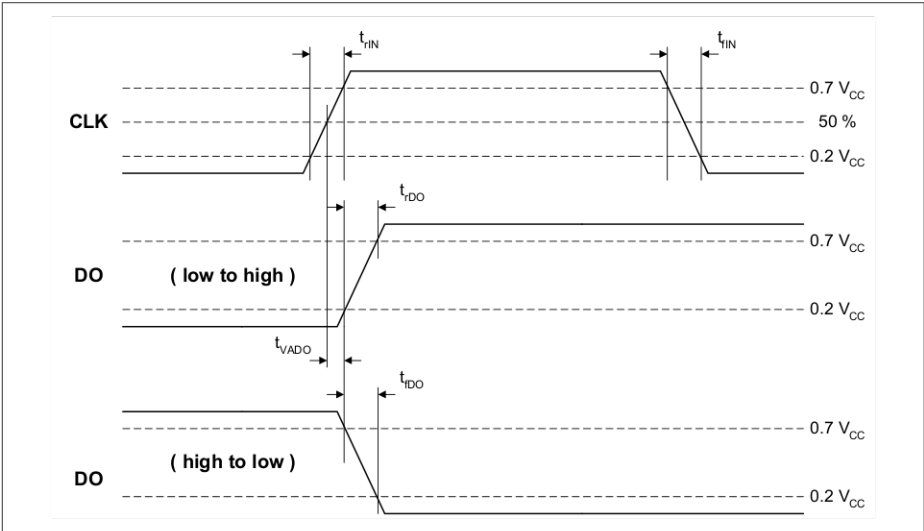

Figure 8
DO Valid Data Delay Time and Valid Time

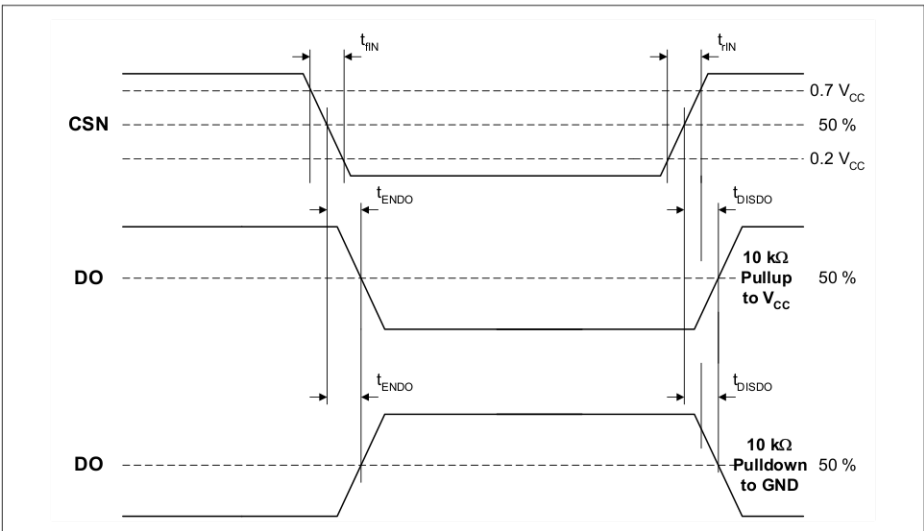

Figure 9
DO Enable and Disable Time

4 Application

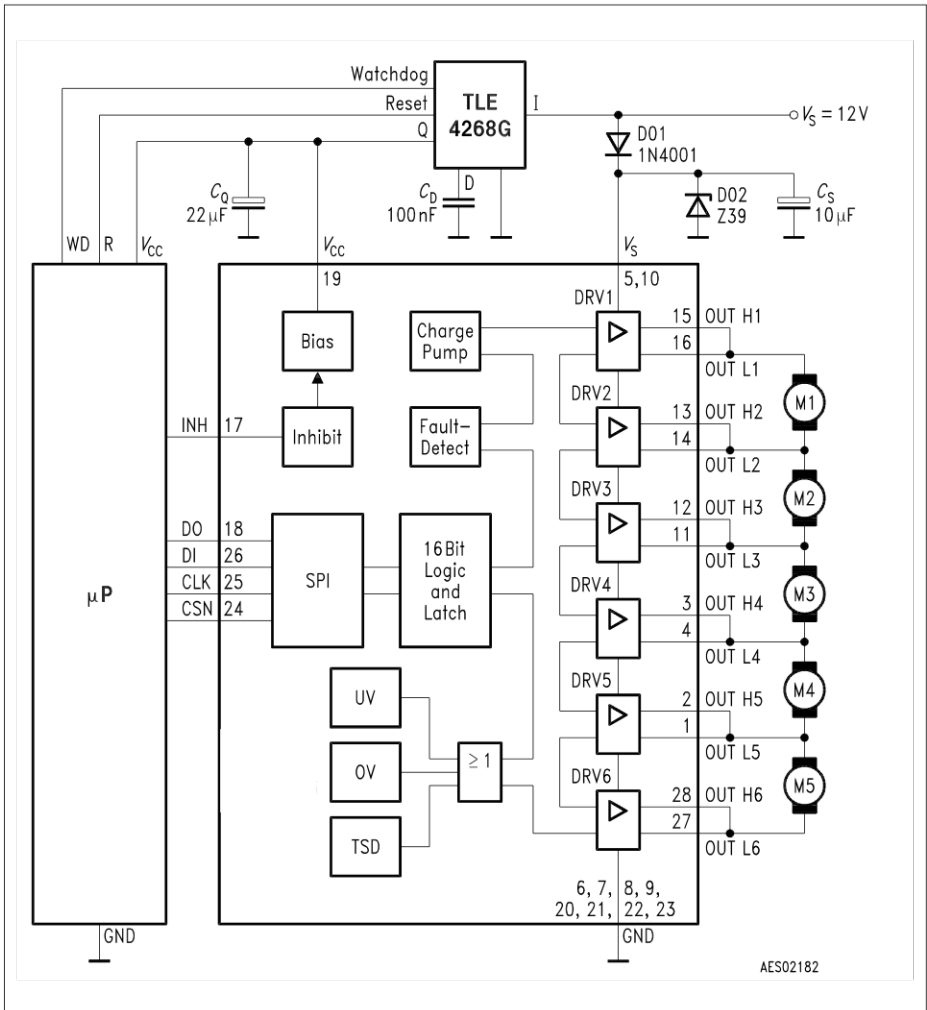
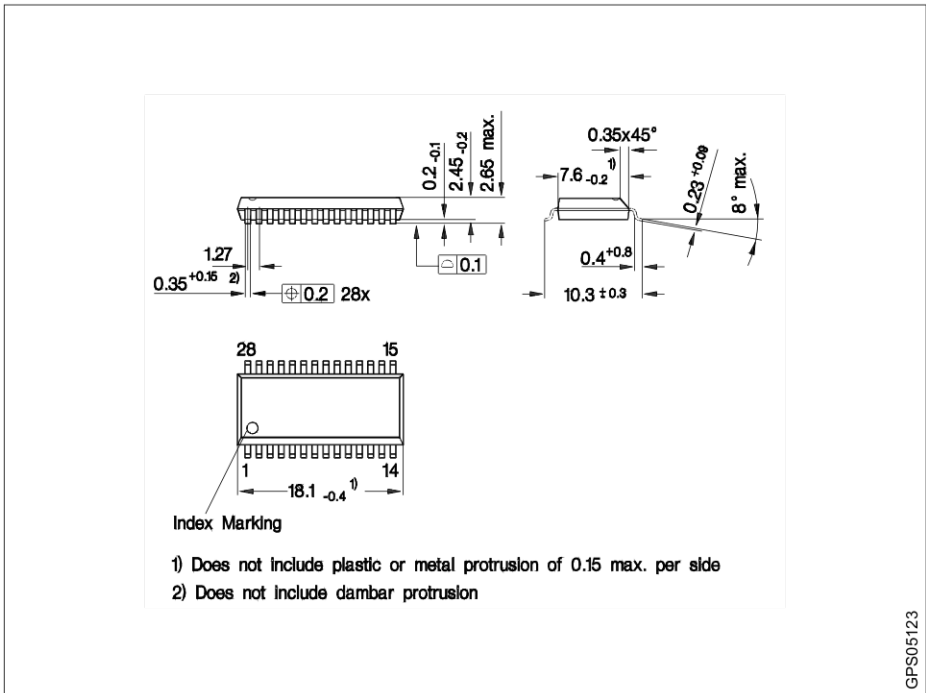

Figure 10
Application Circuit

5 Package Outlines



GPS05123

Figure 11 PG-DSO-28-41 (Plastic Dual Small Outline)

Green Product (RoHS compliant)

To meet the world-wide customer requirements for environmentally friendly products and to be compliant with government regulations the device is available as a green product. Green products are RoHS-Compliant (i.e Pb-free finish on leads and suitable for Pb-free soldering according to IPC/JEDEC J-STD-020).

You can find all of our packages, sorts of packing and others in our Infineon Internet Page "Products": <http://www.infineon.com/products>.

SMD = Surface Mounted Device

Dimensions in mm

Revision History

Version	Date	Changes
Rev. 1.2	2013-10-17	Internal Package update to PG-DSO-28-41
Rev. 1.1	2007-09-12	<p>RoHS-compliant version of the TLE 6208-6 G</p> <ul style="list-style-type: none">• All pages: Infineon logo updated• Page 1: “added AEC qualified” and “RoHS” logo, “Green Product (RoHS compliant)” and “AEC qualified” statement added to feature list, package name changed to RoHS compliant versions, package picture updated, ordering code removed• Page 23: Package name changed to RoHS compliant versions, “Green Product” description added• Page 24-25: added Revision History and Legal Disclaimer

Edition 2013-10-17

**Published by
Infineon Technologies AG
81726 Munich, Germany**

**© 10/17/13 Infineon Technologies AG
All Rights Reserved.**

Legal Disclaimer

The information given in this document shall in no event be regarded as a guarantee of conditions or characteristics. With respect to any examples or hints given herein, any typical values stated herein and/or any information regarding the application of the device, Infineon Technologies hereby disclaims any and all warranties and liabilities of any kind, including without limitation, warranties of non-infringement of intellectual property rights of any third party.

Information

For further information on technology, delivery terms and conditions and prices, please contact the nearest Infineon Technologies Office (www.infineon.com).

Warnings

Due to technical requirements, components may contain dangerous substances. For information on the types in question, please contact the nearest Infineon Technologies Office.

Infineon Technologies components may be used in life-support devices or systems only with the express written approval of Infineon Technologies, if a failure of such components can reasonably be expected to cause the failure of that life-support device or system or to affect the safety or effectiveness of that device or system. Life support devices or systems are intended to be implanted in the human body or to support and/or maintain and sustain and/or protect human life. If they fail, it is reasonable to assume that the health of the user or other persons may be endangered.