

Ultrafast, Soft Recovery Diode

- Ultra fast Recovery
- Ultra soft Recovery
- Very Low IRRM
- Very Low Qrr
- Specified at Operating Conditions
- Lead-Free

V_R	600	V
$V_{F(Max)}$	1.7	V
Qrr	65	nC
$D_{I(rec)M}/dt$	240	A/μs



Benefits

- Reduced RFI and EMI
- Reduced Power Loss in Diode and Switching Transistor
- Higher Frequency Operation
- Reduced Snubbing
- Reduced Parts Count

Description

International Rectifier's HFA08TB60PbF is a state of the art ultra fast recovery diode. Employing the latest in epitaxial construction and advanced processing techniques it features a superb combination of characteristics which result in performance which is unsurpassed by any rectifier previously available. With basic ratings of 600 volts and 8 amps per Leg continuous current, the HFA08TB60PbF is especially well suited for use as the companion diode for IGBTs and MOSFETs. In addition to ultra fast recovery time, the ultra fast recovery diode product line features extremely low values of peak recovery current (IRRM) and does not exhibit any tendency to "snap-off" during the tb portion of recovery. The ultra fast recovery diode features combine to offer designers a rectifier with lower noise and significantly lower switching losses in both the diode and the switching transistor. These ultra fast recovery diode advantages can help to significantly reduce snubbing, component count and heat sink sizes. The HFA08TB60PbF is ideally suited for applications in power supplies and power conversion systems (such as inverters), motor drives, and many other similar applications where high speed, high efficiency is needed.

Base part number	Package Type	Standard Pack		Orderable Part Number
		Form	Quantity	
HFA08TB60PbF	TO-220AC	Tube	50	HFA08TB60PbF

Absolute Maximum Ratings

	Parameter	Max.	Units
V_R	Cathode -to – Anode Voltage	600	V
$I_F @ T_C = 100^\circ C$	Continuous Forward Current	8.0	A
I_{FSM}	Single Pulse Forward Current	60	
I_{FRM}	Maximum Repetitive Forward Current	24	
$P_D @ T_C = 25^\circ C$	Maximum Power Dissipation	36	W
$P_D @ T_C = 100^\circ C$	Maximum Power Dissipation	14	
T_J T_{STG}	Operating Junction and Storage Temperature Range	-55 to + 150	°C

Electrical Characteristics @ T_J = 25°C (unless otherwise specified)

	Parameter	Min.	Typ.	Max.	Units	Conditions
V _{BR}	Cathode Anode Breakdown Voltage	600	—	—	V	I _R = 100μA I _F = 8.0A I _F = 16A I _F = 8.0A, T _J = 125°C
V _{FM}	Max Forward Voltage	—	1.4	1.7		
		—	1.7	2.1		
		—	1.4	1.7		
I _{RM}	Max Reverse Leakage Current	—	0.3	5.0	μA	V _R = V _R Rated See Fig. 2 T _J = 125°C, V _R = 0.8 x V _R Rated
		—	100	500		
C _T	Junction Capacitance	—	10	25	pF	V _R = 200V See Fig. 3
L _S	Series Inductance	—	8.0	—	nH	Measured lead to lead 5mm from package body

Dynamic Recovery Characteristics @ T_J = 25°C (unless otherwise specified)

	Parameter	Min.	Typ.	Max.	Units	Conditions
t _{rr}	Reverse Recovery Time See Fig. 5	—	18	—	ns	I _F = 1.0A, di/dt = 200A/μs, V _R = 30V T _J = 25°C T _J = 125°C
t _{rr1}		—	37	55		
t _{rr2}		—	55	90		
I _R RM1	Peak Recovery Current See Fig. 6	—	3.5	5.0	A	I _F = 8.0A V _R = 200V di/dt = 200A/μs
I _R RM2		—	4.5	8.0		
Q _{rr1}	Reverse Recovery Charge See Fig.7	—	65	138	nC	T _J = 25°C T _J = 125°C
Q _{rr2}		—	124	360		
di _{(rec)M} /dt1	Peak Rate of Fall of Recovery Current	—	240	—	A/μs	T _J = 25°C T _J = 125°C
di _{(rec)M} /dt2	During tb See Fig.8	—	210	—		

Thermal Resistance

	Parameter	Min.	Typ.	Max.	Units
T _{lead} ①	Lead Temperature	—	—	300	°C/W
R _{θJC}	Thermal Resistance, Junction to Case	—	—	3.5	
R _{θJA} ②	Thermal Resistance, Junction to Ambient	—	—	62	
R _{θCS} ③	Thermal Resistance, Case to Heat Sink	—	0.50	—	
Wt	Weight	—	2.0	—	g
		—	0.07	—	(oz)
T	Mounting Torque	6.0	—	12	Kg-cm
		5.0	—	10	lbf•in

① 0.063 in. from Case (1.6mm) for 10 sec

② Typical Socket Mount

③ Mounting Surface, Flat, Smooth and Greased

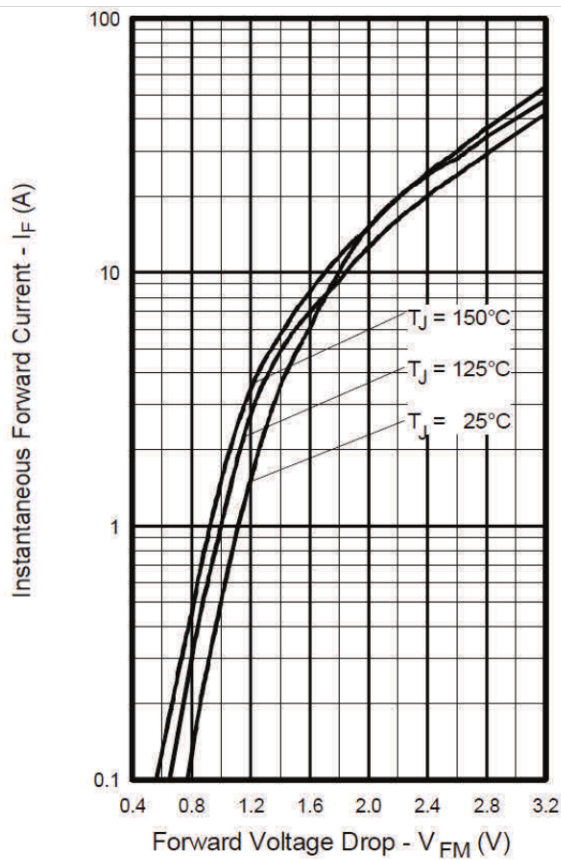

Fig. 1 - Maximum Forward Voltage Drop vs. Instantaneous Forward Current

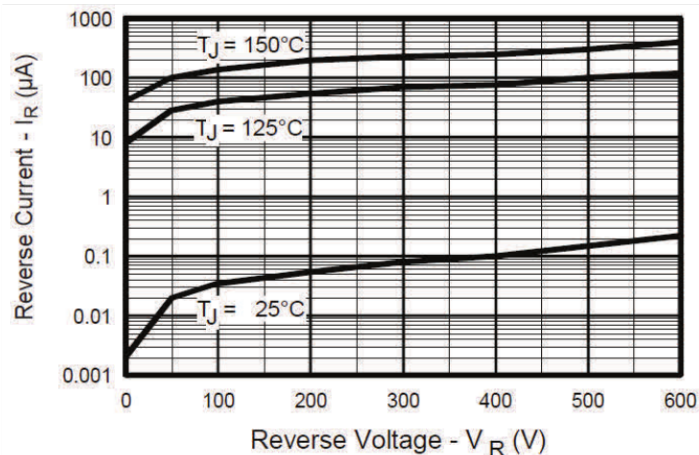

Fig. 2 - Typical Reverse Current vs. Reverse Voltage

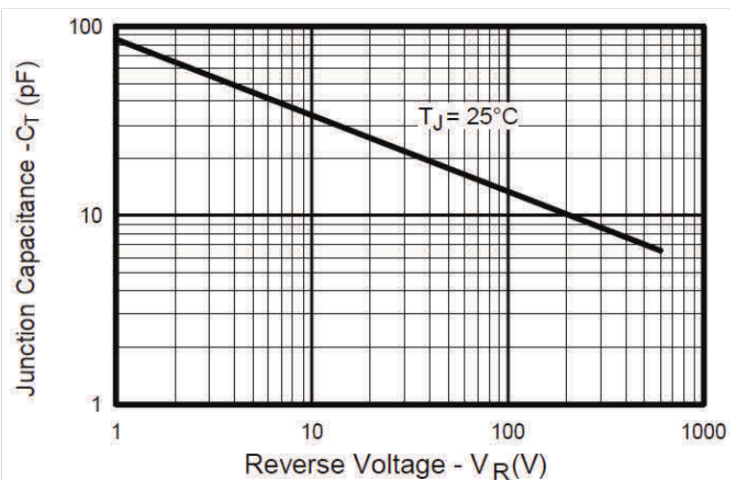

Fig. 3 - Typical Junction Capacitance vs. Reverse Voltage

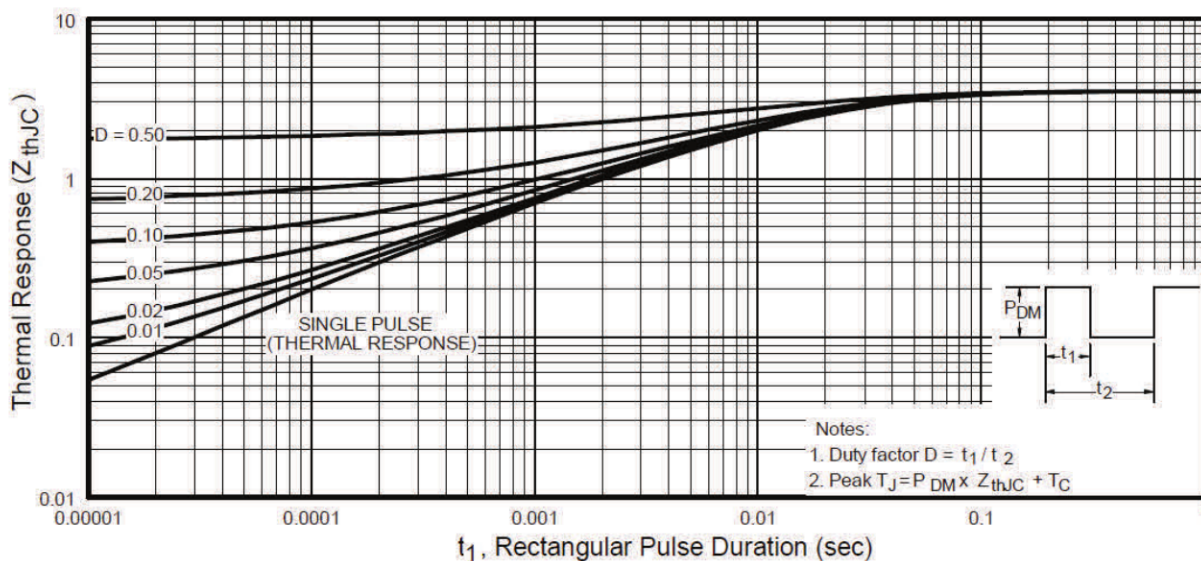

Fig. 4 - Maximum Thermal Impedance Z_{thjc} Characteristics

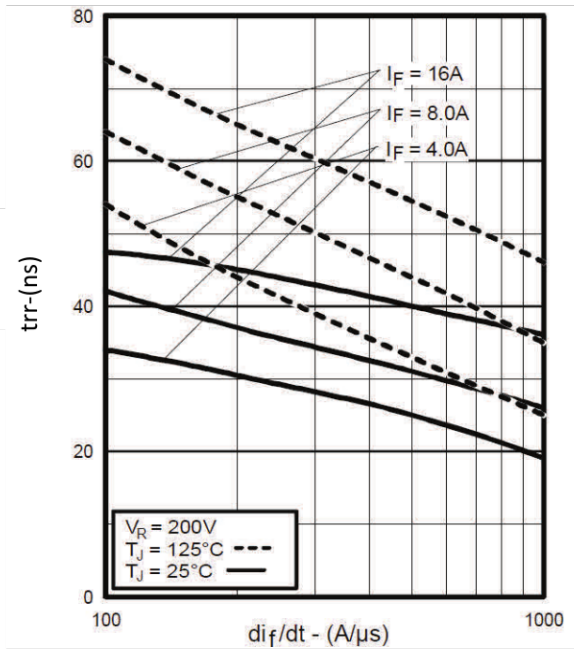

Fig. 5 - Typical Reverse Recovery vs. di f/dt

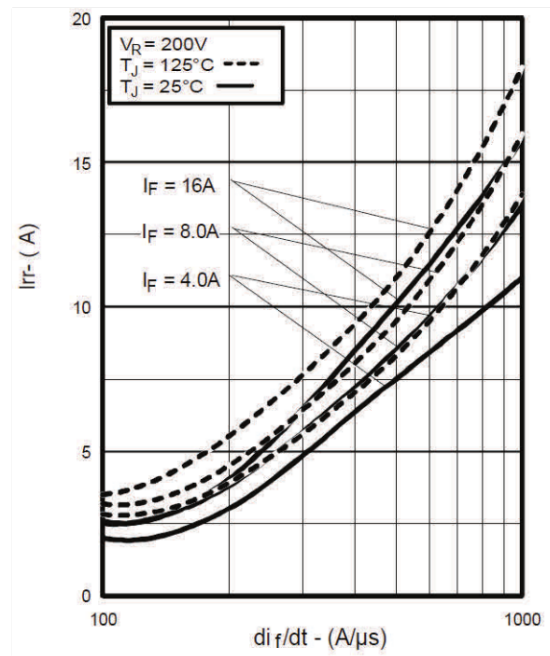

Fig. 6 - Typical Recovery Current vs. di f/dt

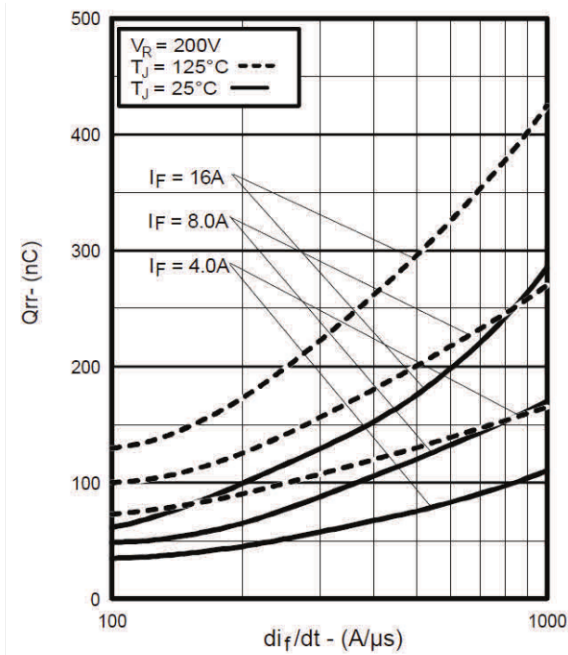

Fig. 7 - Typical Stored Charge vs. di f/dt

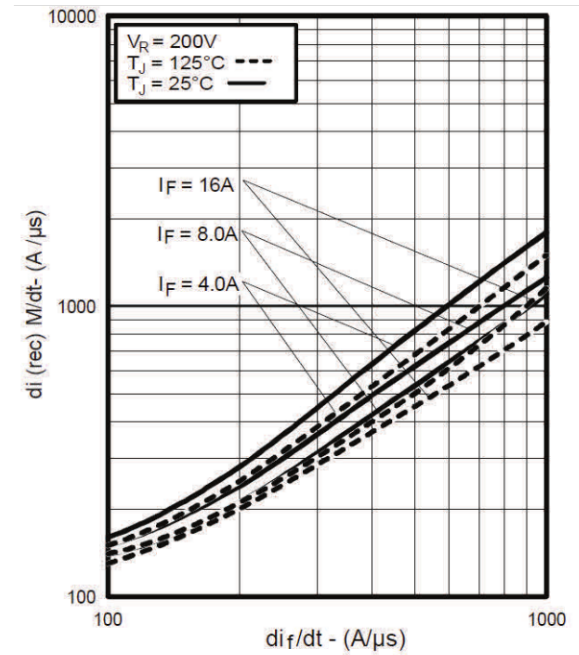

Fig. 8 - Typical di(rec)M/dt vs. di f/dt

REVERSE RECOVERY CIRCUIT

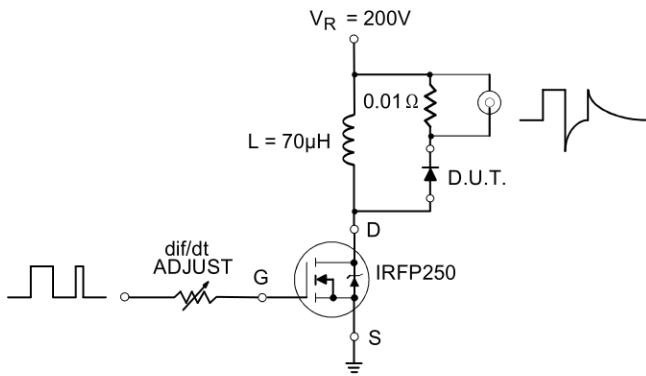
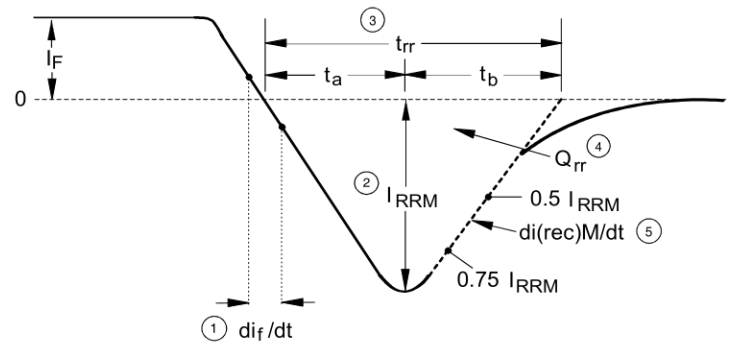

Fig. 9 - Reverse Recovery Parameter Test Circuit



- 1. di/dt - Rate of change of current through zero crossing
- 2. I_{RRM} - Peak reverse recovery current
- 3. t_{rr} - Reverse recovery time measured from zero crossing point of negative going I_F to point where a line passing through $0.75 I_{RRM}$ and $0.50 I_{RRM}$ extrapolated to zero current
- 4. Q_{rr} - Area under curve defined by t_{rr} and I_{RRM}
- 5. $di^{(rec)M}/dt$ - Peak rate of change of current during t_b portion of t_{rr}

$$Q_{rr} = \frac{t_{rr} \times I_{RRM}}{2}$$

Fig. 10 - Reverse Recovery Waveform and Definitions

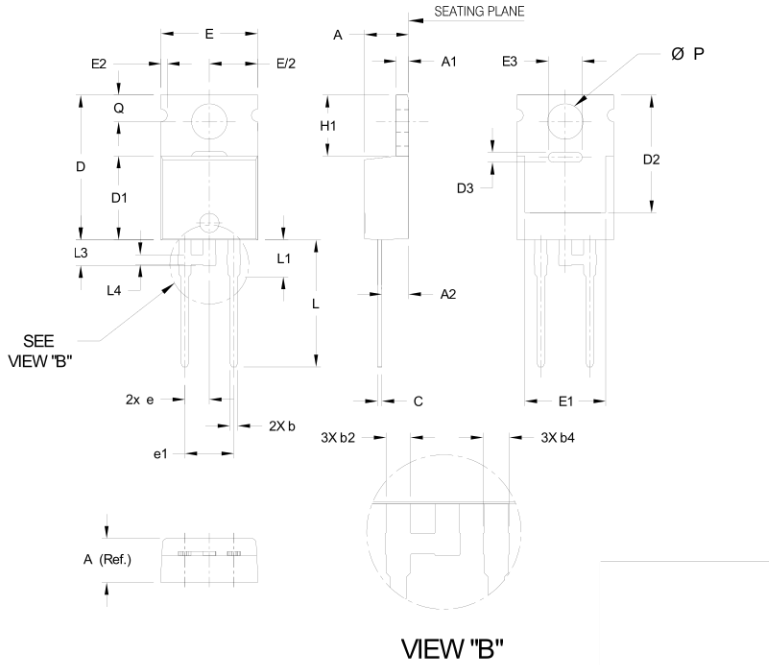
TO-220AC Package Outline (Dimensions are shown in millimeters (inches))

SYMBOL	MIN.	NOM.	MAX.
A	3.56	4.57	4.83
A1	1.14	1.27	1.40
A2	2.03	2.77	2.92
b	0.38	0.81	1.01
b2	1.17	1.27	1.37
b4	1.25	1.35	1.45
c	0.36	0.46	0.61
D	14.32	15.00	16.51
D1	8.38	8.69	9.02
D2	11.68	12.19	12.88
D3	0.82	1.02	1.22
E	9.65	10.00	10.67
E1	6.86	8.39	8.89
E2	--	--	0.76
E3	3.30	3.50	3.70
e	2.54 BASIC		
e1	5.08 BASIC		
H1	5.84	6.31	6.86
L	12.70	13.16	14.73
L1	3.56	3.83	4.06
L3	2.31	2.56	2.81
L4	0.76	1.01	1.27
øP	3.54	3.68	4.08
Q	2.54	2.74	3.42

NOTES:

1. DIMENSIONING AND TOLERANCING AS PER ASME Y14.5M 1994.
2. DIMENSIONS ARE SHOWN IN MILLIMETERS.

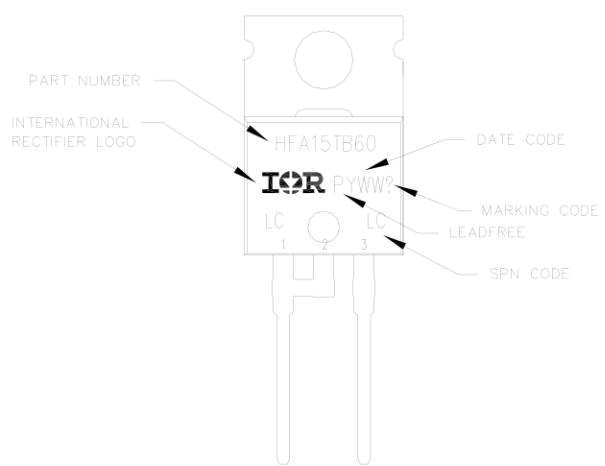
TO-220AC Part Marking Information

Note: For the most current drawing please refer to IR website at <http://www.irf.com/package/>

Qualification Information[†]

Qualification Level	Industrial (per JEDEC JESD47F) ^{††}	
Moisture Sensitivity Level	TO-220AC	N/A
RoHS Compliant	Yes	

† Qualification standards can be found at International Rectifier’s web site: <http://www.irf.com/product-info/reliability/>

†† Applicable version of JEDEC standard at the time of product release.