

Ultrafast, Soft Recovery Diode

- Ultrafast Recovery
- Ultrasoft Recovery
- Very Low I_{RRM}
- Very Low Q_{rr}
- Specified at Operating Conditions
- Lead-Free

Benefits

- Reduced RFI and EMI
- Reduced Power Loss in Diode and Switching Transistor
- Higher Frequency Operation
- Reduced Snubbing
- Reduced Parts Count

$V_R = 600V$
$V_F = 1.7V$
$Q_{rr}^* = 84nC$
$D_{I(rec)M}/dt = 188A/\mu s$
* 125°C



Description

International Rectifier's HFA15TB60PbF is a state of the art ultrafast recovery diode. Employing the latest in epitaxial construction and advanced processing techniques it features a superb combination of characteristics which result in performance which is unsurpassed by any rectifier previously available. With basic ratings of 600 volts and 8 amps per Leg continuous current, the HFA15TB60PbF is especially well suited for use as the companion diode for IGBTs and MOSFETs. In addition to ultra fast recovery time, the ultrafast recovery diode product line features extremely low values of peak recovery current (IRRM) and does not exhibit any tendency to "snap-off" during the t_b portion of recovery. The ultrafast recovery diode features combine to offer designers a rectifier with lower noise and significantly lower switching losses in both the diode and the switching transistor. These ultrafast recovery diode advantages can help to significantly reduce snubbing, component count and heat sink sizes. The HFA15TB60PbF is ideally suited for applications in power supplies and power conversion systems (such as inverters), motor drives, and many other similar applications where high speed, high efficiency is needed.

Base part number	Package Type	Standard Pack		Orderable Part Number
		Form	Quantity	
HFA15TB60PbF	TO-220AC	Tube	50	HFA15TB60PbF

Absolute Maximum Ratings

	Parameter	Max.	Units
V_R	Cathode -to – Anode Voltage	600	V
$I_F @ T_C = 100^\circ C$	Continuous Forward Current	15	A
I_{FSM}	Single Pulse Forward Current	150	
I_{FRM}	Maximum Repetitive Forward Current	60	
$P_D @ T_C = 25^\circ C$	Maximum Power Dissipation	74	W
$P_D @ T_C = 100^\circ C$	Maximum Power Dissipation	29	
T_J T_{STG}	Operating Junction and Storage Temperature Range	-55 to + 150	°C

Electrical Characteristics @ T_J = 25°C (unless otherwise specified)

	Parameter	Min.	Typ.	Max.	Units	Conditions
V _{BR}	Cathode Anode Breakdown Voltage	600	—	—	V	I _R = 100μA I _F = 15A I _F = 30A I _F = 30A, T _J = 125°C
V _{FM}	Max Forward Voltage	—	1.3	1.7		
		—	1.5	2.0		
		—	1.2	1.6		
I _{RM}	Max Reverse Leakage Current	—	1.0	10	μA	V _R = V _R Rated See Fig. 2 T _J = 125°C, V _R = 0.8 x V _R Rated
		—	400	1000		
C _T	Junction Capacitance	—	25	50	pF	V _R = 200V See Fig. 3
L _S	Series Inductance	—	8.0	—	nH	Measured lead to lead 5mm from package body

Dynamic Recovery Characteristics @ T_J = 25°C (unless otherwise specified)

	Parameter	Min.	Typ.	Max.	Units	Conditions
t _{rr}	Reverse Recovery Time See Fig. 5	—	19	—	ns	I _F = 1.0A, di/dt = 200A/μs, V _R = 30V T _J = 25°C
t _{rr1}		—	42	60		
t _{rr2}		—	74	120		
I _R RRM1	Peak Recovery Current See Fig. 6	—	4.0	6.0	A	I _F = 15A V _R = 200V di/dt = 200A/μs
I _R RRM2		—	6.5	10		
Q _{rr1}	Reverse Recovery Charge See Fig.7	—	84	180	nC	T _J = 25°C
Q _{rr2}		—	241	600		
di _{(rec)M} /dt1	Peak Rate of Fall of Recovery Current	—	188	—	A/μs	T _J = 25°C
di _{(rec)M} /dt2	During t _b See Fig.8	—	160	—		T _J = 125°C

Thermal –Mechanical Characteristics

	Parameter	Min.	Typ.	Max.	Units
T _{lead} ①	Lead Temperature	—	—	300	°C
R _{θJC}	Thermal Resistance, Junction to Case	—	—	1.7	K/W
R _{θJA} ②	Thermal Resistance, Junction to Ambient	—	—	80	
R _{θCS} ③	Thermal Resistance, Case to Heat Sink	—	0.50	—	
Wt	Weight	—	2.0	—	g
		—	0.07	—	(oz)
T	Mounting Torque	6.0	—	12	Kg-cm
		5.0	—	10	lbf•in

① 0.063 in. from Case (1.6mm) for 10 sec

② Typical Socket Mount

③ Mounting Surface, Flat, Smooth and Greased

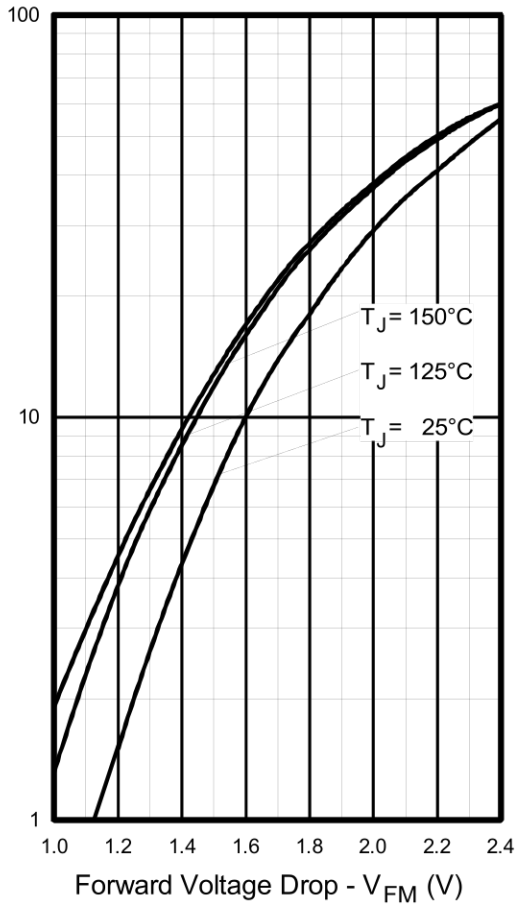

Fig. 1 - Maximum Forward Voltage Drop vs. Instantaneous Forward Current

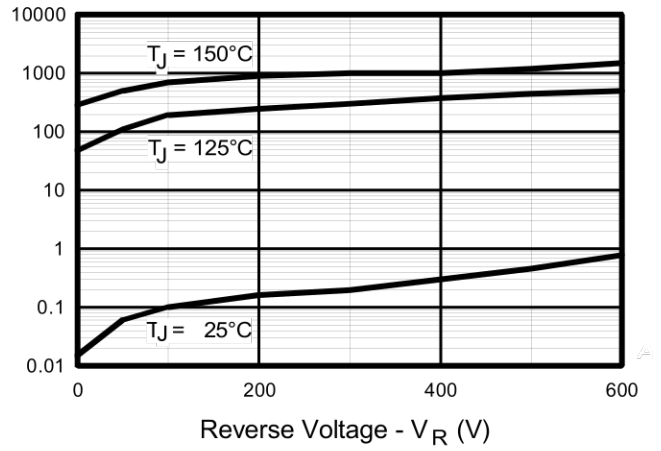

Fig. 2 - Typical Reverse Current vs. Reverse Voltage

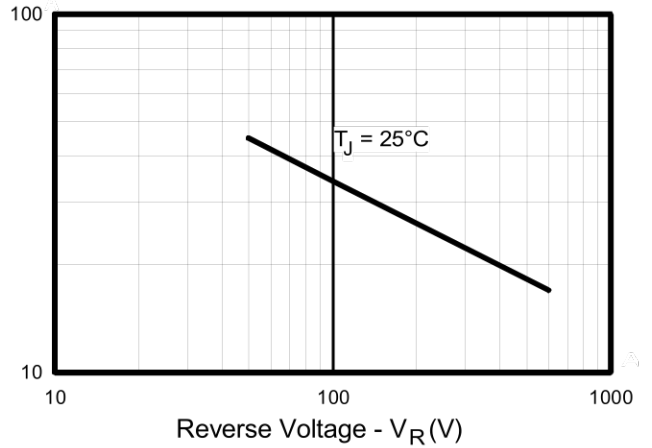

Fig. 3 - Typical Junction Capacitance vs. Reverse Voltage

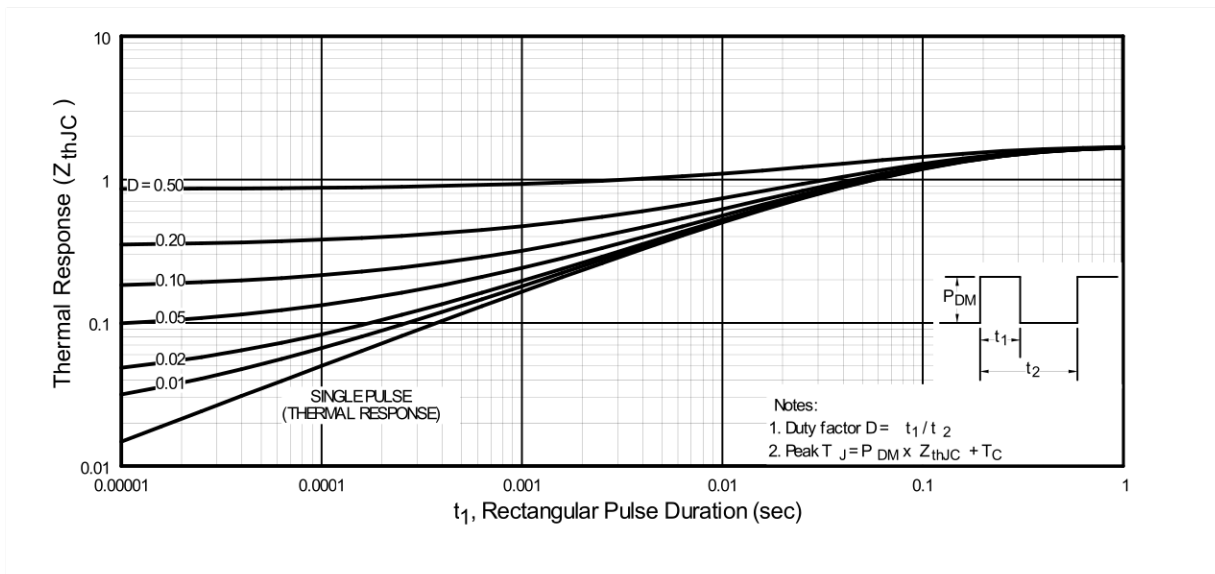

Fig. 4 - Maximum Thermal Impedance Z_{thjc} Characteristics

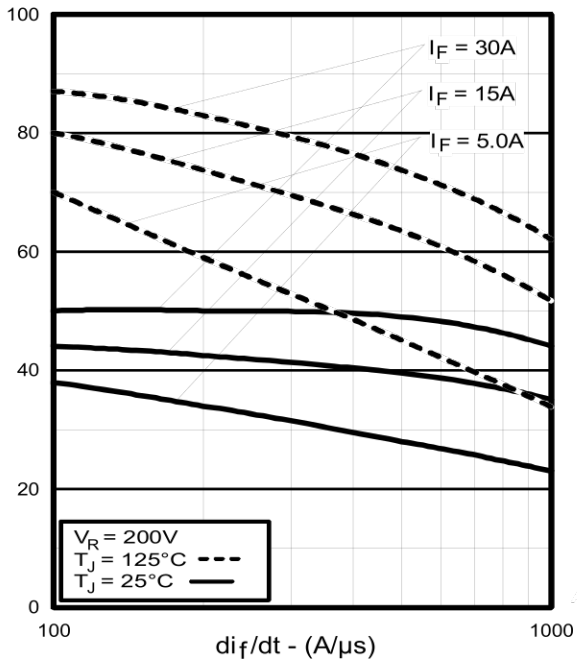

Fig. 5 - Typical Reverse Recovery vs. di_f/dt

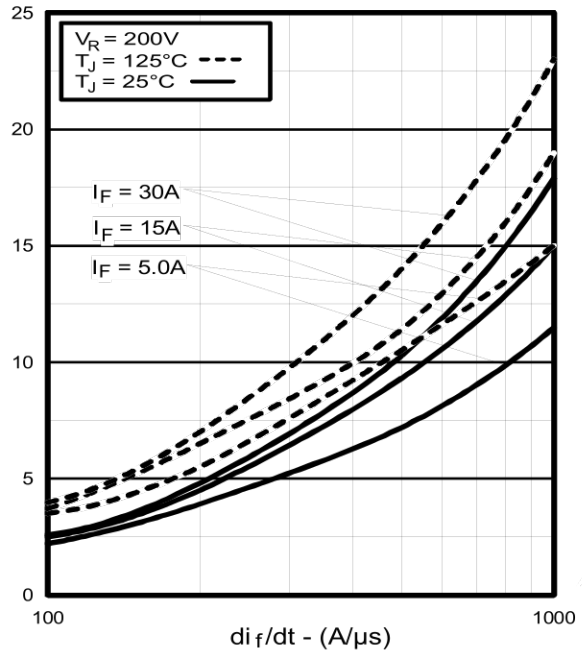

Fig. 6 - Typical Recovery Current vs. di_f/dt

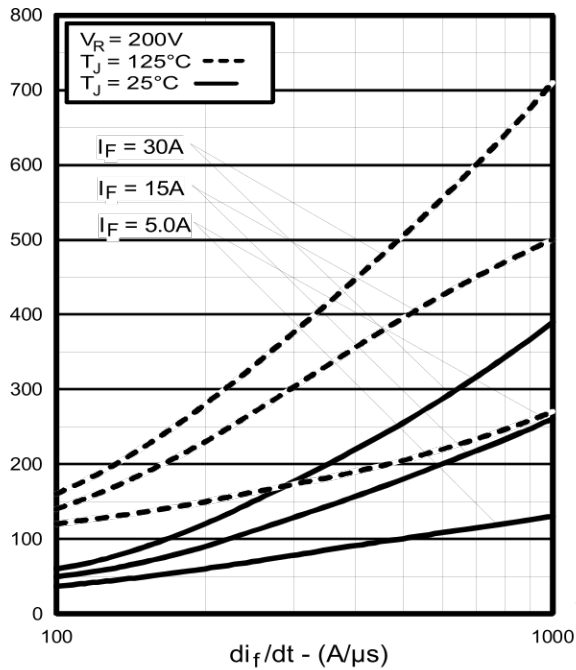

Fig. 7 - Typical Stored Charge vs. di_f/dt

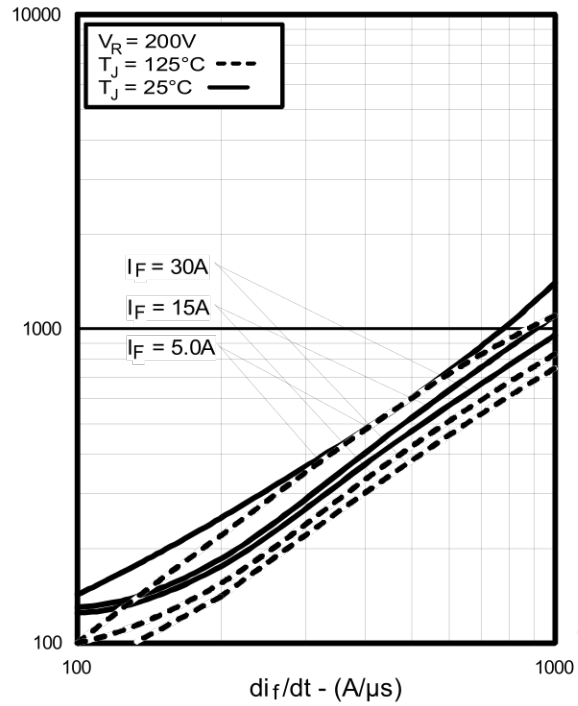
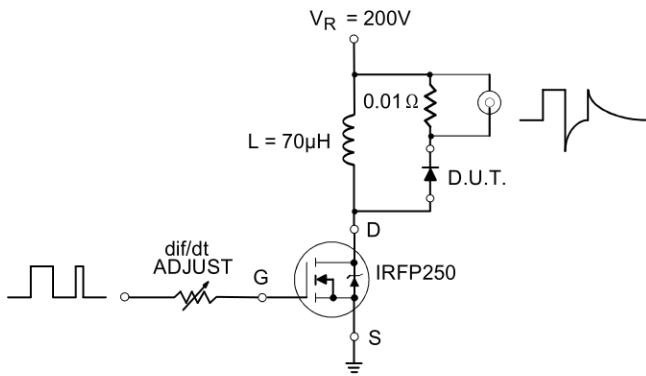
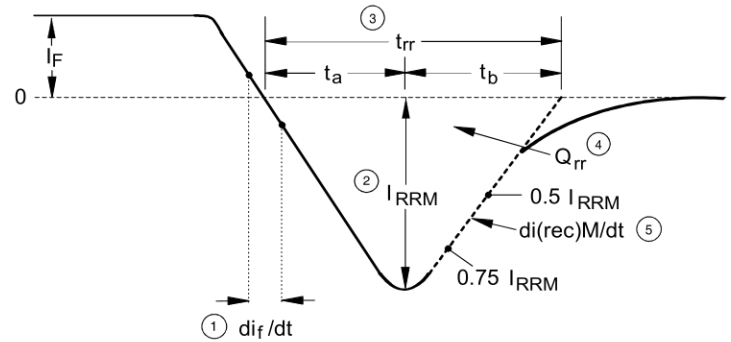

Fig. 8 - Typical $di_{(rec)}M/dt$ vs. di_f/dt

REVERSE RECOVERY CIRCUIT

Fig. 9 - Reverse Recovery Parameter Test Circuit

1. di/dt - Rate of change of current through zero crossing
2. I_{RRM} - Peak reverse recovery current
3. t_{rr} - Reverse recovery time measured from zero crossing point of negative going I_F to point where a line passing through $0.75 I_{RRM}$ and $0.50 I_{RRM}$ extrapolated to zero current

4. Q_{rr} - Area under curve defined by t_{rr} and I_{RRM}

$$Q_{rr} = \frac{t_{rr} \times I_{RRM}}{2}$$

5. $di^{(rec)M}/dt$ - Peak rate of change of current during t_b portion of t_{rr}

Fig. 10 - Reverse Recovery Waveform and Definitions

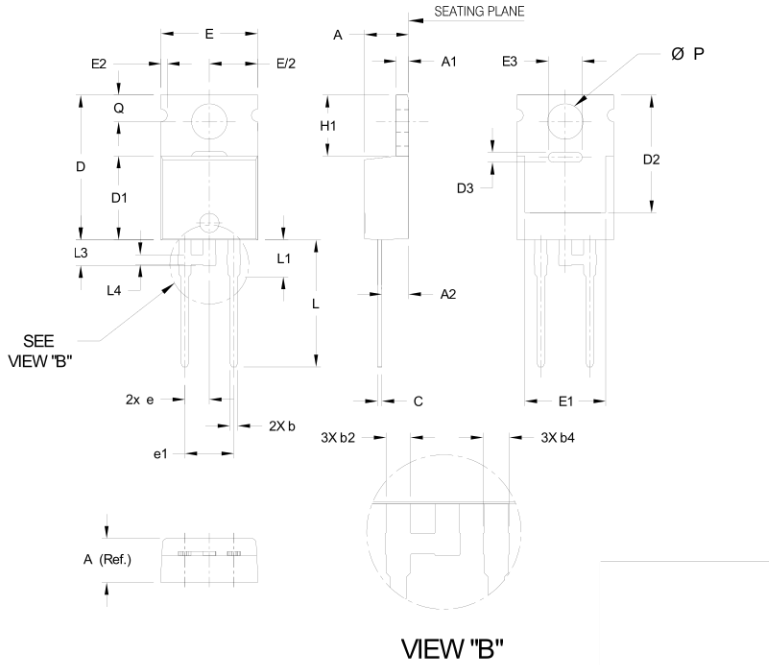
TO-220AC Package Outline (Dimensions are shown in millimeters (inches))

SYMBOL	MIN.	NOM.	MAX.
A	3.56	4.57	4.83
A1	1.14	1.27	1.40
A2	2.03	2.77	2.92
b	0.38	0.81	1.01
b2	1.17	1.27	1.37
b4	1.25	1.35	1.45
c	0.36	0.46	0.61
D	14.32	15.00	16.51
D1	8.38	8.69	9.02
D2	11.68	12.19	12.88
D3	0.82	1.02	1.22
E	9.65	10.00	10.67
E1	6.86	8.39	8.89
E2	--	--	0.76
E3	3.30	3.50	3.70
e	2.54 BASIC		
e1	5.08 BASIC		
H1	5.84	6.31	6.86
L	12.70	13.16	14.73
L1	3.56	3.83	4.06
L3	2.31	2.56	2.81
L4	0.76	1.01	1.27
øP	3.54	3.68	4.08
Q	2.54	2.74	3.42

NOTES:

1. DIMENSIONING AND TOLERANCING AS PER ASME Y14.5M 1994.
2. DIMENSIONS ARE SHOWN IN MILLIMETERS.

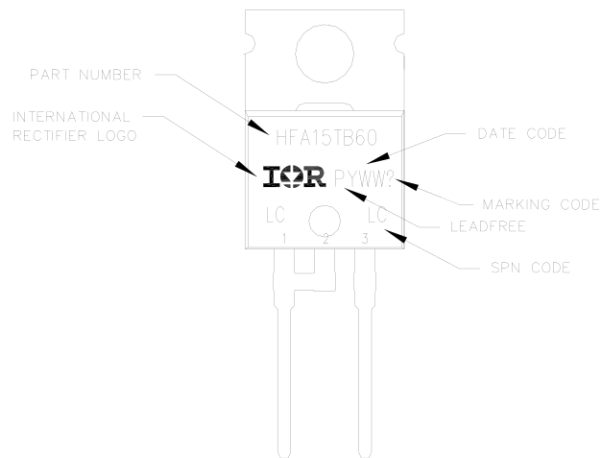
TO-220AC Part Marking Information

Note: For the most current drawing please refer to IR website at <http://www.irf.com/package/>

Qualification Information[†]

Qualification Level	Industrial (per JEDEC JESD47F) ^{††}	
Moisture Sensitivity Level	TO-220AC	N/A
RoHS Compliant	Yes	

† Qualification standards can be found at International Rectifier’s web site: <http://www.irf.com/product-info/reliability/>

†† Applicable version of JEDEC standard at the time of product release.



IR WORLD HEADQUARTERS: 101 N. Sepulveda Blvd., El Segundo, California 90245, USA

To contact International Rectifier, please visit <http://www.irf.com/whoto-call/>