

## General purpose modules

A comprehensive range of chassis mount IEC 60320 inlet power entry modules housed in a compact and lightweight enclosure.

Offers a low cost form of protection from mains borne interference in applications such as business, consumer, medical equipment, VDU's, computers, vending machines and many other general purpose applications.

- Current ratings from 1A to 10A
- Component value combinations to suit requirements
- Low cost design
- Medical versions available

## Mechanical Specifications

Manufacture: metal case with built-in power line connector according to IEC 60320 & EN 60320.

Connections: IEC 60320 - Standard plug (INPUT); faston 2x2.8 x 0.8mm or 6.3 x 0.8mm (OUTPUT); ground terminal connected to case.

## Filter Range

Code	I <sub>R</sub> (A)	L (mH)	C <sub>x</sub> (μF)	C <sub>y</sub> (pF)	I <sub>L</sub> (mA)	Circ Diag
FBNAB2100ZE200	6	2x0.5	0.01	2x2700	2x0.25	A
FBNAB2470ZA100	1	2x2.8	0.047	2x2200	2x0.2	A
FBNAB2470ZB000	1	2x10	0.047	2x2500	2x0.23	A
FBNAB2470ZD000	3	2x2.5	0.047	2x2500	2x0.23	A
FBNAB2470ZF000	6	2x1	0.047	2x2500	2x0.23	A
FBNAB2470ZG110	10	2x0.13	0.047	2x2200	2x0.2	A
FBNAB2680CZ300	3	2x1	0.068	2x3300	2x0.3	B
FBNAB2680ZB000	1	2x10	0.068	2x2500	2x0.23	A
FBNAB2680ZD000	3	2x2.5	0.068	2x2500	2x0.23	A
FBNAB2680ZF000	6	2x1	0.068	2x2500	2x0.23	A
FBNAB3100BZ000	1	2x10	0.01	2x2500	2x0.23	B
FBNAB3100DZ000	3	2x2.5	0.01	2x2500	2x0.23	B
FBNAB3100FZ000	6	2x1	0.01	2x2500	2x0.23	B
FBNAB3100HZ420	3	2x6	0.01	2x150	2x0.014	B

\* other variants on request

**Available Variants**

A = Standard Version  
M = Medical Version (without Y capacitors)

**X Capacitance**  
2100 = 0.010μF  
2470 = 0.047μF  
2680 = 0.068μF  
3100 = 0.1μF

**In, L & CCT.**

CCT A	CCT B	VALUES
ZA	AZ	1A, 2.8mH
ZB	BZ	1A, 10mH
ZC	CZ	3A, 1mH
ZD	DZ	3A, 2.5mH
ZE	EZ	6A, 0.5mH
ZF	FZ	6A, 1mH
ZG	GZ	10A, 0.13mH
ZH	HZ	3A, 6mH

A = 2x2.8mm x 0.8 faston  
B = 6.3mm x 0.8 faston

**Y Capacitance**

Y	Current Leakage
0	2x0.23 mA
1	2x0.20 mA
2	2x0.25 mA
3	2x0.3 mA
4	2x0.014 mA

**Resistor**

Resistor	
0	= no resistor
1	= 1MΩ
2	= 2.2MΩ



## Electrical Specifications

Rated voltage (V<sub>R</sub>): max 250V, 50/60Hz

Rated current (I<sub>R</sub>): referred to room temperature = 40°C

Leakage current (I<sub>L</sub>): at 220V, 50Hz, max value

Voltage test (2 s.): line to ground 3000Vdc or 1800Vac  
line to line 1700Vdc

Climatic category: HMF (25/085/21);

Temperature range: -25°C to +85°C

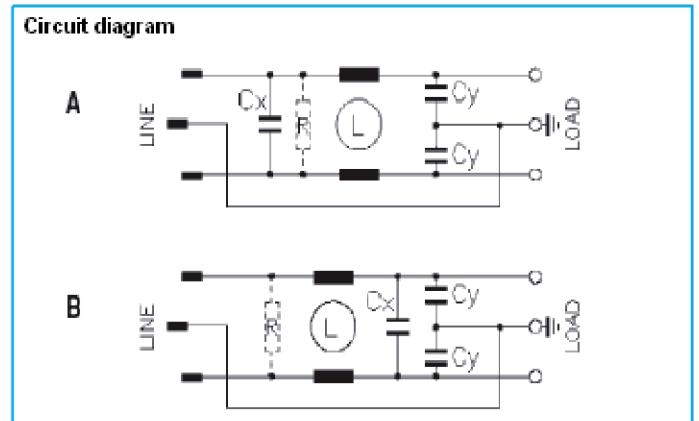
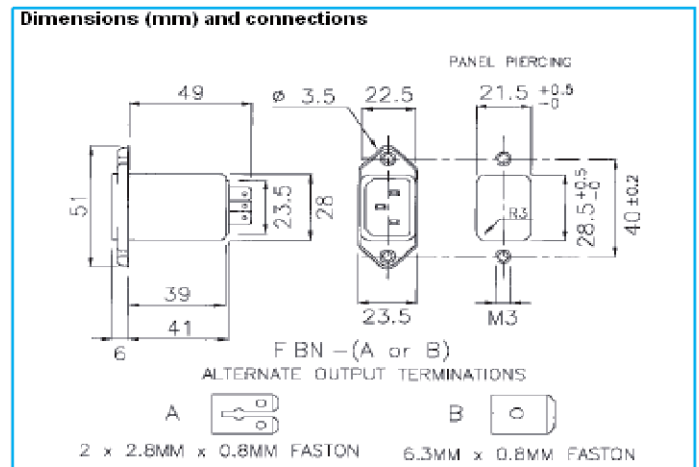

Approvals



1283



22.2 N°8



Insertion loss (typical): — Asymmetrical (line to ground) - - - Symmetrical (line to line)

## FBN

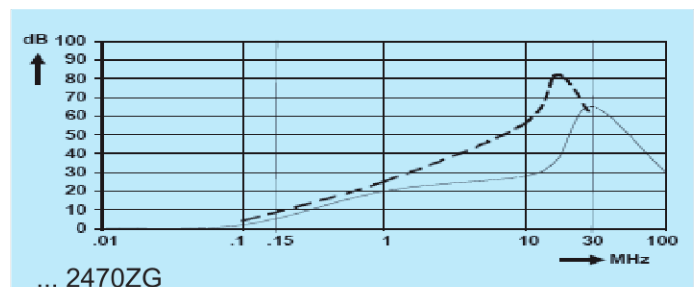
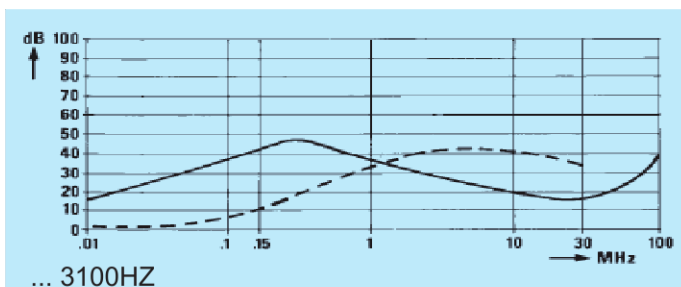
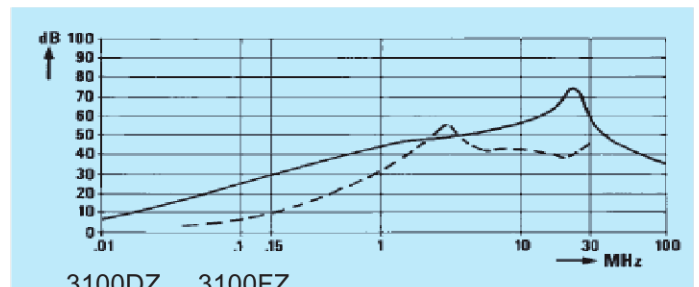
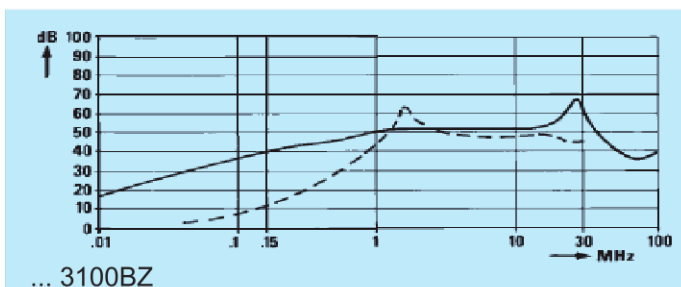
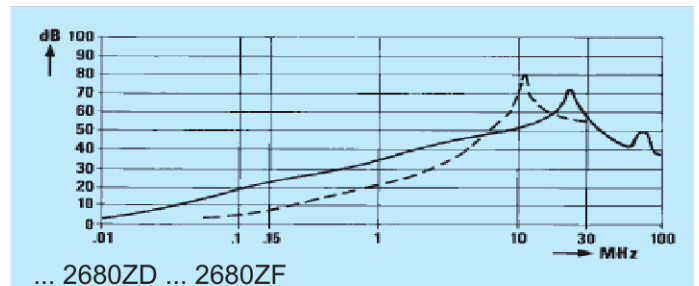
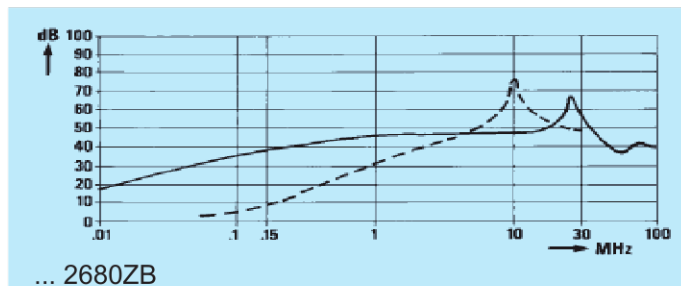
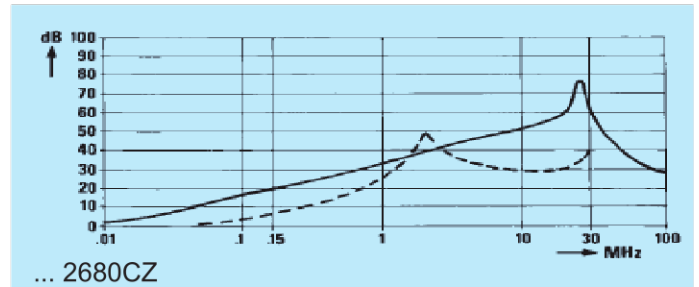
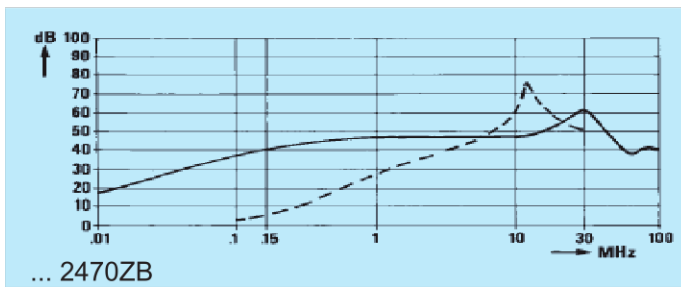
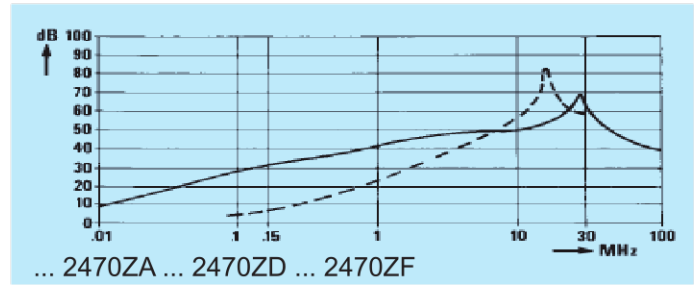
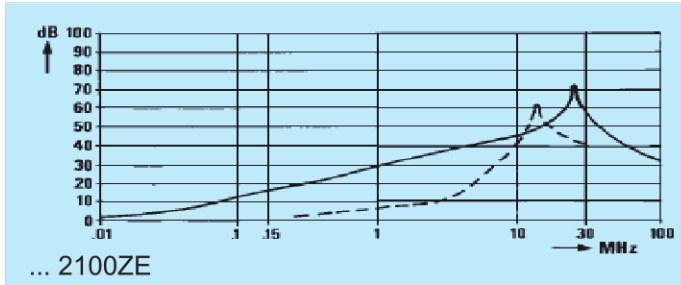

## With fuse holders

A range of chassis mount IEC 60320 inlet power entry modules which combine single or twin fuse holders and a high level of suppression, within a compact and lightweight enclosure.

Cost effective solution for business, consumer, medical equipment, VDUs, computers, vending machines and many other general purpose applications.

- Snap-in or screw fit
- Current ratings from 1A to 10A
- Integral single or twin fuse holder
- Compact, lightweight design
- Medical versions available

## Mechanical Specifications

**Manufacture:** metal case with built-in power line connector according to IEC 60320 & EN 60320 and fuse holder for 1 (FP) or 2 (FQ) fuses 5 x 20mm (IEC).

**Connections:** IEC 60320 - Standard plug (INPUT); faston 2x2.8 x 0.5mm or 6.3 x 0.8mm (OUTPUT); ground terminal connected to case.

**Mounting:** FB- screw mounting; FC- Snap-in mounting.

## Filter Range

Code	I <sub>R</sub> (A)	L (mH)	C <sub>x1</sub> (μF)	C <sub>y</sub> (pF)	I <sub>L</sub> (mA)
F - AB2680ZA100	1	2x10	0.068	2x2200	2x0.2
F - AB2680ZB100	2	2x4	0.068	2x2200	2x0.2
F - AB2680ZC100	4	2x1.5	0.068	2x2200	2x0.2
F - AB2680ZF100	6	2x0.8	0.068	2x2200	2x0.2
F - AB2680ZG100	10	2x0.13	0.068	2x2200	2x0.2

\* other variants on request

## Available Variants

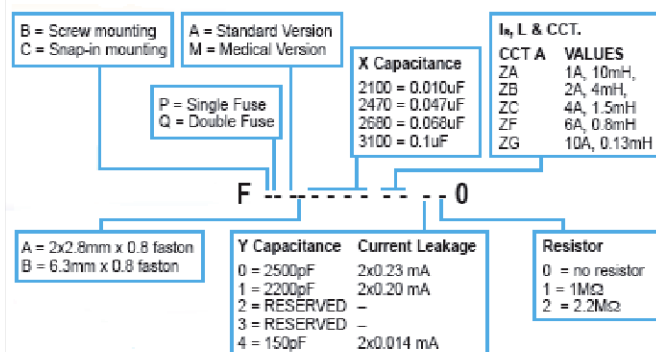

## Electrical Specifications

Rated voltage (V<sub>R</sub>): max 250V, 50/60Hz

Rated current (I<sub>R</sub>): referred to room temperature = 40°C

Leakage current (I<sub>L</sub>): at 220V, 50Hz, max value

Voltage test (2 s.): line to ground 3000Vdc or 1800Vac  
line to line 1700Vdc

Climatic category: HMF (25/085/21);

Temperature range: -25°C to +85°C

## Circuit diagram

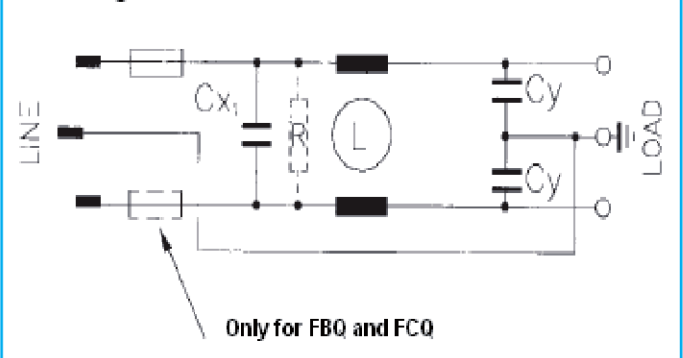

**FBP - FBQ - FCP - FCQ**

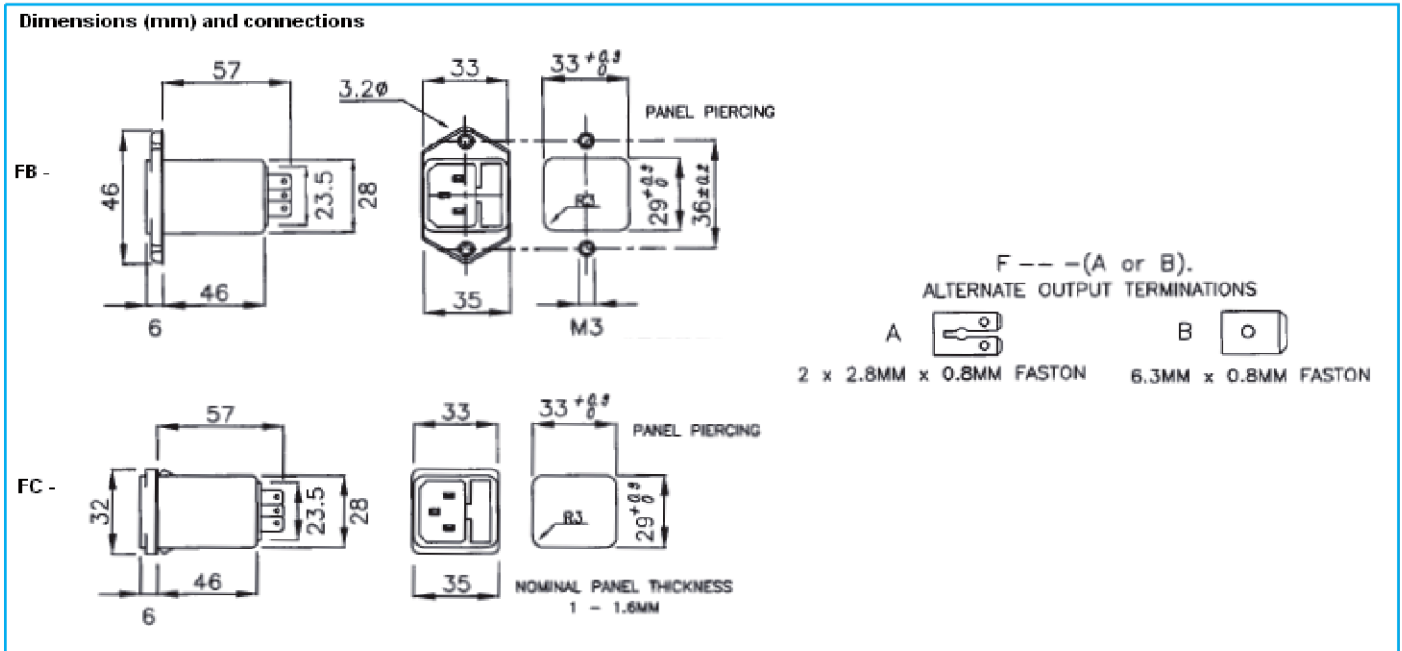

Insertion loss (typical): — Asymmetrical (line to ground) - - - Symmetrical (line to line)

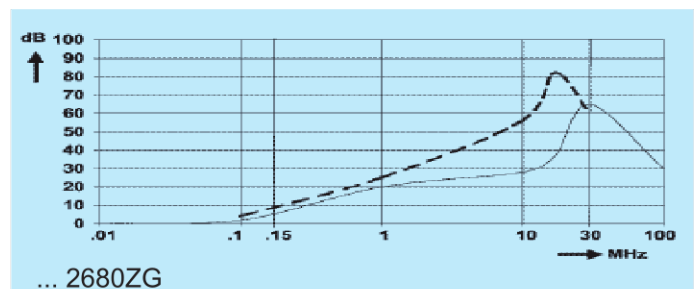
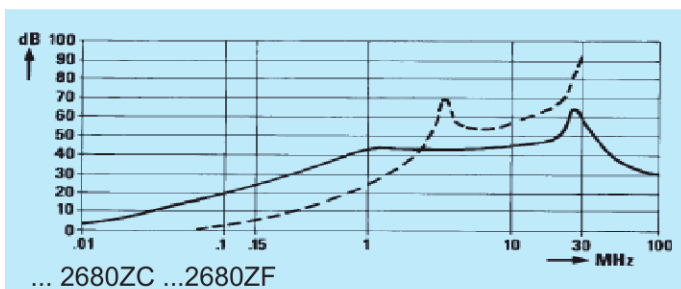
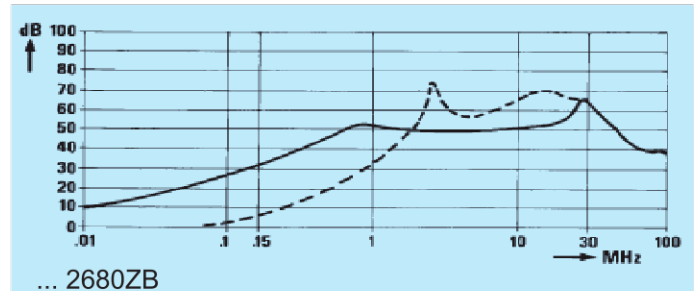
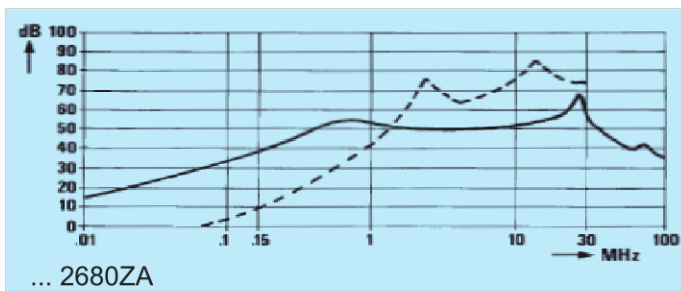



## High current modules

Compact, high current chassis mount IEC 60320 inlet power entry module, available in standard of medical design formats.

The unit provides excellent performance to size characteristics for use in a variety of higher power applications, from industrial equipment and telecoms base stations to test instrumentation and vending machines.

- High current rating - 16A
- High performance to size ratio
- Compact and lightweight
- Medical versions available
- IEC 950 compliant

## Mechanical Specifications

Manufacture: metal case with built-in power line connector according to IEC 60320 & EN 60320.

Connections: IEC 60320 - 16A plug (INPUT);  
6.3 x 0.8mm (OUTPUT);  
ground terminal connected to case.

## Filter Range

Code	$I_R$ (A)	L (mH)	$C_x$ ( $\mu$ F)	$C_y$ (pF)	$I_L$ (mA)
FBNAB3330ZJ110	16	2x0.5	0.33	2x2200	2x0.2
FBNMB3330ZJ110	16	2x0.5	0.33	-	-

A = Standard version  
M = Medical version

\* other variants on request

Insertion loss (typical): — Asymmetrical (line to ground)  
--- Symmetrical (line to line)

## FBN 16A type

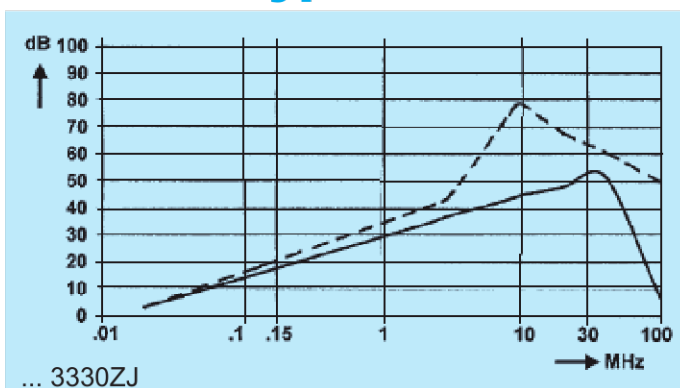

## Electrical Specifications

Rated voltage ( $V_R$ ): max 250V, 50/60Hz

Rated current ( $I_R$ ): referred to room temperature = 40°C

Leakage current ( $I_L$ ): at 250V, 50Hz, max value

Voltage test (2 s.): line to ground 3000Vdc or 1800Vac  
line to line 1700Vdc

Climatic category: HMF (25/085/21);

Temperature range: -25°C to +85°C

## Dimensions (mm) and connections

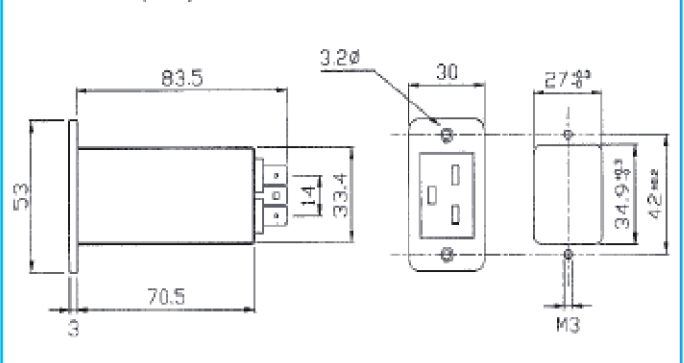

## Circuit diagram

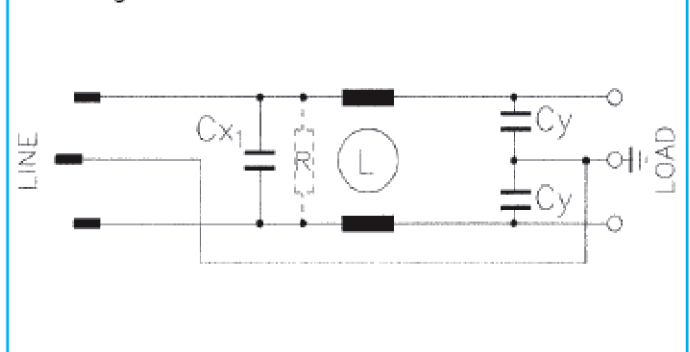

## Approvals

Made in accordance to VDE, UL and CSA requirements