

THIS DOCUMENT IS THE PROPERTY OF  
KEYSTONE ELECTRONICS CORP. AND  
SHALL NOT BE REPRODUCED, DISTRIBUTED  
OR USED AS A BASIS FOR MANUFACTURE  
WITHOUT PRIOR WRITTEN PERMISSION  
FROM KEYSTONE ELECTRONICS CORP.

REQUIRED SPACING FOR 'AA' CLIP

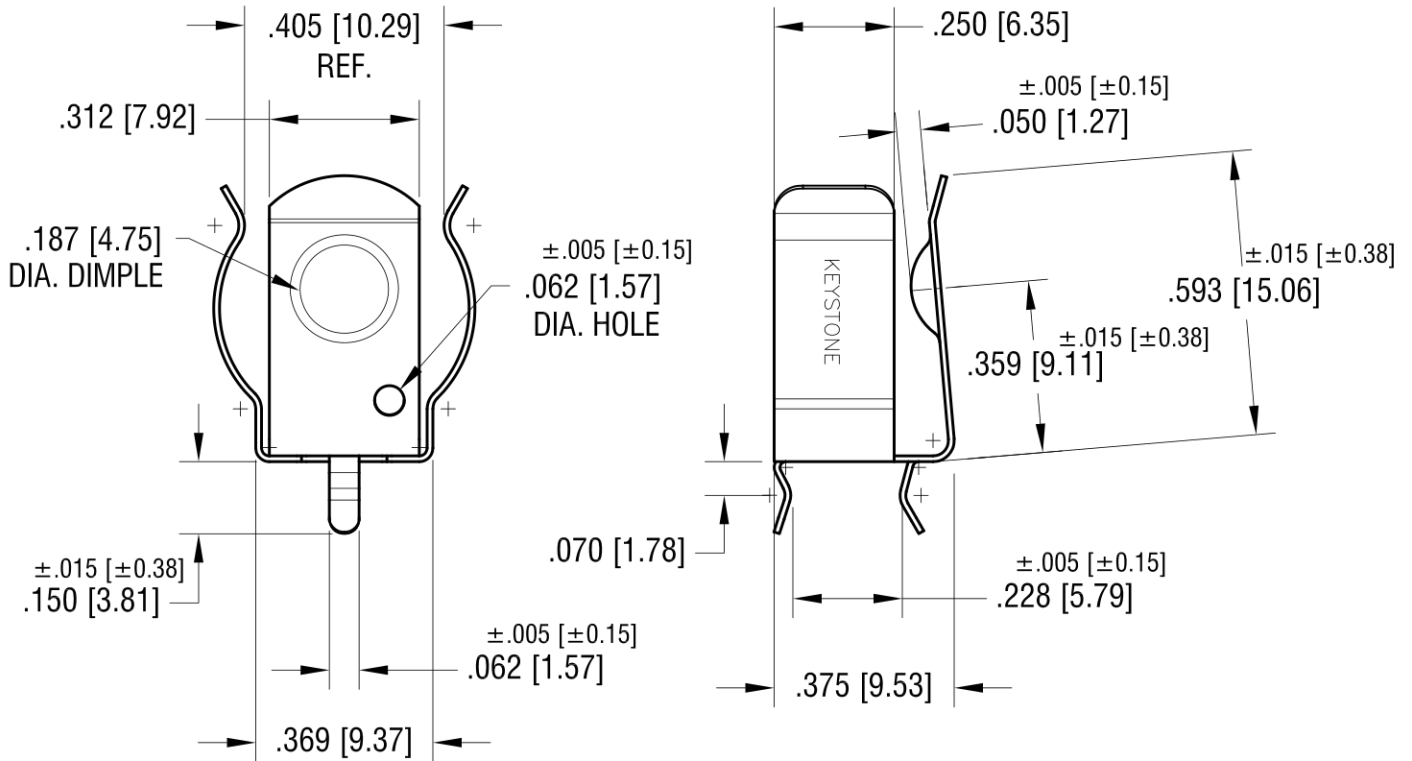
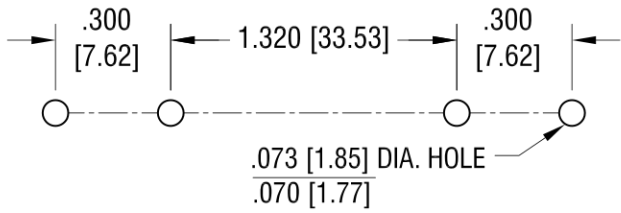

NOTE:  
1. HEAT TREAT TO SPRING TEMPER.

DATE	DESCRIPTION	REV.
9.06.16	CHANGE AS PER ECR 16-065	N
9.01.16	CHANGE AS PER ECN16-083	M
7.11.14	CHANGE AS PER ECN14-065	L
6.19.06	CHANGE AS PER ECN 06-038	K

<b>KEYSTONE ELECTRONICS CORP.</b>			
www.keyelco.com • NEW HYDE PARK, NY 11040 • Tel (516) 328-7500			
PART NAME		'CR2' & 'AA' PC BATTERY CLIP	
MATERIAL		.012 [0.30] TH'K ANNEALED SPRING STEEL	
FINISH		DRN BY	DATE
TIN NICKEL PLATE		BOONE	4.28.89
		APP'D	SCALE
		RH	2.5X
TOLERANCES	INCH [MM]	CODE	DWG NO.
DECIMAL	± .010 [± 0.25]	C	<b>92</b>
ANGULAR	± 2°		
UNLESS OTHERWISE SPECIFIED			