

FEATURES

- **Guaranteed** $\pm 4\text{mV}$ Initial Accuracy LT1004-1.2
- **Guaranteed** $\pm 20\text{mV}$ Accuracy LT1004-2.5
- **Guaranteed** $10\mu\text{A}$ Operating Current
- **Guaranteed** Temperature Performance
- Operates up to 20mA
- Very Low Dynamic Impedance

APPLICATIONS

- Portable Meter References
- Portable Test Instruments
- Battery-Operated Systems
- Current Loop Instrumentation

DESCRIPTION

The LT[®]1004 micropower voltage reference is a 2-terminal bandgap reference diode designed to provide high accuracy and excellent temperature characteristics at very low operating currents. Optimization of the key parameters in the design, processing and testing of the device results in accuracy specifications previously attainable only with selected units. Below is a distribution plot of reference voltage for a typical lot of LT1004-1.2. Virtually all of the units fall well within the prescribed limits of $\pm 4\text{mV}$.

The LT1004 is a pin-for-pin replacement for the LM185/LM385 series of references with improved accuracy specifications. More important, the LT1004 is an attractive device for use in systems where accuracy was previously obtained at the expense of power consumption and trimming.

For a low drift micropower reference with guaranteed temperature coefficient, see the LT1034 data sheet.

 LTC and LT are registered trademarks of Linear Technology Corporation.

TYPICAL APPLICATION

Micropower Cold Junction Compensation for Thermocouples

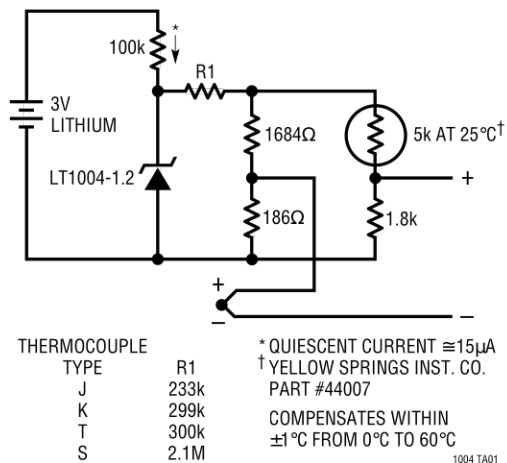

Typical Distribution of
 Reference Voltage (LT1004-1.2)

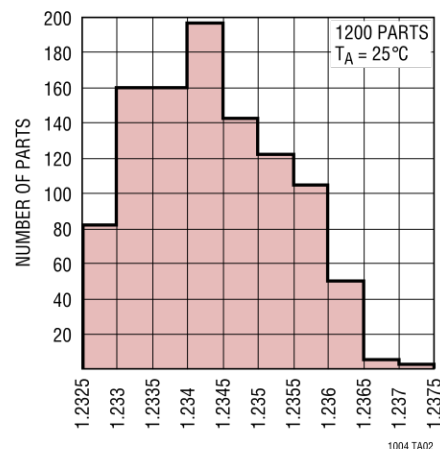

LT1004

ABSOLUTE MAXIMUM RATINGS (Note 1)

Reverse Breakdown Current	30mA	Operating Temperature Range	
Forward Current	10mA	LT1004M (OBSOLETE)	-55°C to 125°C
Storage Temperature Range	-65°C to 150°C	LT1004I	-40°C to 85°C
Lead Temperature (Soldering, 10 sec)	300°C	LT1004C	0°C to 70°C

PACKAGE/ORDER INFORMATION

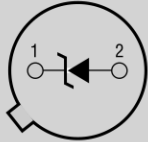
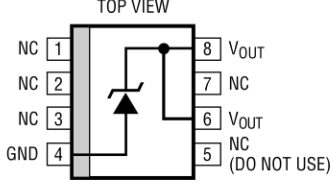
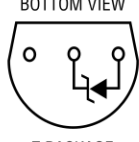
 <p>BOTTOM VIEW</p> <p>H PACKAGE 2-LEAD TO-46 METAL CAN $T_{JMAX} = 150^{\circ}C, \theta_{JA} = 440^{\circ}C/W, \theta_{JC} = 80^{\circ}C/W$</p>	 <p>TOP VIEW</p> <p>S8 PACKAGE 8-LEAD PLASTIC SO $T_{JMAX} = 100^{\circ}C, \theta_{JA} = 150^{\circ}C/W$</p>	 <p>BOTTOM VIEW</p> <p>Z PACKAGE 3-LEAD PLASTIC TO-92 $T_{JMAX} = 100^{\circ}C, \theta_{JA} = 160^{\circ}C/W$</p>	
ORDER PART NUMBER	ORDER PART NUMBER	S8 PART MARKING	ORDER PART NUMBER
LT1004MH-1.2 LT1004CH-1.2 LT1004MH-2.5 LT1004CH-2.5 OBSOLETE PACKAGE <small>Consider the SO-8 or Z Packages for Alternate Source</small>	LT1004CS8-1.2 LT1004CS8-2.5 LT1004IS8-1.2 LT1004IS8-2.5	0412 0425 0412I 0425I	LT1004CZ-1.2 LT1004CZ-2.5 LT1004IZ-1.2 LT1004IZ-2.5

Consult LTC Marketing for parts specified with wider operating temperature ranges.

ELECTRICAL CHARACTERISTICS

The ● denotes the specifications which apply over the full operating temperature range, otherwise specifications are at $T_A = 25^{\circ}C$. (Note 2)

SYMBOL	PARAMETER	CONDITIONS	LT1004-1.2			LT1004-2.5			UNITS
			MIN	TYP	MAX	MIN	TYP	MAX	
V_Z	Reverse Breakdown Voltage	$I_R = 100\mu A$	1.231	1.235	1.239	2.480	2.500	2.520	V
		● LT1004M: $-55^{\circ}C \leq T_A \leq 125^{\circ}C$	1.220	1.230	1.245	2.460	2.500	2.535	V
		● LT1004C: $0^{\circ}C \leq T_A \leq 70^{\circ}C$	1.225	1.235	1.245	2.470	2.500	2.530	V
		● LT1004I: $-40^{\circ}C \leq T_A \leq 85^{\circ}C$	1.220	1.230	1.245	2.460	2.500	2.530	V
$\frac{\Delta V_Z}{\Delta Temp}$	Average Temperature Coefficient	$I_{MIN} \leq I_R \leq 20mA$ (Note 3)	20			20			ppm/°C
I_{MIN}	Minimum Operating Current		● 8 10			12 20			μA
$\frac{\Delta V_Z}{\Delta I_R}$	Reverse Breakdown Voltage Change with Current	$I_{MIN} \leq I_R \leq 1mA$	● 1.0			1.0			mV
			● 1.5			1.5			mV
		$1mA \leq I_R \leq 20mA$	● 10			10			mV
r_Z	Reverse Dynamic Impedance	$I_R = 100\mu A$	● 0.2 0.6			0.2 0.6			Ω
			● 1.5			1.5			Ω
e_n	Wide Band Noise (RMS)	$I_R = 100\mu A, 10Hz \leq f \leq 10kHz$	60			120			μV
$\frac{\Delta V_Z}{\Delta Time}$	Long Term Stability	$I_R = 100\mu A, T_A = 25^{\circ}C \pm 0.1^{\circ}C$	20			20			ppm/kHr

Note 1: Absolute Maximum Ratings are those values beyond which the life of a device may be impaired.

Note 2: All specifications are for $T_A = 25^{\circ}C$ unless otherwise noted.

Note 3: Selected devices with guaranteed maximum temperature coefficient are available upon request.

For MIL-STD components, please refer to LTC 883C data sheet for test listing and parameters.

TYPICAL PERFORMANCE CHARACTERISTICS (1.2V)

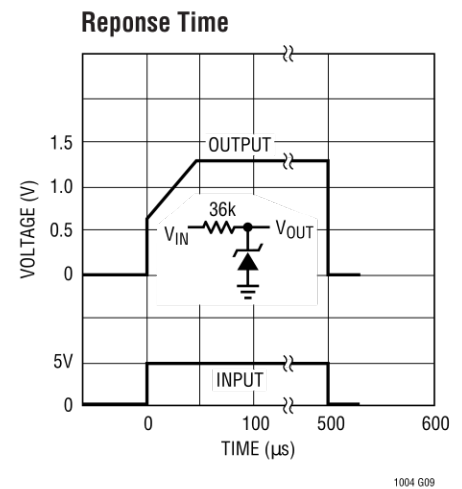
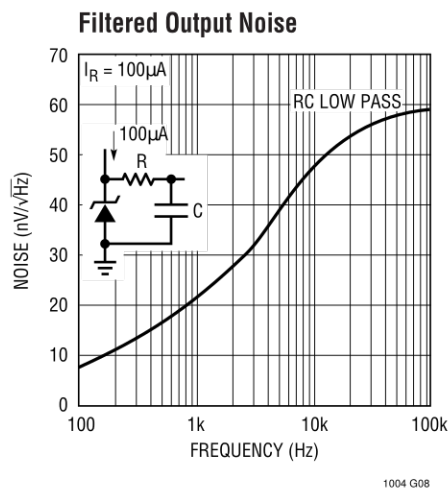
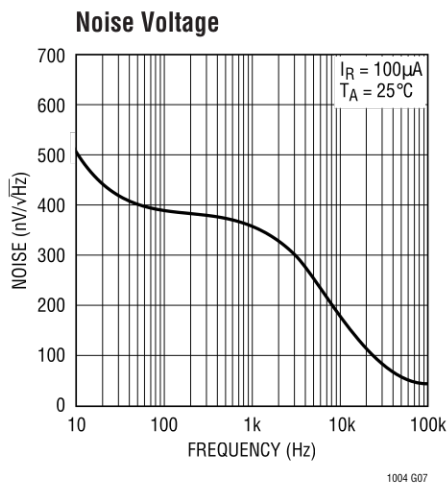
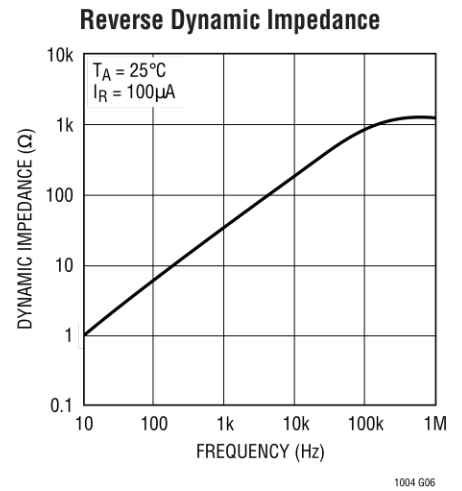
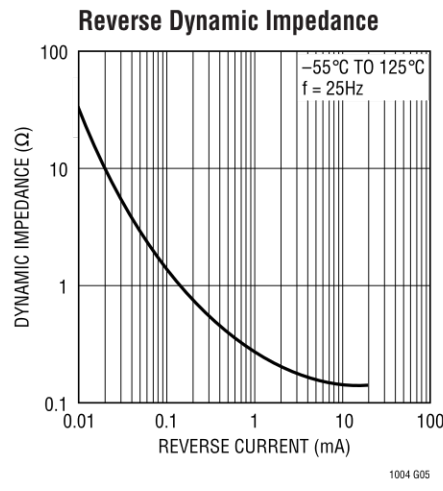
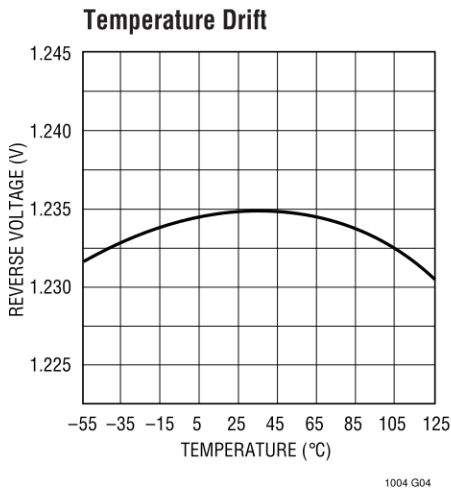
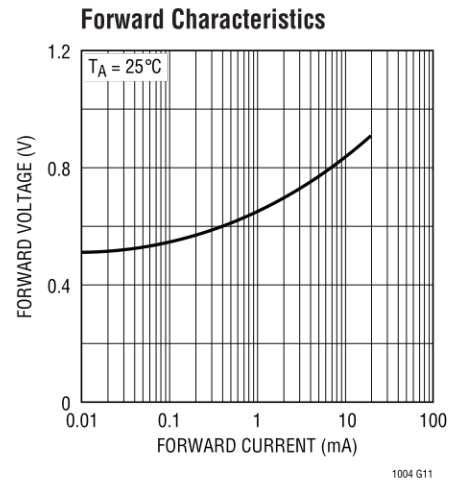
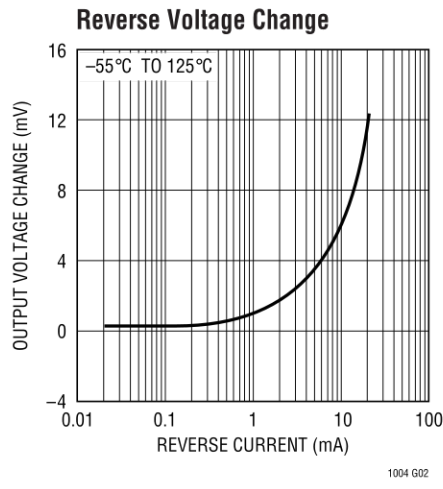
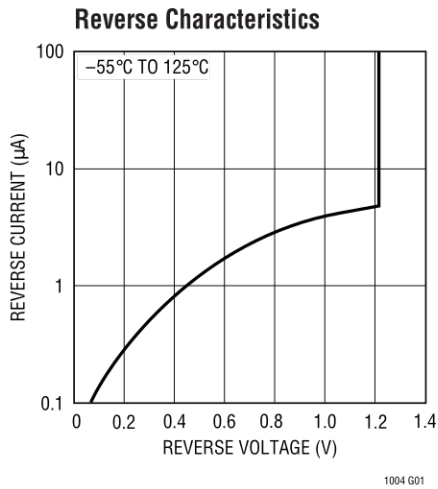

TYPICAL PERFORMANCE CHARACTERISTICS (2.5V)

Reverse Characteristics

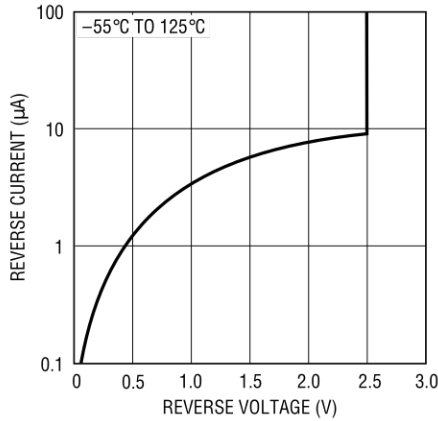

1004 G10

Forward Characteristics

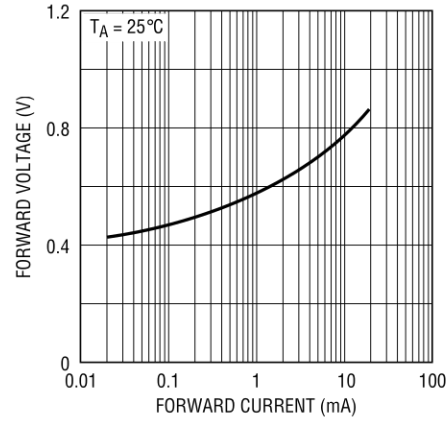

1004 G11

Temperature Drift

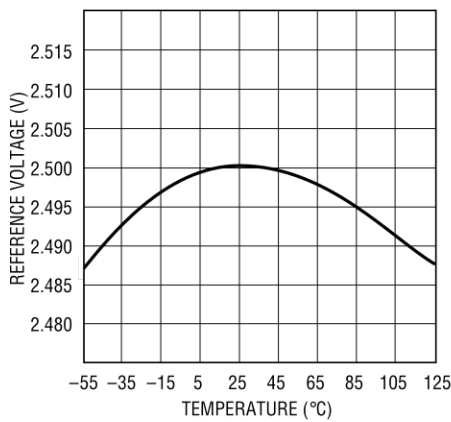

1004 G12

Reverse Dynamic Impedance

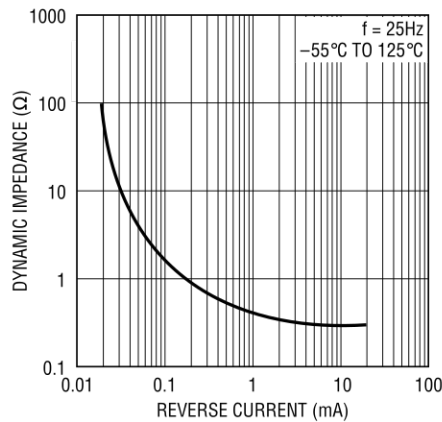

1004 G13

Reverse Dynamic Impedance

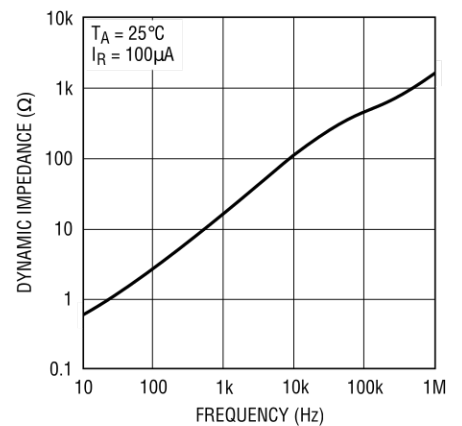

1004 G14

Noise Voltage

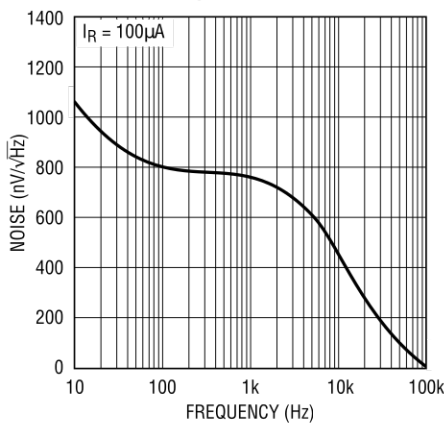

1004 G15

Filtered Output Noise

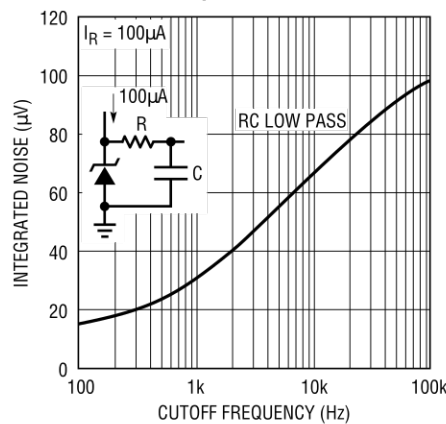

1004 G16

Reponse Time

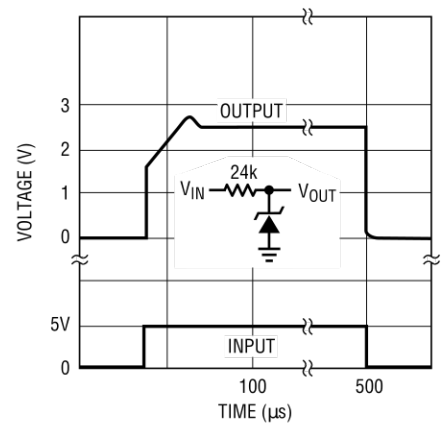

1004 G17

TYPICAL APPLICATIONS

High Stability 5V Regulator

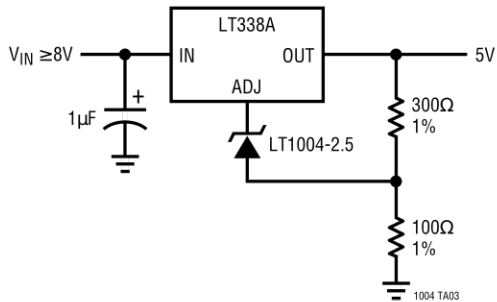

Variable Output Supply

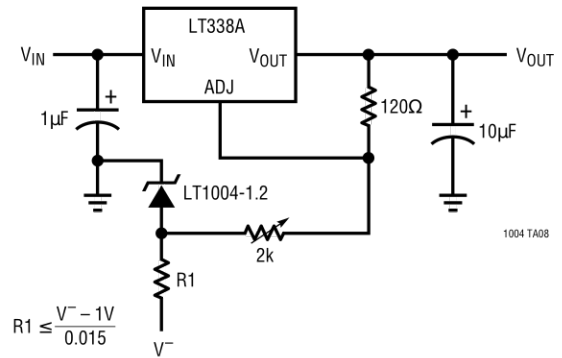

Constant Gain Amplifier Over Temperature

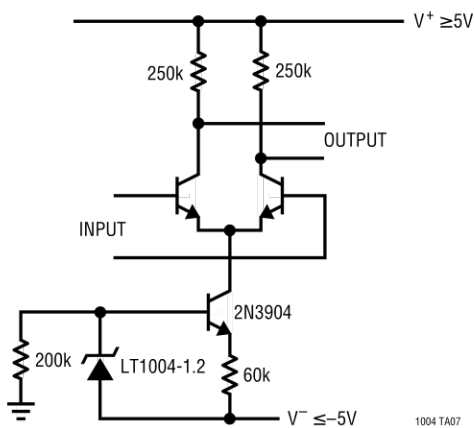

Micropower 5V Reference

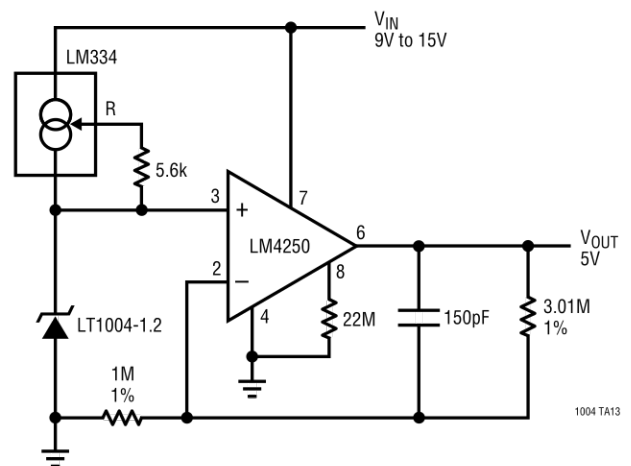

Lead Acid Low-Battery Detector

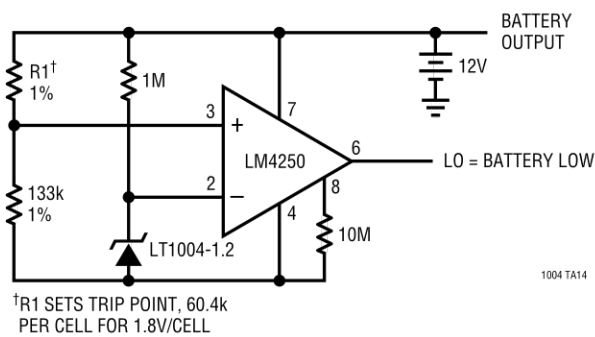

Ground Referenced Current Source

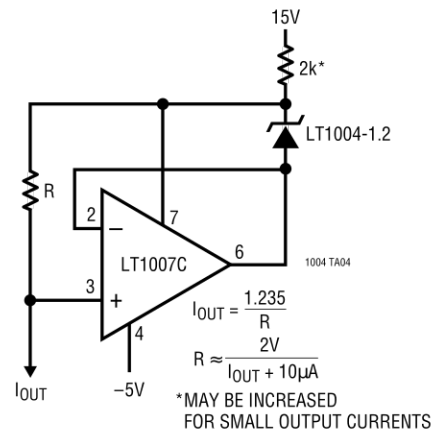

TYPICAL APPLICATIONS

VPP Generator for Eeproms — No Trim Required

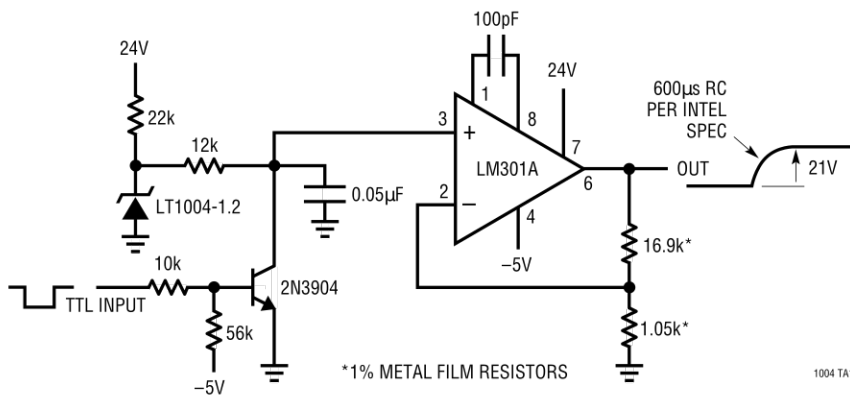

1.2V Reference from 1.5V Battery

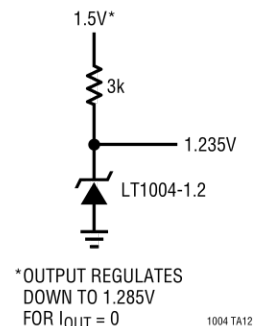

Micropower Reference from 9V Battery

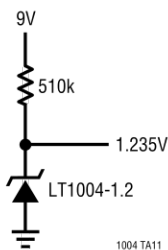

2.5V Reference

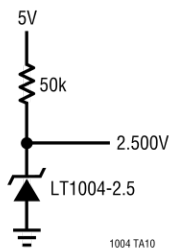

Low Noise Reference

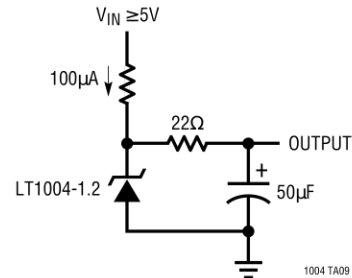

SCHEMATIC DIAGRAMS

LT1004-1.2

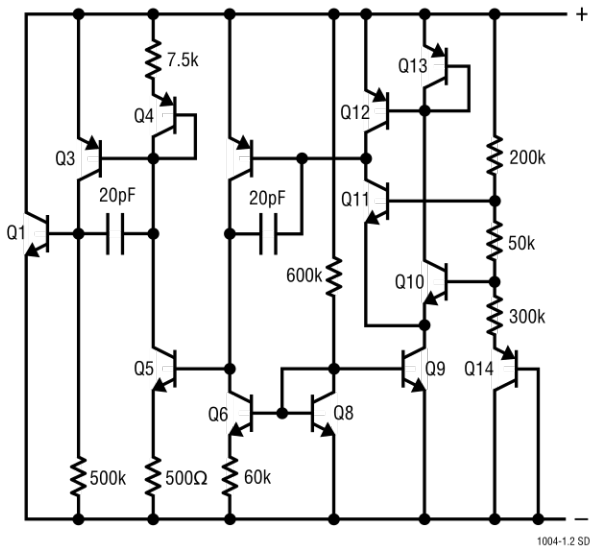

LT1004-2.5

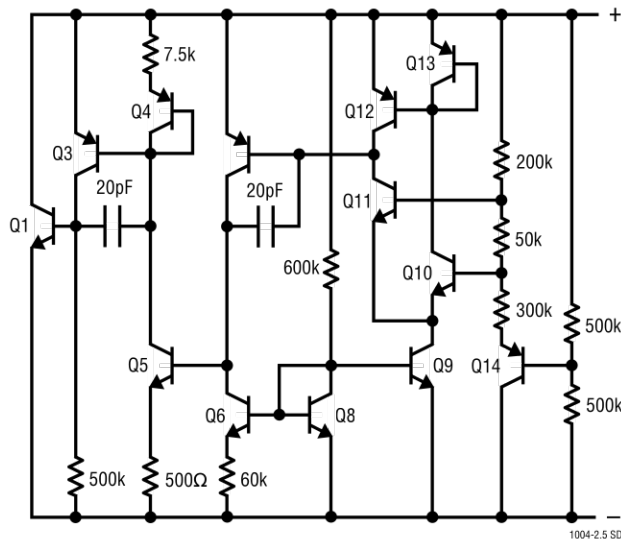

PACKAGE DESCRIPTION

H Package 2-Lead and 3-Lead TO-46 Metal Can (Reference LTC DWG # 05-08-1340)

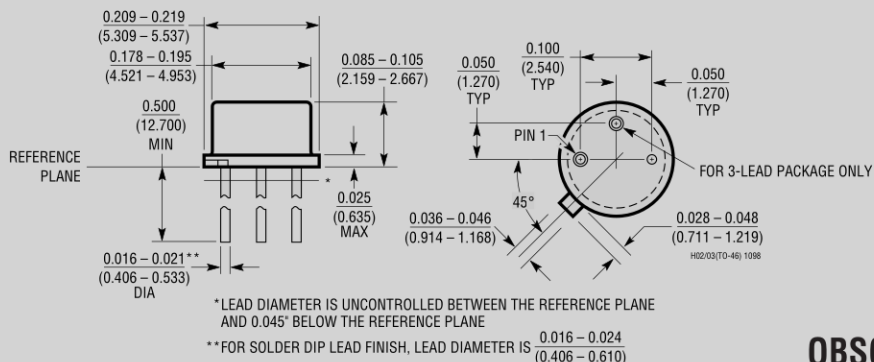

OBsolete PACKAGE

S8 Package 8-Lead Plastic Small Outline (Narrow .150 Inch) (Reference LTC DWG # 05-08-1610)

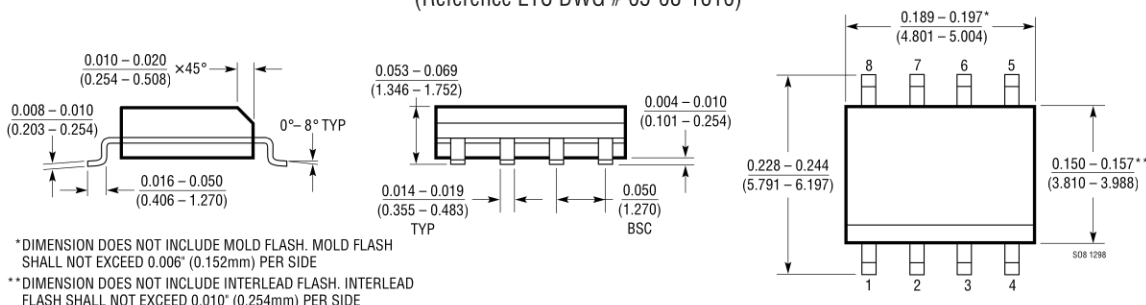

Z Package 3-Lead Plastic TO-92 (Similar to TO-226) (Reference LTC DWG # 05-08-1410)

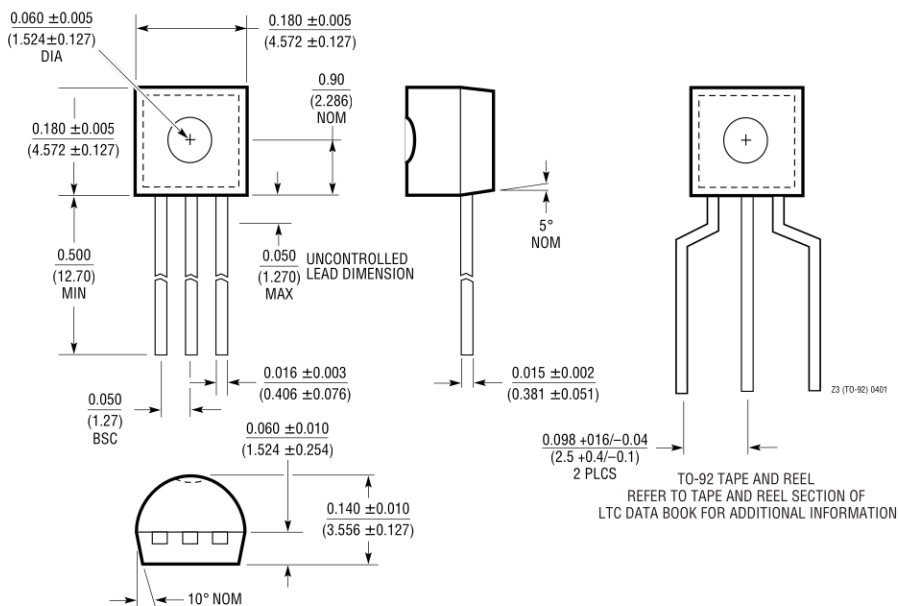

TYPICAL APPLICATIONS

0°C to 100°C Linear Output Thermometer

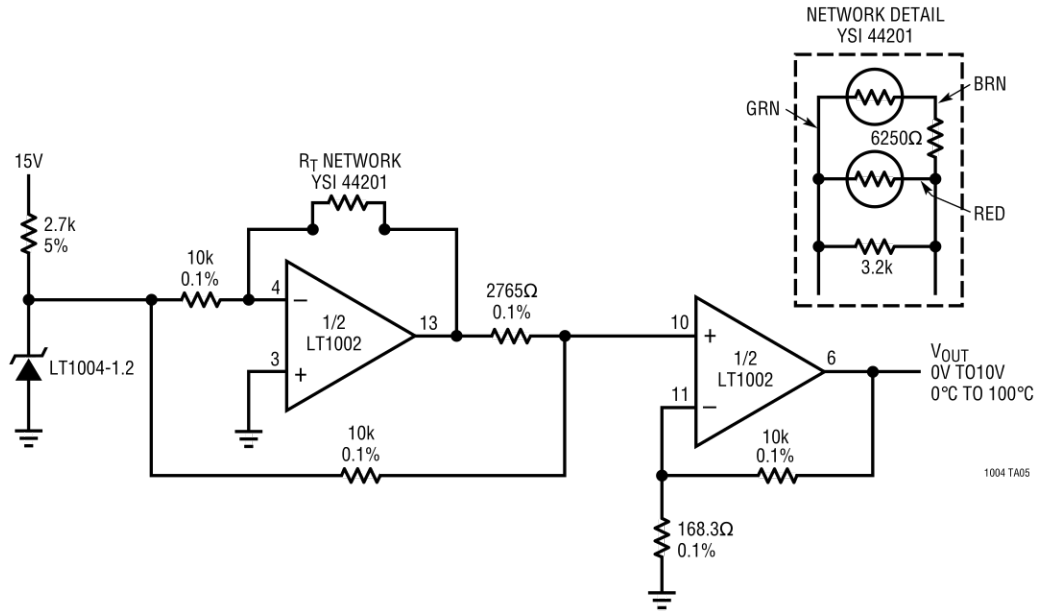

Low Temperature Coefficient 2-Terminal Current Source

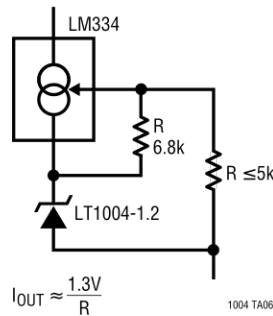

RELATED PARTS

PART NUMBER	DESCRIPTION	COMMENTS
LT1634	Micropower Precision Shunt Reference	10µA Operating Current, 10ppm/°C Maximum Drift, 0.05% Initial Accuracy
LT1460S3-2.5	Micropower Series Reference in SOT-23	100µA Operating Current, 20ppm/°C Maximum Drift, 0.2% Initial Accuracy
LT1790	Precision Micropower LDO Reference in SOT-23	10ppm/°C Max Drift, 0.05% Initial Accuracy