

KSK-1A87 Reed Switches

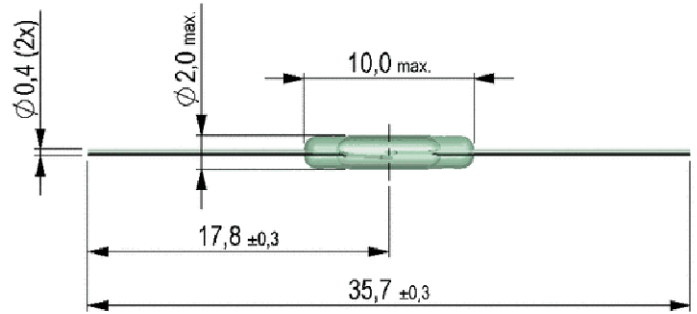

- Features: Miniature, Long Life
- Applications: Rotary Detection, Level Sensor, Metering & Others
- Markets: Fluid Flow, Test & Measurement, Automotive & Others

Part Description: **K S K - 1 A 8 7 X X X X**

Contact QTY	Contact Form	Switch Model	Pull-In Excitation (AT-Range)
1	A (SPST-NO)	87	10 - 45

Contact Data		Unit
Rated Power (max.) Any DC combination of V&A not to exceed their individual max.'s	10	W
Switching Voltage (max.) DC or peak AC	200	V
Switching Current (max.) DC or peak AC	0.4	A
Carry Current (max.) DC or peak AC	0.5	A
Contact Resistance (max.) @ 0.5V & 10mA	150	mOhm
Breakdown Voltage (min.) DC or peak AC	230	V
Operating Time (max.) Incl. Bounce; Measured with 40% Overdrive	0.6	ms
Release Time (max.) Measured with no Coil Excitation	0.1	ms
Test Coil	KMS-01	
Insulation Resistance (min.) RH < 45%, 100 V Test Voltage	10 ⁹	Ohm
Capacitance (typ.) @ 10kHz across open Switch	0.2	pF

Series Datasheet – KSK-1A87 Reed Switches

www.standexmeder.com

Dimensions (mm)	
Overall Length (max.)	35.7
Glass Length (max.)	10.0
Glass Dia (max.)	2.0
Lead Dia. (max.)	0.4

Environmental Data		Unit
Shock Resistance (max.) 1/2 sine wave duration 11ms	50	g
Vibration Resistance (max.)	20	g
Operating Temperature	-40 to 130	°C
Storage Temperature	-55 to 130	°C
Soldering Temperature (max.) 5 sec. max.	260	°C

KSK-1A87 Reed Switch



Handling & Assembly Instructions	
➤	Use proper lead clamping or heat sinking techniques to prevent mechanical and/or heat stress to the glass seal during bending, cutting, soldering, and welding
➤	Mechanical shock as the result of dropping the reed switch typically from a distance of greater than 12" may change it's magnetic sensitivity and/or destroy the switch
➤	Any form of modification to the switch leads will alter it's magnetic sensitivity
➤	Series resistor recommended for >5m cable length

Life Test Data

*Load increase reduces life expectancy of Reed Switches

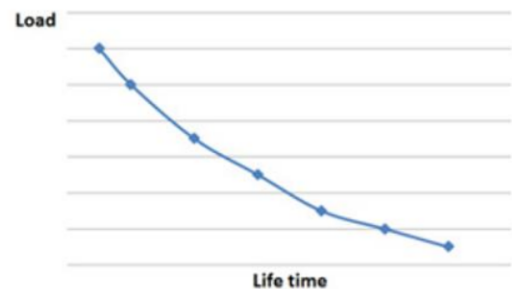

Glossary Contact Form		
Form A	NO = Normally Open Contacts SPST = Single Pole Single Throw	
Form B	NC = Normally Closed Contacts SPST = Single Pole Single Throw	
Form C	Changeover SPDT = Single Pole Double Throw	

