

## LM107/LM207/LM307 Operational Amplifiers

### General Description

The LM107 series are complete, general purpose operational amplifiers, with the necessary frequency compensation built into the chip. Advanced processing techniques make the input currents a factor of ten lower than industry standards like the 709. Yet, they are a direct, plug-in replacement for the 709, LM101A and 741.

The LM107 series offers the features of the LM101A, which makes its application nearly foolproof. In addition, the device provides better accuracy and lower noise in high impedance circuitry. The low input currents also make it particularly well suited for long interval integrators or timers, sample and hold circuits and low frequency waveform genera-

tors. Further, replacing circuits where matched transistor pairs buffer the inputs of conventional IC op amps, it can give lower offset voltage and drift at a lower cost.

The LM107 is guaranteed over a  $-55^{\circ}\text{C}$  to  $+125^{\circ}\text{C}$  temperature range, the LM207 from  $-25^{\circ}\text{C}$  to  $+85^{\circ}\text{C}$  and the LM307 from  $0^{\circ}\text{C}$  to  $+70^{\circ}\text{C}$ .

### Features

- Offset voltage 3 mV maximum over temperature
- Input current 100 nA maximum over temperature
- Offset current 20 nA maximum over temperature
- Guaranteed drift characteristics

### Connection Diagrams

Metal Can Package

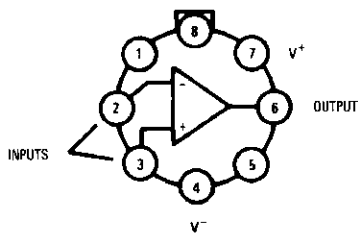

TL/H/7757-2

Note: Pin 4 connected to case.

Top View

Order Number LM107H/883\*  
See NS Package Number H08C

Dual-in-Line Package

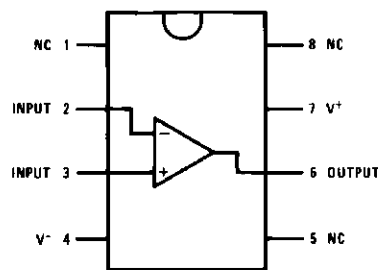

TL/H/7757-3

Top View

Order Number LM107J/883\* or LM207J  
See NS Package Number J08A

Order Number LM307N  
See NS Package Number N08A

Dual-in-Line Package

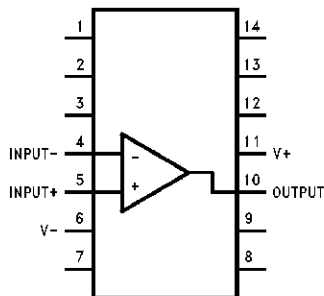

TL/H/7757-13

Order Number LM107J-14/883\*  
See NS Package Number J14A

\* Available per SMD # 5962-8958901.

## Absolute Maximum Ratings

If Military/Aerospace specified devices are required, please contact the National Semiconductor Sales Office/Distributors for availability and specifications.  
(Note 4)

	LM107/LM207	LM307		T <sub>MIN</sub>	T <sub>MAX</sub>
Supply Voltage	± 22V	± 18V			
Power Dissipation (Note 1)	500 mW	500 mW			
Differential Input Voltage	± 30V	± 30V	LM107	-55°C	+ 125°C
Input Voltage (Note 2)	± 15V	± 15V	LM207	-25°C	+ 85°C
Output Short Circuit Duration	Continuous	Continuous	LM307	0°C	+ 70°C
Operating Temperature Range (T <sub>A</sub> )			ESD rating to be determined.		
(LM107)	-55°C to + 125°C	0°C to + 70°C			
(LM207)	-25°C to + 85°C				
Storage Temperature Range	-65°C to + 150°C	-65°C to + 150°C			
Lead Temperature (Soldering, 10 sec)	260°C	260°C			

## Electrical Characteristics (Note 3)

Parameter	Conditions	LM107/LM207			LM307			Units
		Min	Typ	Max	Min	Typ	Max	
Input Offset Voltage	T <sub>A</sub> = 25°C, R <sub>S</sub> ≤ 50 kΩ		0.7	2.0		2.0	7.5	mV
Input Offset Current	T <sub>A</sub> = 25°C		1.5	10		3.0	50	nA
Input Bias Current	T <sub>A</sub> = 25°C		30	75		70	250	nA
Input Resistance	T <sub>A</sub> = 25°C	1.5	4.0		0.5	2.0		MΩ
Supply Current	T <sub>A</sub> = 25°C V <sub>S</sub> = ± 20V V <sub>S</sub> = ± 15V		1.8	3.0		1.8	3.0	mA mA
Large Signal Voltage Gain	T <sub>A</sub> = 25°C, V <sub>S</sub> = ± 15V V <sub>OUT</sub> = ± 10V, R <sub>L</sub> ≥ 2 kΩ	50	160		25	160		V/mV
Input Offset Voltage	R <sub>S</sub> ≤ 50 kΩ			3.0			10	mV
Average Temperature Coefficient of Input Offset Voltage			3.0	15		6.0	30	μV/°C
Input Offset Current				20			70	nA
Average Temperature Coefficient of Input Offset Current	25°C ≤ T <sub>A</sub> ≤ T <sub>MAX</sub> T <sub>MIN</sub> ≤ T <sub>A</sub> ≤ 25°C		0.01 0.02	0.1 0.2		0.01 0.02	0.3 0.6	nA/°C nA/°C
Input Bias Current				100			300	nA
Supply Current	T <sub>A</sub> = + 125°C, V <sub>S</sub> = ± 20V		1.2	2.5				mA

## Electrical Characteristics (Note 3) (Continued)

Parameter	Conditions	LM107/LM207			LM307			Units
		Min	Typ	Max	Min	Typ	Max	
Large Signal Voltage Gain	$V_S = \pm 15V$ , $V_{OUT} = \pm 10V$ $R_L \geq 2 k\Omega$	25			15			V/mV
Output Voltage Swing	$V_S = \pm 15V$	$\pm 12$	$\pm 14$		$\pm 12$	$\pm 14$		V
	$R_L = 10 k\Omega$ $R_L = 2 k\Omega$	$\pm 10$	$\pm 13$		$\pm 10$	$\pm 13$		V
Input Voltage Range	$V_S = \pm 20V$	$\pm 15$			$\pm 12$			V
	$V_S = \pm 15V$		+ 15 - 13			+ 15 - 13		V
Common Mode Rejection Ratio	$R_S \leq 50 k\Omega$	80	96		70	90		dB
Supply Voltage Rejection Ratio	$R_S \leq 50 k\Omega$	80	96		70	96		dB

**Note 1:** The maximum junction temperature of the LM107 is 150°C, and the LM207/LM307 is 100°C. For operating at elevated temperatures, devices in the H08 package must be derated based on a thermal resistance of 165°C/W, junction to ambient, or 30°C/W, junction to case. The thermal resistance of the dual-in-line package is 100°C/W, junction to ambient.

**Note 2:** For supply voltages less than  $\pm 15V$ , the absolute maximum input voltage is equal to the supply voltage.

**Note 3:** These specifications apply for  $\pm 5V \leq V_S \leq +20V$  and  $-55^\circ C \leq T_A \leq +125^\circ C$  for the LM107 or  $-25^\circ C \leq T_A \leq +85^\circ C$  for the LM207, and  $0^\circ C \leq T_A \leq +70^\circ C$  and  $\pm 5V \leq V_S \leq \pm 15V$  for the LM307 unless otherwise specified.

**Note 4:** Refer to RETS107X for LM107H and LM107J military specifications.

## Schematic Diagram \*

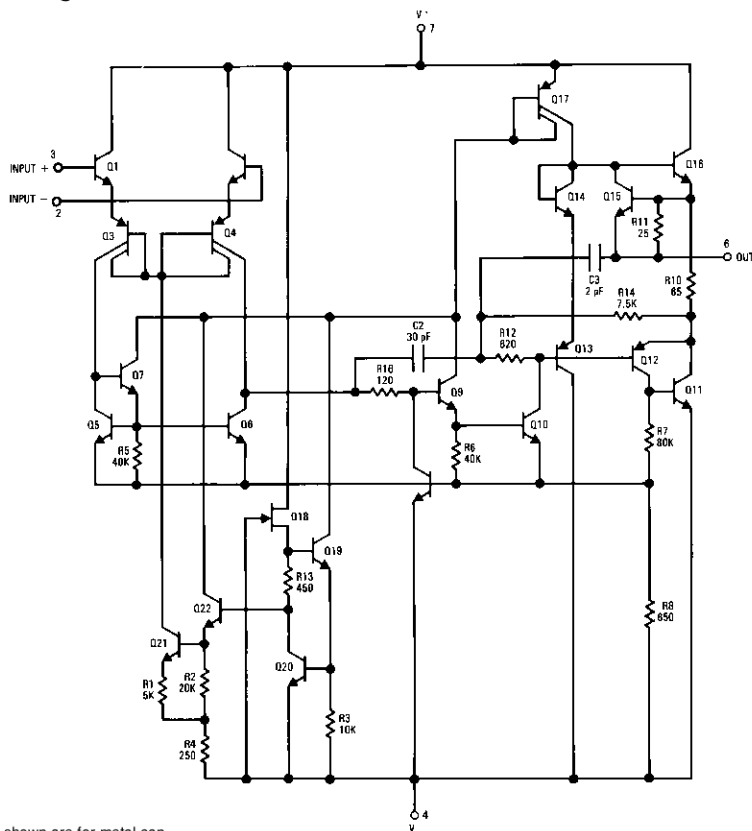

\*Pin connections shown are for metal can.

TL/H/7757-1

## Guaranteed Performance Characteristics LM107/LM207

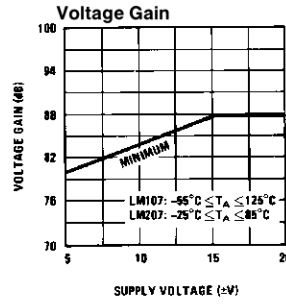
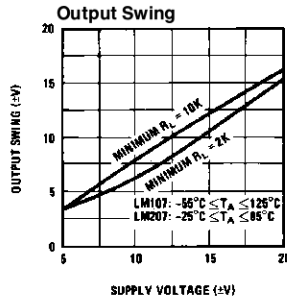
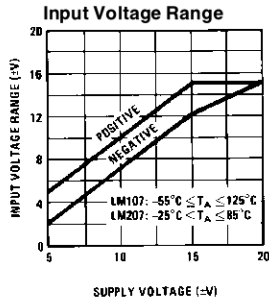

TL/H/7757-4

## Guaranteed Performance Characteristics LM307

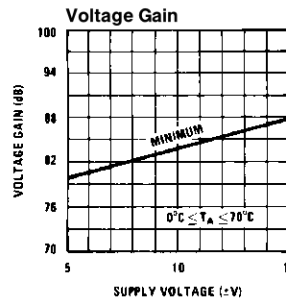
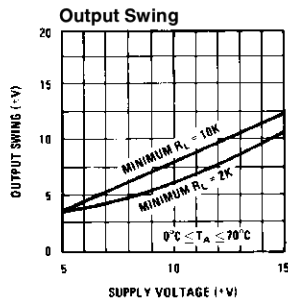
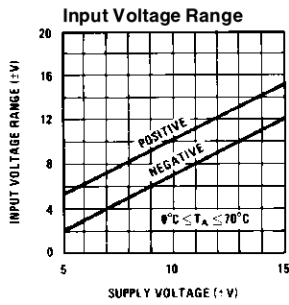

TL/H/7757-5

## Typical Performance Characteristics

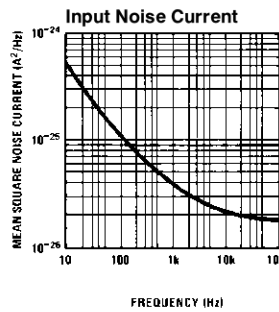
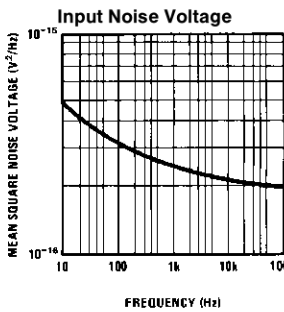
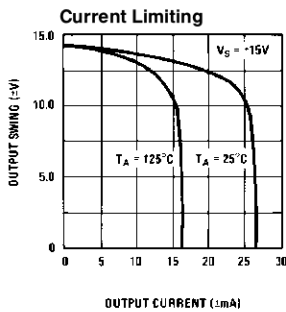
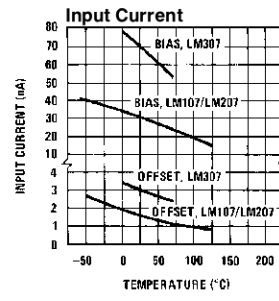
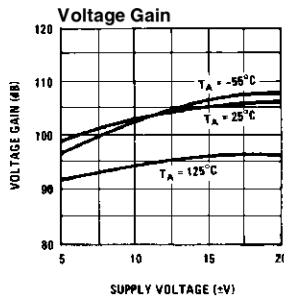
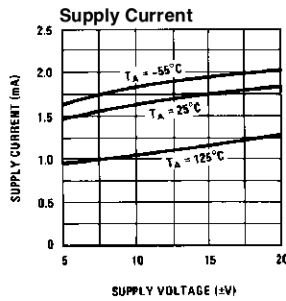

TL/H/7757-6

## Typical Performance Characteristics (Continued)

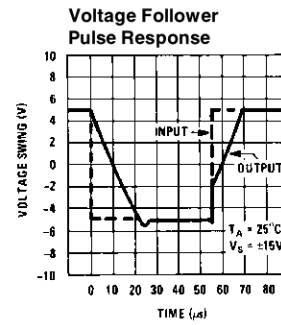
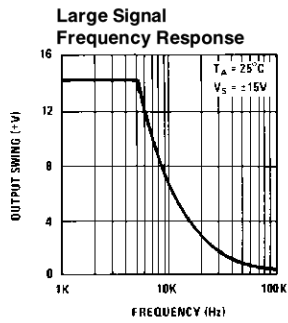
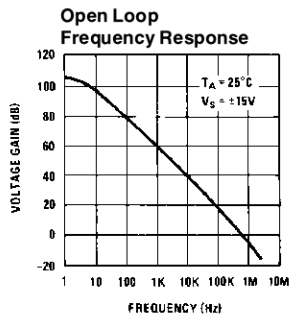

TL/H/7757-7

## Typical Applications\*\*

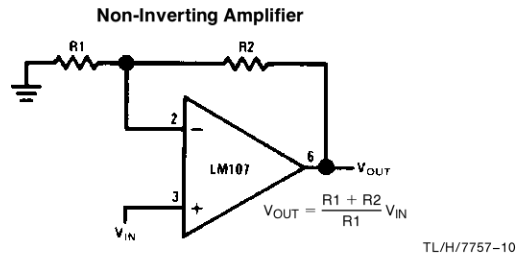
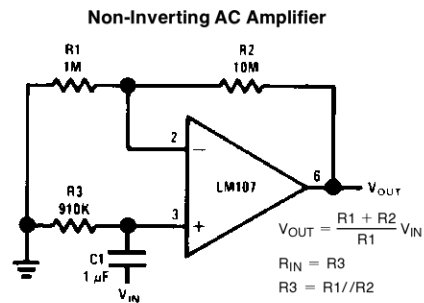
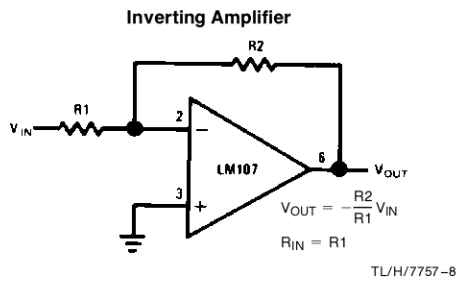

\*\*Pin connections shown are for metal can.

Typical Applications\*\* (Continued)

Turntable Notch Filter

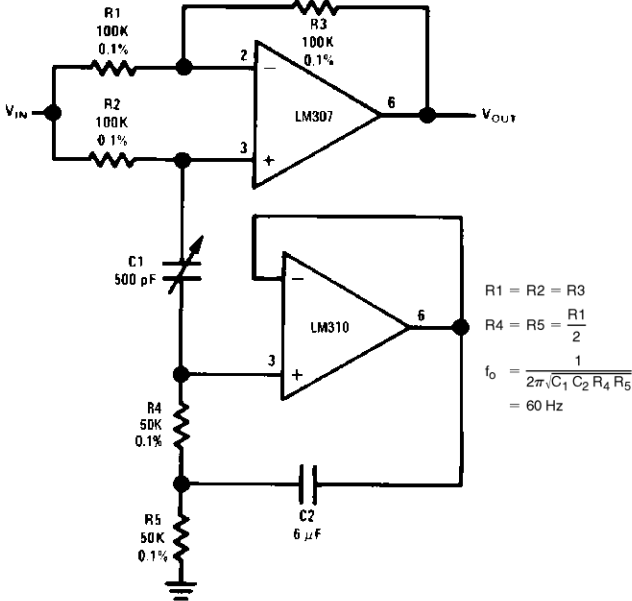

TL/H/7757-11

Differential Input Instrumentation Amplifier

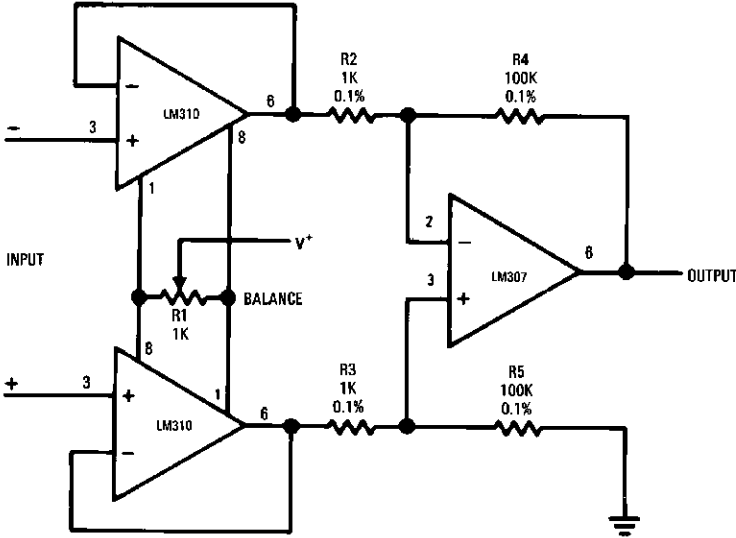

TL/H/7757-12

\*\*Pin connections shown are for metal can.



**Physical Dimensions** inches (millimeters)

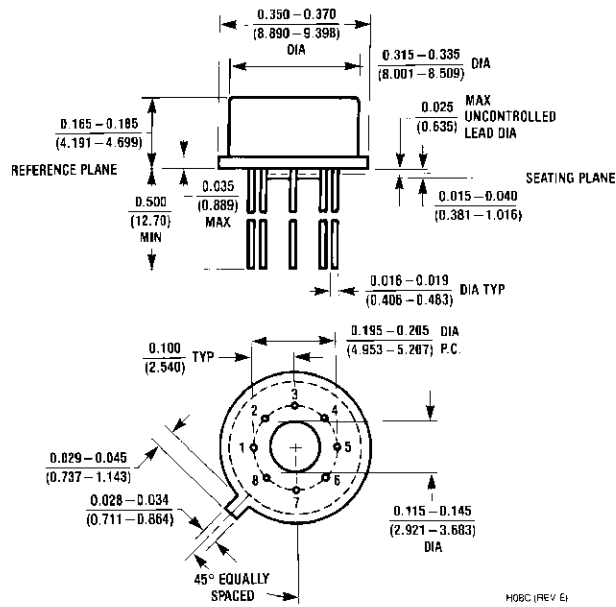

H08C (REV. E)

**Metal Can Package (H)**  
**Order Number LM107H/883**  
**NS Package Number H08C**



**Physical Dimensions** inches (millimeters) (Continued)

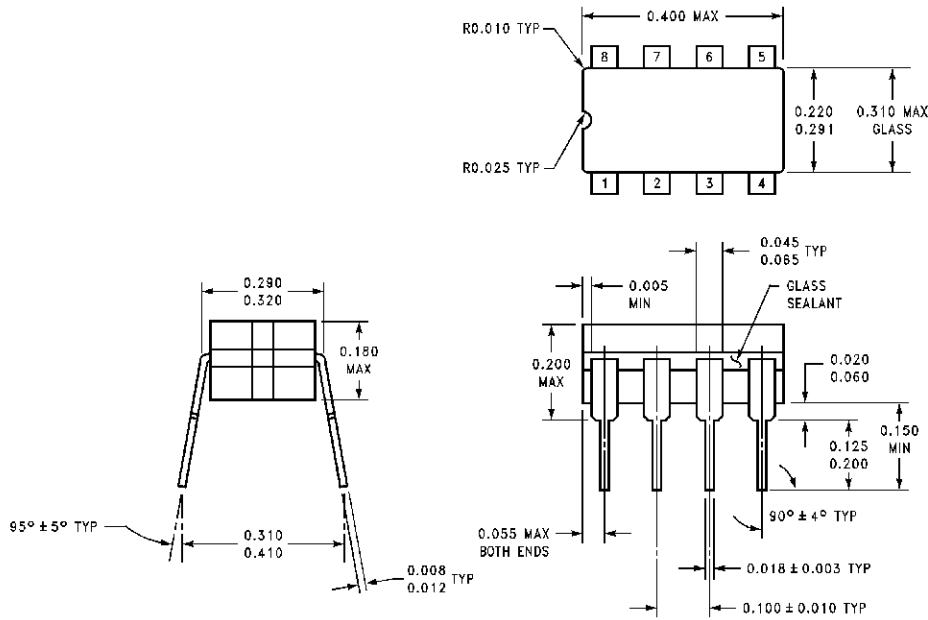

**Ceramic Dual-In-Line Package (J)**  
**Order Number LM107J/883 or LM207J**  
**NS Package Number J08A**

J08A (REV K)

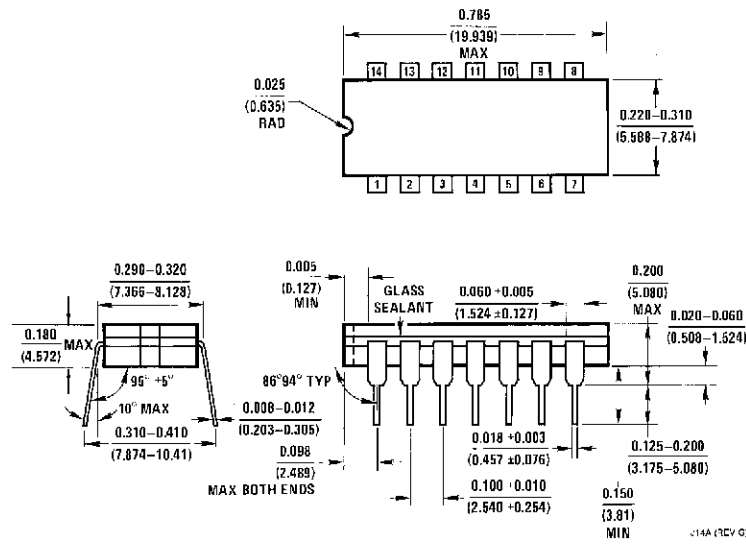

**Ceramic Dual-In-Line Package (J)**  
**Order Number LM107J-14/883**  
**NS Package Number J14A**

J14A (REV G)

**Physical Dimensions** inches (millimeters) (Continued)

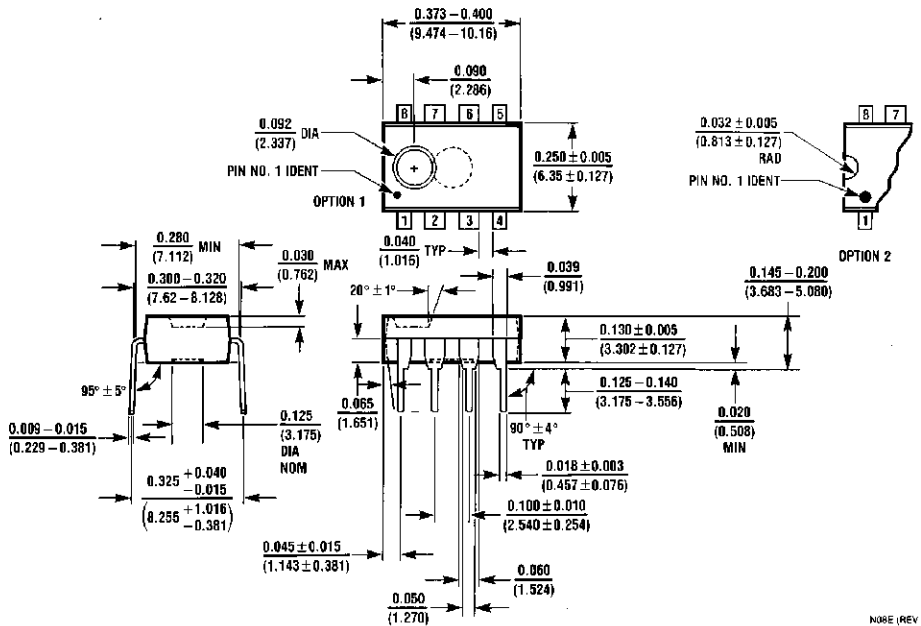

**Molded Dual-In-Line Package (N)**  
**Order Number LM307N**  
**NS Package Number N08E**

N08E (REV F)

**LIFE SUPPORT POLICY**

NATIONAL'S PRODUCTS ARE NOT AUTHORIZED FOR USE AS CRITICAL COMPONENTS IN LIFE SUPPORT DEVICES OR SYSTEMS WITHOUT THE EXPRESS WRITTEN APPROVAL OF THE PRESIDENT OF NATIONAL SEMICONDUCTOR CORPORATION. As used herein:

1. Life support devices or systems are devices or systems which, (a) are intended for surgical implant into the body, or (b) support or sustain life, and whose failure to perform, when properly used in accordance with instructions for use provided in the labeling, can be reasonably expected to result in a significant injury to the user.
2. A critical component is any component of a life support device or system whose failure to perform can be reasonably expected to cause the failure of the life support device or system, or to affect its safety or effectiveness.



**National Semiconductor Corporation**  
 1111 West Bardin Road  
 Arlington, TX 76017  
 Tel: 1(800) 272-9959  
 Fax: 1(800) 737-7018

**National Semiconductor Europe**  
 Fax: (+49) 0-180-530 85 86  
 Email: cnjwge@tevm2.nsc.com  
 Deutsch Tel: (+49) 0-180-530 85 85  
 English Tel: (+49) 0-180-532 78 32  
 Français Tel: (+49) 0-180-532 93 58  
 Italiano Tel: (+49) 0-180-534 16 80

**National Semiconductor Hong Kong Ltd.**  
 13th Floor, Straight Block,  
 Ocean Centre, 5 Canton Rd.  
 Tsimshatsui, Kowloon  
 Hong Kong  
 Tel: (852) 2737-1600  
 Fax: (852) 2736-9960

**National Semiconductor Japan Ltd.**  
 Tel: 81-043-299-2309  
 Fax: 81-043-299-2408

National does not assume any responsibility for use of any circuitry described, no circuit patent licenses are implied and National reserves the right at any time without notice to change said circuitry and specifications.

This datasheet has been download from:

[www.datasheetcatalog.com](http://www.datasheetcatalog.com)

Datasheets for electronics components.

# National Semiconductor was acquired by Texas Instruments.

[http://www.ti.com/corp/docs/investor\\_relations/pr\\_09\\_23\\_2011\\_national\\_semiconductor.html](http://www.ti.com/corp/docs/investor_relations/pr_09_23_2011_national_semiconductor.html)

This file is the datasheet for the following electronic components:

LM207 - <http://www.ti.com/product/lm207?HQS=TI-null-null-dscatalog-df-pf-null-wwe>

LM107 - <http://www.ti.com/product/lm107?HQS=TI-null-null-dscatalog-df-pf-null-wwe>

LM307 - <http://www.ti.com/product/lm307?HQS=TI-null-null-dscatalog-df-pf-null-wwe>