

“ZNR” Transient/Surge Absorbers

Type: **D**

Series: **E**

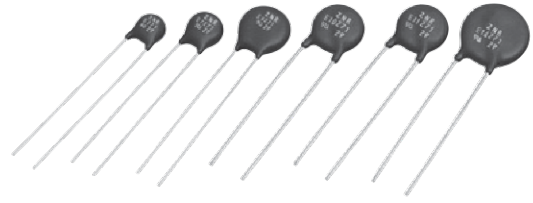

“ZNR” Transient/Surge Absorber, Series E, Type D features large surge current and energy handling capability for absorbing transient overvoltage in a compact size.

Features

- Large withstanding surge current capability in compact sizes
- Large “Energy Handling Capability” absorbing transient overvoltages in compact sizes
- Wide range of varistor voltages
- RoHS compliant

Recommended Applications

- Transistor, diode, IC, thyristor or triac semiconductor protection
- Surge protection in consumer electronic equipment
- Surge protection in communication, measuring or controller electronics
- Surge protection in electronic home appliances, gas or petroleum appliances

Applicable Standards

- UL1449 (VZCA2/UL, VZCA8/C-UL)
 - VDE IEC61051-1, -2, -2-2, IEC60950-1 Annex.Q
 - CQC(GB/T10193, GB/T10194, GB4943.1, GB8898)
- Refer to pages 32 to 33, and 49 for the details

As for Handling Precautions and Minimum Quantity / Packing Unit

Please see Related Information

Explanation of Part Numbers

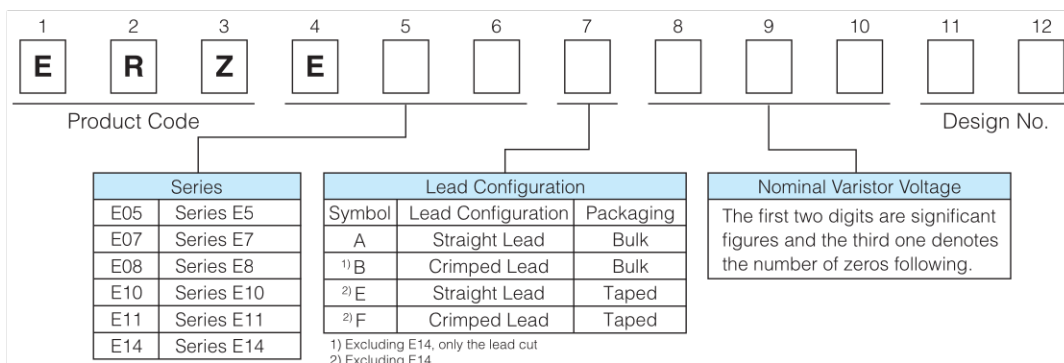

Reference Guide to Standard Products

Part No.	Applicable Standards		Varistor Voltage at 1 mA (V)	Maximum Allowable Voltage		Clamping Voltage at 8/20 μ s		Maximum Peak Current at 8/20 μ s(A)		Recommended Applications	
	Type Name	Approvals		ACrms (V)	DC (V)	max.(V)	I _p (A)	1 time	2 times		
ERZE05A201	E201	○☆◇	200 (185 to 225)	130	170	340	10	1200	600	AC 100 V Line-Line Applications	
ERZE07A201	E7201	○☆◇				340	25	2500	1250		
ERZE08A201	E8201	○☆◇				340	25	3500	2500		
ERZE10A201	E10201	○☆◇				340	50	4500	3000		
ERZE11A201	E11201	○☆★◇◆				340	50	6000	5000		
ERZE14A201	E14201	○☆★◇◆				340	100	10000	7000		
ERZE05A221	E221	○☆◇	220 (198 to 242)	140	180	360	10	1200	600		
ERZE07A221	E7221	○☆◇				360	25	2500	1250		
ERZE08A221	E8221	○☆◇				360	25	3500	2500		
ERZE10A221	E10221	○☆◇				360	50	4500	3500		
ERZE11A221	E11221	○☆★◇◆				360	50	6000	5000		
ERZE14A221	E14221	○☆★◇◆				360	100	10000	7000		
ERZE05A241	E241	○☆◇	240 (216 to 264)	150	200	395	10	1200	600	AC 100 V to 120 V, Line-Line Applications	
ERZE07A241	E7241	○☆◇				395	25	2500	1250		
ERZE08A241	E8241	○☆◇				395	25	3500	2500		
ERZE10A241	E10241	○☆◇				395	50	4500	3000		
ERZE11A241	E11241	○☆★◇◆				395	50	6000	5000		
ERZE14A241	E14241	○☆★◇◆				395	100	10000	7000		
ERZE05A271	E271	○☆◇	270 (247 to 303)	175	225	455	10	1200	600		
ERZE07A271	E7271	○☆◇				455	25	2500	1250		
ERZE08A271	E8271	○☆◇				455	25	3500	2500		
ERZE10A271	E10271	○☆◇				455	50	4500	3000		
ERZE11A271	E11271	○☆★◇◆				455	50	6000	5000		
ERZE14A271	E14271	○☆★◇◆				455	100	10000	7000		
ERZE05A331	E331	○☆◇	330 (297 to 363)	210	270	545	10	1200	600	AC 100 V to 120 V, Line-Line Applications	
ERZE07A331	E7331	○☆◇				545	25	2500	1250		
ERZE08A331	E8331	○☆◇				545	25	3500	2500		
ERZE10A331	E10331	○☆◇				545	50	4500	3000		
ERZE11A331	E11331	○☆★◇◆				545	50	6000	4500		
ERZE14A331	E14331	○☆★◇◆				545	100	10000	6500		
ERZE05A361	E361	○☆◇	360 (324 to 396)	230	300	595	10	1200	600		AC 100 V to 120 V, Line-Line Applications Telephone Line Applications, (For DC 250 V Insulation Resistance Test)
ERZE07A361	E7361	○☆◇				595	25	2500	1250		
ERZE08A361	E8361	○☆◇				595	25	3500	2500		
ERZE10A361	E10361	○☆◇				595	50	4500	3000		
ERZE11A361	E11361	○☆★◇◆				595	50	6000	4500		
ERZE14A361	E14361	○☆★◇◆				595	100	10000	6500		
ERZE05A391	E391	○☆◇	390 (351 to 429)	250	320	650	10	1200	600		
ERZE07A391	E7391	○☆◇				650	25	2500	1250		
ERZE08A391	E8391	○☆◇				650	25	3500	2500		
ERZE10A391	E10391	○☆◇				650	50	4500	3000		
ERZE11A391	E11391	○☆★◇◆				650	50	6000	4500		
ERZE14A391	E14391	○☆★◇◆				650	100	10000	6500		
ERZE05A431	E431	○☆◇	430 (387 to 473)	275	350	710	10	1200	600	AC 100 V to 220 V, Line-Line and Line-Ground Applications	
ERZE07A431	E7431	○☆◇				710	25	2500	1250		
ERZE08A431	E8431	○☆◇				710	25	3500	2500		
ERZE10A431	E10431	○☆◇				710	50	4500	3000		
ERZE11A431	E11431	○☆★◇◆				710	50	6000	4500		
ERZE14A431	E14431	○☆★◇◆				710	100	10000	6500		

○ : UL1449 (VZCA2/UL, VZCA8/C-UL), ☆ : VDE (IEC61051-1, -2, -2-2), ★ : VDE (IEC60950-1 Annex.Q),
◇ : CQC (GB/T10193, GB/T10194), ◆ : CQC (GB4943.1, GB8898)

※ Approval number (File No.) of safety regulations are subject to revision without notice. Ask factory for a copy of the latest file No.

Reference Guide to Standard Products

Part No.	Applicable Standards		Varistor Voltage at 1 mA (V)	Maximum Allowable Voltage		Clamping Voltage at 8/20μs		Maximum Peak Current at 8/20μs(A)		Recommended Applications	
	Type Name	Approvals		ACrms (V)	DC (V)	max.(V)	Ip (A)	1 time	2 times		
ERZE05A471	E471	○☆◇	470 (423 to 517)	300	385	775	10	1200	600	AC 100 V to 220 V, Line-Line and Line-Ground Applications	
ERZE07A471	E7471	○☆◇				775	25	2500	1250		
ERZE08A471	E8471	○☆★◇◆				775	25	3500	2500		
ERZE10A471	E10471	○☆★◇◆				775	50	4500	3000		
ERZE11A471	E11471	○☆★◇◆				775	50	6000	4500		
ERZE14A471	E14471	○☆★◇◆				775	100	10000	6500		
ERZE07A511	E7511	○☆◇	510 (459 to 561)	320	410	845	25	2500	1250	AC 100 V to 240 V, Line-Line and Line-Ground Applications	
ERZE08A511	E8511	○☆★◇◆				845	25	3500	2500		
ERZE10A511	E10511	○☆★◇◆				845	50	4500	3000		
ERZE11A511	E11511	○☆★◇◆				845	50	6000	4500		
ERZE14A511	E14511	○☆★◇◆				845	100	10000	6500		
ERZE07A561	E7561	○☆◇	560 (504 to 616)	350	450	930	25	2500	1250		
ERZE08A561	E8561	○☆★◇◆				930	25	3500	2500		
ERZE10A561	E10561	○☆★◇◆				930	50	4500	3000		
ERZE11A561	E11561	○☆★◇◆				930	50	6000	4500		
ERZE14A561	E14561	○☆★◇◆				930	100	10000	6500		
ERZE07A621	E7621	○☆◇	620 (558 to 682)	385	505	1025	25	2500	1250	AC 100 V to 240 V, Line-Line and Line-Ground Applications	
ERZE08A621	E8621	○☆★◇◆				1025	25	3500	2500		
ERZE10A621	E10621	○☆★◇◆				1025	50	4500	3000		
ERZE11A621	E11621	○☆★◇◆				1025	50	5000	4500		
ERZE14A621	E14621	○☆★◇◆				1025	100	7500	6500		
ERZE08A681	E8681	○☆★◇◆	680 (612 to 748)	420	560	1120	25	3500	2500		
ERZE10A681	E10681	○☆★◇◆				1120	50	4500	3000		
ERZE11A681	E11681	○☆★◇◆				1120	50	5000	4500		
ERZE14A681	E14681	○☆★◇◆				1120	100	7500	6500		
ERZE08A751	E8751	○☆★◇◆	750 (675 to 825)	460	615	1240	25	3500	2500		AC 380 V, Line-Line and Line-Ground Applications (For DC 500 V Insulating Test)
ERZE10A751	E10751	○☆★◇◆				1240	50	4500	3000		
ERZE11A751	E11751	○☆★◇◆				1240	50	5000	4500		
ERZE14A751	E14751	○☆★◇◆				1240	100	7500	6500		
ERZE10A821	E10821	○☆★◇◆	820 (738 to 902)	510	670	1355	50	4500	3000		
ERZE11A821	E11821	○☆★◇◆				1355	50	5000	4500		
ERZE14A821	E14821	○☆★◇◆				1355	100	7500	6500		
ERZE10A911	E10911	○☆★◇◆	910 (819 to 1001)	550	745	1500	50	4500	3000	AC 415 V, Line-Line and Line-Ground Applications (For DC 500 V Insulating Test)	
ERZE11A911	E11911	○☆★◇◆				1500	50	5000	4500		
ERZE14A911	E14911	○☆★◇◆				1500	100	7500	6500		
ERZE10A102	E10102	○☆★◇◆	1000 (900 to 1100)	625	825	1650	50	4500	3000	AC 480 V, Line-Line and Line-Ground Applications (For DC 500 V Insulating Test)	
ERZE11A102	E11102	○☆★◇◆				1650	50	5000	4500		
ERZE14A102	E14102	○☆★◇◆				1650	100	7500	6500		
ERZE10A112	E10112	○☆★◇◆	1100 (990 to 1210)	680	895	1815	50	4500	3000		
ERZE11A112	E11112	○☆★◇◆				1815	50	5000	4500		
ERZE14A112	E14112	○☆★◇◆				1815	100	7500	6500		

○ : UL1449 (VZCA2/UL, VZCA8/C-UL), ☆ : VDE (IEC61051-1, -2, -2-2), ★ : VDE (IEC60950-1 Annex.Q),

◇ : CQC (GB/T10193, GB/T10194), ◆ : CQC (GB4943.1, GB8998)

※ Approval number (File No.) of safety regulations are subject to revision without notice. Ask factory for a copy of the latest file No.

Series E5

Ratings and Characteristics

- Operating Temperature Range : -40 to 85 °C
- Storage Temperature Range : -40 to 125 °C

Part No.	Varistor Voltage $V_{1\text{mA}}$ (V)	Maximum Allowable Voltage		Clamping Voltage (max.) *I _p (V)	Rated Power (W)	Maximum Energy		Maximum Peak Current (8/20 μs)		Capacitance (max.) at 1 kHz (pF)
		ACrms (V)	DC (V)			(10/1000 μs)	(2 ms)	1 time	2 times	
						(J)	(J)	(A)	(A)	
ERZE05A201	200(185 to 225)	130	170	340	0.25	13	9.5	1200	600	200
ERZE05A221	220(198 to 242)	140	180	360	0.25	14	10	1200	600	190
ERZE05A241	240(216 to 264)	150	200	395	0.25	15	11	1200	600	170
ERZE05A271	270(247 to 303)	175	225	455	0.25	18	13	1200	600	150
ERZE05A331	330(297 to 363)	210	270	545	0.25	21	15	1200	600	130
ERZE05A361	360(324 to 396)	230	300	595	0.25	23	17	1200	600	130
ERZE05A391	390(351 to 429)	250	320	650	0.25	26	19	1200	600	130
ERZE05A431	430(387 to 473)	275	350	710	0.25	29	21	1200	600	120
ERZE05A471	470(423 to 517)	300	385	775	0.25	32	23	1200	600	100

*I_p Measuring current of clamping voltage : 10 A

Dimensions in mm (not to scale)

Part No.	D max.	T max.	F±1.0	A max.	L±1.0
ERZE05A201	7.0	4.8	5.0	10.0	2.1
ERZE05A221	7.0	4.9	5.0	10.0	2.3
ERZE05A241	7.0	5.0	5.0	10.0	2.4
ERZE05A271	7.0	5.2	5.0	10.0	2.5
ERZE05A331	7.0	5.5	5.0	10.0	2.9
ERZE05A361	7.0	5.8	5.0	10.0	3.1
ERZE05A391	7.0	5.9	5.0	10.0	3.2
ERZE05A431	7.0	6.1	5.0	10.0	3.3
ERZE05A471	7.0	6.3	5.0	10.0	3.5

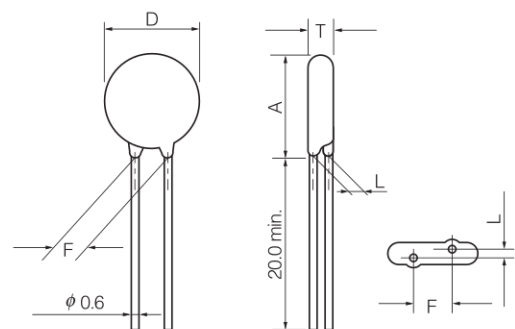

Typical Characteristics

Voltage vs. Current

ERZE05A201 to ERZE05A471

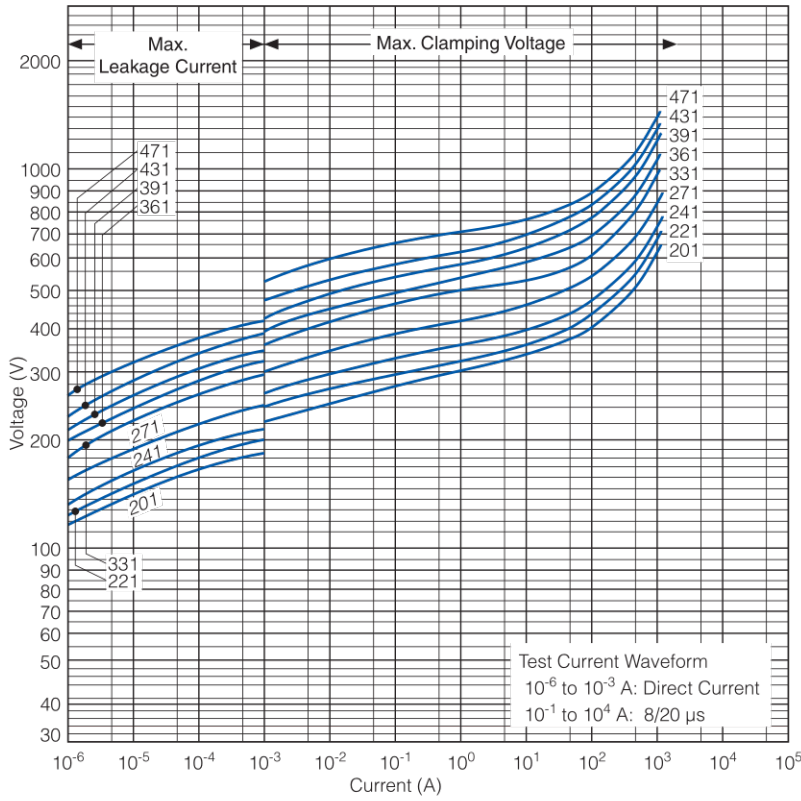

Impulse Derating (Relation between impulse width and impulse current multiple)

ERZE05A201 to ERZE05A471

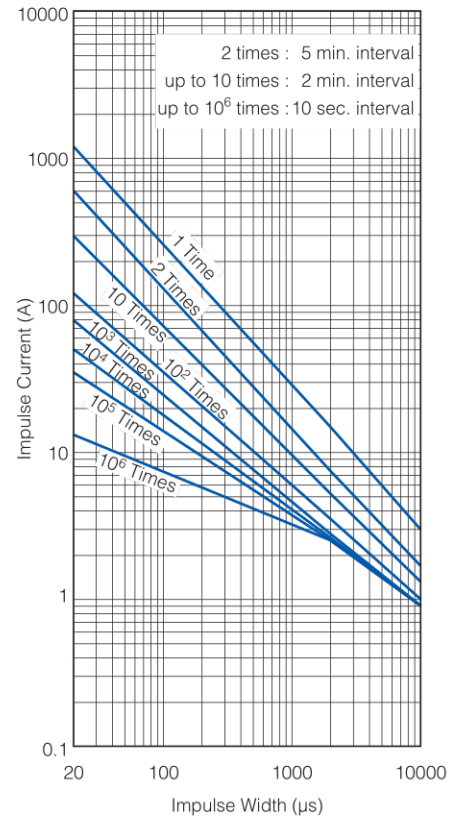

Series E7

Ratings and Characteristics

- Operating Temperature Range : -40 to 85 °C
- Storage Temperature Range : -40 to 125 °C

Part No.	Varistor Voltage $V_{1\text{mA}}$ (V)	Maximum Allowable Voltage		Clamping Voltage (max.) *I _p (V)	Rated Power (W)	Maximum Energy		Maximum Peak Current (8/20 μs)		Capacitance (max.) at 1 kHz (pF)
		ACrms (V)	DC (V)			(10/1000 μs)	(2 ms)	1 time	2 times	
						(J)	(J)	(A)	(A)	
ERZE07A201	200(185 to 225)	130	170	340	0.3	26	19	2500	1250	360
ERZE07A221	220(198 to 242)	140	180	360	0.3	30	22	2500	1250	350
ERZE07A241	240(216 to 264)	150	200	395	0.3	33	24	2500	1250	340
ERZE07A271	270(247 to 303)	175	225	455	0.3	39	28	2500	1250	310
ERZE07A331	330(297 to 363)	210	270	545	0.3	44	32	2500	1250	280
ERZE07A361	360(324 to 396)	230	300	595	0.3	50	36	2500	1250	260
ERZE07A391	390(351 to 429)	250	320	650	0.3	53	38	2500	1250	240
ERZE07A431	430(387 to 473)	275	350	710	0.3	60	43	2500	1250	210
ERZE07A471	470(423 to 517)	300	385	775	0.3	65	47	2500	1250	170
ERZE07A511	510(459 to 561)	320	410	845	0.3	70	50	2500	1250	140
ERZE07A561	560(504 to 616)	350	450	930	0.3	75	55	2500	1250	140
ERZE07A621	620(558 to 682)	385	505	1025	0.3	80	60	2500	1250	135

*I_p Measuring current of clamping voltage : 25 A

Dimensions in mm (not to scale)

Part No.	D max.	T max.	F±1.0	A max.	L±1.0
ERZE07A201	9.0	5.3	7.5	12.5	2.1
ERZE07A221	9.0	5.4	7.5	12.5	2.3
ERZE07A241	9.0	5.5	7.5	12.5	2.4
ERZE07A271	9.0	5.7	7.5	12.5	2.5
ERZE07A331	9.0	6.0	7.5	12.5	2.8
ERZE07A361	9.0	6.2	7.5	12.5	2.9
ERZE07A391	9.0	6.3	7.5	12.5	3.0
ERZE07A431	9.0	6.5	7.5	12.5	3.1
ERZE07A471	9.0	6.8	7.5	12.5	3.3
ERZE07A511	9.0	7.0	7.5	12.5	3.5
ERZE07A561	9.0	7.4	7.5	13.5	3.8
ERZE07A621	10.0	7.8	7.5	13.5	4.0

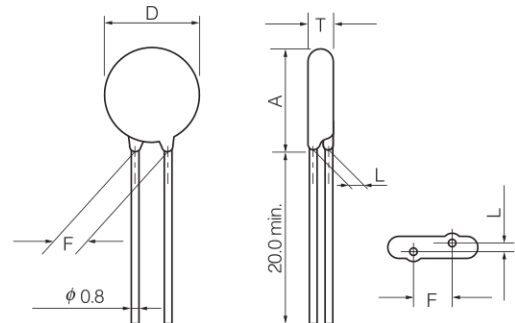

Typical Characteristics

Voltage vs. Current

ERZE07A201 to ERZE07A621

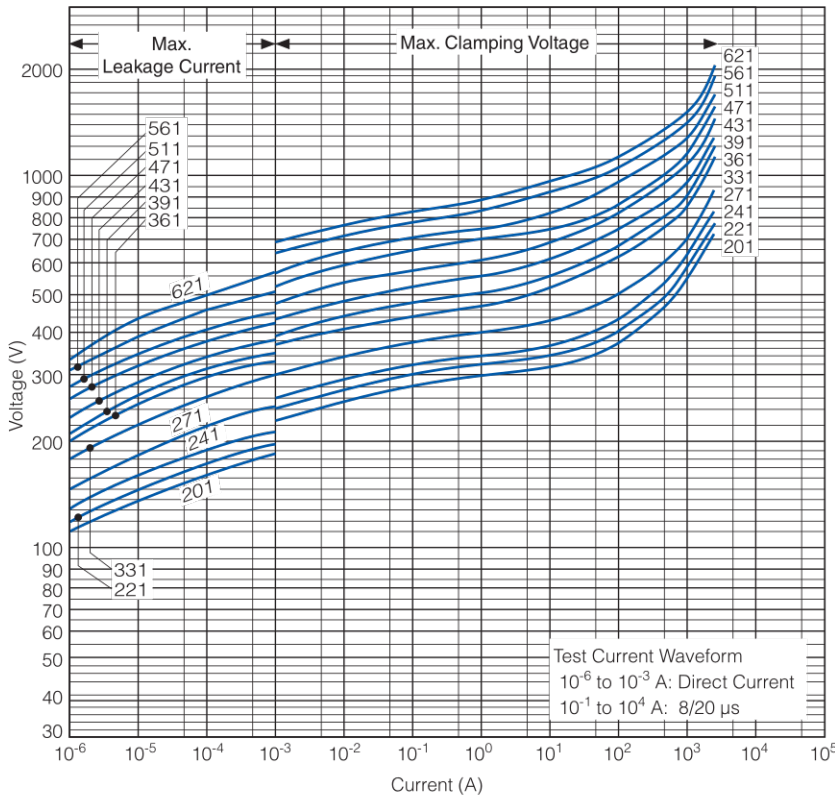

Impulse Derating (Relation between impulse width and impulse current multiple)

ERZE07A201 to ERZE07A621

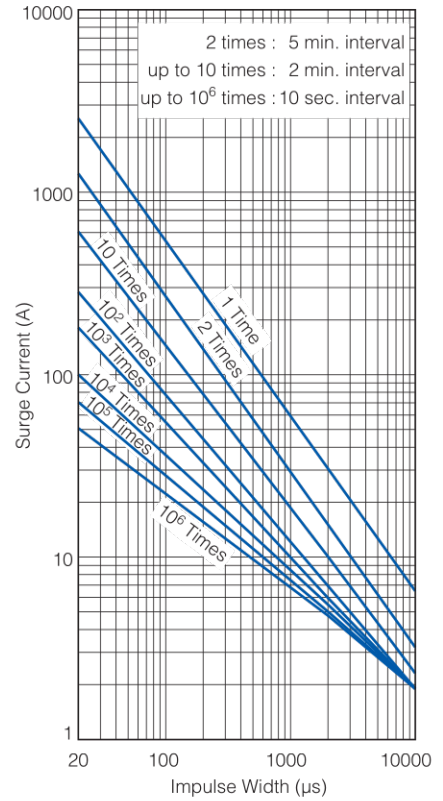

Series E8

Ratings and Characteristics

- Operating Temperature Range : -40 to 85 °C
- Storage Temperature Range : -40 to 125 °C

Part No.	Varistor Voltage V_{1mA} (V)	Maximum Allowable Voltage		Clamping Voltage (max.) *I _p (V)	Rated Power (W)	Maximum Energy		Maximum Peak Current (8/20 μs)		Capacitance (max.) at 1 kHz (pF)
		ACrms (V)	DC (V)			(10/1000 μs) (J)	(2 ms) (J)	1 time (A)	2 times (A)	
ERZE08A201	200(185 to 225)	130	170	340	0.4	35	25	3500	2500	390
ERZE08A221	220(198 to 242)	140	180	360	0.4	39	27.5	3500	2500	380
ERZE08A241	240(216 to 264)	150	200	395	0.4	42	30	3500	2500	360
ERZE08A271	270(247 to 303)	175	225	455	0.4	49	35	3500	2500	330
ERZE08A331	330(297 to 363)	210	270	545	0.4	58	42	3500	2500	300
ERZE08A361	360(324 to 396)	230	300	595	0.4	65	45	3500	2500	280
ERZE08A391	390(351 to 429)	250	320	650	0.4	70	50	3500	2500	260
ERZE08A431	430(387 to 473)	275	350	710	0.4	80	55	3500	2500	230
ERZE08A471	470(423 to 517)	300	385	775	0.4	85	60	3500	2500	180
ERZE08A511	510(459 to 561)	320	410	845	0.4	92	67	3500	2500	150
ERZE08A561	560(504 to 616)	350	450	930	0.4	92	67	3500	2500	150
ERZE08A621	620(558 to 682)	385	505	1025	0.4	92	67	3500	2500	140
ERZE08A681	680(612 to 748)	420	560	1120	0.4	92	67	3500	2500	130
ERZE08A751	750(675 to 825)	460	615	1240	0.4	100	70	3500	2500	130

*I_p Measuring current of clamping voltage : 25 A

Dimensions in mm (not to scale)

Part No.	D max.	T max.	F±1.0	A max.	L±1.0
ERZE08A201	10.5	5.1	7.5	13.5	1.9
ERZE08A221	10.5	5.2	7.5	13.5	2.0
ERZE08A241	10.5	5.3	7.5	13.5	2.1
ERZE08A271	10.5	5.5	7.5	13.5	2.3
ERZE08A331	10.5	5.9	7.5	13.5	2.6
ERZE08A361	10.5	6.1	7.5	13.5	2.8
ERZE08A391	10.5	6.3	7.5	13.5	2.9
ERZE08A431	10.5	6.5	7.5	13.5	3.1
ERZE08A471	10.5	7.3	7.5	13.5	3.6
ERZE08A511	10.5	7.8	7.5	13.5	4.0
ERZE08A561	10.5	8.1	7.5	13.5	4.3
ERZE08A621	11.5	8.7	7.5	14.5	4.7
ERZE08A681	11.5	9.0	7.5	14.5	5.0
ERZE08A751	11.5	9.7	7.5	14.5	5.6

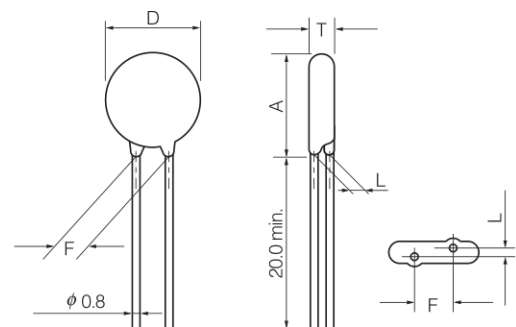

Typical Characteristics

Voltage vs. Current

ERZE08A201 to ERZE08A511

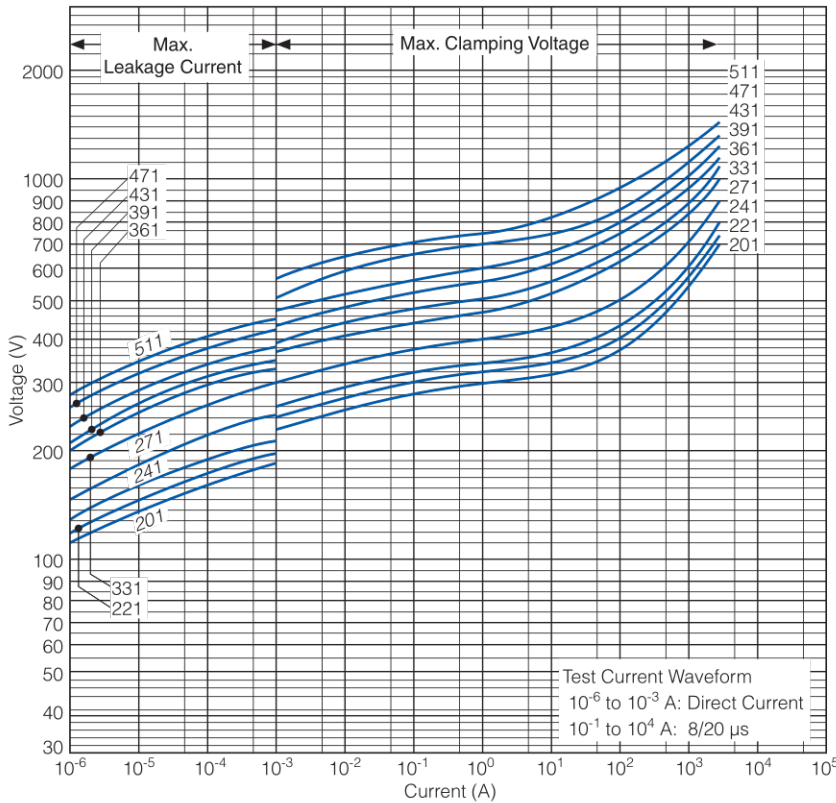

Impulse Derating (Relation between impulse width and impulse current multiple)

ERZE08A201 to ERZE08A511

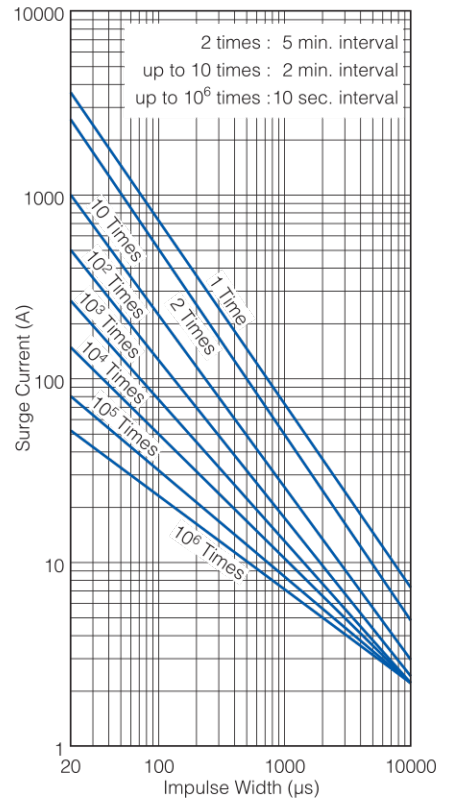

ERZE08A561 to ERZE08A751

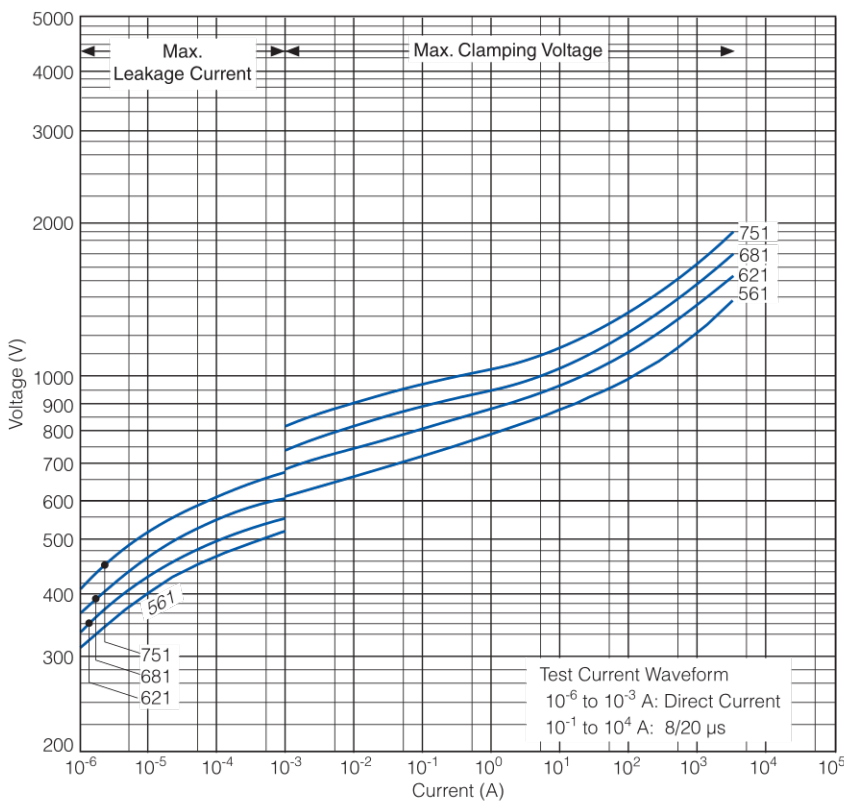

ERZE08A561 to ERZE08A751

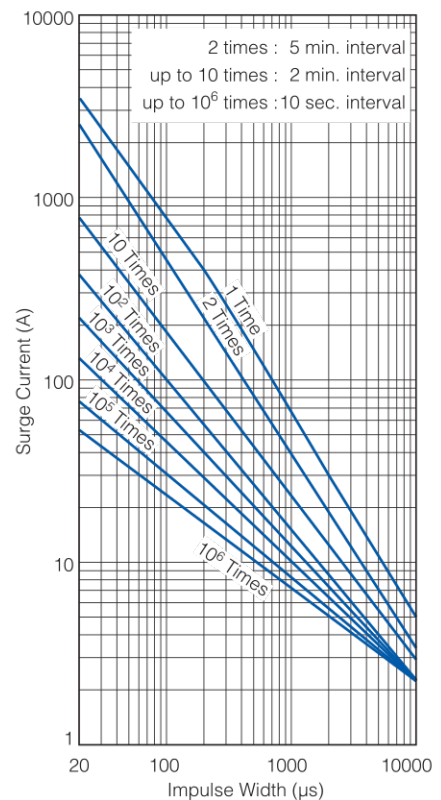

Series E10

Ratings and Characteristics

● Operating Temperature Range : -40 to 85 °C ● Storage Temperature Range : -40 to 125 °C

Part No.	Varistor Voltage $V_{1\text{mA}}$ (V)	Maximum Allowable Voltage		Clamping Voltage (max.) *I _p (V)	Rated Power (W)	Maximum Energy		Maximum Peak Current (8/20 μs)		Capacitance (max.) at 1 kHz (pF)
		ACrms (V)	DC (V)			(10/1000 μs)	(2 ms)	1 time	2 times	
						(J)	(J)	(A)	(A)	
ERZE10A201	200(185 to 225)	130	170	340	0.5	47	34	4500	3000	630
ERZE10A221	220(198 to 242)	140	180	360	0.5	50	36	4500	3000	600
ERZE10A241	240(216 to 264)	150	200	395	0.5	56	40	4500	3000	570
ERZE10A271	270(247 to 303)	175	225	455	0.5	64	46	4500	3000	530
ERZE10A331	330(297 to 363)	210	270	545	0.5	72	52	4500	3000	470
ERZE10A361	360(324 to 396)	230	300	595	0.5	84	60	4500	3000	430
ERZE10A391	390(351 to 429)	250	320	650	0.5	91	65	4500	3000	400
ERZE10A431	430(387 to 473)	275	350	710	0.5	99	71	4500	3000	350
ERZE10A471	470(423 to 517)	300	385	775	0.5	106	76	4500	3000	320
ERZE10A511	510(459 to 561)	320	410	845	0.5	117	84	4500	3000	300
ERZE10A561	560(504 to 616)	350	450	930	0.5	120	86	4500	3000	290
ERZE10A621	620(558 to 682)	385	505	1025	0.5	126	88	4500	3000	280
ERZE10A681	680(612 to 748)	420	560	1120	0.5	133	95	4500	3000	260
ERZE10A751	750(675 to 825)	460	615	1240	0.5	140	100	4500	3000	250
ERZE10A821	820(738 to 902)	510	670	1355	0.5	154	110	4500	3000	230
ERZE10A911	910(819 to 1001)	550	745	1500	0.5	168	112	4500	3000	220
ERZE10A102	1000(900 to 1100)	625	825	1650	0.5	182	130	4500	3000	200
ERZE10A112	1100(990 to 1210)	680	895	1815	0.5	196	140	4500	3000	180

*I_p Measuring current of clamping voltage : 50 A

Dimensions in mm (not to scale)

Part No.	D max.	T max.	F±1.0	A max.	L±1.0
ERZE10A201	11.5	5.3	7.5	15.0	2.1
ERZE10A221	11.5	5.4	7.5	15.0	2.3
ERZE10A241	11.5	5.5	7.5	15.0	2.4
ERZE10A271	11.5	5.7	7.5	15.0	2.5
ERZE10A331	11.5	6.0	7.5	15.0	2.8
ERZE10A361	11.5	6.2	7.5	15.0	2.9
ERZE10A391	11.5	6.3	7.5	15.0	3.0
ERZE10A431	11.5	6.5	7.5	15.0	3.1
ERZE10A471	11.5	6.8	7.5	15.0	3.3
ERZE10A511	11.5	7.0	7.5	15.0	3.5
ERZE10A561	11.5	7.4	7.5	15.0	3.8
ERZE10A621	12.5	7.8	7.5	16.0	4.0
ERZE10A681	12.5	8.1	7.5	16.0	4.2
ERZE10A751	12.5	8.6	7.5	16.0	4.6
ERZE10A821	12.5	8.9	7.5	16.0	5.0
ERZE10A911	12.5	9.5	7.5	16.0	5.7
ERZE10A102	12.5	10.0	7.5	16.0	6.2
ERZE10A112	12.5	10.6	7.5	16.0	6.8

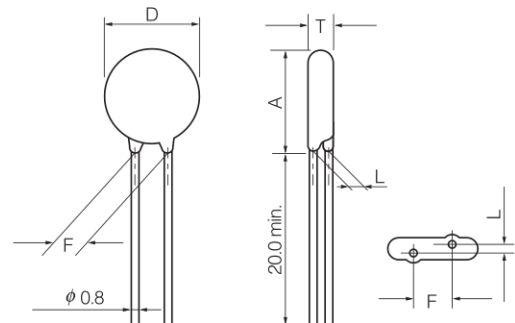

Typical Characteristics

Voltage vs. Current

ERZE10A201 to ERZE10A561

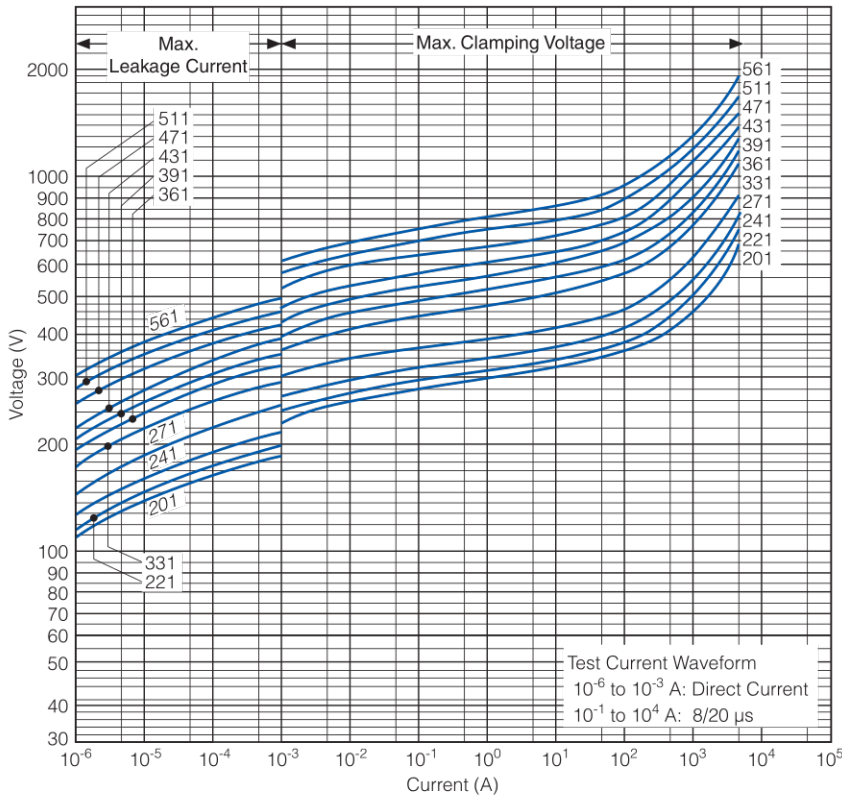

Impulse Derating (Relation between impulse width and impulse current multiple)

ERZE10A201 to ERZE10A561

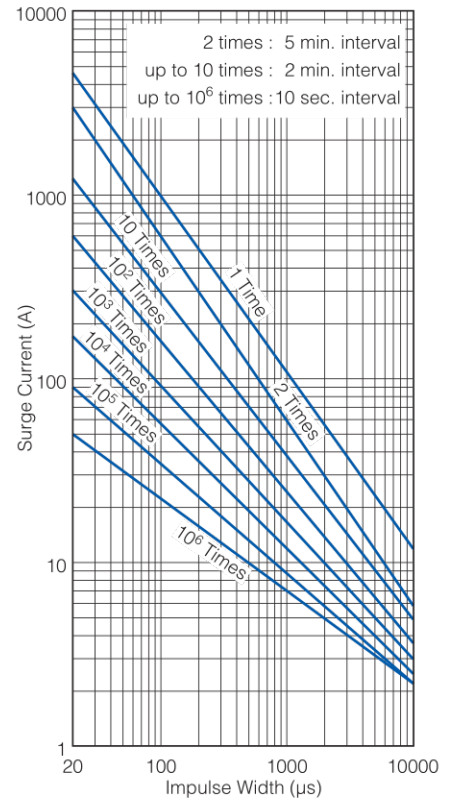

ERZE10A621 to ERZE10A112

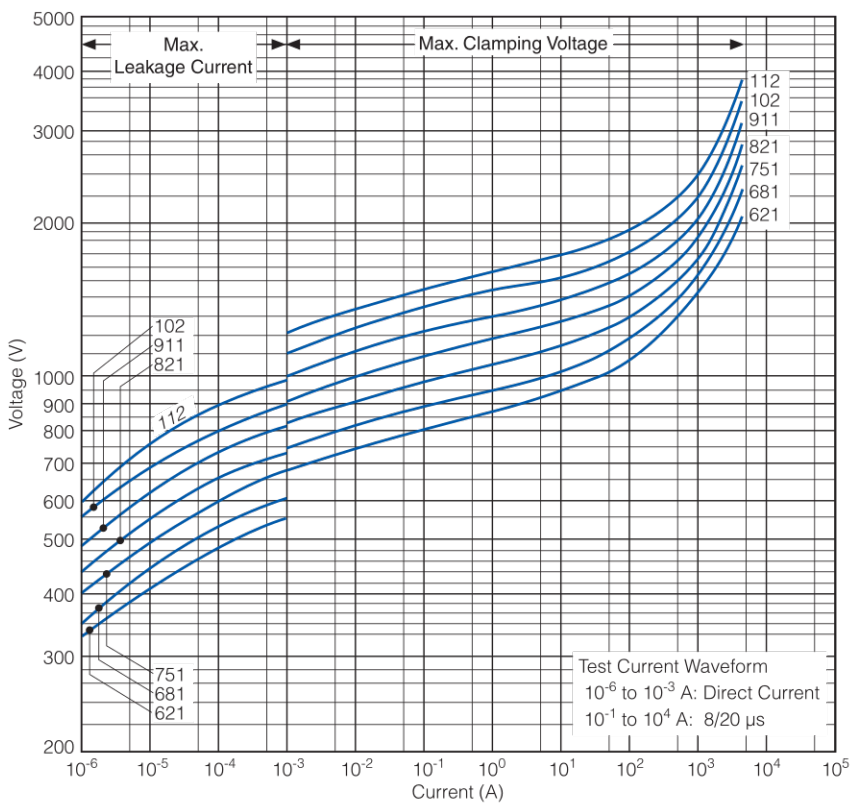

ERZE10A621 to ERZE10A112

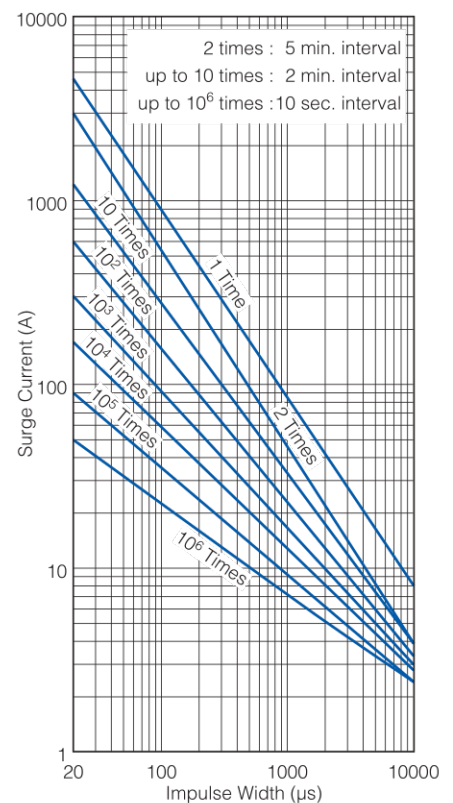

Series E11

Ratings and Characteristics

● Operating Temperature Range : -40 to 85 °C ● Storage Temperature Range : -40 to 125 °C

Part No.	Varistor Voltage $V_{1\text{mA}}$ (V)	Maximum Allowable Voltage		Clamping Voltage (max.) *Ip (V)	Rated Power (W)	Maximum Energy		Maximum Peak Current (8/20 μ s)		Capacitance (max.) at 1 kHz (pF)
		ACrms (V)	DC (V)			(10/1000 μ s)	(2 ms)	1 time	2 times	
						(J)	(J)	(A)	(A)	
ERZE11A201	200(185 to 225)	130	170	340	0.6	70	50	6000	5000	690
ERZE11A221	220(198 to 242)	140	180	360	0.6	78	55	6000	5000	660
ERZE11A241	240(216 to 264)	150	200	395	0.6	84	60	6000	5000	620
ERZE11A271	270(247 to 303)	175	225	455	0.6	99	70	6000	5000	580
ERZE11A331	330(297 to 363)	210	270	545	0.6	115	80	6000	4500	520
ERZE11A361	360(324 to 396)	230	300	595	0.6	130	90	6000	4500	480
ERZE11A391	390(351 to 429)	250	320	650	0.6	140	100	6000	4500	450
ERZE11A431	430(387 to 473)	275	350	710	0.6	155	110	6000	4500	400
ERZE11A471	470(423 to 517)	300	385	775	0.6	175	125	6000	4500	360
ERZE11A511	510(459 to 561)	320	410	845	0.6	190	136	6000	4500	310
ERZE11A561	560(504 to 616)	350	450	930	0.6	190	136	6000	4500	310
ERZE11A621	620(558 to 682)	385	505	1025	0.6	190	136	5000	4500	300
ERZE11A681	680(612 to 748)	420	560	1120	0.6	190	136	5000	4500	290
ERZE11A751	750(675 to 825)	460	615	1240	0.6	210	150	5000	4500	280
ERZE11A821	820(738 to 902)	510	670	1355	0.6	235	165	5000	4500	260
ERZE11A911	910(819 to 1001)	550	745	1500	0.6	255	180	5000	4500	240
ERZE11A102	1000(900 to 1100)	625	825	1650	0.6	280	200	5000	4500	220
ERZE11A112	1100(990 to 1210)	680	895	1815	0.6	310	220	5000	4500	200

*Ip Measuring current of clamping voltage : 50 A

Dimensions in mm (not to scale)

Part No.	D max.	T max.	F \pm 1.0	A max.	L \pm 1.0
ERZE11A201	13.0	5.2	7.5	17.0	1.9
ERZE11A221	13.0	5.3	7.5	17.0	2.0
ERZE11A241	13.0	5.4	7.5	17.0	2.1
ERZE11A271	13.0	5.6	7.5	17.0	2.3
ERZE11A331	13.0	5.9	7.5	17.0	2.6
ERZE11A361	13.0	6.1	7.5	17.0	2.8
ERZE11A391	13.0	6.2	7.5	17.0	2.9
ERZE11A431	13.0	6.4	7.5	17.0	3.1
ERZE11A471	13.0	6.6	7.5	17.0	3.3
ERZE11A511	13.0	6.8	7.5	17.0	3.5
ERZE11A561	13.0	7.2	7.5	17.0	3.8
ERZE11A621	14.0	7.5	7.5	18.0	4.2
ERZE11A681	14.0	7.8	7.5	18.0	4.5
ERZE11A751	14.0	8.2	7.5	18.0	4.9
ERZE11A821	14.0	8.5	7.5	18.0	5.2
ERZE11A911	14.0	9.0	7.5	18.0	5.7
ERZE11A102	14.0	9.5	7.5	18.0	6.2
ERZE11A112	14.0	10.1	7.5	18.0	6.8

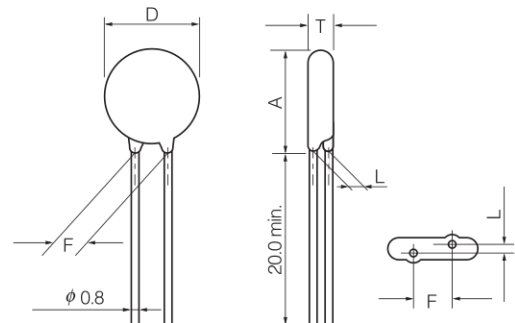

Typical Characteristics

Voltage vs. Current

ERZE11A201 to ERZE11A511

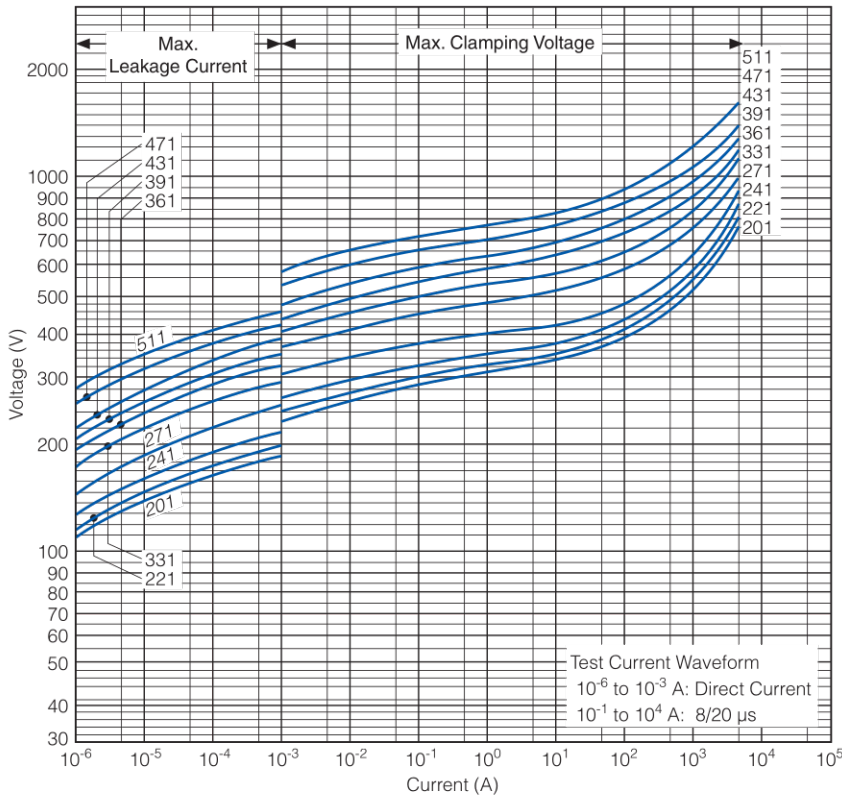

Impulse Derating (Relation between impulse width and impulse current multiple)

ERZE11A201 to ERZE11A511

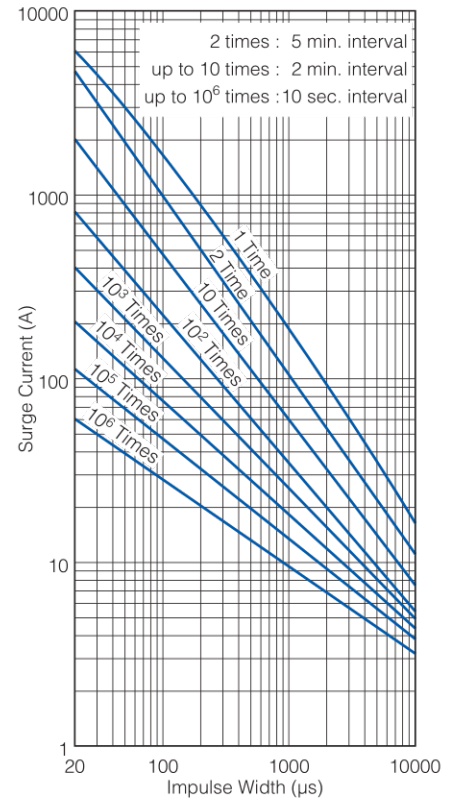

ERZE11A561 to ERZE11A112

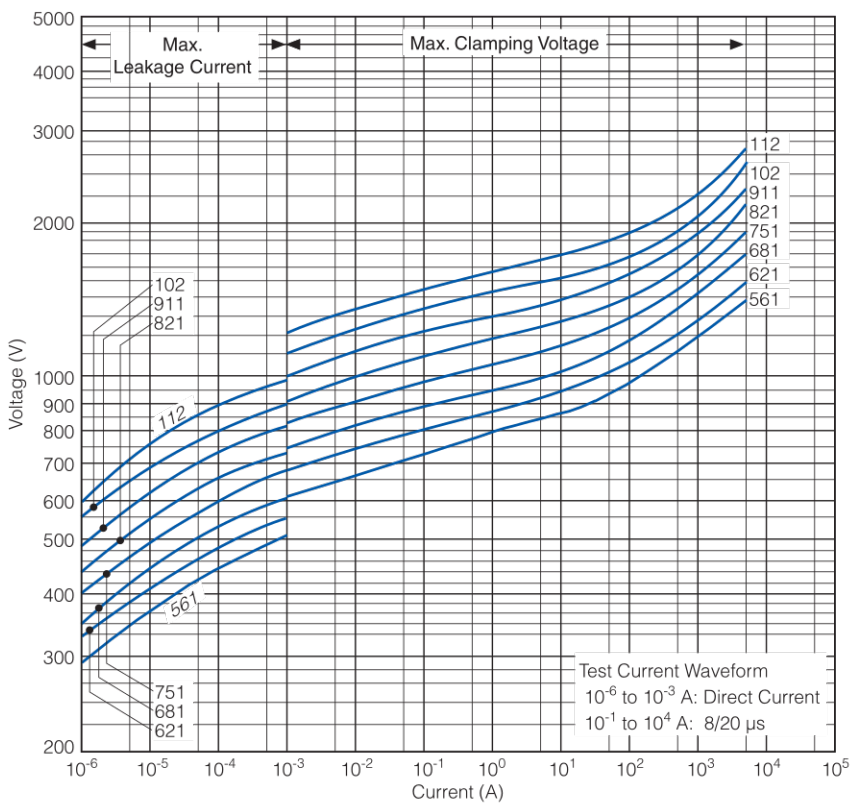

ERZE11A561 to ERZE11A112

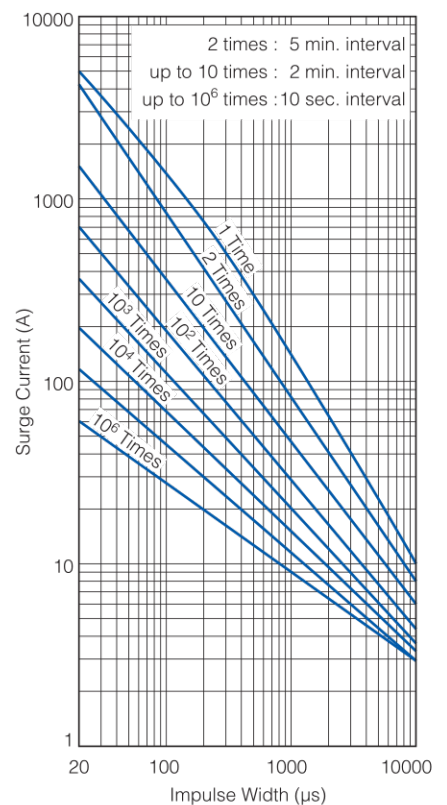

Series E14

Ratings and Characteristics

● Operating Temperature Range : -40 to 85 °C ● Storage Temperature Range : -40 to 125 °C

Part No.	Varistor Voltage $V_{1\text{mA}}$ (V)	Maximum Allowable Voltage		Clamping Voltage (max.) *I _p (V)	Rated Power (W)	Maximum Energy		Maximum Peak Current (8/20 μs)		Capacitance (max.) at 1 kHz (pF)
		ACrms (V)	DC (V)			(10/1000 μs)	(2 ms)	1 time	2 times	
						(J)	(J)	(A)	(A)	
ERZE14A201	200(185 to 225)	130	170	340	1.0	140	100	10000	7000	1300
ERZE14A221	220(198 to 242)	140	180	360	1.0	155	110	10000	7000	1200
ERZE14A241	240(216 to 264)	150	200	395	1.0	168	120	10000	7000	1100
ERZE14A271	270(247 to 303)	175	225	455	1.0	190	135	10000	7000	1000
ERZE14A331	330(297 to 363)	210	270	545	1.0	228	160	10000	6500	900
ERZE14A361	360(324 to 396)	230	300	595	1.0	255	180	10000	6500	900
ERZE14A391	390(351 to 429)	250	320	650	1.0	275	195	10000	6500	800
ERZE14A431	430(387 to 473)	275	350	710	1.0	303	215	10000	6500	800
ERZE14A471	470(423 to 517)	300	385	775	1.0	350	250	10000	6500	750
ERZE14A511	510(459 to 561)	320	410	845	1.0	382	273	10000	6500	700
ERZE14A561	560(504 to 616)	350	450	930	1.0	382	273	10000	6500	700
ERZE14A621	620(558 to 682)	385	505	1025	1.0	382	273	7500	6500	650
ERZE14A681	680(612 to 748)	420	560	1120	1.0	382	273	7500	6500	600
ERZE14A751	750(675 to 825)	460	615	1240	1.0	420	300	7500	6500	530
ERZE14A821	820(738 to 902)	510	670	1355	1.0	460	325	7500	6500	500
ERZE14A911	910(819 to 1001)	550	745	1500	1.0	510	360	7500	6500	400
ERZE14A102	1000(900 to 1100)	625	825	1650	1.0	565	400	7500	6500	400
ERZE14A112	1100(990 to 1210)	680	895	1815	1.0	620	440	7500	6500	350

*I_p Measuring current of clamping voltage : 100 A

Dimensions in mm (not to scale)

Part No.	D max.	T max.	F±1.0	A max.	L±1.0
ERZE14A201	16.5	5.2	10.0	20.0	2.1
ERZE14A221	16.5	5.3	10.0	20.0	2.2
ERZE14A241	16.5	5.4	10.0	20.0	2.3
ERZE14A271	16.5	5.6	10.0	20.0	2.5
ERZE14A331	16.5	5.9	10.0	20.0	2.8
ERZE14A361	16.5	6.1	10.0	20.0	3.0
ERZE14A391	16.5	6.2	10.0	20.0	3.1
ERZE14A431	16.5	6.4	10.0	20.0	3.3
ERZE14A471	16.5	6.6	10.0	20.0	3.5
ERZE14A511	16.5	6.8	10.0	20.0	3.7
ERZE14A561	16.5	7.2	10.0	20.0	4.0
ERZE14A621	17.5	7.5	10.0	20.5	4.4
ERZE14A681	17.5	7.8	10.0	20.5	4.7
ERZE14A751	17.5	8.2	10.0	20.5	5.1
ERZE14A821	17.5	8.5	10.0	20.5	5.4
ERZE14A911	17.5	9.0	10.0	20.5	5.9
ERZE14A102	17.5	9.5	10.0	20.5	6.4
ERZE14A112	17.5	10.1	10.0	20.5	7.2

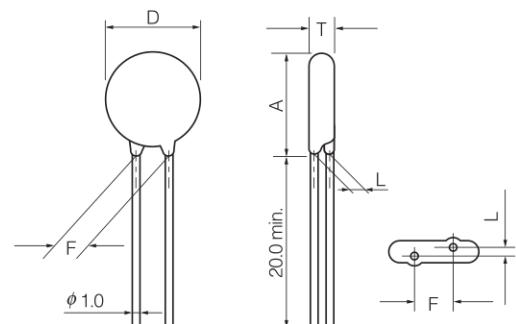

Typical Characteristics

Voltage vs. Current

ERZE14A201 to ERZE14A511

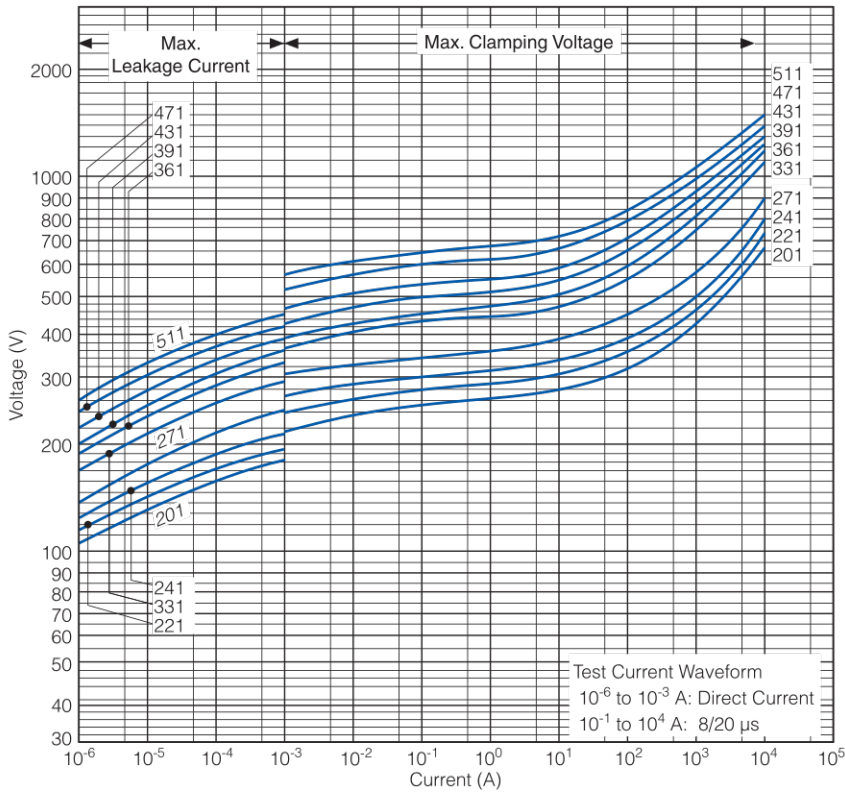

Impulse Derating (Relation between impulse width and impulse current multiple)

ERZE14A201 to ERZE14A511

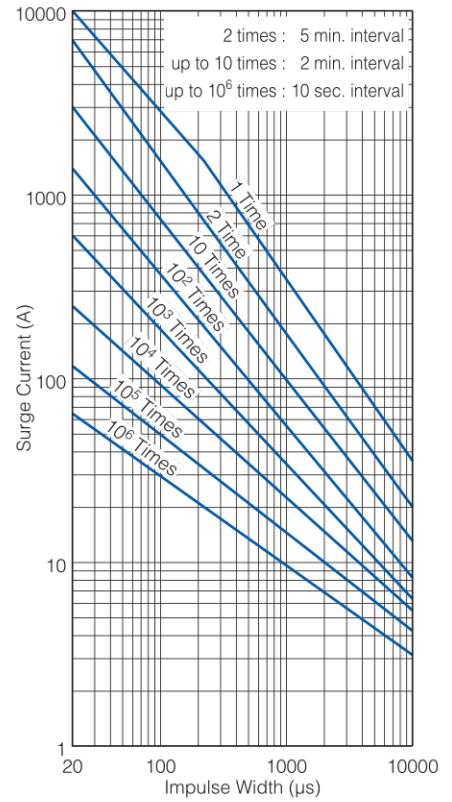

ERZE14A561 to ERZE14A112

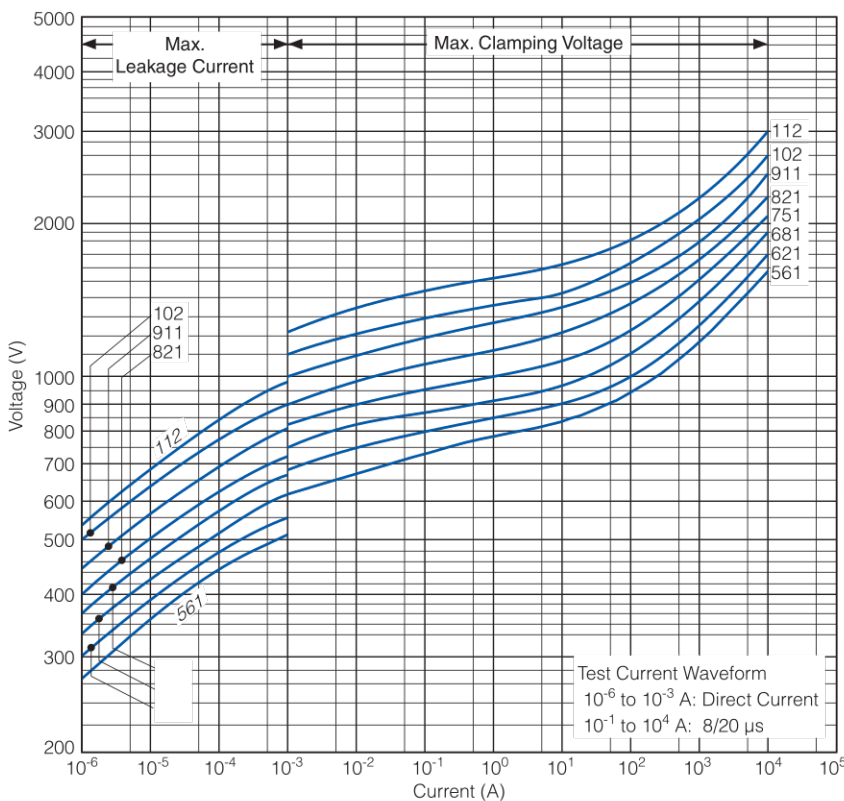

ERZE14A561 to ERZE14A112

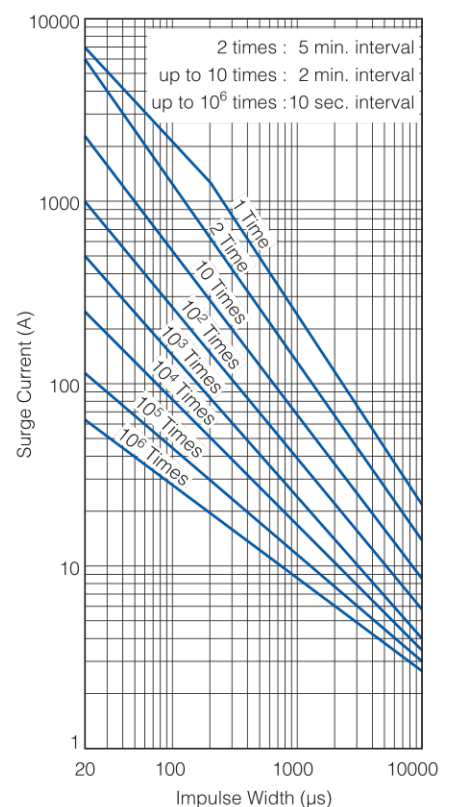

Straight Leads Cut Type (Bulk Type)

Ratings and Characteristics

* Refer to bulk standard type part no. (P34 to P43).

Dimensions in mm (not to scale)

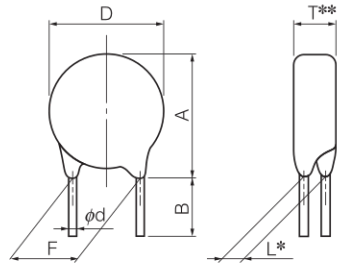

notes * Dimension “L”: Conforms to each individual specification.
 ** Dimension “T”: Conforms to each individual specification.

Unit : mm

Series	E5	E7		E8		E10		E11			
Symbol	Varistor Voltage	201 to 471	201 to 511	561	621	201 to 561	621 to 751	201 to 561	621 to 112	201 to 561	621 to 112
D		7.0 max.	9.0 max.	9.0 max.	10.0 max.	10.5 max.	11.5 max.	11.5 max.	12.5 max.	13.0 max.	14.0 max.
A		10.0 max.	12.5 max.	13.5 max.	13.5 max.	13.5 max.	14.5 max.	15.0 max.	16.0 max.	17.0 max.	18.0 max.
F		5.0±1.0	7.5±1.0	7.5±1.0	7.5±1.0	7.5±1.0	7.5±1.0	7.5±1.0	7.5±1.0	7.5±1.0	7.5±1.0
ϕd		0.60 ^{+0.06} _{-0.05}	0.80 ^{+0.08} _{-0.05}	0.80 ^{+0.08} _{-0.05}	0.80 ^{+0.08} _{-0.05}	0.80 ^{+0.08} _{-0.05}	0.80 ^{+0.08} _{-0.05}	0.80 ^{+0.08} _{-0.05}	0.80 ^{+0.08} _{-0.05}	0.80 ^{+0.08} _{-0.05}	0.80 ^{+0.08} _{-0.05}
B		4.0±1.0	4.0±1.0	4.0±1.0	4.0±1.0	4.0±1.0	4.0±1.0	4.0±1.0	4.0±1.0	4.0±1.0	4.0±1.0
Standard Products Part No.		ERZE05A□□□CS	ERZE07A□□□CS		ERZE08A□□□CS		ERZE10A□□□CS		ERZE11A□□□CS		

Crimped Leads Cut Type (Bulk Type)

Ratings and Characteristics

* Refer to bulk standard type part no. (P34 to P43).

Dimensions in mm (not to scale)

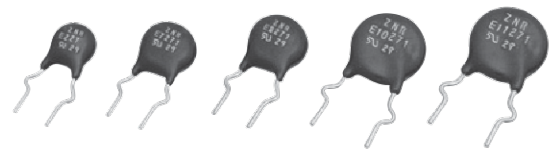
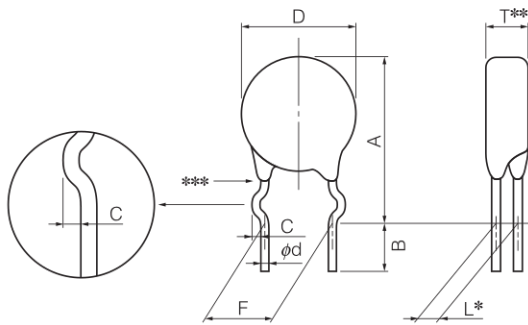

notes * Dimension “L”: Conforms to each individual specification.
 ** Dimension “T”: Conforms to each individual specification.
 *** Resin extensions : No resin below the center of the hook.

Unit : mm

Series	E5	E7		E8		E10			E11			
Symbol	Varistor Voltage	201 to 471	201 to 511	561	621	201 to 561	621 to 751	201 to 561	621 to 681	751 to 112	201 to 561	621 to 112
D		7.0 max.	9.0 max.	9.0 max.	10.0 max.	10.5 max.	11.5 max.	11.5 max.	12.5 max.	12.5 max.	13.0 max.	14.0 max.
A		13.0 max.	15.5 max.	16.5 max.	16.5 max.	17.0 max.	18.0 max.	18.0 max.	19.5 max.	20.5 max.	20.5 max.	21.5 max.
C		1.2±0.4	1.4±0.4	1.4±0.4	1.4±0.4	1.4±0.4	1.4±0.4	1.4±0.4	1.4±0.4	1.4±0.4	1.4±0.4	1.4±0.4
F		5.0±1.0	7.5±1.0	7.5±1.0	7.5±1.0	7.5±1.0	7.5±1.0	7.5±1.0	7.5±1.0	7.5±1.0	7.5±1.0	7.5±1.0
ϕd		0.60 ^{+0.06} _{-0.05}	0.80 ^{+0.08} _{-0.05}	0.80 ^{+0.08} _{-0.05}	0.80 ^{+0.08} _{-0.05}	0.80 ^{+0.08} _{-0.05}	0.80 ^{+0.08} _{-0.05}	0.80 ^{+0.08} _{-0.05}	0.80 ^{+0.08} _{-0.05}	0.80 ^{+0.08} _{-0.05}	0.80 ^{+0.08} _{-0.05}	0.80 ^{+0.08} _{-0.05}
B		4.0±1.0	4.0±1.0	4.0±1.0	4.0±1.0	4.0±1.0	4.0±1.0	4.0±1.0	4.0±1.0	4.0±1.0	4.0±1.0	4.0±1.0
Standard Products Part No.		ERZE05B□□□CS	ERZE07B□□□CS		ERZE08B□□□CS		ERZE10B□□□CS			ERZE11B□□□CS		

Design and specifications are each subject to change without notice. Ask factory for the current technical specifications before purchase and/or use.
 Should a safety concern arise regarding this product, please be sure to contact us immediately.

Taping Specifications for Automated Assembly (Straight Leads and Taping)

Ratings and Characteristics

* Refer to bulk standard type part no. (P34 to P43).

Taping Dimensions in mm (not to scale)

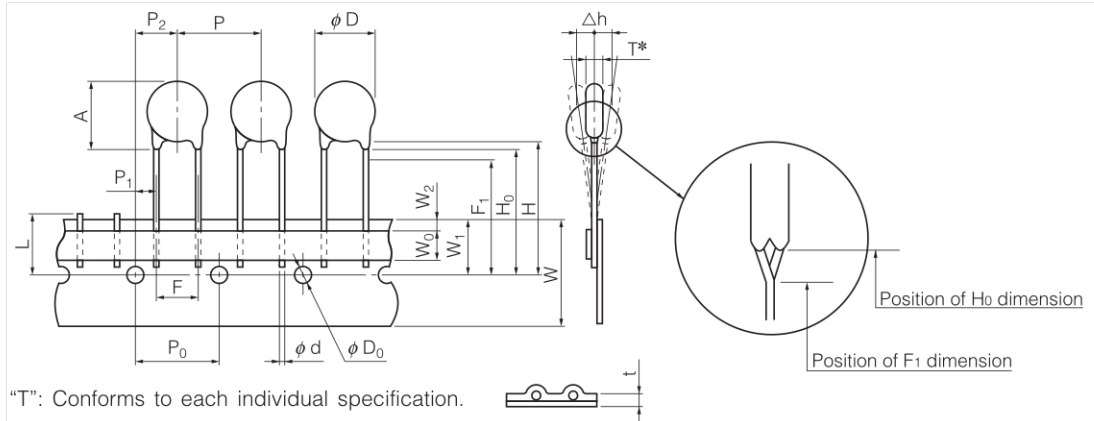

Unit : mm

Series	E5		E7				E8			E10			E11		
Symbol	Varistor Voltage	201 to 471	201 to 271	331 to 551	561	621	201 to 221	241 to 561	621 to 751	201 to 221	241 to 561	621 to 112	201 to 221	241 to 561	621 to 112
P		12.7±1.0	15.0±1.0	15.0±1.0	15.0±1.0	15.0±1.0	15.0±1.0	15.0±1.0	15.0±1.0	15.0±1.0	15.0±1.0	15.0±1.0	15.0±1.0	15.0±1.0	15.0±1.0
P ₀		12.7±0.3	15.0±0.3	15.0±0.3	15.0±0.3	15.0±0.3	15.0±0.3	15.0±0.3	15.0±0.3	15.0±0.3	15.0±0.3	15.0±0.3	15.0±0.3	15.0±0.3	15.0±0.3
P ₁		3.85±0.70	3.75±0.70	3.75±0.70	3.75±0.70	3.75±0.70	3.75±0.70	3.75±0.70	3.75±0.70	3.75±0.70	3.75±0.70	3.75±0.70	3.75±0.70	3.75±0.70	3.75±0.70
P ₂		6.36±1.30	7.5±1.3	7.5±1.3	7.5±1.3	7.5±1.3	7.5±1.3	7.5±1.3	7.5±1.3	7.5±1.3	7.5±1.3	7.5±1.3	7.5±1.3	7.5±1.3	7.5±1.3
φd		0.60 ^{+0.08} _{-0.05}	0.80 ^{+0.08} _{-0.05}	0.80 ^{+0.08} _{-0.05}	0.80 ^{+0.08} _{-0.05}	0.80 ^{+0.08} _{-0.05}	0.80 ^{+0.08} _{-0.05}	0.80 ^{+0.08} _{-0.05}	0.80 ^{+0.08} _{-0.05}	0.80 ^{+0.08} _{-0.05}	0.80 ^{+0.08} _{-0.05}	0.80 ^{+0.08} _{-0.05}	0.80 ^{+0.08} _{-0.05}	0.80 ^{+0.08} _{-0.05}	0.80 ^{+0.08} _{-0.05}
F		5.0±0.5	7.5±0.5	7.5±0.5	7.5±0.5	7.5±0.5	7.5±0.5	7.5±0.5	7.5±0.5	7.5±0.5	7.5±0.5	7.5±0.5	7.5±0.5	7.5±0.5	7.5±0.5
Δh		0±2	0±2	0±2	0±2	0±2	0±2	0±2	0±2	0±2	0±2	0±2	0±2	0±2	0±2
W		18.0 ^{+1.0} _{-0.5}	18.0 ^{+1.0} _{-0.5}	18.0 ^{+1.0} _{-0.5}	18.0 ^{+1.0} _{-0.5}	18.0 ^{+1.0} _{-0.5}	18.0 ^{+1.0} _{-0.5}	18.0 ^{+1.0} _{-0.5}	18.0 ^{+1.0} _{-0.5}	18.0 ^{+1.0} _{-0.5}	18.0 ^{+1.0} _{-0.5}	18.0 ^{+1.0} _{-0.5}	18.0 ^{+1.0} _{-0.5}	18.0 ^{+1.0} _{-0.5}	18.0 ^{+1.0} _{-0.5}
W ₀		5.0 min.	5.0 min.	5.0 min.	5.0 min.	5.0 min.	5.0 min.	5.0 min.	5.0 min.	5.0 min.	5.0 min.	5.0 min.	5.0 min.	5.0 min.	5.0 min.
W ₁		9.0±0.5	9.0±0.5	9.0±0.5	9.0±0.5	9.0±0.5	9.0±0.5	9.0±0.5	9.0±0.5	9.0±0.5	9.0±0.5	9.0±0.5	9.0±0.5	9.0±0.5	9.0±0.5
W ₂		3.0 max.	3.0 max.	3.0 max.	3.0 max.	3.0 max.	3.0 max.	3.0 max.	3.0 max.	3.0 max.	3.0 max.	3.0 max.	3.0 max.	3.0 max.	3.0 max.
H		Approx. 22	Approx. 22	Approx. 22	Approx. 22	Approx. 22	Approx. 22	Approx. 22	Approx. 22	Approx. 22	Approx. 22	Approx. 22	Approx. 22	Approx. 22	Approx. 22
H ₀		17.0±0.5	18.0 ^{+2.0} ₀	—	—	—	18.0 ^{+2.0} ₀	—	—	18.0 ^{+2.0} ₀	—	—	18.0 ^{+2.0} ₀	—	—
F ₁		—	—	16.00 ^{+0.75} _{-0.50}	16.00 ^{+0.75} _{-0.50}	16.00 ^{+0.75} _{-0.50}	—	16.00 ^{+0.75} _{-0.50}	16.00 ^{+0.75} _{-0.50}	—	16.00 ^{+0.75} _{-0.50}	16.00 ^{+0.75} _{-0.50}	—	16.00 ^{+0.75} _{-0.50}	16.00 ^{+0.75} _{-0.50}
φD ₀		φ 4.0±0.2	φ 4.0±0.2	φ 4.0±0.2	φ 4.0±0.2	φ 4.0±0.2	φ 4.0±0.2	φ 4.0±0.2	φ 4.0±0.2	φ 4.0±0.2	φ 4.0±0.2	φ 4.0±0.2	φ 4.0±0.2	φ 4.0±0.2	φ 4.0±0.2
t		0.6±0.3	0.6±0.3	0.6±0.3	0.6±0.3	0.6±0.3	0.6±0.3	0.6±0.3	0.6±0.3	0.6±0.3	0.6±0.3	0.6±0.3	0.6±0.3	0.6±0.3	0.6±0.3
L		11.0 max.	11.0 max.	11.0 max.	11.0 max.	11.0 max.	11.0 max.	11.0 max.	11.0 max.	11.0 max.	11.0 max.	11.0 max.	11.0 max.	11.0 max.	11.0 max.
φD		7.0 max.	9.0 max.	9.0 max.	9.0 max.	10.5 max.	10.5 max.	10.5 max.	11.5 max.	11.5 max.	11.5 max.	12.5 max.	13.0 max.	13.0 max.	14.0 max.
A		10.0 max.	12.5 max.	12.5 max.	13.5 max.	13.5 max.	13.5 max.	13.5 max.	14.5 max.	15.0 max.	15.0 max.	16.0 max.	17.0 max.	17.0 max.	18.0 max.
Standard Products Part No.		ERZE05E□□□	ERZE07E□□□□				ERZE08E□□□□			ERZE10E□□□□			ERZE11E□□□□		

Design and specifications are each subject to change without notice. Ask factory for the current technical specifications before purchase and/or use.

Should a safety concern arise regarding this product, please be sure to contact us immediately.

05 Apr. 2017

Taping Specifications for Automated Assembly (Crimped Leads and Taping)

Ratings and Characteristics

* Refer to bulk standard type part no. (P34 to P43).

Taping Dimensions in mm (not to scale)

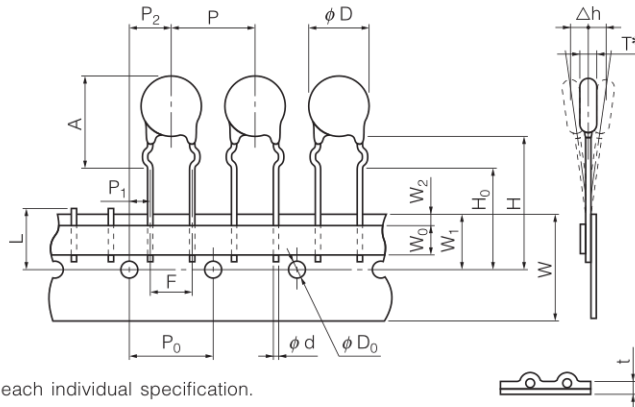

* Dimension “T”: Conforms to each individual specification.

Unit : mm

Series	E5			E7			E8			E10			E11		
Symbol	201 to 471	201 to 511	561	621	201 to 221	241 to 561	621 to 751	201 to 561	621 to 681	751 to 112	201 to 221	241 to 561	621 to 112		
P	12.7±1.0	15.0±1.0	15.0±1.0	15.0±1.0	15.0±1.0	15.0±1.0	15.0±1.0	15.0±1.0	15.0±1.0	15.0±1.0	15.0±1.0	15.0±1.0	15.0±1.0		
P ₀	12.7±0.3	15.0±0.3	15.0±0.3	15.0±0.3	15.0±0.3	15.0±0.3	15.0±0.3	15.0±0.3	15.0±0.3	15.0±0.3	15.0±0.3	15.0±0.3	15.0±0.3		
P ₁	3.85±0.70	3.75±0.70	3.75±0.70	3.75±0.70	3.75±0.70	3.75±0.70	3.75±0.70	3.75±0.70	3.75±0.70	3.75±0.70	3.75±0.70	3.75±0.70	3.75±0.70		
P ₂	6.35±1.30	7.5±1.3	7.5±1.3	7.5±1.3	7.5±1.3	7.5±1.3	7.5±1.3	7.5±1.3	7.5±1.3	7.5±1.3	7.5±1.3	7.5±1.3	7.5±1.3		
φd	0.60 ^{+0.06} _{-0.05}	0.80 ^{+0.08} _{-0.05}	0.80 ^{+0.08} _{-0.05}	0.80 ^{+0.08} _{-0.05}	0.80 ^{+0.08} _{-0.05}	0.80 ^{+0.08} _{-0.05}	0.80 ^{+0.08} _{-0.05}	0.80 ^{+0.08} _{-0.05}	0.80 ^{+0.08} _{-0.05}	0.80 ^{+0.08} _{-0.05}	0.80 ^{+0.08} _{-0.05}	0.80 ^{+0.08} _{-0.05}	0.80 ^{+0.08} _{-0.05}		
F	5.0±0.5	7.5±0.5	7.5±0.5	7.5±0.5	7.5±0.5	7.5±0.5	7.5±0.5	7.5±0.5	7.5±0.5	7.5±0.5	7.5±0.5	7.5±0.5	7.5±0.5		
Δh	0±2	0±2	0±2	0±2	0±2	0±2	0±2	0±2	0±2	0±2	0±2	0±2	0±2		
W	18.0 ^{+1.0} _{-0.5}	18.0 ^{+1.0} _{-0.5}	18.0 ^{+1.0} _{-0.5}	18.0 ^{+1.0} _{-0.5}	18.0 ^{+1.0} _{-0.5}	18.0 ^{+1.0} _{-0.5}	18.0 ^{+1.0} _{-0.5}	18.0 ^{+1.0} _{-0.5}	18.0 ^{+1.0} _{-0.5}	18.0 ^{+1.0} _{-0.5}	18.0 ^{+1.0} _{-0.5}	18.0 ^{+1.0} _{-0.5}	18.0 ^{+1.0} _{-0.5}		
W ₀	5.0 min.	5.0 min.	5.0 min.	5.0 min.	5.0 min.	5.0 min.	5.0 min.	5.0 min.	5.0 min.	5.0 min.	5.0 min.	5.0 min.	5.0 min.		
W ₁	9.0±0.5	9.0±0.5	9.0±0.5	9.0±0.5	9.0±0.5	9.0±0.5	9.0±0.5	9.0±0.5	9.0±0.5	9.0±0.5	9.0±0.5	9.0±0.5	9.0±0.5		
W ₂	3.0 max.	3.0 max.	3.0 max.	3.0 max.	3.0 max.	3.0 max.	3.0 max.	3.0 max.	3.0 max.	3.0 max.	3.0 max.	3.0 max.	3.0 max.		
H	Approx. 22	Approx. 22	Approx. 22	Approx. 22	Approx. 22	Approx. 22	Approx. 22	Approx. 22	Approx. 22	Approx. 22	Approx. 22	Approx. 22	Approx. 22		
H ₀	17.0±0.5	16.0±0.5	16.0±0.5	16.0±0.5	16.0±0.5	16.0±0.5	16.0±0.5	16.0±0.5	16.0±0.5	16.0±0.5	16.0±0.5	16.0±0.5	16.0±0.5		
φD ₀	φ 4.0±0.2	φ 4.0±0.2	φ 4.0±0.2	φ 4.0±0.2	φ 4.0±0.2	φ 4.0±0.2	φ 4.0±0.2	φ 4.0±0.2	φ 4.0±0.2	φ 4.0±0.2	φ 4.0±0.2	φ 4.0±0.2	φ 4.0±0.2		
t	0.6±0.3	0.6±0.3	0.6±0.3	0.6±0.3	0.6±0.3	0.6±0.3	0.6±0.3	0.6±0.3	0.6±0.3	0.6±0.3	0.6±0.3	0.6±0.3	0.6±0.3		
L	11.0 max.	11.0 max.	11.0 max.	11.0 max.	11.0 max.	11.0 max.	11.0 max.	11.0 max.	11.0 max.	11.0 max.	11.0 max.	11.0 max.	11.0 max.		
φD	7.0 max.	9.0 max.	9.0 max.	10.0 max.	10.5 max.	10.5 max.	11.5 max.	11.5 max.	12.5 max.	12.5 max.	13.0 max.	13.0 max.	14.0 max.		
A	13.0 max.	15.5 max.	16.5 max.	16.5 max.	17.0 max.	17.0 max.	18.0 max.	18.0 max.	19.5 max.	20.5 max.	20.5 max.	20.5 max.	21.5 max.		
Standard Products Part No.	ERZE05F□□□	ERZE07F□□□□			ERZE08F□□□□			ERZE10F□□□□			ERZE11F□□□□				

Design and specifications are each subject to change without notice. Ask factory for the current technical specifications before purchase and/or use.
Should a safety concern arise regarding this product, please be sure to contact us immediately.

Application Note for Safety Standards (For Series E)

- Approvals products lists in "Reference Guide to Standard Products"
- UL and VDE : Registered in "Type Name" , it isn't registered in "Panasonic Part No."
- CQC : Registered in "Panasonic Part No."
- "Rated Voltages" are specified for UL recognized components in list shown below.

The AC Rated Voltage and Maximum Allowable Voltage

Type Name	Maximum Allowable Voltage		Rated Voltage (Vrms)
	ACrms (V)	DC (V)	UL1449
E*201	130	170	118
E*221	140	180	127
E*241	150	200	136
E*271	175	225	159
E*331	210	270	189
E*361	230	300	209
E*391	250	320	227
E*431	275	350	250
E*471	300	385	272
E*511	320	410	291
E*561	350	450	320
E*621	385	505	350
E*681	420	560	381
E*751	460	615	418
E*821	510	670	463
E*911	550	745	500
E*102	625	825	568
E*112	680	895	600

*: 5 series is blank, 7 series is 7, 8 series is 8, 10 series is 10, 11 series is 11, 14 series is 14

Guidelines and precautions regarding the technical information and use of our products described in this online catalog.

- If you want to use our products described in this online catalog for applications requiring special qualities or reliability, or for applications where the failure or malfunction of the products may directly jeopardize human life or potentially cause personal injury (e.g. aircraft and aerospace equipment, traffic and transportation equipment, combustion equipment, medical equipment, accident prevention, anti-crime equipment, and/or safety equipment), it is necessary to verify whether the specifications of our products fit to such applications. Please ensure that you will ask and check with our inquiry desk as to whether the specifications of our products fit to such applications use before you use our products.
- The quality and performance of our products as described in this online catalog only apply to our products when used in isolation. Therefore, please ensure you evaluate and verify our products under the specific circumstances in which our products are assembled in your own products and in which our products will actually be used.
- If you use our products in equipment that requires a high degree of reliability, regardless of the application, it is recommended that you set up protection circuits and redundancy circuits in order to ensure safety of your equipment.
- The products and product specifications described in this online catalog are subject to change for improvement without prior notice. Therefore, please be sure to request and confirm the latest product specifications which explain the specifications of our products in detail, before you finalize the design of your applications, purchase, or use our products.
- The technical information in this online catalog provides examples of our products' typical operations and application circuits. We do not guarantee the non-infringement of third party's intellectual property rights and we do not grant any license, right, or interest in our intellectual property.
- If any of our products, product specifications and/or technical information in this online catalog is to be exported or provided to non-residents, the laws and regulations of the exporting country, especially with regard to security and export control, shall be observed.

<Regarding the Certificate of Compliance with the EU RoHS Directive/REACH Regulations>

- The switchover date for compliance with the RoHS Directive/REACH Regulations varies depending on the part number or series of our products.
- When you use the inventory of our products for which it is unclear whether those products are compliant with the RoHS Directive/REACH Regulation, please select "Sales Inquiry" in the website inquiry form and contact us.

We do not take any responsibility for the use of our products outside the scope of the specifications, descriptions, guidelines and precautions described in this online catalog.

"ZNR" Transient/Surge Absorbers, Type D, Series E, E-S1

Handling Precautions**⚠ Safety Precautions**

In case that a ZNR Surge Absorber (hereafter referred to as the ZNR, or product name) is used, if an abnormality takes place because of peripheral conditions of the ZNR(material, environments, power source conditions, circuit conditions, etc. in equipment design), fire, electric shock, burn, or product failure may be occur. The precautions for this product are described below, understand the content thoroughly before usage. For more questions, contact us.

If there's any uncertainty/doubt/products safety items, please contact us. When a dogma shall be occurred about safety for this products, be sure to inform us rapidly, operate your technical examination.

1. ⚠ Precautions to be strictly observed**1.1 Confirmation of performance ratings**

Use the ZNR within its rated range of performance such as the Max. allowable voltage, withstanding surge current, withstanding energy, impulse life(surge life), average pulse power, and operating temperature range. If used outside the range, the ZNR can be degrade and have element fracture, which may result in smoking and ignition.

1.2 To avoid accidents due to unexpected phenomena, take the following measures

- 1) In the event of fracture of the ZNR, its pieces may scatter ; hence, put the case or cover of the set product in place.
- 2) Do not install the ZNR near combustible substances(polyvinyl chloride wires, resin moldings, etc.).
If it is difficult to do, install a nonflammable cover.
- 3) Across-the-line use
When the ZNR is used across a line, put a current fuse in series with the ZNR(Refer to Item 2.1.1). (4) .
- 4) Use between line to ground
 - (1) If the case that the ZNR is used between a line to the ground, the short-circuit of the ZNR may not blow the current fuse because of grounding resistance, which may cause smoking and ignition of the ZNR's exterior resin.
As the measure against it, install an earth leakage breaker on the power supply side of the ZNR position. If no earth leakage breaker is installed, use a thermal fuse together with a current fuse in series. (Refer to Table 1.)
 - (2) If the case that the ZNR is used between a live part to metal case, an electric shock may develop at a shortcircuit of the ZNR ; hence, ground the metal case to the ground or keep it from the human body.

1.3 If ZNR is shorted out and happen smoke or ignition, please cut provided current to ZNR immediately.**2. Application notes****2.1 Pay attention to the following items to avoid the shortened life and failure of the ZNR**

- 1) Circuit conditions
 - (1) Select a ZNR of which the maximum voltage including fluctuations in source voltage allows for the maximum permissible circuit voltage. (Refer to Table 1.)
 - (2) In cases that surges are intermittently applied at short intervals(for example, in case that the voltage of the noise simulator test is implemented etc.), do not let them exceed the ZNR's rated power.
 - (3) Select a ZNR recommended in Table 1.
 - <1> Across-the-line use
If possible, use a Part No. marked with * in case of voltage temporarily rises load unbalance of separately-wired loads, short between hot and neutral-line, open of neutral line in single-phase-three-wired system, and due to resonance at switching for a capacitive, inductive load.

<2> Used between line to ground

Use a different Part No. from "Across-the-line use" as table 1, because of raising voltage in case of "Line to Ground Fault".

Use a Part No. marked with **in table 1, in case of the insulation resistance test(500 VDC) for equipment. When using a Part of the varistor voltage that the insulation efficiency examination can not be cleared, there is a case where the surge absorber can be done by removing it from the circuit depending on the circuit condition(Refer examination of Japan Domestic Safety Regulations).

Use a Part No. marked with *** in table 1, in case of the withstanding voltage test (1000 VAC or 1200 VAC) for equipment.

(4) Concerning current fuse

<1> We recommend selecting a ZNR and the rated current of a current fuse as follows.

Finally, please be sure that there is no danger if the ZNR mounted on the equipment breaks.

●Type D, Series E, E-S1

Standard Part No.	ERZE05A□□□□	ERZE07A□□□□	ERZE08A□□□□	ERZE10A□□□□	ERZE11A□□□□	ERZE14A□□□□
Fuse rated current	5 A max.	7 A max.	7 A max.	10 A max.	10 A max.	10 A max.

◆ Fuses shall use rated voltages appropriate for circuits.

<2> The recommended fuse position is shown in table 1, "Example of ZNR application", however, if the load current of protected equipment is larger than that of the above recommended fuse rated current, install a current fuse at the position shown below.

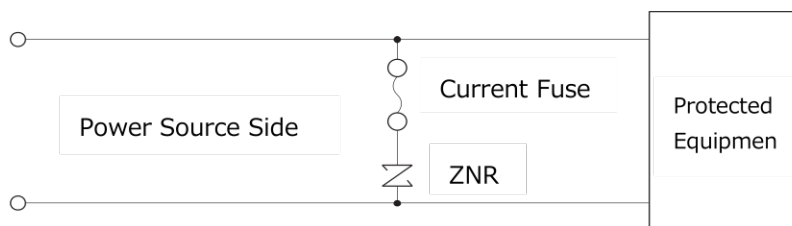

(5) Concerning thermal fuse

Set a thermal fuse to get high thermal

Table 1 Example of ZNR application

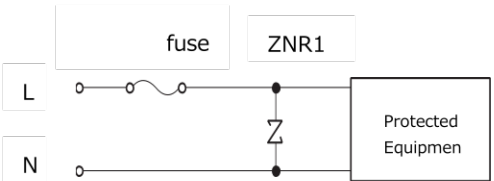
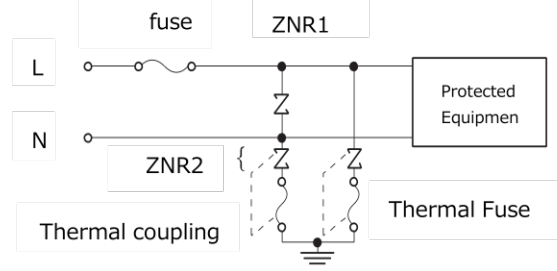
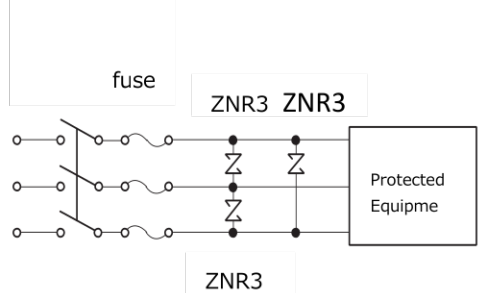
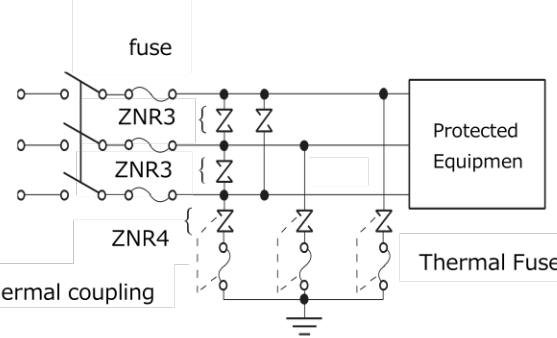
Connections example	Across-the-Line use		Use between Line to ground	
	DC/AC Single-phase 	DC/AC Single-phase 		
AC 3-phase 	AC 3-phase 			
Example of varistor voltage	ZNR	Source Voltage	Nominal varistor voltage	
	ZNR 1 ZNR 3	AC 100 V	201 to 361*	
AC 120 V		241 to 431*		
AC 200 V		471 to 621*		
AC 220 V		471 to 621*		
AC 380 V		751, 821*		
	ZNR	Source Voltage	Nominal varistor voltage	
ZNR 2 ZNR 4	AC 100 V AC 220 V	471	471	-
		511	-	-
	621*	-	-	
	821 and more**	-	-	
	AC 230 V AC 240 V AC 380 V	511	-	-
		621*	-	-
821 and more**		-	-	
	AC 380 V	112**	-	-

Note : Element size is selected by impulse Condition.

(6) On use for equipment

The catalog guarantees the quality as individual component.

Before you use the products, please make sure to check and evaluate the products in the circumstance where they are installed in your product.

2) Operating environments

- (1) The ZNR is designed to be used indoors. Do not use it exposed outdoors.
- (2) Do not use the ZNR in places exposed to temperatures beyond the operating temperature range, such as places exposed to sunlight and vicinities of heating equipment.
- (3) Do not use the ZNR in places exposed to high temperatures and high humidity, such as places exposed directly to rain, wind, dew condensation, and vapor.
- (4) Do not use the ZNR in dusty and salinity environment and atmospheres polluted by corrosive gases, in liquids such as water, oil, chemical, organic solvent.

3) Processing conditions

- (1) Do not wash the ZNR by such solvents(thinner, acetone, etc.) as its exterior resin deteriorates.
- (2) Do not apply a strong vibration or shock (by falling, etc.) to the ZNR, cracking to its exterior resin and element may occur.
- (3) When coating the ZNR with resin(including molding), do not use such resin.
- (4) Do not bend the ZNR type D lead wires at the position close to its ZNR type D exterior resin, or apply external force to the position.
- (5) When soldering the ZNR lead wires, follow the recommended conditions and do not melt the solder and insulating materials constituting the ZNR.
- (6) When designing lead-wire-terminal land-hole of circuit board, please check actual ZNR by reference specification about center value of lead-wire terminal pitch.

	Soldering Method	Recommended Condition	Attention Item
Type D	Flow soldering	260 °C, within 10 seconds.	Type D is not Refl ow soldering object part.

- * 1 Soldering iron temperature should not exceed 400 °C and should not be applied for mor than 5 seconds.
- * 2 Profile be careful because there is a margin of error in the way of measuring.
- * 3 The temperature depend on the size and the package density of the substrate.
Therefore, confirm every kind of the substrate.

● Soldering temperature-time profile to recommend

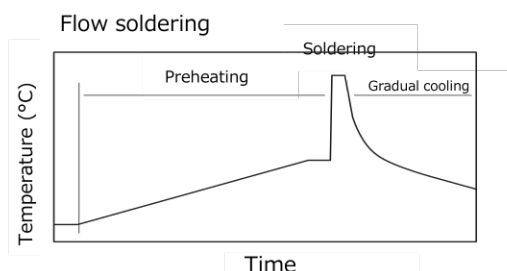

Preheating	The normal to 130 °C	max. 120 s
Soldering	max. 260 °C	max. 10 s
Gradual cooling	Gradual cooling	

4) Long-term storage

- (1) Do not store the ZNR under high temperature and high humidity. Store it indoor environment at a temperature up to 40 °C and at humidity below 75 %RH, and use it within two years.
Before using the ZNR that has been stored for a long period(two years or longer), confirm the solderability.
- (2) Avoid atmospheres full of corrosive gases (hydrogen sulfide, sulfurous acid, chlorine, ammonia, etc.).
- (3) Avoid direct sunlight and dew condensation.

5) Rated Voltage for UL or other safety certifications

Our ZNR define " Max. Allowable Voltage" and "Rated Voltage " to keep leakage current specification and others. If you getting certificate of safety approval about your equipment with our ZNR, please follow our "Rated Voltage".

6) Dropped product

Do not drop this product on the floor. If this product is dropped, it can be damaged mechanically or electrically. Avoid using the dropped product.

3. Notices

- 3.1 Our ZNR was designed and manufactured for standard applications such as general electronics devices, office equipment, information and communications equipment, measuring instruments, household appliances and audio-video equipment. For applications in which special quality and reliability are required, or if the failure or malfunction of the products may directly jeopardize life or cause threat of personal injury (such as for aircraft and aerospace equipment, traffic and transport equipment, combustion equipment, medical equipment, accident prevention and anti-theft devices, and safety equipment), please be sure to consult with our sales representative in advance and to exchange product specifications which conform to such applications. applications in which special quality and reliability are required, or if the failure or malfunction of the products may.
- 3.2 Note that we do not take any responsibility for faults and abnormalities resulting from the use not in conformity with the contents of entries in the delivery specification.
- 3.3 There is a possibility that the ZNR will unexpectedly cause smoke or ignite because of an abnormal rise of the circuit voltage and invasion of excessive surge. To prevent that accident from spreading over the equipment and not to expand the damage, use multiplex protection such as the adoption of flame-retardant materials for housing parts and structural parts.

4. Applicable laws and regulations , others

- 4.1 This product not been manufactured with any ozone depleting chemical controlled under the Montreal Protocol.
- 4.2 This product comply with RoHS(Restriction of the use of certain Hazardous Substance in electrical and electronic equipment) (DIRECTIVE 2011/65/EU and (EU)2015/863).
- 4.3 All the materials used in this part are registered material under the Law Concerning the Examination and Regulation of Manufacture, etc. of Chemical Substance.
- 4.4 If you need the notice by letter of “A preliminary judgement on the Laws of Japan foreign exchange and Foreign Trade Control”, be sure to let us know.
- 4.5 These products are not dangerous goods on the transportation as identified by UN(United nations) numbers or UN classification.

5. Others

- 5.1 As to the disposal of ZNR, check the method of disposal in each country or origin where the ZNR are incorporated in your products to be used.
- 5.2 The technical information in this specification provides example of our products’ typical operations and application circuit. We do not guarantee the non-infringement of third party’s intellectual property rights and we do not grant any license, right or interest in our intellectual property.