

4 Form C Flat type

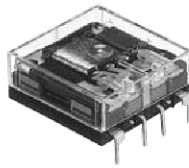

2 Form C Flat type

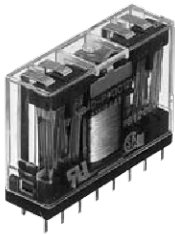

4 Form C Slim type
(PC board)

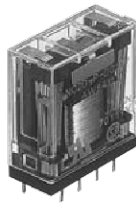

2 Form C Slim type
(PC board)

FEATURES

1. Compact, slim design

Use of high-performance flat electromagnetic design achieves 10.9 mm .429 inch profile, flat type thin package. Slim type, with width of 11.2 mm .441 inch, enables high-density mounting on PC boards.

2. High reliability

Provides stable contact pressure needed for card lift-off contact driver method. The use of Ac clad twin contacts provides stable contact resistance and ensures high contact reliability.

3. Compatible with all major safety standards

UL and CSA certified, and complies with Japanese Electrical Appliance and Material Control Law.

TYPICAL APPLICATIONS

1. Information processing and telecom equipment such as computers and terminal devices.
2. Gas hot air heating equipment and air conditioners.
3. Timer, temperature controller and other equipment that requires form factor reduction.
4. Transmission and measuring devices such as facsimile machines and electronic counting devices.
5. Control panels for industrial equipment such as machine tools, factory automation devices, and NC machines.

ORDERING INFORMATION

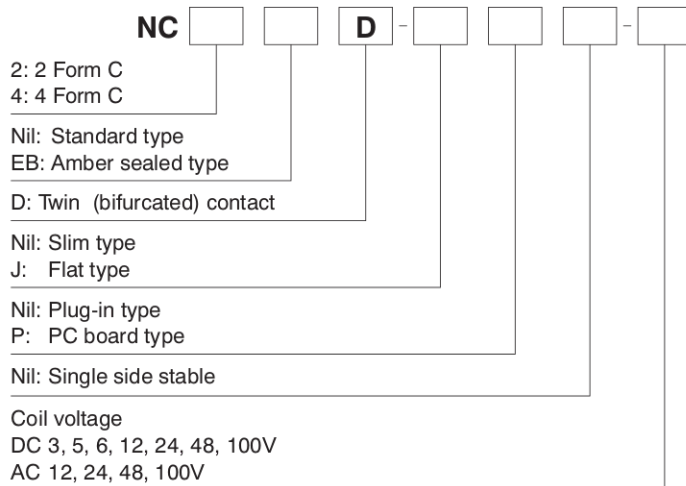

- Notes: 1. UL/CSA approved type is standard.
2. Amber sealed types are sealed and filled with inert gas (nitrogen gas).
Sealed construction with terminals, case and base sealed shut with sealing resin.

TYPES

<Standard type>

1. Flat type (PC board terminal)

Contact arrangement	Nominal coil voltage	Single side stable
		Part No.
2 Form C	12V AC	NC2D-JP-AC12V
	24V AC	NC2D-JP-AC24V
	48V AC	NC2D-JP-AC48V
	100V AC	NC2D-JP-AC100V
	3V DC	NC2D-JP-DC3V
	5V DC	NC2D-JP-DC5V
	6V DC	NC2D-JP-DC6V
	12V DC	NC2D-JP-DC12V
	24V DC	NC2D-JP-DC24V
	48V DC	NC2D-JP-DC48V
100V DC	NC2D-JP-DC100V	
4 Form C	12V AC	NC4D-JP-AC12V
	24V AC	NC4D-JP-AC24V
	48V AC	NC4D-JP-AC48V
	100V AC	NC4D-JP-AC100V
	3V DC	NC4D-JP-DC3V
	5V DC	NC4D-JP-DC5V
	6V DC	NC4D-JP-DC6V
	12V DC	NC4D-JP-DC12V
	24V DC	NC4D-JP-DC24V
	48V DC	NC4D-JP-DC48V
100V DC	NC4D-JP-DC100V	

Standard packing: Carton: 20 pcs.; Case: 200 pcs.

2. Slim type**1) Plug-in type**

Contact arrangement	Nominal coil voltage	Single side stable
		Part No.
2 Form C	12V AC	NC2D-AC12V
	24V AC	NC2D-AC24V
	48V AC	NC2D-AC48V
	100V AC	NC2D-AC100V
	3V DC	NC2D-DC3V
	5V DC	NC2D-DC5V
	6V DC	NC2D-DC6V
	12V DC	NC2D-DC12V
	24V DC	NC2D-DC24V
	48V DC	NC2D-DC48V
100V DC	NC2D-DC100V	
4 Form C	12V AC	NC4D-AC12V
	24V AC	NC4D-AC24V
	48V AC	NC4D-AC48V
	100V AC	NC4D-AC100V
	3V DC	NC4D-DC3V
	5V DC	NC4D-DC5V
	6V DC	NC4D-DC6V
	12V DC	NC4D-DC12V
	24V DC	NC4D-DC24V
	48V DC	NC4D-DC48V
100V DC	NC4D-DC100V	

Standard packing: Carton: 20 pcs.; Case: 200 pcs.

2) PC board type

Contact arrangement	Nominal coil voltage	Single side stable
		Part No.
2 Form C	12V AC	NC2D-P-AC12V
	24V AC	NC2D-P-AC24V
	48V AC	NC2D-P-AC48V
	100V AC	NC2D-P-AC100V
	3V DC	NC2D-P-DC3V
	5V DC	NC2D-P-DC5V
	6V DC	NC2D-P-DC6V
	12V DC	NC2D-P-DC12V
	24V DC	NC2D-P-DC24V
	48V DC	NC2D-P-DC48V
100V DC	NC2D-P-DC100V	
4 Form C	12V AC	NC4D-P-AC12V
	24V AC	NC4D-P-AC24V
	48V AC	NC4D-P-AC48V
	100V AC	NC4D-P-AC100V
	3V DC	NC4D-P-DC3V
	5V DC	NC4D-P-DC5V
	6V DC	NC4D-P-DC6V
	12V DC	NC4D-P-DC12V
	24V DC	NC4D-P-DC24V
	48V DC	NC4D-P-DC48V
100V DC	NC4D-P-DC100V	

Standard packing: Carton: 20 pcs.; Case: 200 pcs.

<Amber type>

1. Flat type (PC board terminal)

Contact arrangement	Nominal coil voltage	Single side stable
		Part No.
2 Form C	3V DC	NC2EBD-JP-DC3V
	5V DC	NC2EBD-JP-DC5V
	6V DC	NC2EBD-JP-DC6V
	12V DC	NC2EBD-JP-DC12V
	24V DC	NC2EBD-JP-DC24V
	48V DC	NC2EBD-JP-DC48V
	100V DC	NC2EBD-JP-DC100V
4 Form C	3V DC	NC4EBD-JP-DC3V
	5V DC	NC4EBD-JP-DC5V
	6V DC	NC4EBD-JP-DC6V
	12V DC	NC4EBD-JP-DC12V
	24V DC	NC4EBD-JP-DC24V
	48V DC	NC4EBD-JP-DC48V
100V DC	NC4EBD-JP-DC100V	

Standard packing: Carton: 20 pcs.; Case: 200 pcs.

2. Slim type

1) Plug-in type

Contact arrangement	Nominal coil voltage	Single side stable
		Part No.
2 Form C	3V DC	NC2EBD-DC3V
	5V DC	NC2EBD-DC5V
	6V DC	NC2EBD-DC6V
	12V DC	NC2EBD-DC12V
	24V DC	NC2EBD-DC24V
	48V DC	NC2EBD-DC48V
	100V DC	NC2EBD-DC100V
4 Form C	3V DC	NC4EBD-DC3V
	5V DC	NC4EBD-DC5V
	6V DC	NC4EBD-DC6V
	12V DC	NC4EBD-DC12V
	24V DC	NC4EBD-DC24V
	48V DC	NC4EBD-DC48V
100V DC	NC4EBD-DC100V	

Standard packing: Carton: 20 pcs.; Case: 200 pcs.

2) PC board type

Contact arrangement	Nominal coil voltage	Single side stable
		Part No.
2 Form C	3V DC	NC2EBD-P-DC3V
	5V DC	NC2EBD-P-DC5V
	6V DC	NC2EBD-P-DC6V
	12V DC	NC2EBD-P-DC12V
	24V DC	NC2EBD-P-DC24V
	48V DC	NC2EBD-P-DC48V
	100V DC	NC2EBD-P-DC100V
4 Form C	3V DC	NC4EBD-P-DC3V
	5V DC	NC4EBD-P-DC5V
	6V DC	NC4EBD-P-DC6V
	12V DC	NC4EBD-P-DC12V
	24V DC	NC4EBD-P-DC24V
	48V DC	NC4EBD-P-DC48V
	100V DC	NC4EBD-P-DC100V

Standard packing: Carton: 20 pcs.; Case: 200 pcs.

RATING

1. Coil data

1) Single side stable type (AC)

No. of poles	Nominal coil voltage	Pick-up voltage (at 20°C 68°F)	Drop-out voltage (at 20°C 68°F)	Nominal operating current [$\pm 10\%$] (at 20°C 68°F)	Coil inductance		Nominal operating power	Max. allowable voltage (at 50°C 122°F)
					N.C. condition	N.O. condition		
2 Form C	12V AC	80%V or less of nominal voltage (Initial)	10%V or more of nominal voltage (Initial)	41.5mA	—	—	0.50VA	110%V of nominal voltage
	24V AC			22.5mA	—	—	0.54VA	
	48V AC			14.0mA	—	—	0.67VA	
	100V AC			10.5mA	—	—	1.05VA	
4 Form C	12V AC	80%V or less of nominal voltage (Initial)	10%V or more of nominal voltage (Initial)	92mA	—	—	1.10VA	110%V of nominal voltage
	24V AC			45mA	—	—	1.08VA	
	48V AC			22.5mA	—	—	1.08VA	
	100V AC			13.0mA	—	—	1.30VA	

2) Single side stable (DC)

No. of poles	Nominal coil voltage	Pick-up voltage (at 20°C 68°F)	Drop-out voltage (at 20°C 68°F)	Nominal operating current [$\pm 10\%$] (at 20°C 68°F)	Coil resistance [$\pm 10\%$] (at 20°C 68°F)	Nominal operating power	Coil inductance		Max. allowable voltage (at 50°C 122°F)*
							N.C. condition	N.O. condition	
2 Form C	3V DC	80%V or less of nominal voltage (Initial)	10%V or more of nominal voltage (Initial)	120mA	25 Ω	360mW	24.2mH	30.0mH	135%V of nominal voltage
	5V DC			72mA	69.4 Ω	360mW	69.5mH	86.0mH	
	6V DC			60mA	100 Ω	360mW	99.4mH	123mH	
	12V DC			30mA	400 Ω	360mW	388mH	480mH	
	24V DC			15mA	1,600 Ω	360mW	1,590mH	1,970mH	
	48V DC			7.5mA	6,400 Ω	360mW	6,270mH	7,680mH	
	100V DC			7.4mA	13,500 Ω	740mW	9,470mH	11,700mH	110%V of nominal voltage
4 Form C	3V DC	80%V or less of nominal voltage (Initial)	10%V or more of nominal voltage (Initial)	240mA	12.5 Ω	720mW	12.8mH	15.8mH	110%V of nominal voltage
	5V DC			144mA	34.7 Ω	720mW	34.3mH	42.4mH	
	6V DC			120mA	50 Ω	720mW	50.7mH	62.7mH	
	12V DC			60mA	200 Ω	720mW	203mH	252mH	
	24V DC			30mA	800 Ω	720mW	812mH	1,000mH	
	48V DC			15mA	3,200 Ω	720mW	2,820mH	3,480mH	
	100V DC			7.4mA	13,500 Ω	740mW	14,100mH	17,400mH	

* At 20°C 68°F (Amber type)

2. Specifications

Characteristics	Item	Specifications					
		DC		AC	DC		
		Single side stable		Single side stable	Single side stable		
Contact	Arrangement	2 Form C			4 Form C		
	Initial contact resistance, max.	Max. 50 mΩ (By voltage drop 6 V DC 1A)				Max. 50 mΩ (By voltage drop 6 V DC 1A)	
	Contact material	Au-clad AgNi type			Au-clad AgNi type		
Rating	Nominal switching capacity (resistive load)	Standard: 5A 250V AC, 5A 30V DC Amber: 3A 250V AC, 5A 30V DC			Standard: 4A 250V AC, 5A 30V DC Amber: 2A 250V AC, 5A 30V DC		
	Max. switching power (resistive load)	Standard: 1,250VA, 150W Amber: 750VA, 150W			Standard: 1,000VA, 150W Amber: 500VA, 150W		
	Max. switching voltage	250 V AC					
	Max. switching current	Standard: 5A Amber: 3A (AC), 5A (DC)			Standard: 4A Amber: 2A (AC), 5A (DC)		
	Nominal operating power	360mW (740mW: 100V DC)		0.50VA to 1.05VA	720mW*2		1.08VA to 1.30VA
	Min. switching capacity (Reference value)*1	100μA 1V DC				100μA 1VDC	
	Electrical characteristics	Insulation resistance (Initial)	Min. 100MΩ (at 500V DC) Measurement at same location as "Initial breakdown voltage" section.			Min. 100MΩ (at 500V DC) Measurement at same location as "Initial breakdown voltage" section.	
Breakdown voltage (Initial)		Between open contacts	1,000 Vrms for 1min. (Detection current: 10mA.)			1,000 Vrms for 1min. (Detection current: 10mA.)	
		Between contact sets	1,000 Vrms for 1min. (Detection current: 10mA.)			1,000 Vrms for 1min. (Detection current: 10mA.)	
		Between contact and coil	2,000 Vrms for 1min. (Detection current: 10mA.)			2,000 Vrms for 1min. (Detection current: 10mA.)	
Temperature rise		Max. 65°C [Max. 85°C (100V AC)] (By resistive method, nominal voltage)					
Operate time (at 20°C 68°F)		Max. 20ms		Max. 30ms*3	Max. 20ms		Max. 30ms*3
Release time (at 20°C 68°F)		Max. 10ms		Max. 40ms*3	Max. 10ms		Max. 40ms*3
Mechanical characteristics	Shock resistance	Functional	Min. 98 m/s ² (Half-wave pulse of sine wave: 11 ms; detection time: 10μs.)				
		Destructive	Min. 980 m/s ² (Half-wave pulse of sine wave: 6 ms.)				
	Vibration resistance	Functional	10 to 55 Hz at double amplitude of 1 mm (Detection time: 10μs.)				
Destructive		10 to 55 Hz at double amplitude of 2 mm					
Expected life	Mechanical	Min. 5×10 ⁷		Min. 10 ⁷	Min. 5×10 ⁷		Min. 10 ⁷
	Electrical (resistive load)	Standard: Min. 10 ⁵ (5A 250V AC), Min. 5×10 ⁵ (5A 30V DC) Amber: Min. 10 ⁵ (3A 250V AC), Min. 5×10 ⁵ (5A 30V DC)			Standard: Min. 10 ⁵ (4A 250V AC), Min. 5×10 ⁵ (5A 30V DC) Amber: Min. 10 ⁵ (2A 250V AC), Min. 5×10 ⁵ (5A 30V DC)		
Conditions	Conditions for operation, transport and storage*4 (Not freezing and condensing at low temperature)	-40°C to +70°C -40°F to +158°F (Max.48V DC), -40°C to +55°C -40°F to +131°F (100V DC)		-40°C to +60°C -40°F to +140°F*5	-40°C to +55°C -40°F to +131°F		-40°C to +40°C -40°F to +104°F
		Max. Operating speed		50 cps			
	Unit weight	16 g .56 oz			18 g .63 oz		

Notes: *

*1 This value can change due to the switching frequency, environmental conditions, and desired reliability level, therefore it is recommended to check this with the actual load.

*2. 100V DC: 740mW

*3. For the AC type, the operate and release time differs depending on the phase of the input and cutoff times.

*4. Refer to "6. Usage, Storage and Transport Conditions" in [AMBIENT ENVIRONMENT section in Relay Technical Information](#).

*5. 100V DC: -40°C to +40°C -40°F to +104°F

REFERENCE DATA (Standard type)

1.-(1) Life curve
(AC/DC load 2 Form C, 4 Form C)

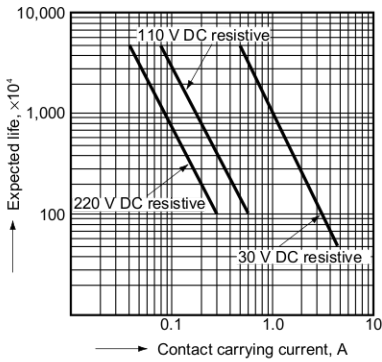

1.-(2) Life curve (AC/DC load 2 Form C)

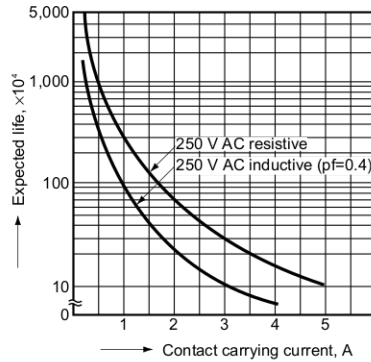

1.-(3) Life curve (AC/DC load 4 Form C)

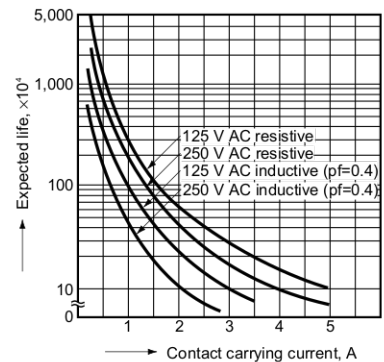

2. Temperature rise characteristics
(single side stable)

Measured portion: Inside the coil

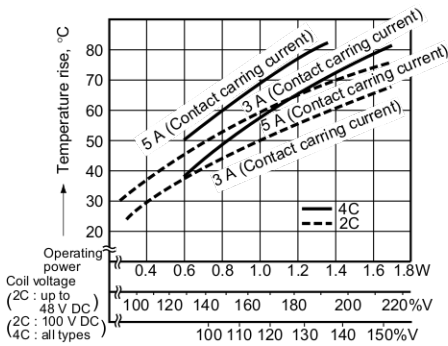

3. Operate time (single side stable)

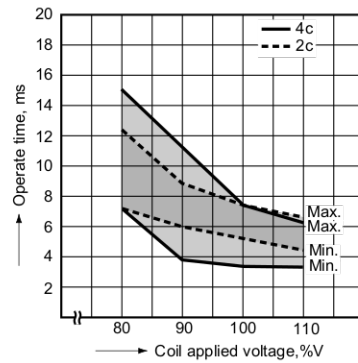

4. Release time (single side stable)

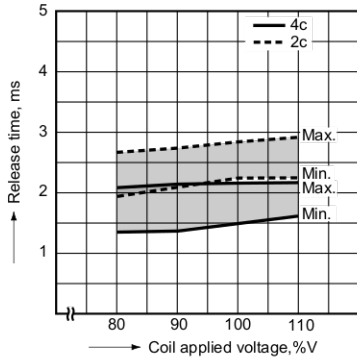

5.-(1) Rate of change of pick-up and drop-out voltage
(2 Form C single side stable)

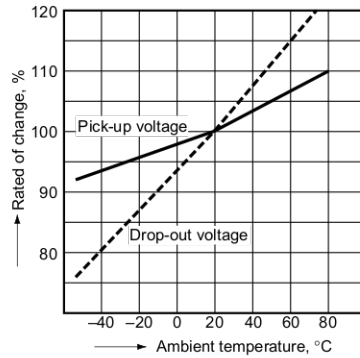

5.-(2) Rate of change of pick-up and drop-out voltage
(4 Form C single side stable)

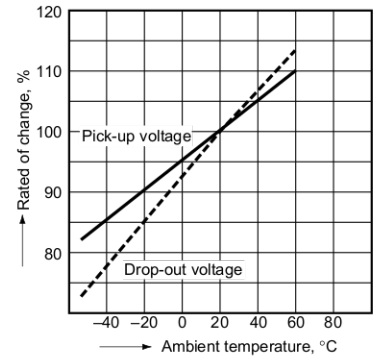

6.-(1) Ambient temperature vs Max. continuous voltage

Tested sample:
NC2D-P-DC24 V (2 Form C slim single side stable)

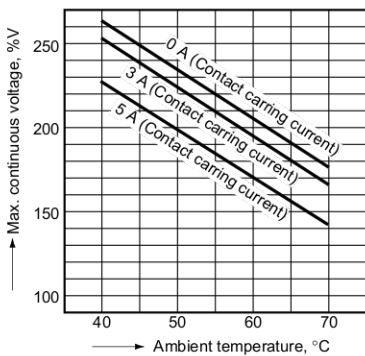

6.-(2) Ambient temperature vs Max. continuous voltage

Tested sample:
NC2D-P-DC110 V (2 Form C slim single side stable),
NC4D-P-DC24 V (4 Form C slim single side stable)

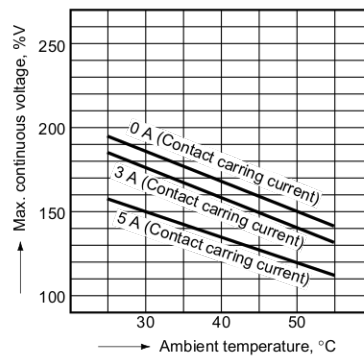

DIMENSIONS (Unit: mm inch)

<Standard type>

Flat type
2 Form C

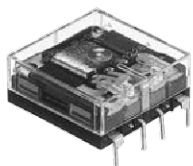

External dimensions

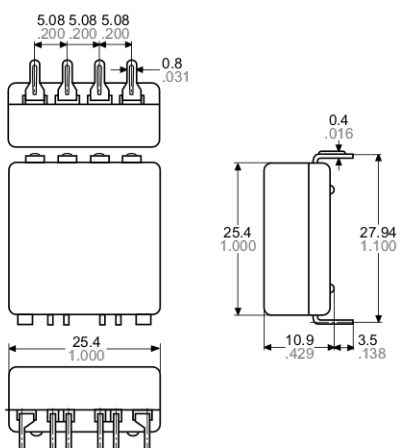

Schematic (Top view)
Single side stable

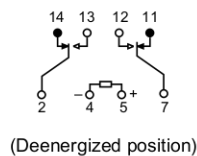

PC board pattern (Bottom view)
Single side stable

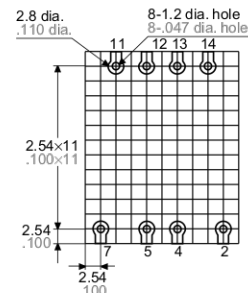

Note: Single side stable types do not have terminals 3 and 6.

Flat type
4 Form C

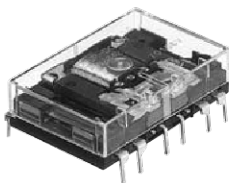

External dimensions

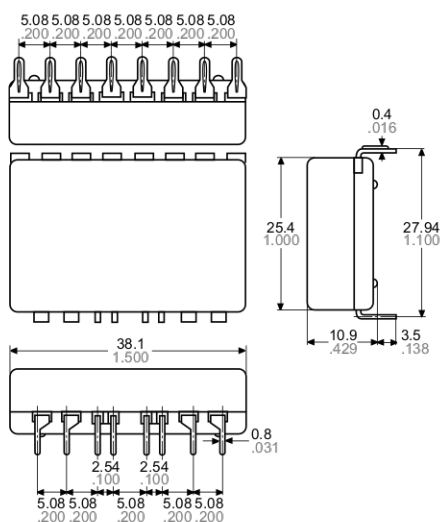

Schematic (Top view)
Single side stable

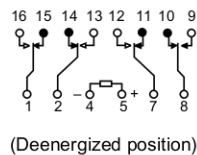

PC board pattern (Bottom view)
Single side stable

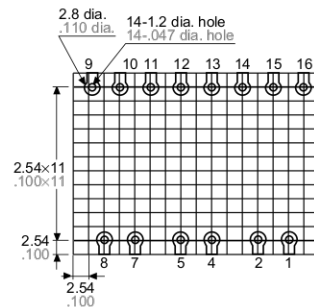

Note: Single side stable types do not have terminals 3 and 6.

NC

Slim type
Plug-in type
2 Form C



External dimensions

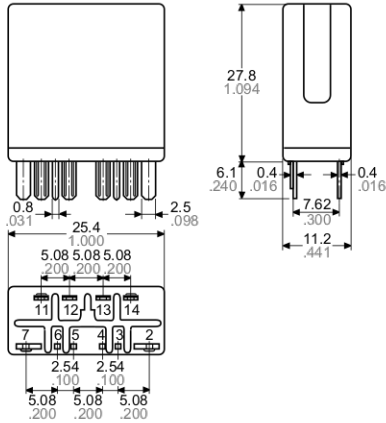

Schematic (Bottom view)

Single side stable

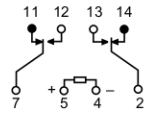

(Deenergized position)

Note: Single side stable types do not have terminals 3 and 6.

Slim type
Plug-in type
4 Form C

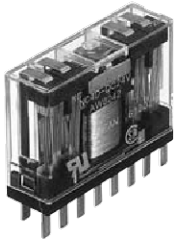

External dimensions

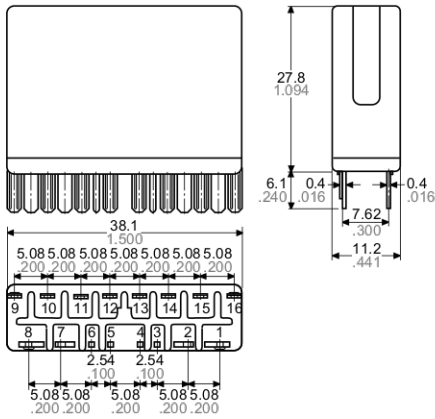

Schematic (Bottom view)

Single side stable

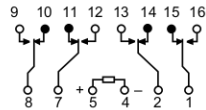

(Deenergized position)

Note: Single side stable types do not have terminals 3 and 6.

Slim type
PC board type
2 Form C

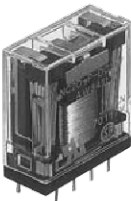

External dimensions

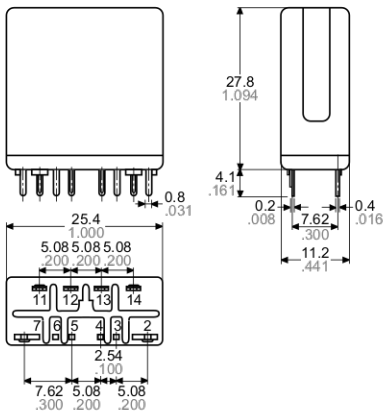

(Dowel height: 0.4 .016)

Schematic (Bottom view)

Single side stable

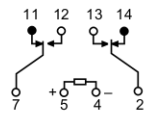

(Deenergized position)

PC board pattern (Bottom view)

Single side stable

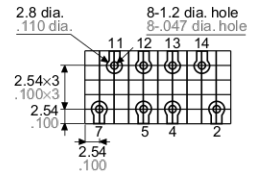

Note: Single side stable types do not have terminals 3 and 6.

Slim type
PC board type
4 Form C

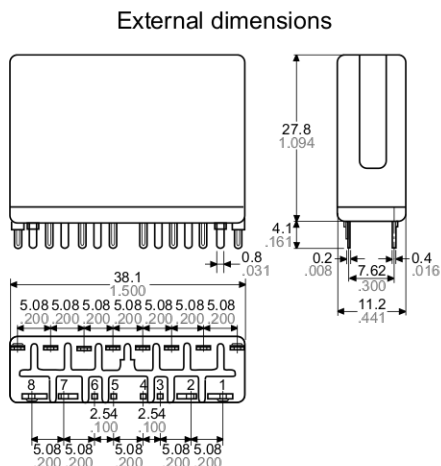
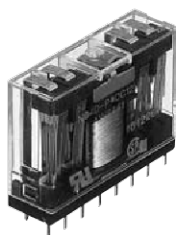

(Dowel height: 0.4 .016)

Schematic (Bottom view)
Single side stable

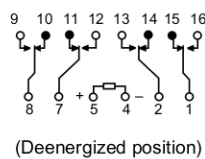

PC board pattern (Bottom view)
Single side stable

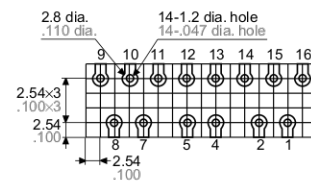

Note: Single side stable types do not have terminals 3 and 6.

<Amber sealed type>

Flat type
2 Form C

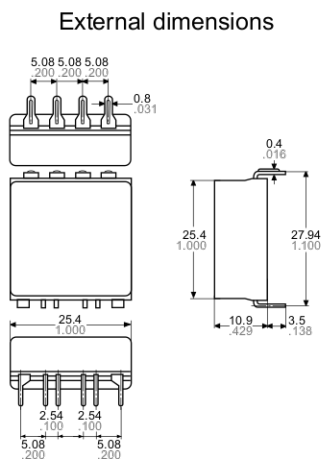

Schematic (Top view)

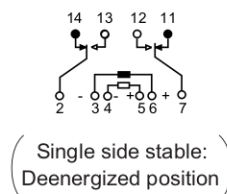

PC board pattern (Bottom view)

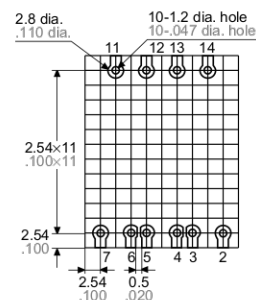

Note: Single side stable types do not have terminals 3 and 6.

Flat type
4 Form C

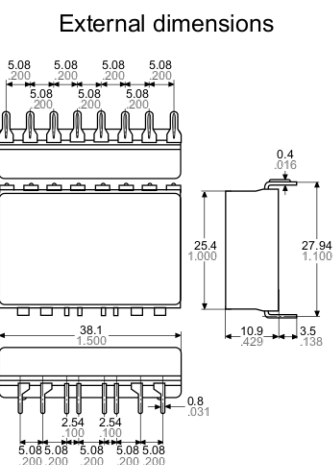
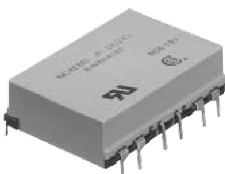

Schematic (Top view)

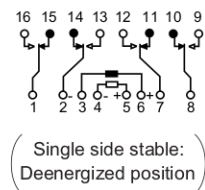

PC board pattern (Bottom view)

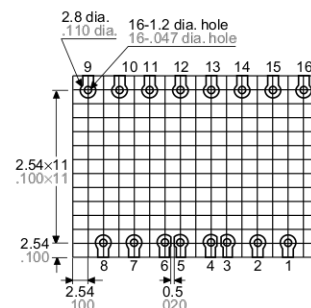

Note: Single side stable types do not have terminals 3 and 6.

NC

Slim type
Plug-in type
2 Form C



External dimensions

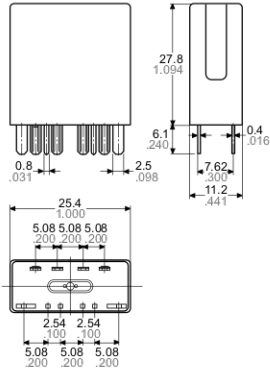

Schematic (Bottom view)

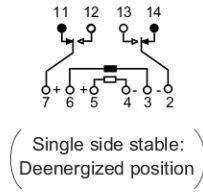

Note: Single side stable types do not have terminals 3 and 6.

Slim type
Plug-in type
4 Form C



External dimensions

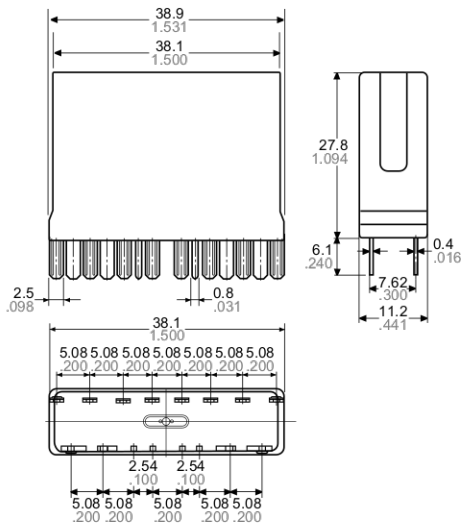

Schematic (Bottom view)

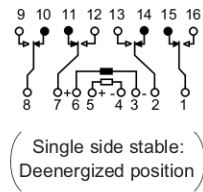

Note: Single side stable types do not have terminals 3 and 6.

Slim type
PC board type
2 Form C



External dimensions

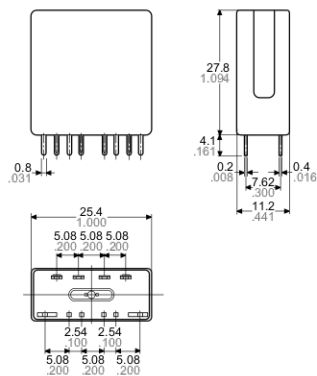

Schematic (Bottom view)

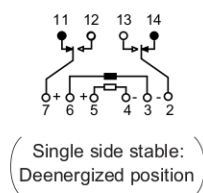

PC board pattern (Bottom view)

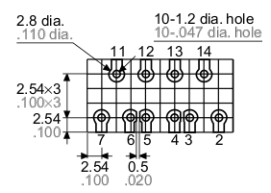

Note: Single side stable types do not have terminals 3 and 6.

Slim type
PC board type
4 Form C

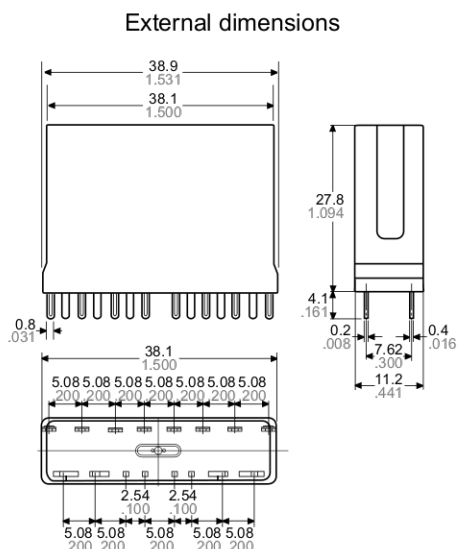

Schematic (Bottom view)

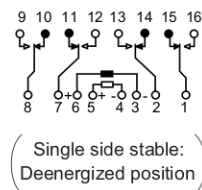

PC board pattern (Bottom view)

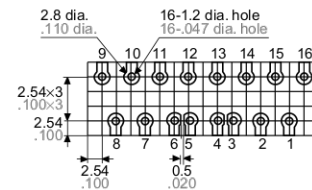

Note: Single side stable types do not have terminals 3 and 6.

NOTES

1. Because the NC relay is polarized, the positive “+” and negative “-” connections to the coil should be done as indicated on the wiring diagram. If connected incorrectly, it may malfunction or fail to operate.
2. As a 2 coil latching type, under the stipulations of the Japanese Electrical Appliance and Material Control Law, because the terminals of NC relay coils have an insulation distance of more than 1.5 mm, NC relays can be used in power supply operating circuits of up to 100 V. When used in contact circuits, 200 V is the maximum voltage.
3. To maintain insulation between coils of 2 coil latching series, terminals ⑤ and ⑥ for flat series, and terminals ③ and ④ for vertical series should be connected to provide common return.

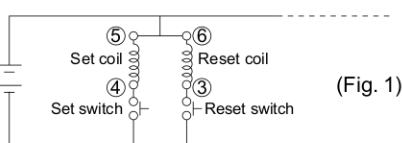
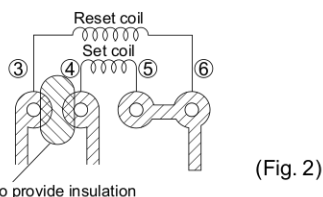
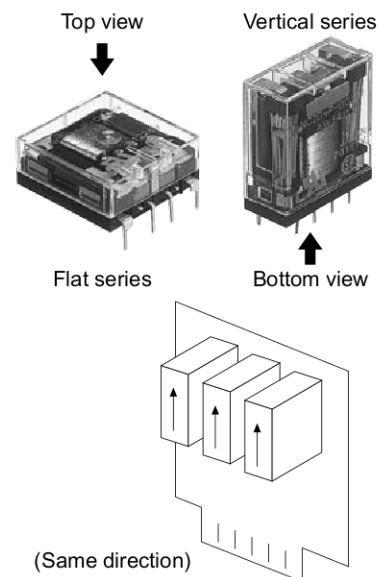

Figure 1 shows wiring that complies with Japanese Electrical Appliance and Material Control Law stipulations for power supply circuits. At the copper traces on PC boards, between terminals ③ and ④, as shown in Figure 2, apply epoxy resin (to thickness of more than 3 mm) or similarly adhesive to provide insulation.



4. 2 coil latching series 4 Form C are for intermittent operation only. Power should be applied to coils continuously for no more than two minutes. See page 30 for general cautions to be observed regarding latching relays.
5. While NC relays can be used with any transmission-wave current to their operation, due to slight weakening of the force of magnetic attraction, decreased resistance to vibration and shock should be taken into account.
6. The current that energizes the coil in an NC relay is AC type. Because the AC sine waveform is distorted, when testing, it is essential to use a measuring device that can properly characterize the distorted waveform. The operating power of the coil in the 100 V AC 4 Form C type is relatively higher than other NC types of AC relay and consequently, the total current applied through all the contacts should be kept below 10 A.
7. The AC type NC relay has a special magnetic design. As a result, once the a-side contacts have switched, the b-side contacts may once again go into a temporary ON state depending on the coil inrush phase. To ensure that this phenomenon does not occur, it is necessary to carry out sufficient practical testing with relays installed in actual devices.

8. When designing top and bottom view schematic diagrams, note that:
 - 1) “Top view” wiring diagram is indicated for the flat series because terminals can be seen from above.
 - 2) “Bottom view” schematic diagram is indicated for the vertical series because terminals cannot be seen from above.



9. Cautions for close proximity mounting
When using slim series in close proximity, mount all relays facing the same direction. Different mounting directions may cause change in the relay characteristics because NC relays are polarized.

For Cautions for Use, see [Relay Technical Information](#).

FEATURES

• **Socket**

1) The vertical (slim) type with solder terminals has a retainer, which enables snap-in fixing on chassis, panels, and similar locations. Because the sockets for both solder terminals and PC boards firmly fix the relay at the time of insertion, once snapped in, spring clips are unnecessary.

2) For the flat type, pull up the hinged clasps in the direction of the arrows shown in the drawing after inserting the relay. Spring clips are unnecessary.

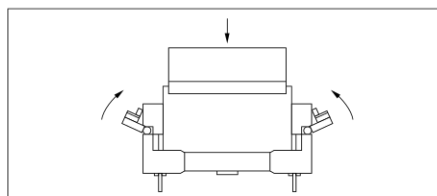

NC2 Flat type socket



NC4 Flat type socket



NC2 Slim type socket



NC4 Slim type socket



NC2 DIN terminal socket

TYPES

	Product name	Terminals	Part No.
Flat type socket	NC2-flat type PC board socket	P/C board	NC2-JPS
	NC2-flat, 2 coil latching type PC board socket	P/C board	NC2-JPL2S
	NC4-flat type PC board socket	P/C board	NC4-JPS
	NC4-flat, 2 coil latching type PC board socket	P/C board	NC4-JPL2S
Slim type terminal socket	NC2-DIN terminal socket	DIN rail	NC2-SFD
Slim type socket	NC2-slim type socket	Solder	NC2-SS
	NC2-slim, 2 coil latching type socket	Solder	NC2-LS2
	NC2-slim type PC board socket	P/C board	NC2-PS
	NC2-slim, 2 coil latching type PC board socket	P/C board	NC2-L2P
	NC2-slim type wrapping socket	Lead wire	NC2-WS
	NC2-slim, 2 coil latching type wrapping socket	Lead wire	NC2-LSWS
	NC4-slim type socket	Solder	NC4-SS
	NC4-slim, 2 coil latching type socket	Solder	NC4-LS2
	NC4-slim type PC board socket	P/C board	NC4-PS
	NC4-slim, 2 coil latching type PC board socket	P/C board	NC4-L2P
	NC4-slim type wrapping socket	Lead wire	NC4-WS
	NC4-slim, 2 coil latching type wrapping socket	Lead wire	NC4-LSWS

SPECIFICATIONS (common)

Item	Specifications
Max. continuous current	Slim type: 5A 250V AC, Flat type: 5A 250V AC
Initial breakdown voltage	2,000 V AC (Except for coil to coil of L2 type: 1,500 V AC)
Initial insulation resistance	Min. 100MΩ (at 500V DC megger)
Heat resistance	150°C 302°F for 1 hour

Note: Do not insert or remove relays while in the energized condition.

DIMENSIONS (Unit: mm inch)

Flat type socket

for PC board

NC2-JPS
NC2-JPL2S



External dimensions

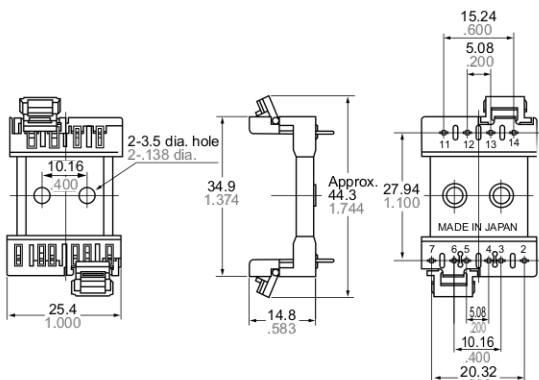

Terminal portion

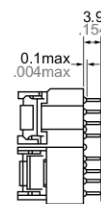

PC board pattern

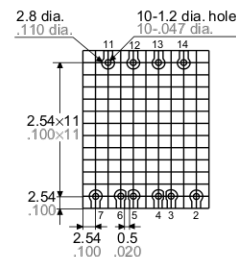

Note: Terminals 3 and 6 excluded for NC2-JPS.

Flat type socket

for PC board

NC4-JPS
NC4-JPL2S



External dimensions

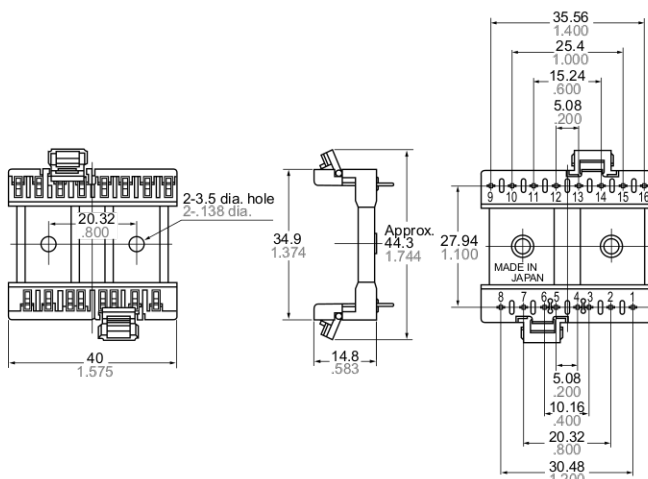

Terminal portion

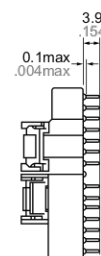

PC board pattern

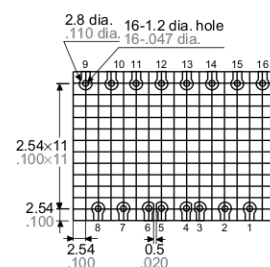

Note: Terminals 3 and 6 excluded for NC4-JPS.

Slim type DIN terminal socket

NC2-SFD

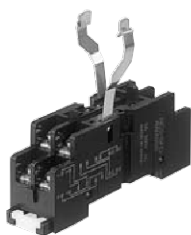

External dimensions

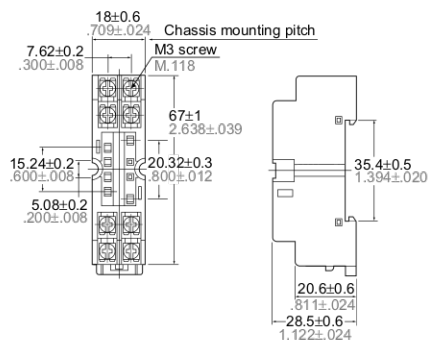

Mounting hole diagram

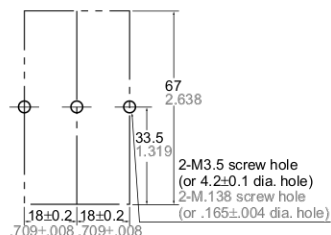

Schematic

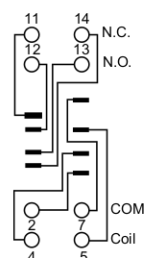

(Retaining springs are included with the DIN terminal socket.)

*To prevent damage or distortion, when tightening fixing screws, the optimum torque range should be 0.49 to 0.69 N-m, (5 to 7 kgf-cm).

NC

Slim type socket for solder terminal

NC2-SS
NC2-L2S

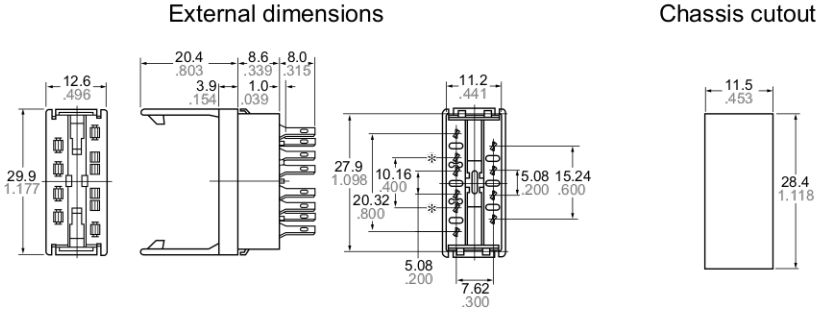
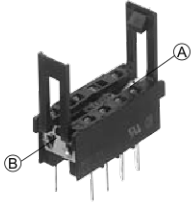

- Notes: 1. Suitable chassis thickness is 1.0 to 2.0 mm .039 to .079 inch.
2. Once the socket is inserted from above into the mounting holes, the relay will snap in to clips rising from either side at (A) and (B) by pushing.

Note: NC2-SS is as shown in the diagram above except that terminals marked with "*" are not present.

Slim type socket for solder terminal

NC4-SS
NC4-L2S

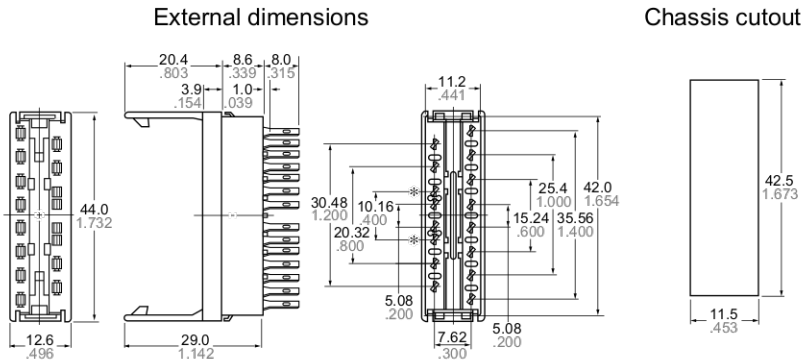
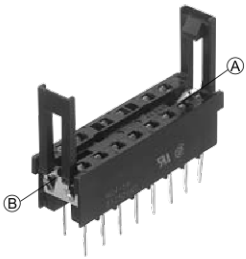

- Notes: 1. Suitable chassis thickness is 1.0 to 2.0 mm .039 to .079 inch.
2. Once the socket is inserted from above into the mounting holes, the relay will snap in to clips rising from either side at (A) and (B) by pushing.

Note: NC4-SS is as shown in the diagram above except that terminals marked with "*" are not present.

Slim type socket for PC board

NC2-PS
NC2-L2P

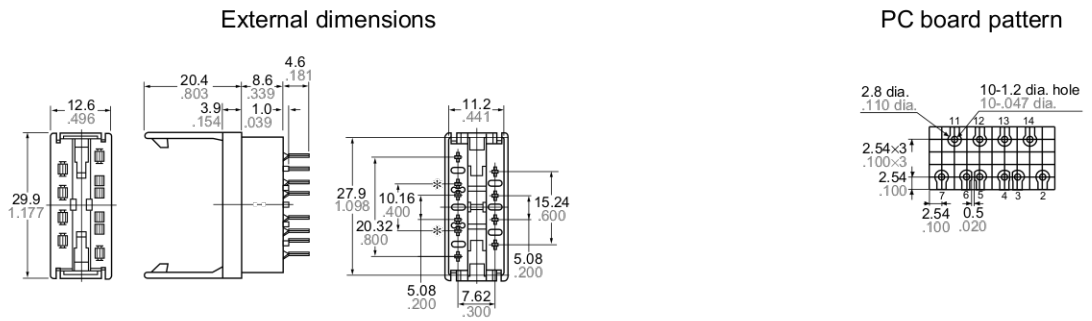

Note: NC2-PS is as shown in the diagram at left except that terminals marked with "*" are not present.

Slim type socket for PC board

NC4-PS
NC4-L2P

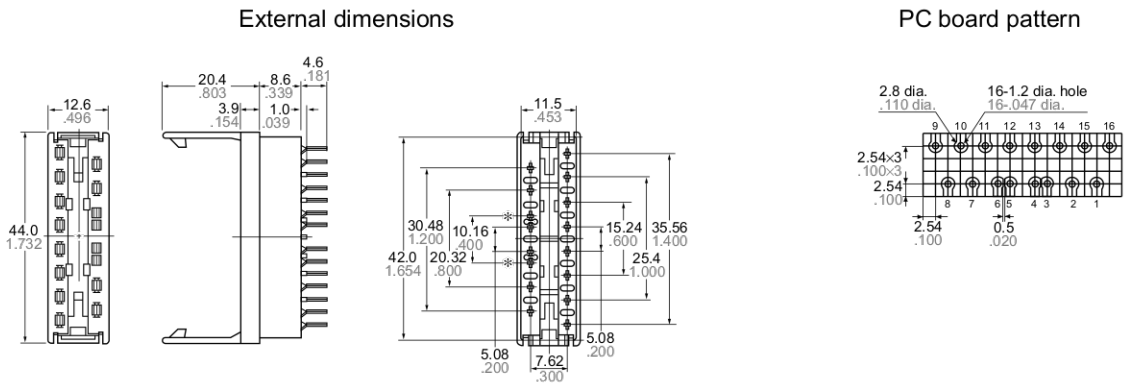

Note: NC4-PS is as shown in the diagram at left except that terminals marked with "*" are not present.

Vertical (Slim) type wrapping socket

NC2-WS
NC2-L2WS



External dimensions

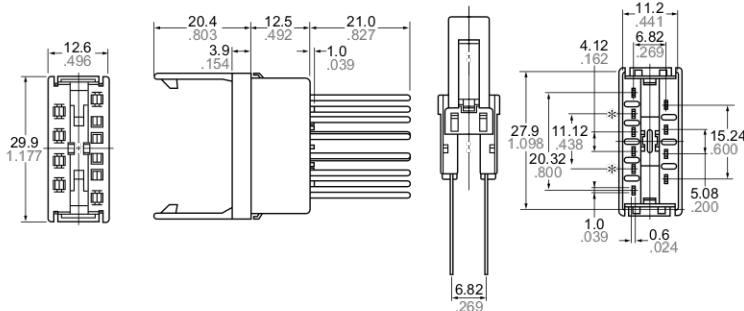

Terminal cross section

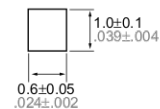

Chassis cutout

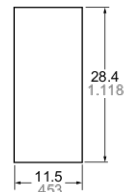

Note: NC2-WS is as shown in the diagram above except that terminals marked with " * " are not present.

Vertical (Slim) type wrapping socket

NC4-WS
NC4-L2WS



External dimensions

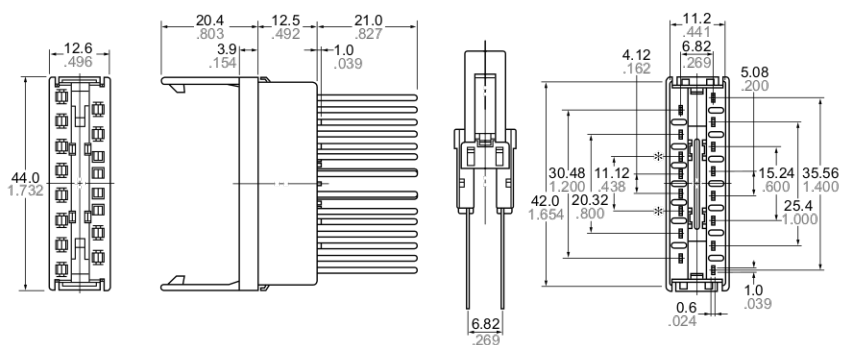

Chassis cutout

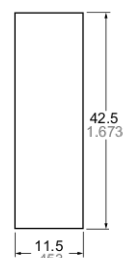

Note: NC4-WS is as shown in the diagram above except that terminals marked with " * " are not present.

NOTES

1. Soldering should be done quickly to avoid damaging the thermoplastic body.
2. For solder terminal types, connect terminals as shown in the diagram at

