

## Product Specifications

**Model Name : Laser Type PM Sensor**  
**Model No. : SN-GCJA5**  
**Issue Number : JA5-SSP-E2.0**  
**Company : Panasonic Photo & Lighting Co., Ltd.**  
**1-1 Saiwai-cho, Takatsuki-city, Osaka, Japan**

Customer Approval

Panasonic Photo & Lighting Co., Ltd.		
Approved	Checked	Prepared
Date:	Date:	Date:

【Revision records】

Term	Date	Contents	Approved	Checked
0.0	2018.7.1	Preliminary issued		Miyashita
0.1	2018.7.6	Add "Wiring Reference", Correct typos		Miyashita
	2018.7.19	TYPO on page4 corrected		Miyashita
	2018.9.25	TYPO on page8 corrected		Miyashita
0.2	2018.11.16	TBD items fixed, Change lot# rule, etc.		Sumisaki
0.3	2019.1.18	"Indicatable range" revised		Miyashita
1.0	2019.1.18	Officially Issued	Maeda	Sumisaki
2.0	2021.2.1	Add handling instruction and special notice	Maeda	Sumisaki

**■ Outline**

The sensor detects “PM (particle matters) in the air” by optical method.

This sensor uses LD (laser diode) as light-emitting device and PD (photo diode) as light-receiving device.

The LD inside the sensor emits light to the air in a detection area. The PD inside the sensor detects scattering light which correlated to the actual floating particles in the air. A Microcomputer (MCU) inside the sensor analyzes the wave profile from PD by optimistic algorithm, then output a converted mass-density ( $\mu\text{g}/\text{m}^3$ ) through I<sup>2</sup>C & UART interface.

**■ Main Features**

- Smaller size
- High accuracy ( $\pm 10\%$ , from low to high concentrations)
- High sensitivity & quick response
- Maintain performance by unique Auto Calibration Function
- Minimize dust accumulation by optimized air pathway structure and it makes possible to avoid “tracking” for electrical safety

**■ Environmental Responsiveness**

- This product complies with RoHS directive.

**■ Usage Application**

- To detect the floating particle in the air (PM2.5, PM10 & PM1, cigarette smoke, house dust, etc.)  
Ex: air purifier, fan, and air conditioner

**■ Dimensions**

37 x 37 x 12 (thickness) [mm]

**■ Weight**

Approx. 13 [g]

■ Operating Characteristics

Category	Characteristics	Note
Operating voltage	DC5V +/-10%	
Consumption current	Below 100mA	
Operating temperature	-10 ~ 60°C, under 95%RH	no dew condensation
Storage temperature	-40 ~ 70°C, under 95%RH	no dew condensation
Minimum detectable particle	0.3µm	
Indicatable range:	0µg/m <sup>3</sup> – 2,000µg/m <sup>3</sup> (UART) 0µg/m <sup>3</sup> – X,XXXµg/m <sup>3</sup> (I <sup>2</sup> C)	
Maximum consistency error	±10%	35µg/m <sup>3</sup> <、 <1,000µg/m <sup>3</sup>
Response time	1 sec	
Time to first reading	8 sec	
Initial stability time	Approx. 28 sec after power on	8 sec for initialization 20 sec for average processing
Output method	Digital signal output · I <sup>2</sup> C & UART (TTL)	Refer to the Communication Specifications

※ There is no noise (sound) standard, please check the performance in actual use condition.

■ Block Diagram

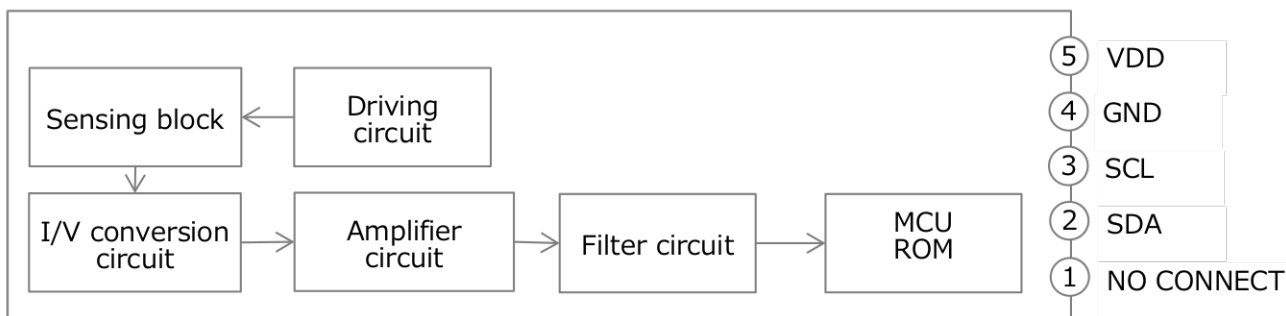

Connector : SM05B-GHS-TB(LF)(SN) (J.S.T. Mfg. Co., Ltd.)

■ Terminal Function

Terminal	Symbol	I/O	Function
1	TX	Output	UART TX terminal : 3.3V
2	SDA	Input / Output	I <sup>2</sup> C bus serial data input-output terminal : 3.3V *
3	SCL	Input	I <sup>2</sup> C bus serial clock input terminal : 3.3V *
4	GND	-	Grand terminal : 0V
5	VDD	-	Power supply terminal : 5V

\* SCL terminal and SDA terminal have pull-up resistor by 3.3V.

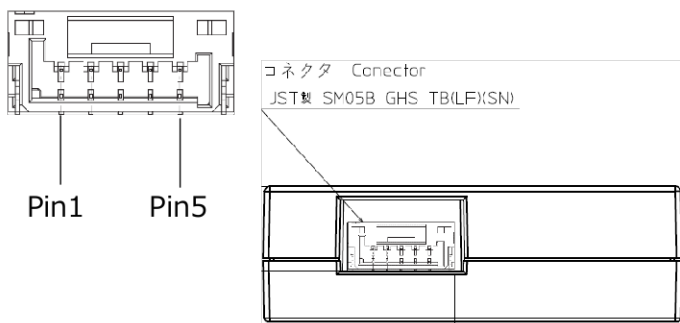

■ Wiring Reference

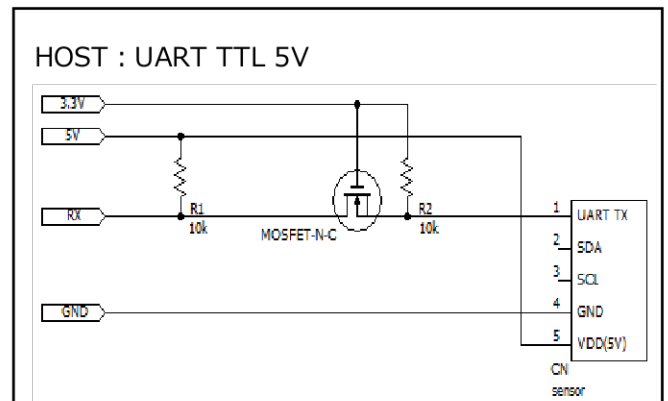
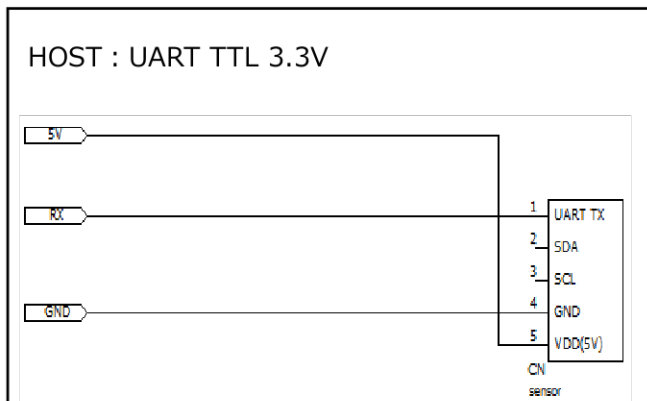
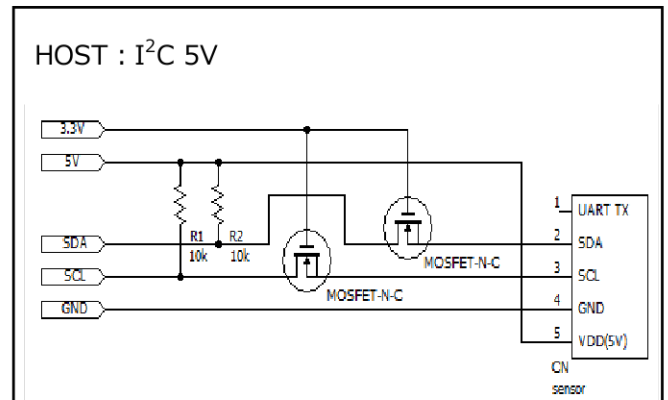
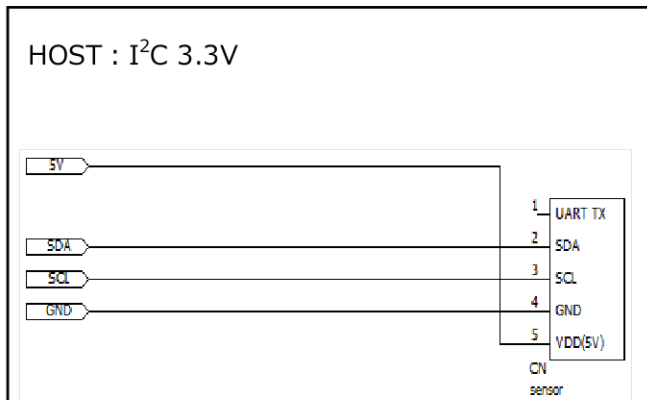

■ Sensor Characteristics

Measurement accuracy

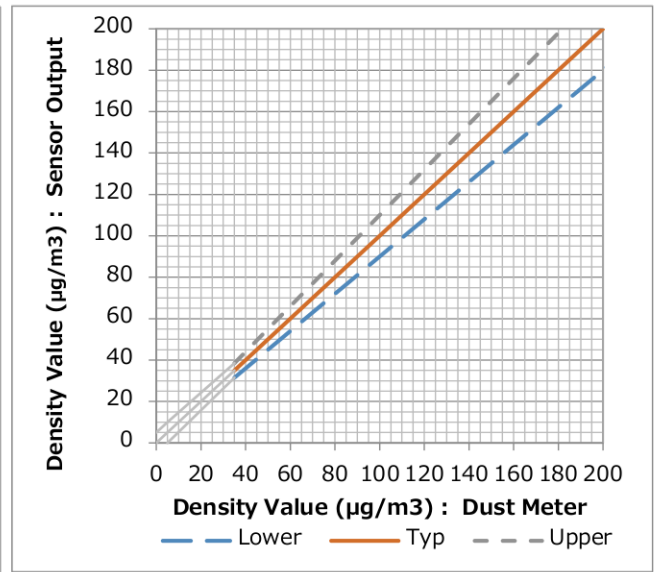
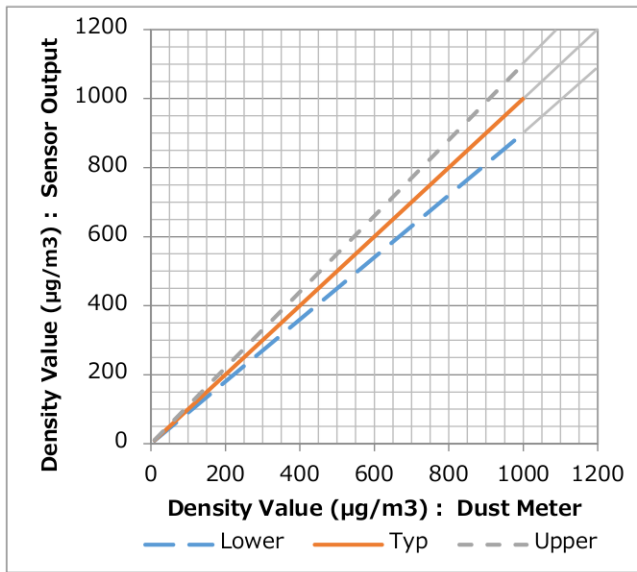

■ Standard Measurement Method

Item	for PM2.5 measurement	for PM10 measurement (technical evaluations)
Ambient temperature	26±5℃	
Room capacity	31m <sup>3</sup>	0.1m <sup>3</sup>
Test particle	Cigarette (MEVIUS or Hong Ta Shan)	JIS Test Particle 1-5, Fly Ash
Particle generator	Cigarette smoke suction machine (complies with JEM1467)	Customized particle generator
Dust meter	DUSTTRAK II Aerosol Monitor 8530 (with PM2.5 impactor)	DUSTTRAK II Aerosol Monitor 8530 (with PM10 impactor)
Test procedure	Generate smoke in the room and stir the air by electric fan. Reduce the concentration by air purifier to designated level and keep the level to measure. After stabilized, check the difference against dust meter with the average in 600 sec.	Feed the air to the test chamber with stirring test particle. Check the difference against dust meter with the average in 600 sec.
Position of test piece	Center of the room, 40~ 140cm from the floor level	Center of the test chamber
Input voltage	DC 5V±2%	

■ Auto Calibration Function

Monitor the status of light output of laser diode (LD) and the rotational speed of fan with passage of time, and the MCU controls to pump up each devices up to its control bound to keep the initial performance. After the bounds, the MCU calculate an optimal correction value and start s/w correction automatically. This function is also effective for the degradation of detection performance of Photo diode (PD), and it can make s/w correction for the dirt on the surface of PD caused by dust accumulation during the lifetime. By making these controls and corrections, the sensor maintains a certain level of performance during the lifetime (it means the measurement value will maintain center of variation against dust meter).

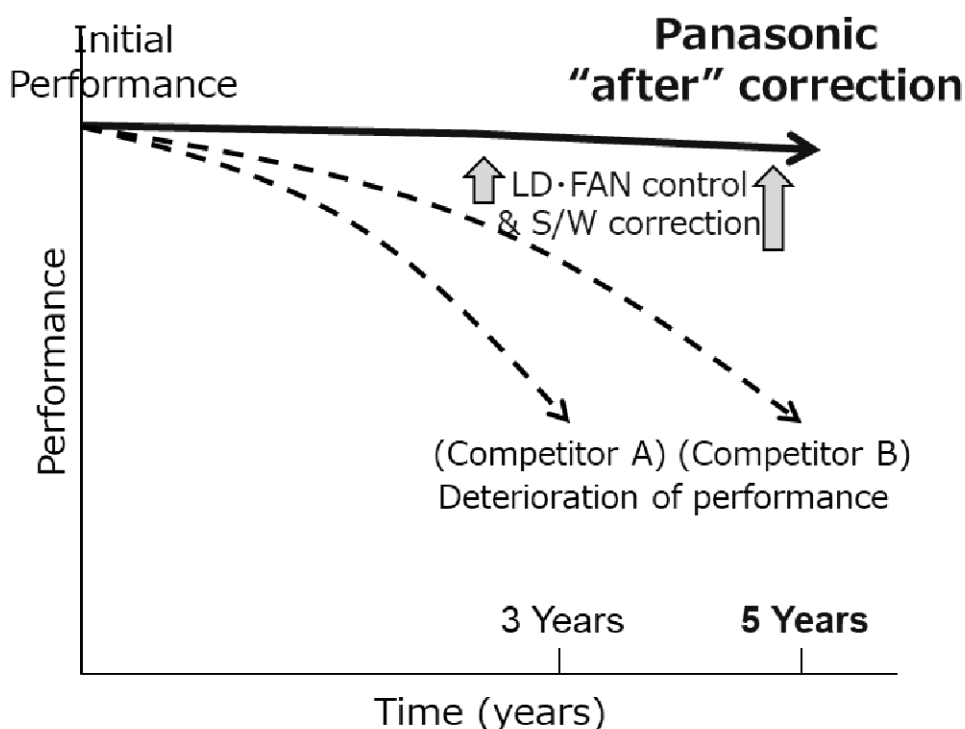
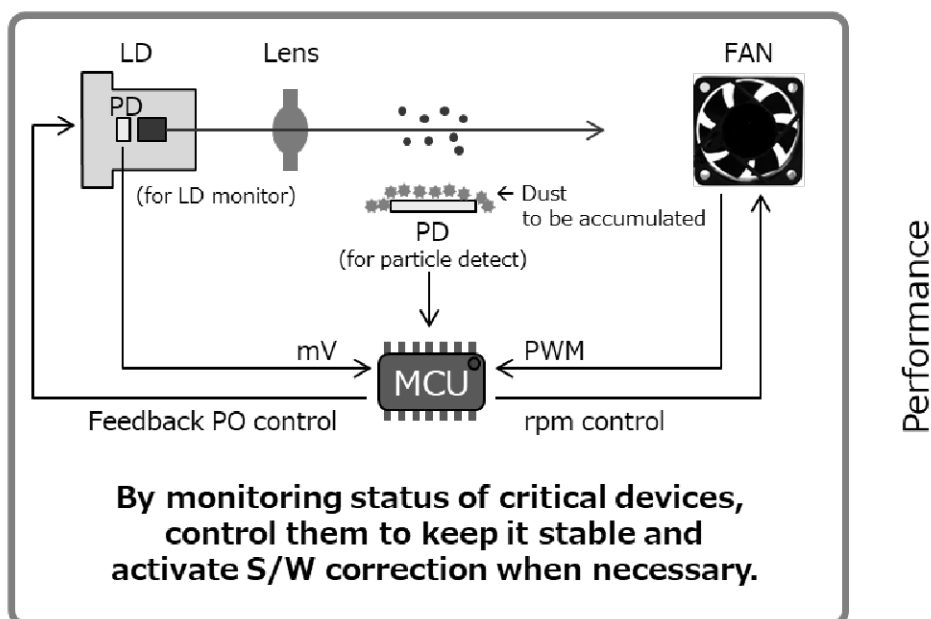

■ Reliability

Test Category	Test condition	Judgement Criteria
Drop impact	Free fall from 70cm over the ironwood Repeat 3 times in random.	No damage and crack <±15% @35-1,000µg/m <sup>3</sup>
Vibration	Frequency 10 ~ 55Hz / acceleration 1G / Sweep 1min. X、Y、Z directions each 30min.	<±15% @35-1,000µg/m <sup>3</sup>
Temperature cycle	-40 °C (30min) →(Within 10 sec)→ +80 °C (30min), 10 cycles	
THB	65°C, 90 ~ 95%RH, DC5V, 1000h	
High temp, high humidity storage	80°C, 90 ~ 95%RH, 1000h	<±15% @35-1,000µg/m <sup>3</sup>
Low temp storage	-40°C, 500h	
Power ON-OFF	45°C, 90 ~ 95%RH, ON(5min) / OFF(5min) Repeat the cycle during 500h.	No damage in functions
Open / short circuit	Open or short the each terminal of electrical components with applying operating voltage.	No firing, burning (Permit smoke generation, burnt deposit)
Tracking resistance	Drop 0.2% ammonium chloride solution with intervals 30sec, up to 200 drops.	No firing, burning (Permit smoke generation, burnt deposit)
Solder crack	-40 °C (30min) →(Within 10 sec)→ +80 °C (30min), 200 cycles.	No crack on the soldering

■ Life Duration

Under conditions in normal usage at ambient temperature 25°C, 60%RH:

LD light output : LD shall be lighted over 5 years on continuous current.

Fan motor: Fan shall be rotating over 5 years on continuous current.



■ Lot Number

3-Digit (YMD)

Production Year : 1 digit (8=2018、0=2020、1=2021)

Production Month : 1 digit (1=January、9=September、A=October、C=December)

Production Date : 1 digit (1=Day1、L=Day20、Y=Day31)

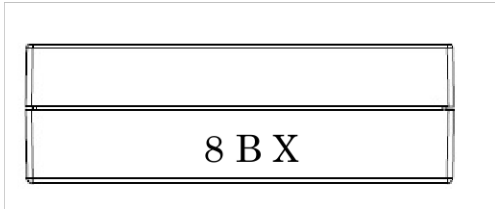

(Example) 8BX

= 2018, November 30

Y (Year)		M (Month)		D (Day)	
2018	8	Jan	1	Day1	1
2019	9	Feb	2	Day2	2
2020	0	Mar	3	Day3	3
2021	1	Apr	4	Day4	4
:	:	May	5	Day5	5
:	:	Jun	6	Day6	6
		Jul	7	Day7	7
		Aug	8	Day8	8
		Sep	9	Day9	9
		Oct	A	Day10	A
		Nov	B	Day11	B
		Dec	C	Day12	C
				Day13	D
				Day14	E
				Day15	F
				Day16	G
				Day17	H
				Day18	J
				Day19	K
				Day20	L
				Day21	M
				Day22	N
				Day23	P
				Day24	Q
				Day25	R
				Day26	S
				Day27	T
				Day28	U
				Day29	V
				Day30	X
				Day31	Y

**■ Handling Instruction**

(1) This product is supposed to use for home appliance products.

Do not use the appliance to require high reliability and safeness, like medical instrument and disaster prevention instrument, etc.

(2) When install the sensor into product, do not place any interception in front of air intake and outlet in order not to avoid intercept air flow. Also do not place sensor somewhere in a recess of the product.

(3) When install the sensor into product, make sure that the sensor would not have strong wind in the face of air intake / outlet.

(4) When install the sensor into product, fix the sensor by using screw and etc. in the product.

(5) Do not use the sensor in the strong magnetic field.

(6) Do not connect / shorted the outer shell to the terminals except GND because the shell has electric conductive and is connected to the GND.

(7) The voltage for data communication is 3.3V. Please use level shift IC or something to adjust if the driven voltage of host MCU is 5V.

(8) This product is not designed to use stand-alone. Please considerate flame resistance, compliance with the related regulations and standards at your hardware side.

(9) Do not attempt to disassemble the sensor in any case.

(10) We strive to improve the quality control, however, in general the electrical parts will fail with a certain probability. And also depend on using condition the characteristics will be changed. When install the sensor, please check the performance and reliability in actual using condition. If use with deteriorated condition, there is possibility of abnormal heating, smoking and firing. Please care regular maintenance and safety design like redundant design, fireproof design and malfunction preventing design.

**■ Others**

In case the questions arise for this specification sheet, it will be resolved by mutual agreement.

**■ Special notices**

- In case that this sensor defect is expected the influence of human life and property, we recommend from point of view product liability that install the sensor with having safety margin of this specification contents warranty characteristics and performance, and safety design like redundant design and etc.
- Please do not use or dispose (transfer, loan, diversion, license etc.) directly or indirectly for the purpose of military use in accordance to the Foreign Exchange and Foreign Trade Control Law and related ministry ordinance, etc. and export control by resolution of the United Nations Security Council. Please comply with the various regulations related to this document regarding all tangible items (deliverables, equipment, fixtures, parts, etc.) and intangible (all technologies, know-how, information, intellectual property rights, etc.)
- The contents described in this document are indicative of the characteristics of the product and do not guarantee or license the right to intellectual property rights or other rights of our company and third parties.
- Please contact us beforehand, in case of malfunction that could result to harm to the human body.
- If you find any trouble etc. in this product, please contact the sales person.
- The quality assurance of this product shall be limited to the items and their ranges described in this specification sheet. If a defect due to our company's responsibility should be identified, we will repair this product or provide alternative products. Our company shall not compensate the responsibility that your product and you get any damage by this defect. And also we are not liable for damages arising from natural disasters and inappropriate use. In case of repair and replacement, please take off the sensor from your product and return the sensor to us. If you continue to use the sensor even though the sensor is needed repair and replacement, there is possibility to get the risk in safety, please return the sensor.
- Please do not reverse engineer the product through disassembly or analysis without obtaining permission from our company
- Please understand beforehand that specifications and appearance of this product may be changed without prior notice for improvement.

■ Product Outline Drawing

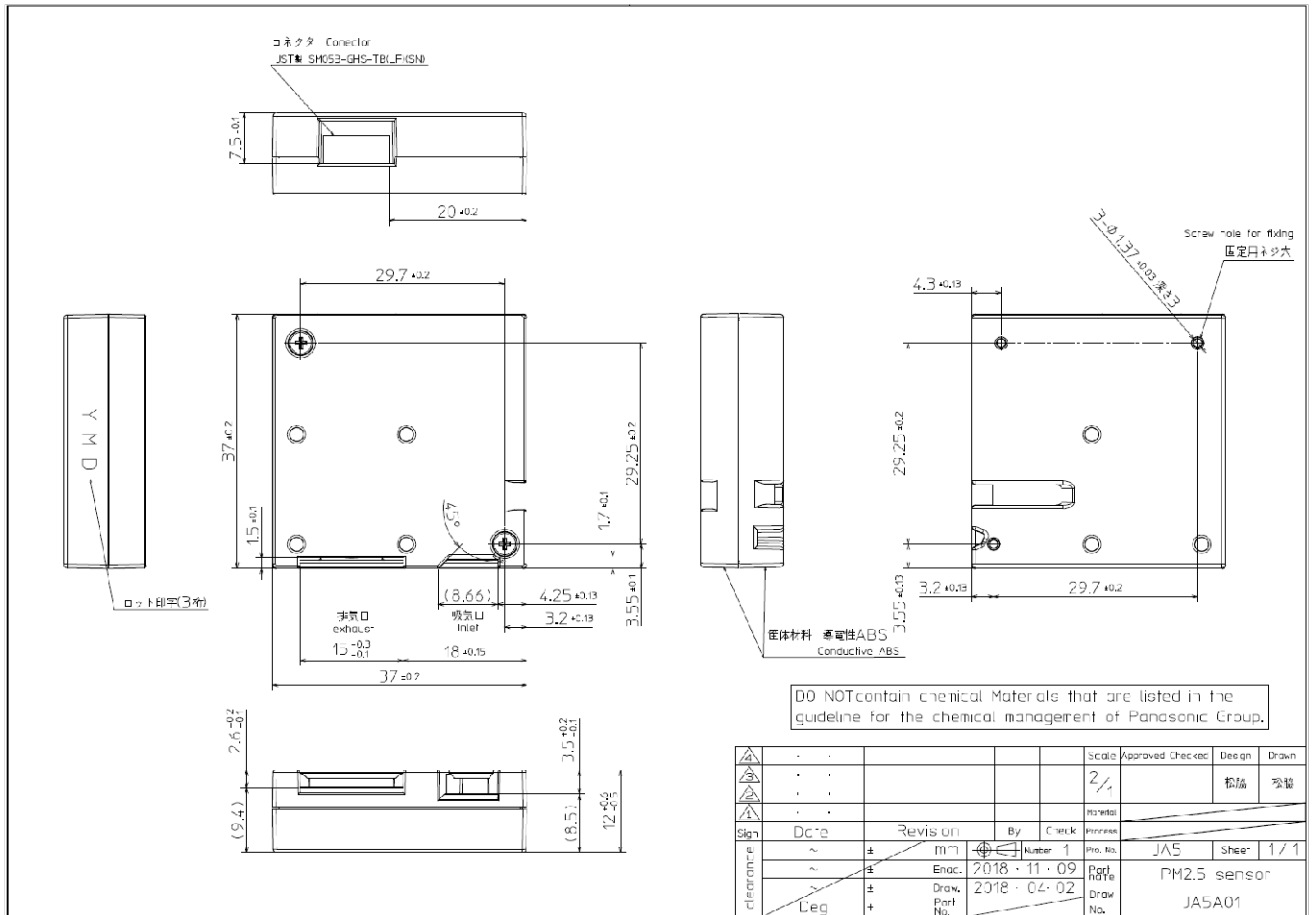

■ Packaging Spec

パナソニックグループ(化学物質ラック指針最新版に基づく化学物質を含有していないこと)  
DO NOT contain chemical Materials that are listed in the guideline for the chemical management of Panasonic Group.

注記  
1. 外装箱の寸法は内寸とする。  
2. 印刷は片面のみ行う。

Note)  
1. Described dimension is inside dimension.  
2. Print on only one side.

JA5 トレイ(部番:027A501F)  
JA5 Tray(027A501F)

静電防止ポリ袋(部番:02799A11F)  
Antistatic poly bag(02799A11F)

HA1 側板(部番:027A121F)  
HA1 side plate (027A121F)

空トレイ 1枚  
(1 empty tray)

1枚(50×入り)×6枚  
=300×入り  
50 products/tray × 6tray  
=300 products

トレイ積の単位販売 7枚  
(各段に積み重ねる等  
を行う時は)

HA1 下敷板(部番:027A121F)  
HA1 selling board (027A121F)

HA1 側板(部番:027A121F)  
HA1 side plate (027A121F)

テープ&のり封止  
Seal the box with taping  
& glue in 3 directions as 'H'

待装箱口(幅A300×入り)

↑ 表向き  
This side up

↑ fragile  
Fragile

↑ 乾燥注意  
Keep dry

待装箱口(内寸:488×244×175)  
BC:700×110  
1部番:027KR124F)

Outer carton D  
(内寸:Shimdan:488×244×175)  
BC:700  
1部番:027KR124F)

片側センター位置に  
待装箱を貼り付ける  
Paste an identification tag  
on the center of  
one side of the outer carton.

△	-	-	-	-	Scale	Approved	Checked	Design	Drawn
△	-	-	-	-	File			松崎	松崎
△	-	-	-	-	Material	図中参照	Reference in figure.		
△	-	-	-	-	Process	図中参照	Reference in figure.		
△	-	-	-	-	Part No.	JA5	Sheet	1 / 1	
△	-	-	-	-	Part Name	包装仕様書			
△	-	-	-	-	Draw Date	2018_07_02			
△	-	-	-	-	Draw Part No.			JA5Z01	A3

Panasonic Photo & Lighting Co., Ltd.