

## CHROMINANCE DEMODULATOR FOR SECAM OR PAL/SECAM DECODERS

The TCA650 is an integrated synchronous demodulator for both the SECAM and PAL chrominance signals.

Switching of the standard is performed internally, controlled by an external applied d. c. signal.

In addition to the synchronous demodulator, which delivers colour difference signals, the circuit also incorporates:

- a PAL matrix, used for adding the delayed and non-delayed signals to obtain separately the (R-Y) and (B-Y) components of the chrominance signal.
- a PAL switch, which reverses the phase of the (R-Y) component of the chrominance signal on alternating lines.
- a SECAM switch, which performs the separation of the  $D_R$  and  $D_B$  components of the chrominance signal by switching the delayed and non-delayed signals.
- a SECAM limiter.

QUICK REFERENCE DATA			
Supply voltage		$V_{14-2}$ nom.	12 V
Supply current		$I_{14}$ nom.	36 mA
Chrominance input signals (peak-to-peak value)	$V_{1-2(p-p)}$ $V_{3-2(p-p)}$	typ.	PAL
			SECAM
			200 mV
System switch input	$V_{4-2}$	typ.	12 V
Colour difference output signals (peak-to-peak value)	(R-Y): $V_{12-2(p-p)}$	typ.	1, 1 V
	(B-Y): $V_{10-2(p-p)}$	typ.	1, 47 V
Reference input signals (PAL) (peak-to-peak value)	$V_{6-2(p-p)}$ $V_{7-2(p-p)}$	typ.	1 V
Square-wave input (peak-to-peak value)	$V_{16-2(p-p)}$	typ.	3 V

### PACKAGE OUTLINE

16-lead DIL; plastic (SOT-38).

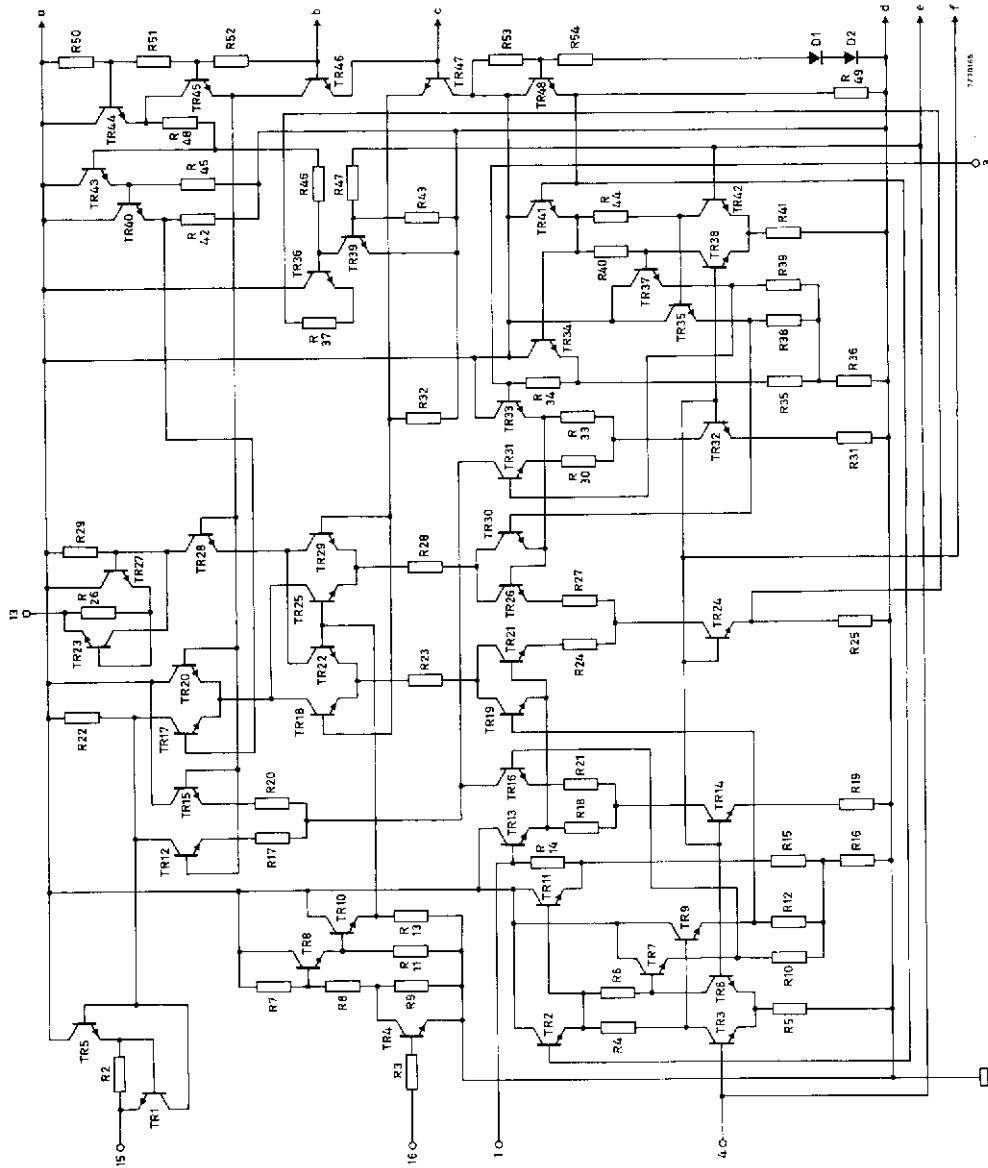

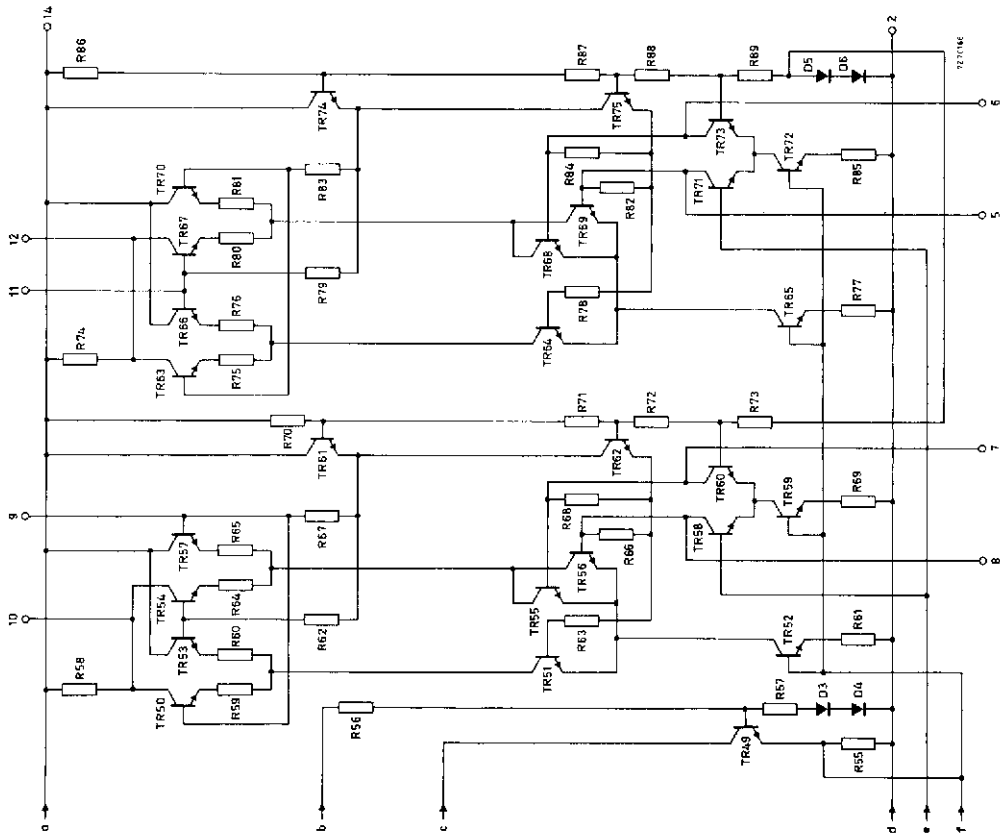

**RATINGS** Limiting values in accordance with the Absolute Maximum System (IEC 134)

Voltage

Supply voltage  $V_{14-2}$  max. 13,2 V

Power dissipation

Total power dissipation  $P_{tot}$  max. 510 mW

Temperatures

Storage temperature  $T_{stg}$  -25 to +125 °C

Operating ambient temperature  $T_{amb}$  -25 to +65 °C<sup>1)</sup>

**CHARACTERISTICS** measured in the circuit on page 6

Supply voltage  $V_{14-2}$  typ. 12 V  
10,2 to 13,2 V

Required input signals at  $V_{14-2} = 12$  V and  $T_{amb} = 25$  °C

Chrominance input signal

peak-to-peak value  $V_{1-2(p-p)}$  } PAL 35 to 75 mV  
 $V_{3-2(p-p)}$  } SECAM 150 to 400 mV

Input impedance

$|Z_{1-2}|$  } 1,2 to 2,6 kΩ  
 $|Z_{3-2}|$  }

PAL matrix

Gain from both inputs to pin 13 2,3 to 3,3

Gain from both inputs to pin 15 2,6 to 3,6

Gain difference from line-to-line < 5 %

Phase errors from line-to-line in the (R-Y) output for zero error in the (B-Y) output < 2,5°

Output impedance  $|Z_{13-2}|$  } < 100 Ω  
 $|Z_{15-2}|$  }

SECAM permutator

Diaphotie < -46 dB

Output signal (peak-to-peak value)  $V_{13-2(p-p)}$  } 1,6<sup>2)</sup> to 2,2 V  
 $V_{15-2(p-p)}$  }

Output impedance  $|Z_{13-2}|$  } < 100 Ω  
 $|Z_{15-2}|$  }

1) When a stabilized power supply of  $\approx 12$  V is applied,  $T_{amb}$  is max. 75 °C.

2) At an input voltage of 0,15 V; at an input voltage  $> 0,2$  V the figure is 1,7 V.

**CHARACTERISTICS** (continued)Demodulator

## Chrominance input signal amplitude

PAL: (B-Y); peak-to-peak value	$V_{9-2}(p-p)$	typ. 0,22 V
(R-Y); peak-to-peak value	$V_{11-2}(p-p)$	typ. 0,28 V
SECAM: peak-to-peak value	$V_{9-2}(p-p)$ } $V_{11-2}(p-p)$ }	1,5 to 3 V
Input impedance	$ Z_{9-2} $ } $ Z_{11-2} $ }	> 1 k $\Omega$
Reference input signal amplitude		
PAL: peak-to-peak value	$V_{6-2}(p-p)$ } $V_{7-2}(p-p)$ }	0,5 to 1,5 V
SECAM: peak-to-peak value	$V_{5-2}(p-p)$ } $V_{8-2}(p-p)$ }	0,18 <sup>1)</sup> to 1,5 V
Input impedance	$ Z_{5-2} $ ; $ Z_{7-2} $ } $ Z_{6-2} $ ; $ Z_{8-2} $ }	0,75 to 1,25 k $\Omega$

Colour difference output signal

(R-Y); peak-to-peak value	$V_{12-2}(p-p)$	0,99 to 1,21 V <sup>2)</sup>
(B-Y); peak-to-peak value	$V_{10-2}(p-p)$	1,32 to 1,62 V <sup>2)</sup>
Output impedance	$ Z_{10-2} $ } $ Z_{12-2} $ }	2,4 to 4,2 k $\Omega$

Diaphotie at SECAM operation

Diaphotie of the total circuit at frequencies corresponding to saturated green

$D_R = 4,72$  MHz and  $D_B = 4,04$  MHz < -40 dB

Square wave input

peak-to-peak value	$V_{16-2}(p-p)$	2,5 to 3,5 V
Input impedance	$ Z_{16-2} $	> 3,8 k $\Omega$

System switch input <sup>3)</sup>

PAL:	7 to $V_{14-2}$	V
SECAM:	0 to 1	V

<sup>1)</sup> Limiting starts at the quoted value.

<sup>2)</sup> The peak-to-peak clipping level for PAL is about 4,7 V for (B-Y) and 3 V for (R-Y). The discriminator characteristic allows a maximum peak-to-peak output signal of 3,6 V for (B-Y) and 2,4 V for (R-Y) (SECAM).

<sup>3)</sup> The switching signal is applied to pin 4 via a resistor of 2,7 k $\Omega$  ( $\pm 10\%$ ).

## APPLICATION INFORMATION

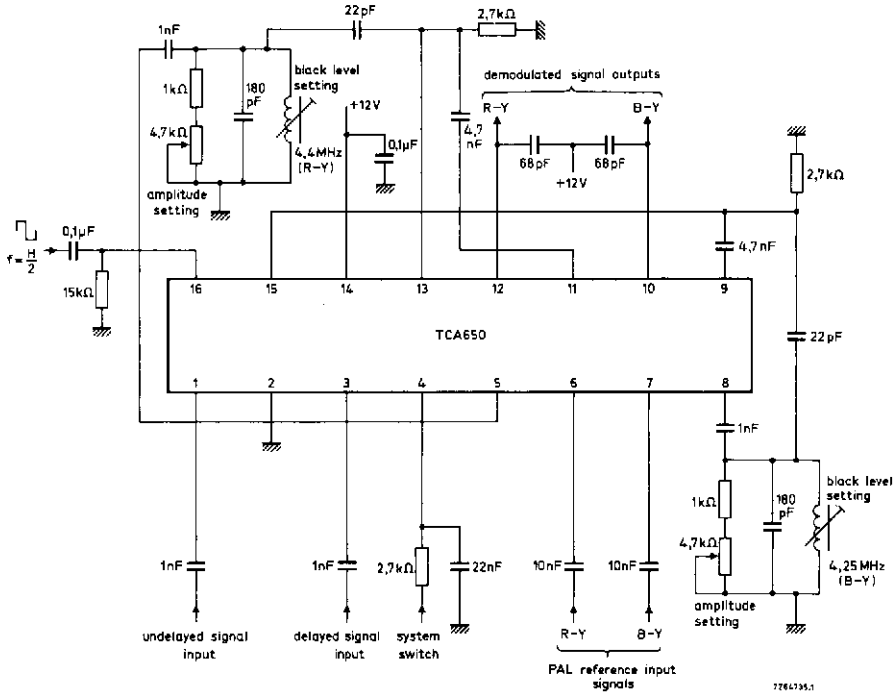

### Pinning

- |                                |                                     |
|--------------------------------|-------------------------------------|
| 1. Chrominance input           | 9. Chrominance (B-Y), $D_B$ input   |
| 2. Earth (negative supply)     | 10. Colour difference (B-Y) output  |
| 3. Chrominance input           | 11. Chrominance (R-Y), $D_R$ input  |
| 4. System switch input         | 12. Colour difference (R-Y) output  |
| 5. Reference (R-Y) input SECAM | 13. Chrominance (R-Y), $D_R$ output |
| 6. Reference (R-Y) input PAL   | 14. Supply voltage (12 V)           |
| 7. Reference (B-Y) input PAL   | 15. Chrominance (B-Y), $D_B$ output |
| 8. Reference (B-Y) input SECAM | 16. Square wave input               |

**APPLICATION INFORMATION** (continued)

The function is quoted against the corresponding pin number

1. Chrominance input

The blanked composite chrominance signal from pin 1 of the TCA640 is applied to this input via a resistive divider.

2. Negative supply (earth)3. Chrominance input

The blanked composite chrominance signal from pin 15 of the TCA640 is applied to this input via a delay-line, which has a delay time of 64  $\mu$ s.

4. System switch input

The control voltage for switching the standard is applied to this input via a resistor of 2,7 k $\Omega$  ( $\pm$  10%). A decoupling capacitor of at least 10 nF is recommended. Between 7 V and the supply voltage the circuit operates in the PAL mode, whereas between 0 V and 1 V the mode SECAM is selected.

5. Reference input for the (R-Y) demodulator

The SECAM reference signal is applied to this pin. The reference signal is obtained from pin 11 via a tank circuit. The tank circuit is tuned such that the level at the (R-Y) output (pin 12) during black ( $f_0 = 4,4$  MHz) equals the level during blanking (no signal). The output voltage amplitude at pin 12 can be adjusted by damping the tank circuit.

6. Reference input for the (R-Y) demodulator

A PAL reference signal having (R-Y) phase is applied to this pin.

7. Reference input for the (B-Y) demodulator

A PAL reference signal having (B-Y) phase is applied to this pin.

8. Reference input for the (B-Y) demodulator

The SECAM reference signal is applied to this pin. The reference signal is obtained from pin 15 via a tank circuit. The tank circuit is tuned such that the level at the (B-Y) output (pin 10) during black ( $f_0 = 4,25$  MHz) equals the level during blanking (no signal). The output voltage amplitude at pin 10 can be adjusted by damping the tank circuit.

9. Chrominance input to the (B-Y),  $D_B$  demodulator

The output signal of pin 15 is applied via a coupling capacitor of 4,7 nF.

10. Output of the (B-Y) demodulator

The output signal of the balance demodulator contains an r.f. ripple of twice the chrominance frequency to be filtered by a  $\pi$  filter. At SECAM the required de-emphasis circuit should be applied.

11. Chrominance input to the (R-Y),  $D_R$  demodulator

The output signal of pin 13 is applied via a coupling capacitor of 4,7 nF.



**APPLICATION INFORMATION** (continued)12. Output of the (R-Y) demodulator

See pin 10.

13. Chrominance (R-Y),  $D_R$  output

The (R-Y) component of the chrominance signal ( $D_R$  component at SECAM) is present at this pin.

The signal is applied to the input of the (R-Y) demodulator (pin 11) and to the tank circuit for the SECAM reference signal.

The emitter follower output should be loaded with a 2,7 k $\Omega$  resistor to obtain an output impedance of <100  $\Omega$ .

14. Supply voltage (12 V)

Correct operation occurs within the range 10,2 to 13,2 V.

The power dissipation must not exceed 510 mW at 65 °C ambient temperature.

15. Chrominance (B-Y),  $D_B$  output

The (B-Y) component of the chrominance signal ( $D_B$  component at SECAM) is present at this pin.

The signal is applied to the input of the (B-Y) demodulator (pin 9) and to the tank circuit for the SECAM reference signal.

The emitter follower output should be loaded with a 2,7 k $\Omega$  resistor to obtain an output impedance of <100  $\Omega$ .

16. Square wave input

A square wave with an amplitude of 3 V drives the PAL switch or the SECAM permutator.

The square wave is available at pin 12 of the TCA640.

