

HOW TO ORDER CUSTOM DRAWING

T-16 SH + DRAWING NUMBER (Max. 16 digits)

This way of ordering should be used for options which are not included in the "How to order" standard and optional extras.

STANDARD OPTIONS

Shaft length 0 standard length
 Detents Not included
 Stereo matching Only for model "T" and upon request
 Switch No switch
 Nut & washer Without nut and washer

MODELS WITH METALIC SHAFTS

T-16 S ...

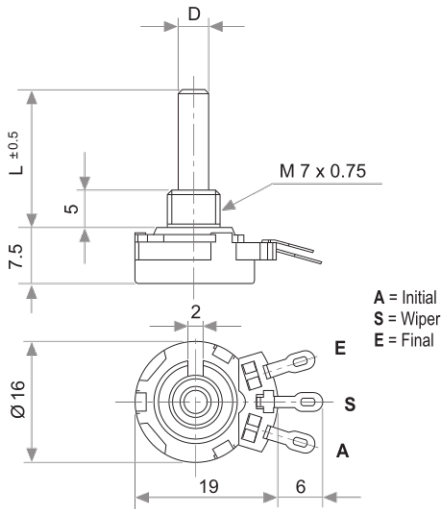

A = Initial
 S = Wiper
 E = Final

T-16 T ...

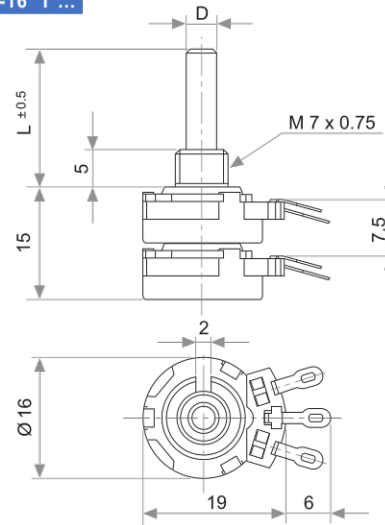

MODELS WITH PLASTIC SHAFTS

T-16 X ...

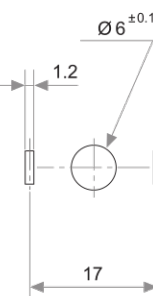
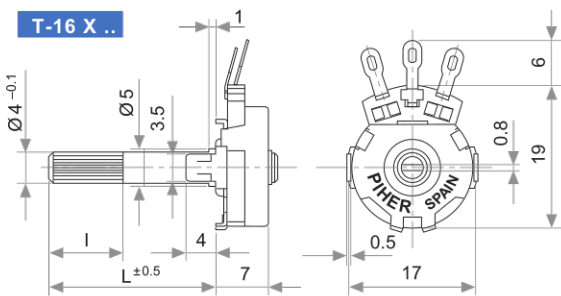

T-16 W ...

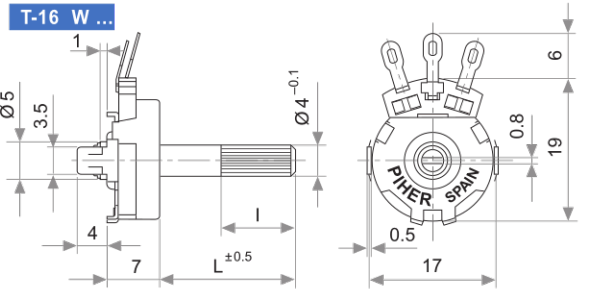

T-16 Y ...

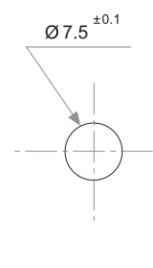
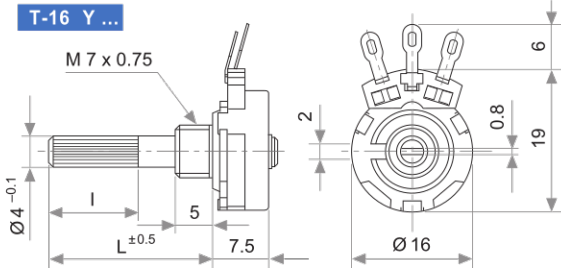

T-16 Z ...

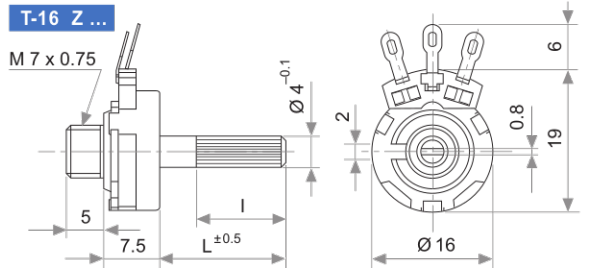

TERMINALS

T-16 .. C ...

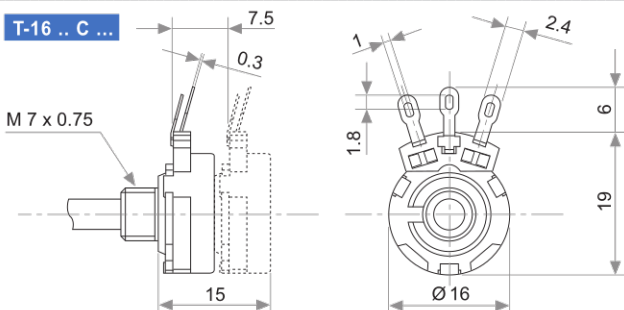

T-16..H..

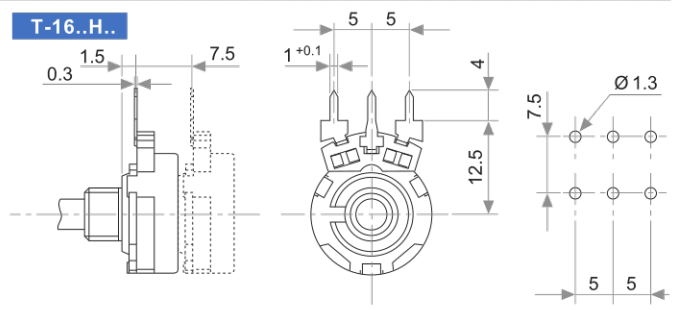

T-16 .. V ...

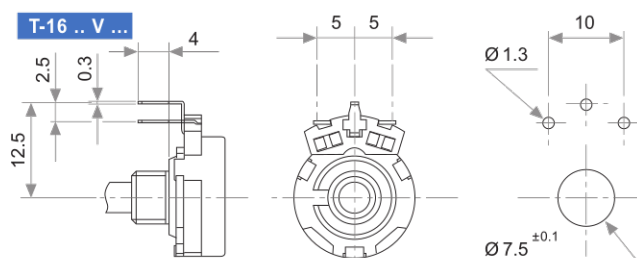

T-16..L..

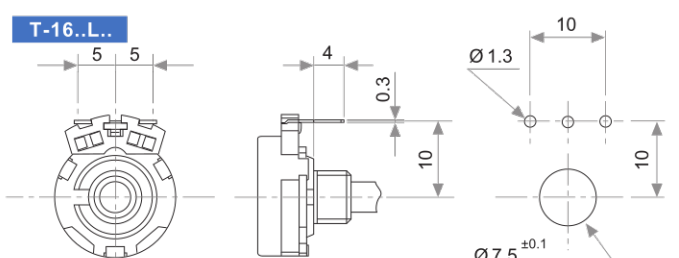

PLASTIC SHAFTS

T-16 X / Y Without Switch				
T-16 X		T-16 Y		CODE
L	I	L	I	
2	—	—	—	P01
21	12	20.5	12	P02
24.5	15	24	15	P03
40	31	39.5	31	P04

T-16 W / Z Without Switch		
T-16 W & T-16 Z	CODE	
L	I	
9.5	5	P05
23.5	19	P06
40	35	P07

METALIC SHAFTS

PLAIN SHAFT

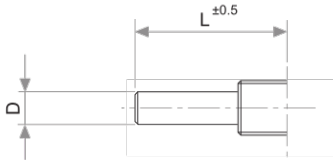

D	L	CODE
3	30	M03
4	40	M04
6	40	M06
6.25	40	M07
3/4	40/30	M05

KNURLED SHAFT

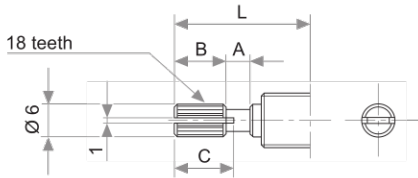

L	A	B	C	CODE
15	2	6	7	M11
20	2	10	11	M12
25	4	12	14	M13
30	4	12	14	M14
35	4	12	14	M15
40	4	12	14	M16

UNDER DRAWING

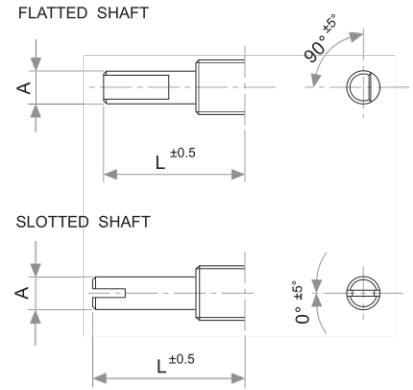

BUSHINGS

T-16 .. N ...

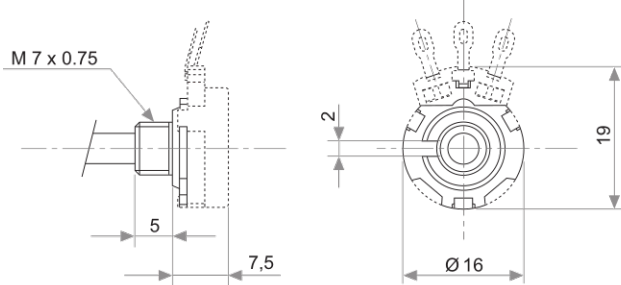

T-16 .. U ...

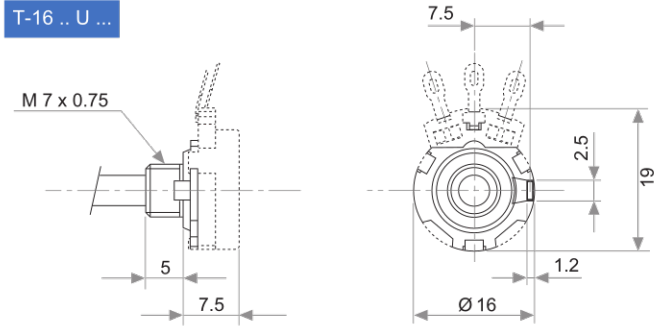

DETENTS

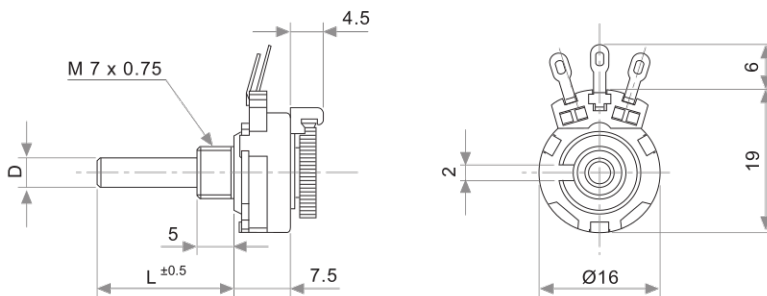

CODE	DETENTS
01 P.	1 detent (at 50%)
11 P.	11 detents
41 P.	41 detents

Only models with metallic shaft.

TAPERS

Standard

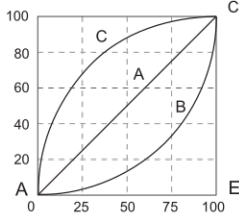

A: Lin.
B: Log.
C: Alog.

POWER RATING CURVE

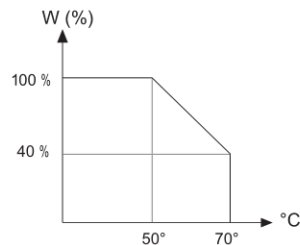

NUT & WASHER

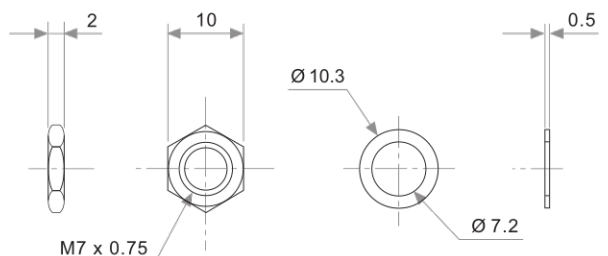

TESTS		TYPICAL VARIATIONS
ELECTRICAL LIFE	1.000 h.@ 50°C; 0.20 W	± 5 %
MECHANICAL LIFE : POT. SWITCH	25.000 (10-15 CPM) 10.000 (1A, 50 VAC)	± 3 % (Rn < 1 MΩ)
TEMPERATURE COEFFICIENT	-25°C; +70°C	± 300 ppm (Rn < 100 K)
THERMAL CYCLING	16 h. @ 85°C; 2h. @ -25°C	± 2.5 %
DAMP HEAT	500 h. @ 40°C @ 95% HR	± 5 %
VIBRATION (each plane X,Y,Z)	2 h. @ 20 g, 10 Hz ... 55 Hz.	± 2 %

NOTE: Out of range values may not comply these results.

SWITCH

T-16..C..C

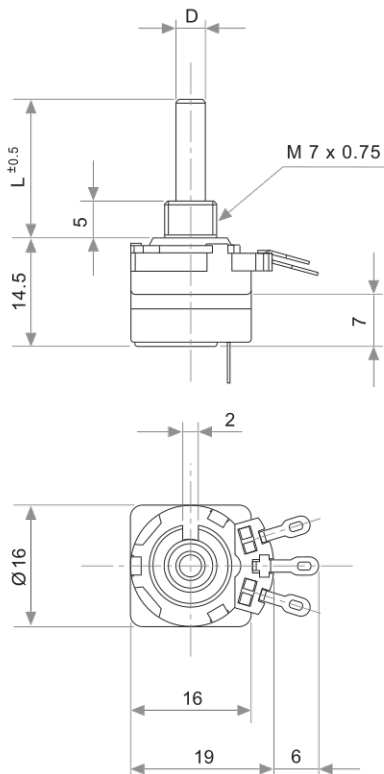

T-16..H..I

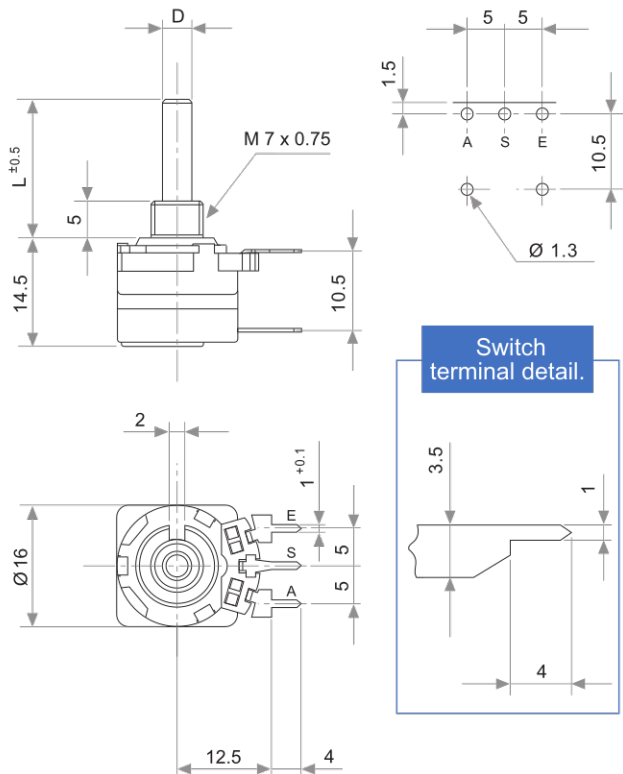

SWITCH SPECIFICATIONS

NOMINAL CURRENT	1A, 250 VAC
CONTACT RESISTANCE (Initial)	10 mΩ
OPERATING TORQUE	1 to 3 Ncm (1.4 to 4.2 in-oz)
OPERATING ANGLE	30° ± 5°
TEST VOLTAGE	500 V

PACKAGING

MODEL	PACKAGING
T 16 – L = 40 mm.	400 UNITS IN BOX
T 16 – L = 20 mm.	600 UNITS IN BOX
T 16 – c/i – Tandem	200 UNITS IN BOX