

Features

- available in MRT package
- high breakdown voltage:
 $BV_{CEO} = 80\text{ V}$
- large current capacity, $I_C = 700\text{ mA}$
- complementary pair with 2SB1330

Applications

- medium power amplifier

Dimensions (Units : mm)

2SD2006 (MRT)

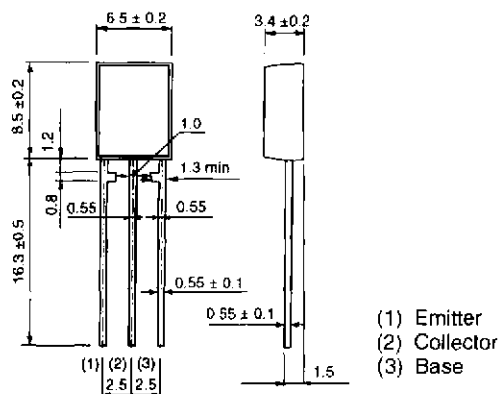
**Absolute maximum ratings ($T_a = 25^\circ\text{C}$)**

Parameter	Symbol	Limits	Unit	Conditions
Collector-to-base voltage	V_{CBO}	80	V	
Collector-to-emitter voltage	V_{CEO}	80	V	
Emitter-to-base voltage	V_{EBO}	5	V	
Collector current	I_C	700	mA	Continuous (dc)
		1	A	Single pulse, width 100 ms
Collector dissipation	P_C	1.2	W	
Junction temperature	T_j	150	$^\circ\text{C}$	
Storage temperature	T_{sig}	-55 ~ +150	$^\circ\text{C}$	

Electrical characteristics (unless otherwise noted, $T_a = 25^\circ\text{C}$)

Parameter	Symbol	Min	Typical	Max	Unit	Conditions
Collector-to-base breakdown voltage	BV_{CBO}	80			V	$I_C = 50 \mu\text{A}$
Collector-to-emitter breakdown voltage	BV_{CEO}	80			V	$I_C = 2 \text{ mA}$
Emitter-to-base breakdown voltage	BV_{EBO}	5			V	$I_E = 50 \mu\text{A}$
Collector cutoff current	I_{CBO}			0.5	μA	$V_{CB} = 50 \text{ V}$
Emitter cutoff current	I_{EBO}			0.5	μA	$V_{EB} = 4 \text{ V}$
DC current gain	h_{FE}	82		390		$V_{CE} = 3 \text{ V}, I_C = 100 \text{ mA}$
Collector-to-emitter saturation voltage	$V_{CE(sat)}$		0.2	0.4	V	$I_C/I_B = 500 \text{ mA}/50 \text{ mA}$
Transition frequency	f_T		120		MHz	$V_{CE} = 10 \text{ V}, I_E = -50 \text{ mA}, f = 100 \text{ MHz}$
Output capacitance	C_{ob}		10		pF	$V_{CB} = 10 \text{ V}, I_E = 0 \text{ A}, f = 1 \text{ MHz}$

h_{FE} rankings

Item	P	Q	R
h_{FE}	82 ~ 180	120 ~ 270	180 ~ 390

Electrical characteristic curves

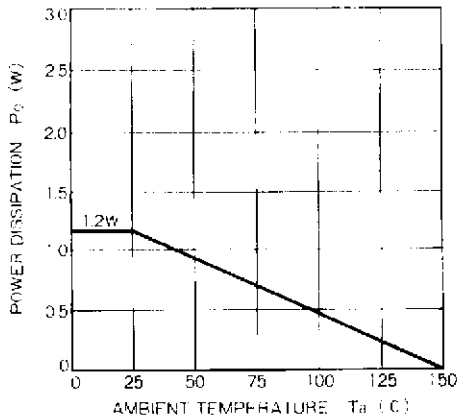

Figure 1

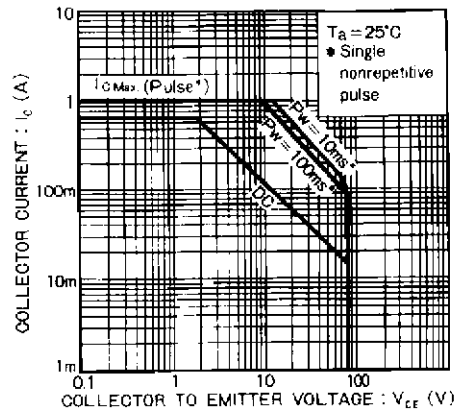

Figure 2

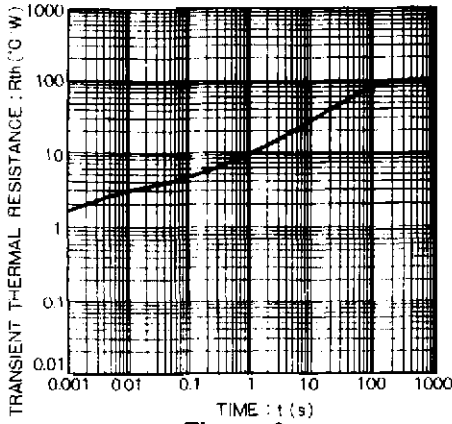

Figure 3

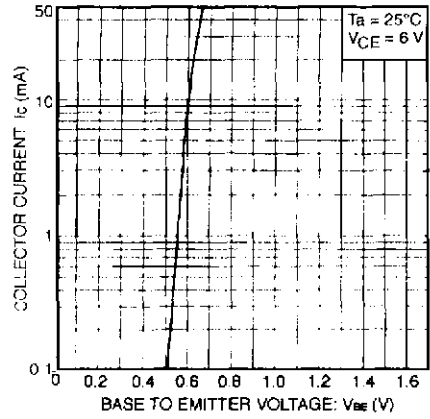

Figure 4

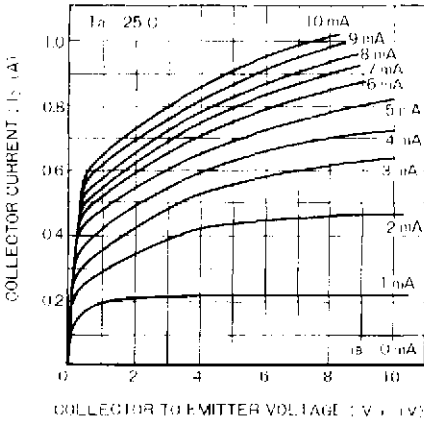

Figure 5

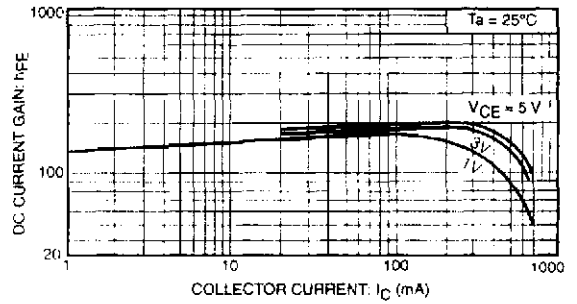

Figure 6

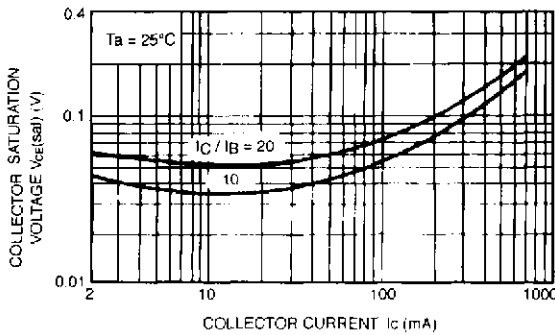

Figure 7

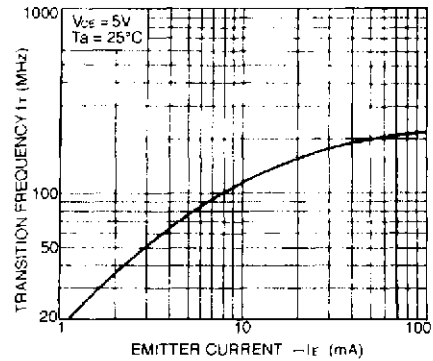

Figure 8

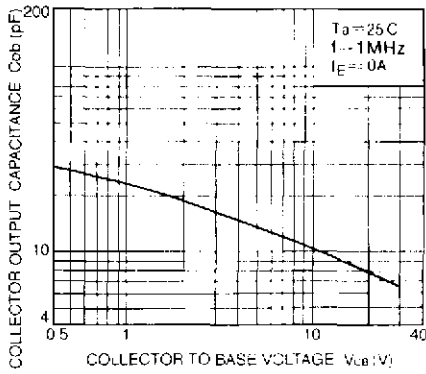

Figure 9

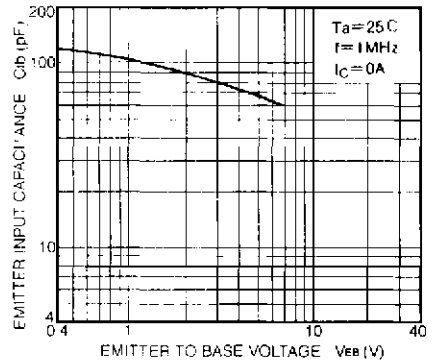

Figure 10

Ordering information

Package	Tape
Code	T105
Basic order quantity	2 000
2SD2006	★
★ = Standard, ☆ = Semi-standard, * = Special order	