

Video signal switcher

BA7604N

The BA7604N is a switching IC developed for use in VCRs. It has two-channel analog multiplexers, and features wide dynamic range, and wide operating frequency range, and is suitable for switching audio and video signals.

●Applications
VCRs and TVs

●Features

- 1) Two 2-input / 1-output switches.
- 2) 5V power supply.
- 3) Low power consumption (42mW Typ.).
- 4) Excellent frequency characteristics (10MHz, 0dB, Typ.).
- 5) Wide dynamic range (3.0V_{P-P} Typ.).
- 6) High input impedance (20kΩ Typ.).
- 7) Fast switching speed (50ns Typ.).

●Absolute maximum ratings (Ta = 25°C)

Parameter	Symbol	Limits	Unit
Power supply voltage	V _{CC}	9	V
Power dissipation	P _d	500*	mW
Operating temperature	T _{opr}	- 40 ~ + 85	°C
Storage temperature	T _{stg}	- 55 ~ + 125	°C

* Reduced by 5.0mW for each increase in Ta of 1°C over 25°C.

●Block diagram

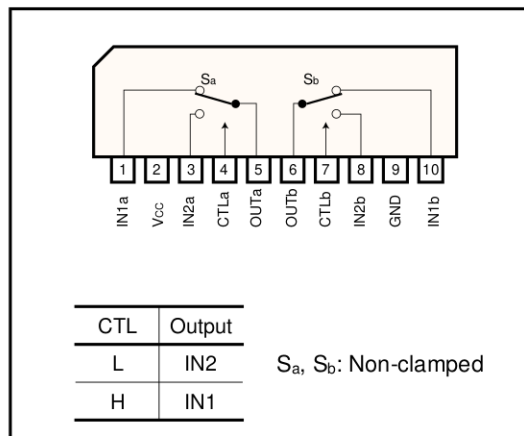

●Equivalent circuits

Sa, Sb

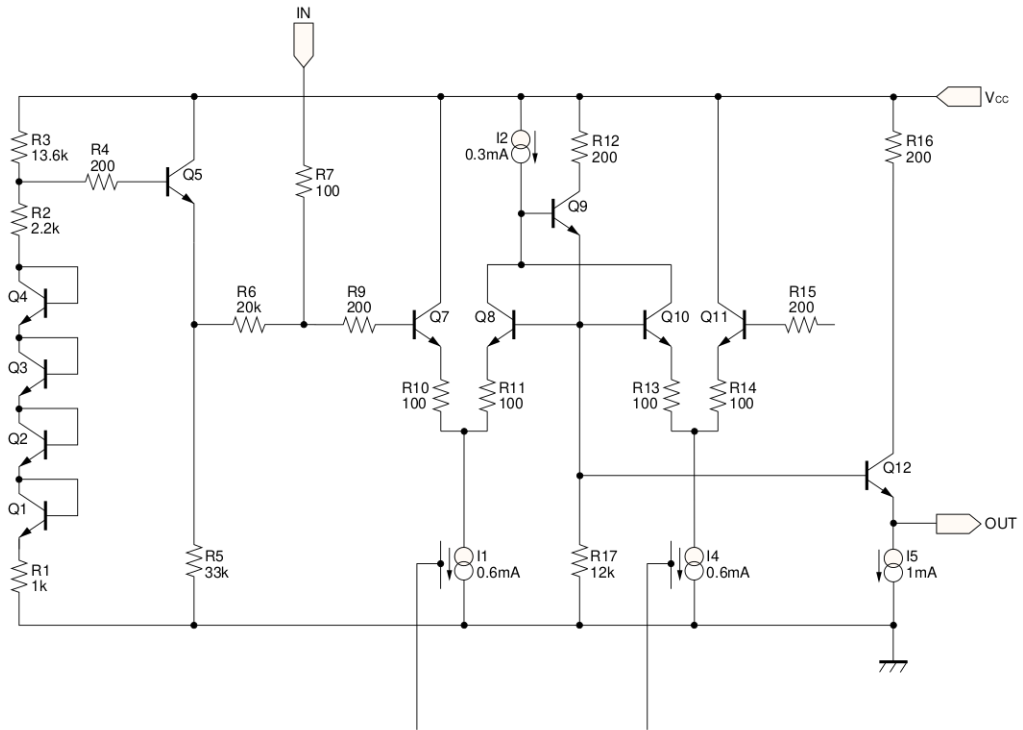

CTL

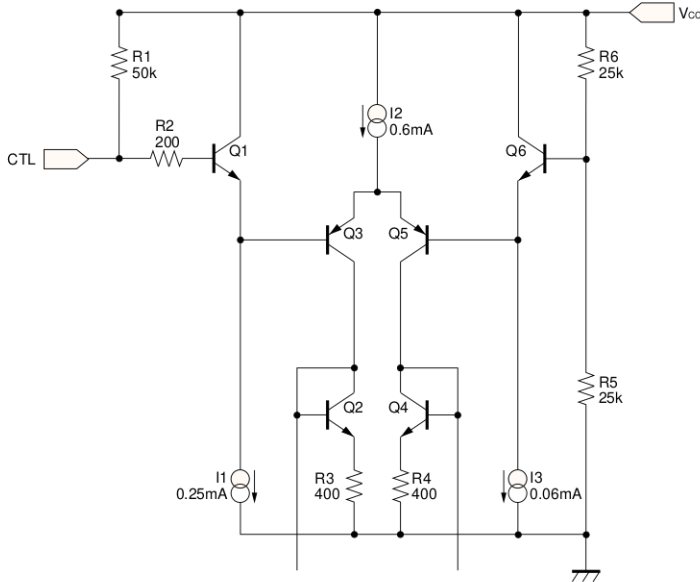

●Electrical characteristics (unless otherwise noted, Ta = 25°C and V_{CC} = 5.0V)

Parameter	Symbol	Min.	Typ.	Max.	Unit	Conditions
Operating voltage	V _{CC}	4.5	5.0	5.5	V	—
Supply current	I _{CC}	—	8.4	13.0	mA	—
Maximum output level	V _{om}	2.7	3.0	—	V _{P-P}	f = 1kHz, THD = 0.5%
Voltage gain	G _V	-0.5	0	0.5	dB	f = 1MHz, V _{IN} = 1V _{P-P}
Interchannel crosstalk	C _T	—	-65	—	dB	f = 4.43MHz, V _{IN} = 1V _{P-P}
Frequency characteristic	G _f	-3	0	1	dB	10MHz / 1MHz, V _{IN} = 1V _{P-P}
Total-harmonic distortion	THD	—	0.007	—	%	f = 1MHz, V _{IN} = 1V _{P-P}
CTL pin switch level	V _{TH}	2.0	2.5	3.0	V	—
Input impedance	Z _{IN}	14	20	26	kΩ	—

Note: Refer to the measurement circuit given in Fig. 1.

●Reference data

Pin DC voltages (reference values)

Units: Vdc

Pin No.	DC voltage	Pin No.	DC voltage
1	2.48	6	1.76
2	5.00	7	4.91
3	2.48	8	2.48
4	4.91	9	0
5	1.76	10	2.48

Electrical characteristics

Parameter	Min.	Typ.	Max.	Unit
Input impedance (no clamp)	—	20k	—	Ω
Output impedance	—	30	—	Ω

The input coupling capacitor values should be 0.1μF to 1μF.

● Measurement circuit

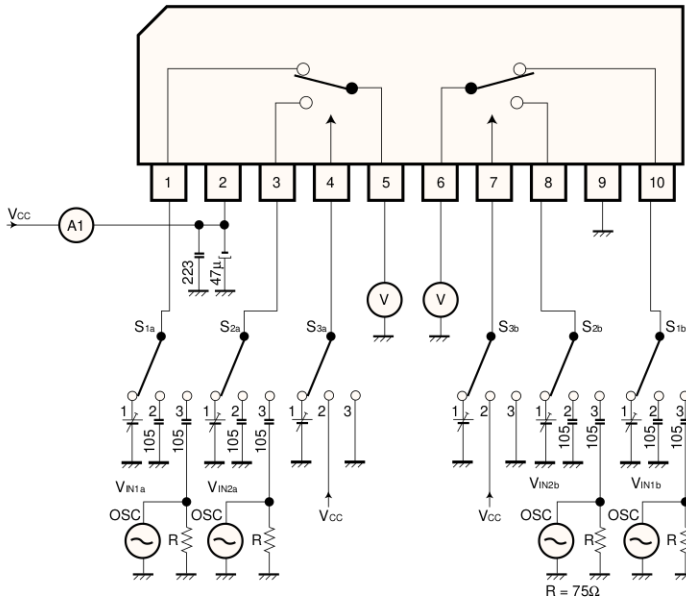

● Measurement conditions

Parameter		Symbol	Switch settings						Measurement method
			S _{1a}	S _{2a}	S _{3a}	S _{1b}	S _{2b}	S _{3b}	
Current dissipation		I _{CC}	2	2	2	2	2	2	Ammeter
Maximum output level	IN1a	V _{om}	3	2	2	2	2	2	Note 1
	IN2a	V _{om}	2	3	3	2	2	2	
	IN1b	V _{om}	2	2	2	3	2	2	
	IN2b	V _{om}	2	2	2	2	3	3	
Voltage gain	IN1a	G _V	3	2	2	2	2	2	Note 2
	IN2a	G _V	2	3	3	2	2	2	
	IN1b	G _V	2	2	2	3	2	2	
	IN2b	G _V	2	2	2	2	3	3	
Interchannel crosstalk	IN1a	C _T	2	3	2	2	2	2	Note 3
	IN2a	C _T	3	2	3	2	2	2	
	IN1b	C _T	2	2	2	2	3	2	
	IN2b	C _T	2	2	2	3	2	3	
Frequency characteristic	IN1a	G _f	3	2	2	2	2	2	Note 4
	IN2a	G _f	2	3	3	2	2	2	
	IN1b	G _f	2	2	2	3	2	2	
	IN2b	G _f	2	2	2	2	3	3	
CTL pin switching level	CTLa	V _{TH}	3	2	1	2	2	2	Note 5
	CTLb	V _{TH}	2	2	2	3	2	1	
Total-harmonic distortion	IN1a	THD	3	2	2	2	2	2	Note 6
	IN2a	THD	2	3	3	2	2	2	
	IN1b	THD	2	2	2	3	2	2	
	IN2b	THD	2	2	2	2	3	3	
Input impedance	IN1a	Z _{IN}	1	2	2	2	2	2	Note 7
	IN2a	Z _{IN}	2	1	3	2	2	2	
	IN1b	Z _{IN}	2	2	2	1	2	2	
	IN2b	Z _{IN}	2	2	2	2	1	3	

Note 1: Connect a distortion meter to the output, and input a $f = 1\text{kHz}$ sine wave. Adjust the output level until the output distortion is 0.5%. This output voltage at this time is the maximum output level V_{om} (V_{P-P}).

Note 2: Input a $1V_{P-P}$, 1MHz sine wave. The voltage gain is given by $G_V = 20 \log (V_{OUT} / V_{IN})$.

Note 3: Input a $1V_{P-P}$, 4.43MHz sine wave. The interchannel crosstalk is given by $C_T = 20 \log (V_{OUT} / V_{IN})$.

Note 4: Input $1V_{P-P}$, 1MHz and 10MHz sine waves. The frequency characteristic is given by $G_f = 20 \log (V_{OUT} (f = 10\text{MHz}) / V_{OUT} (f = 1\text{MHz}))$.

Note 5: Input a $1V_{P-P}$, 1MHz sine wave. Reduce the CTL pin voltage from V_{CC} . The CTL pin switching level (V_{TH}) is the CTL pin voltage at which the V_{OUT} level drops below $20mV_{P-P}$.

Note 6: Input a $1V_{P-P}$, 1kHz sine wave and measure the total-harmonic distortion of the output using a total-harmonic distortion meter.

Note 7: Measure the input pin voltage V_{IN50} when a current of $DC50\mu A$ is flowing into the input pin. Measure the input pin open-circuit voltage. The input impedance is given by $Z = (V_{IN50} - V_{INO}) / 50 \times 10^{-6}[\Omega]$.

● External dimensions (Units: mm)

