

SANYO

No.1833B

LA2220

ARI System For Car Radio
(SK Type, Nonadjusting VCO)

The LA2220 is a traffic decoder (SK) IC designed for ARI (Autofahrer Rundfunk Informationen) now in effect in Europe. It permits complete non-adjusting and provides a malfunction preventing function at the RDS (or PI system) reception mode.

Features

- The use of a 456kHz ceramic resonator, 57kHz BPF eliminates the need to adjust free-running frequency and also eliminates the need to use a coil, permitting complete non-adjusting.
- The BK signal detector is provided as a measure against malfunction at the RDS (or PI system) reception mode. The SK signal and BK signal are ANDed to provide LED display.
- The lighting level can be changed by C, R connected to the BPF externally.
- SK signal only can be detected for automatic search use. (Pin 16 SK-STOP)
- The lighting level can be raised by applying DC voltage. (Pin 17 $V_{SK-CONT}$)
- Single-end 22-pin package permitting good space factor.

Functions

- SK operation: 57kHz(SK) and 23.75 to 53.98Hz(BK) are ANDed to provide LED display.
Composite signal is controlled.(Muting)
- Muting switch: When pin 4 is grounded, the signal is through regardless of the presence or absence of SK, BK. LED display by SK + BK is provided.
- Oscillation stop switch: When voltage (5.5V to $V_{CC}-1.4V$) is applied to pin 20, the OSC stops operating and the signal is through. LED display is turned OFF.
- DK, BK output: The 57kHz AM detector delivers DK, BK signals. When oscillation stops, detection operation stops.
- SK stop: The presence of 57kHz(SK) sets pin 16 voltage to "L". Used as the stop signal at the automatic search mode: 57kHz-SK presence/absence
→ $V_{16}=0V/3.6V$
- Lighting level control: When voltage is applied to pin 17, the 57kHz(SK) detect level rises. Used to prevent LED from lighting mistakenly at the weak signal mode.

Package Dimensions 3066

(unit: mm)

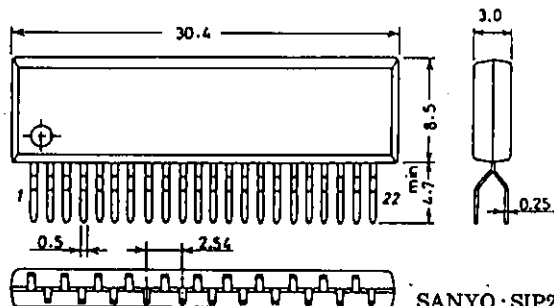

SANYO: SIP22S

SANYO Electric Co., Ltd. Semiconductor Business Headquarters
TOKYO OFFICE Tokyo Bldg., 1-10, 1 Chome, Ueno, Taito-ku, TOKYO, 110 JAPAN

12894TH/D227KI/1225KI, TS No.1833-1/3

Maximum Ratings at Ta=25°C

				unit
Maximum Supply Voltage	V _{CC} max	V ₁₋₁₀	16	V
		V ₁₁₋₁₀	16	V
Maximum Flow-in Current		I ₃	1	mA
Lamp Drive Current	I _L max	I ₁₁	30	mA
Allowable Power Dissipation	Pdmax		574	mW
Operating Temperature	Topg		-30 to +80	°C
Storage Temperature	Tstg		-40 to +125	°C

Operating Conditions at Ta=25°C

				unit
Recommended Supply Voltage	V _{CC}		8	V
Operating Voltage Range	V _{CC} op		7 to 12	V
Input Signal Voltage	V _{in}	100%mod	200 to 300	mV
		f=57kHz	10 to 15	mV
Lamp Drive Current	I _L		1 to 25	mA

Operating Characteristics at Ta=25°C, V_{CC}=8V, v_{in}=200mV, L+R=85%, 19kHz pilot=10%, 57kHz pilot=5%, f=1kHz

			min	typ	max	unit
Quiescent Current	I _{cco}		17	24	34	mA
Input Resistance	r _i			40k		ohm
SK Detect Level	V _{SK}	f=57kHz, pin 2 input	2.5	3.6	5.5	mV
SK Hysteresis	hy _{SK}	"		5.5		dB
BK Detect Level	V _{BK}	f=23.75Hz, pin 12 input		17		mV
BK Hysteresis	hy _{BK}	"		3		dB
Capture Range	CR	f=57kHz, v _{in} =10mV		±1.2		%
Output Level	VoAF	f=1kHz, v _{in} =200mV	147	210	294	mV
DK Output Level	VoDK	f=57kHz, v _{in} =10mV, 125Hz-30%mod	27	38	54	mV
Total Harmonic Distortion	THD	f=1kHz, v _{in} =200mV	0.13	0.5		%
Signal Attenuation	V _{MUTE}	f=1kHz, DIN-AUDIO filter	-60	-75		dB

Equivalent Circuit Block Diagram (Including Peripheral Circuit)

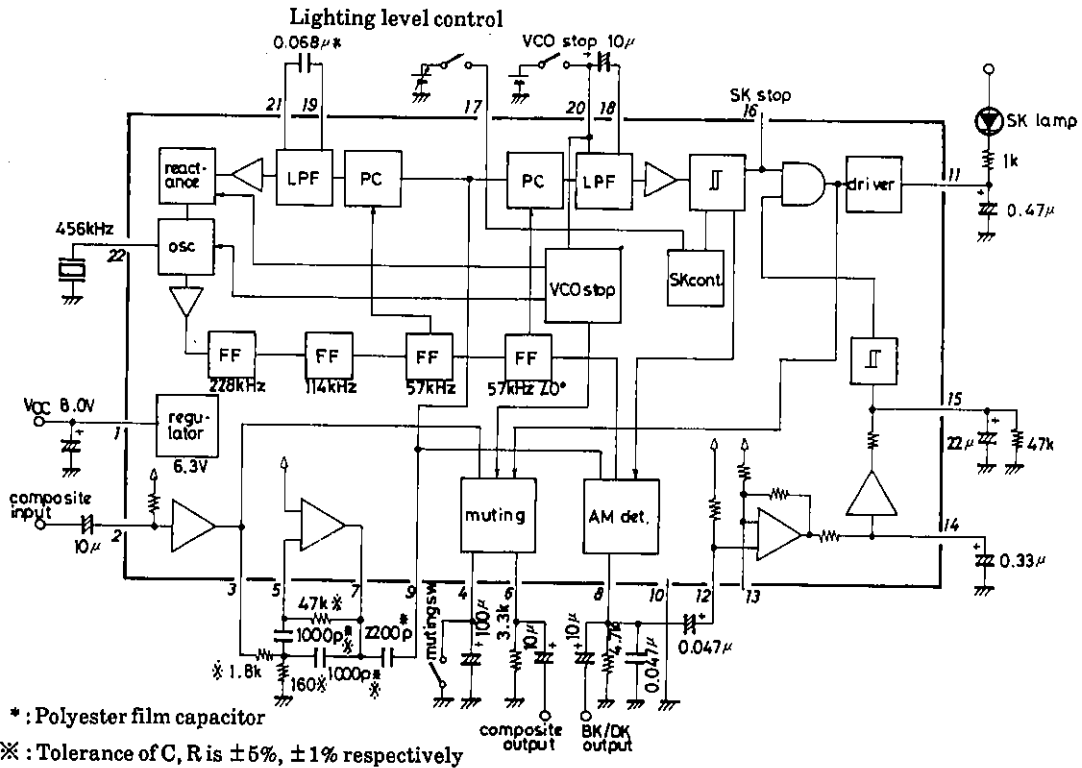

Unit (resistance: Ω, capacitance: F)

Sample Application Circuit

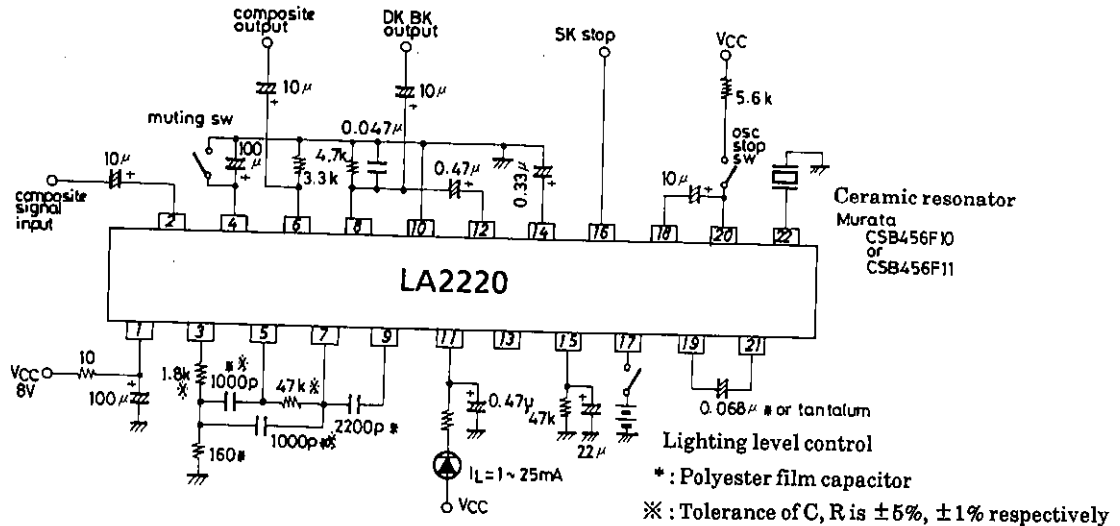
Unit (resistance: Ω , capacitance: F)

[Remarks]

An experimental broadcasting of a new system called "RDS (Radio Data System)" is now in operation in West Germany.

The RDS is a data transmission system capable of identifying large amounts of information in addition to the SK, DK, BK signals. Digital signals are used to identify the country, broadcast area, program, traffic information channel, traffic information announcement, music/speech, monaural/stereo, frequency, date and time, etc.

When the RDS broadcasting is received with the SK decoder of the ordinary PLL system, the SK lamp may be lighted mistakenly. This mistaken lighting is caused by the use of 57kHz pilot signal in both ARI and RDS systems. The ARI system uses a 57kHz AM-modulated signal and the RDS system uses a 57kHz carrier-suppressed DSB (double side band) signal.

If the capture range of the PLL is narrow enough, the DSB (57kHz \pm 1.1875kHz) of the RDS signal is not captured. For PLL IC's of CR oscillation type, however, the capture range cannot be made too narrow because of free-running frequency drift. The PLL is locked in the RDS signal and the SK lamp is lighted, releasing the SK muting. There is no simple method to prevent this malfunction from occurring. If a peripheral circuit is used as a measure against this malfunction, seven transistors are required.

We have developed 'LA2220' in which a measure against this malfunction is taken. This IC is capable of detecting the BK signal as well as the SK signal (incapable of distinguishing among areas A to F). Only when both SK and BK signals are present, the SK lamp is lighted. For the RDS broadcasting with no BK signal, the lamp is not lighted and no SK malfunction occurs.

- No products described or contained herein are intended for use in surgical implants, life-support systems, aerospace equipment, nuclear power control systems, vehicles, disaster/crime-prevention equipment and the like, the failure of which may directly or indirectly cause injury, death or property loss.
- Anyone purchasing any products described or contained herein for an above-mentioned use shall:
 - ① Accept full responsibility and indemnify and defend SANYO ELECTRIC CO., LTD., its affiliates, subsidiaries and distributors and all their officers and employees, jointly and severally, against any and all claims and litigation and all damages, cost and expenses associated with such use:
 - ② Not impose any responsibility for any fault or negligence which may be cited in any such claim or litigation on SANYO ELECTRIC CO., LTD., its affiliates, subsidiaries and distributors or any of their officers and employees jointly or severally.
- Information (including circuit diagrams and circuit parameters) herein is for example only; it is not guaranteed for volume production. SANYO believes information herein is accurate and reliable, but no guarantees are made or implied regarding its use or any infringements of intellectual property rights or other rights of third parties.