

## AUTOMATIC VOLTAGE SWITCH (SMPS < 500W)

### CONTROLLER

- 50/60Hz FULL COMPATIBILITY
- INTEGRATED VOLTAGE REGULATOR
- TRIGGERING PULSE TRAIN OF THE TRIAC
- PARASITIC FILTER
- LOW POWER CONSUMPTION

### TRIAC

- HIGH EFFICIENCY AND SAFETY SWITCHING
- UNINSULATED PACKAGE : AVS12CB
- $V_{DRM} = \pm 600\text{ V}$
- $I_{T(RMS)} : 12\text{ A}$

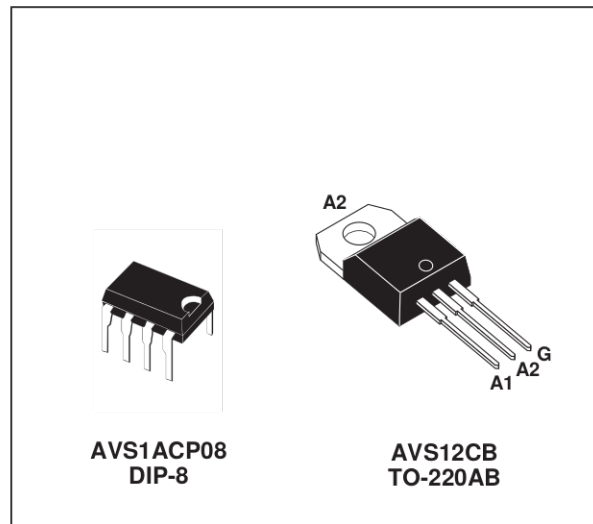

### DESCRIPTION

The AVS12 kit is an automatic mains selector (110/220V AC) to be used in SMPS < 500 W. It is composed of 2 devices :

- The **Controller** is optimized for low consumption and high security triggering of the triac. When connected to  $V_{SS}$ , the **mode** input activates an additional **option**. If the main power drops from 220V to 110V, the triac control remains locked to the 220V mode and avoids any high voltage spike when the voltage is restored to 220V. When connected to  $V_{DD}$ , the mode input desactivates this option.
- The **TRIAC** is specially designed for this application. An optimization between sensitivity and dynamic parameters of the triac gate highly reduces the losses of supply resistor and allows excellent immunity against disturbances.

### PIN CONNECTION

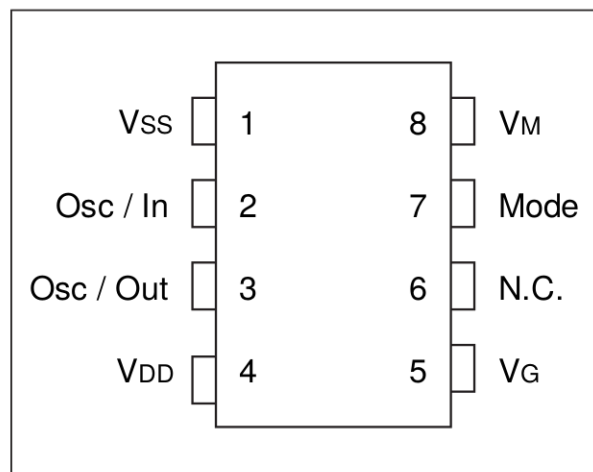

# AVS12

## BLOCK DIAGRAM

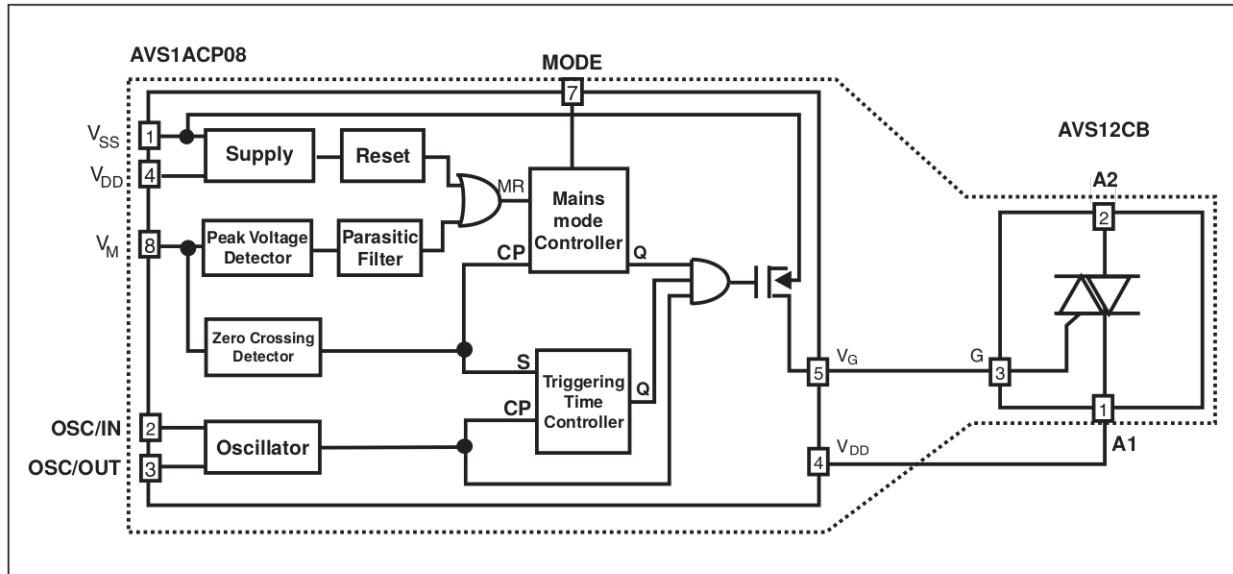

## ABSOLUTE MAXIMUM RATINGS CONTROLLER AVS1ACP08

Symbol	Parameter	Value		Unit
		Min.	Max.	
V <sub>SS</sub>	Supply voltage	-12	0.5	V
V <sub>I</sub> / V <sub>O</sub>	I / O voltage	V <sub>SS</sub> - 0.5	0.5	V
I <sub>I</sub> / I <sub>O</sub>	I / O current	-40	+40	mA
T <sub>stg</sub>	Storage Temperature	-60	+150	°C
T <sub>oper</sub>	Operating Temperature code "C"	0	+70	°C

## TRIAC AVS12CB T<sub>j</sub> = +25°C (unless otherwise specified)

Symbol	Parameter	Value	Unit
V <sub>DRM</sub>	Repetitive peak off-state voltage (2)	± 600	V
I <sub>T(RMS)</sub>	RMS on-state current (360° conduction angle)	T <sub>C</sub> = 70°C 12	A
I <sub>TSM</sub>	Non repetitive surge peak on-state current ( T <sub>j</sub> initial = 25°C )	t = 8.3ms t = 10ms 105 100	A
I <sup>2</sup> t	I <sup>2</sup> t value	t = 10ms 50	A <sup>2</sup> s
di / dt	Critical rate of rise of on-state current (1)	Repetitive F = 50Hz 20 Non Repetitive 100	A/μs
dV/dt *	Linear slope up to 0.67 V <sub>DRM</sub> Gate open	T <sub>j</sub> = 110°C 50	V/μs
T <sub>stg</sub> T <sub>j</sub>	Storage Temperature Junction Temperature Range	- 40 + 150 0 + 125	°C

(1) Gate supply : I<sub>G</sub> = 100mA - di/dt = 1A/μs  
(2) T<sub>j</sub> = 110°C

\* For either polarity of electrode A2 voltage with reference to electrode A1

**THERMAL RESISTANCE**  
TRIAC AVS12CB

Symbol	Parameter	Value	Unit
Rth (j-a)	Junction to ambient	60	°C/W
Rth (j-c) DC	Junction to case for DC	3	°C/W
Rth (j-c) AC	Junction to case for 360° conduction angle (F = 50Hz)	2.3	°C/W

**DC GENERAL ELECTRICAL CHARACTERISTICS**  
TRIAC AVS12CB

Symbol	Parameter	Value		Unit
		Min.	Max.	
V <sub>GD</sub>	V <sub>D</sub> = V <sub>DRM</sub> RL = 3.3kΩ Pulse duration > 20μs T <sub>j</sub> = 110°C	0.2		V
V <sub>TM</sub> *	I <sub>TM</sub> = 17A t <sub>p</sub> = 10ms T <sub>j</sub> = 25°C		1.75	V
I <sub>DRM</sub> *	V <sub>DRM</sub> rated Gate open T <sub>j</sub> = 25°C		10	μA
		T <sub>j</sub> = 110°C	500	

\* For either polarity of electrode A2 voltage with reference to electrode A1

**Fig. 1:** Maximum RMS power dissipation versus RMS on-state current (F = 60Hz). (Curves are cut off by (di/dt)<sub>c</sub> limitation)

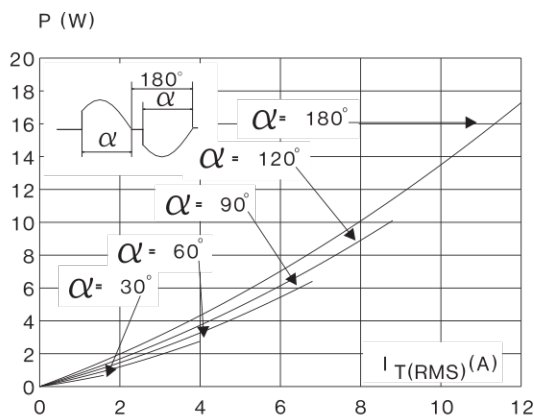

**Fig. 2:** Correlation between maximum mean power dissipation and maximum allowable temperature (T<sub>amb</sub> and T<sub>case</sub>) for different thermal resistances heatsink + contact.

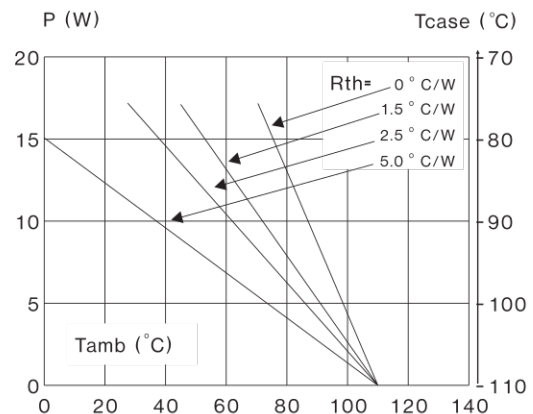

**Fig. 3:** Non repetitive surge peak on-state current for a sinusoidal pulse with width:  $t \leq 0\text{ms}$ , and corresponding value of  $I^2t$ .

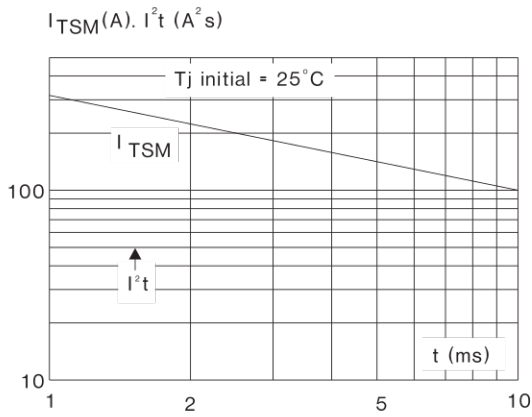

**Fig. 4:** On-state characteristics (maximum values).

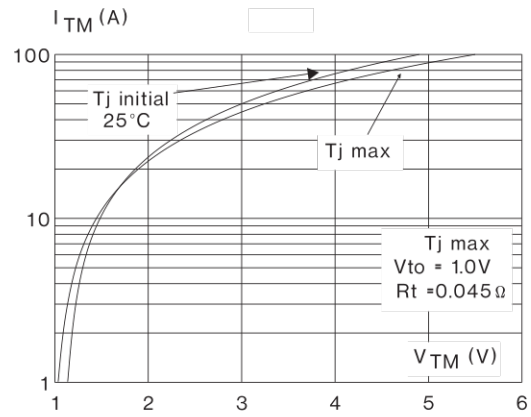

**DC GENERAL ELECTRICAL CHARACTERISTICS** (continued)  
 CONTROLLER AVS1ACP08 Toper = 25°C (unless otherwise specified)

Symbol	Parameter	Value			Unit
		Min.	Typ.	Max.	
$V_{SS}$ (pin 1) (Vreg)	Shunt regulator	-10	-9	-8	V
$I_{SS}$ (pin 1) (Vreg) (@ $V_{SS} = 9\text{V}$ )	Supply current	0.4		30	mA
$I_{SS}$ (pin 1) (@ triac gate non connected)	Quiescent current			0.7	mA
F (pin 3) (@ $R = 91\text{k}\Omega$ ) ( $C = 100\text{pF}$ )	Oscillator frequency	42	44	46	KHz
$V_M$ (pin 8) $V_{th}$ (3)	Peak voltage of detection high-threshold	4.08	4.25	4.42	V
$V_M$ (pin 8) $V_h$ (3)	Peak voltage of detection hysteresis	0.370	0.4	0.420	V
(1) $V_M$ (pin 8) $V_{th}$ (3)	Zero-crossing detection high-threshold	95	110	125	mV
$V_M$ (pin 8) $V_h$ (3)	Zero-crossing detection hysteresis	27	50	80	mV
(2) $V_{razht}$ (4)	Power-on-reset activation threshold		$V_{reg} \times 0.89$		V
(2) $V_{razlt}$ (4)	Power-down-reset activation threshold	3		6.5	V
Mode (pin 7)	$V_{IL}$ (4) $V_{IH}$ (4)	0.7 $V_{reg}$		0.3 $V_{reg}$	V

**NOTE:**

- (1) : This value gives a typical noise immunity on the zero-crossing detection of  $110\text{mV} \times 1018/18 = 6.20\text{V}$  on the main supply
- (2) : See following diagram
- (3) : Voltage referred to  $V_{SS}$
- (4) : Voltage referred to  $V_{DD}$

POWER-ON AND POWER-OFF RESET BEHAVIOUR

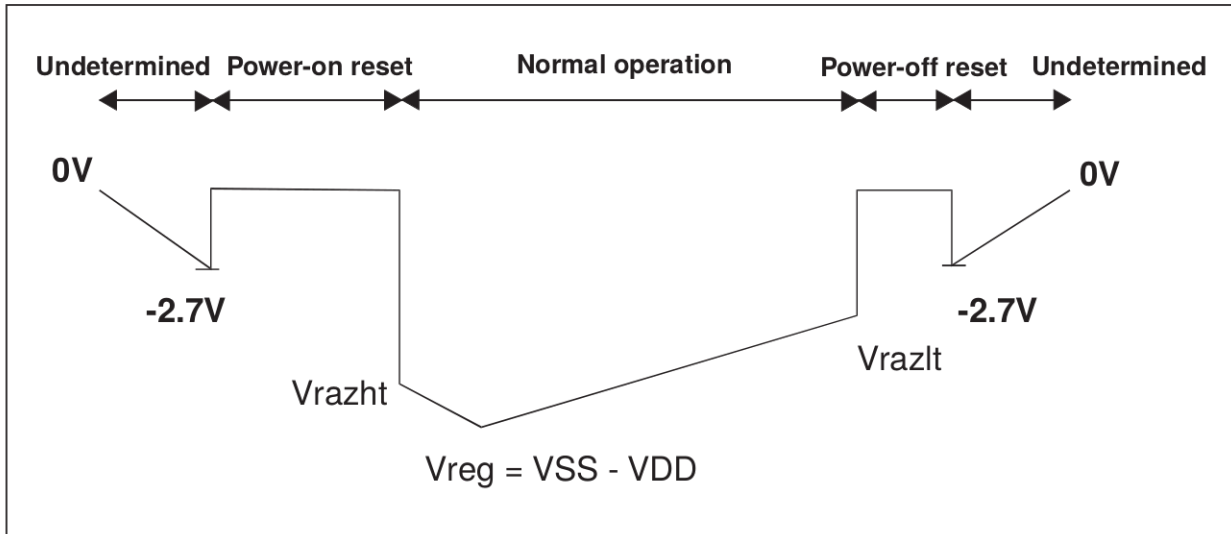

TYPICAL APPLICATION

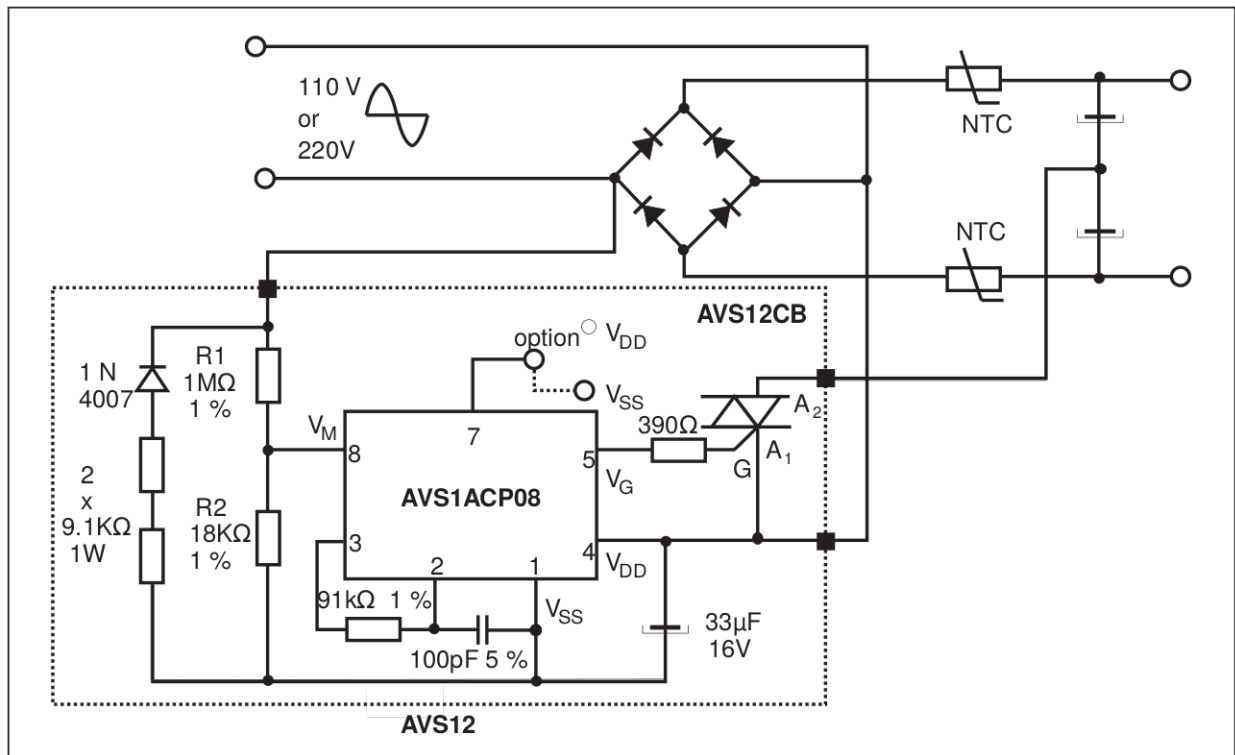

# AVS12

## ORDERING INFORMATION

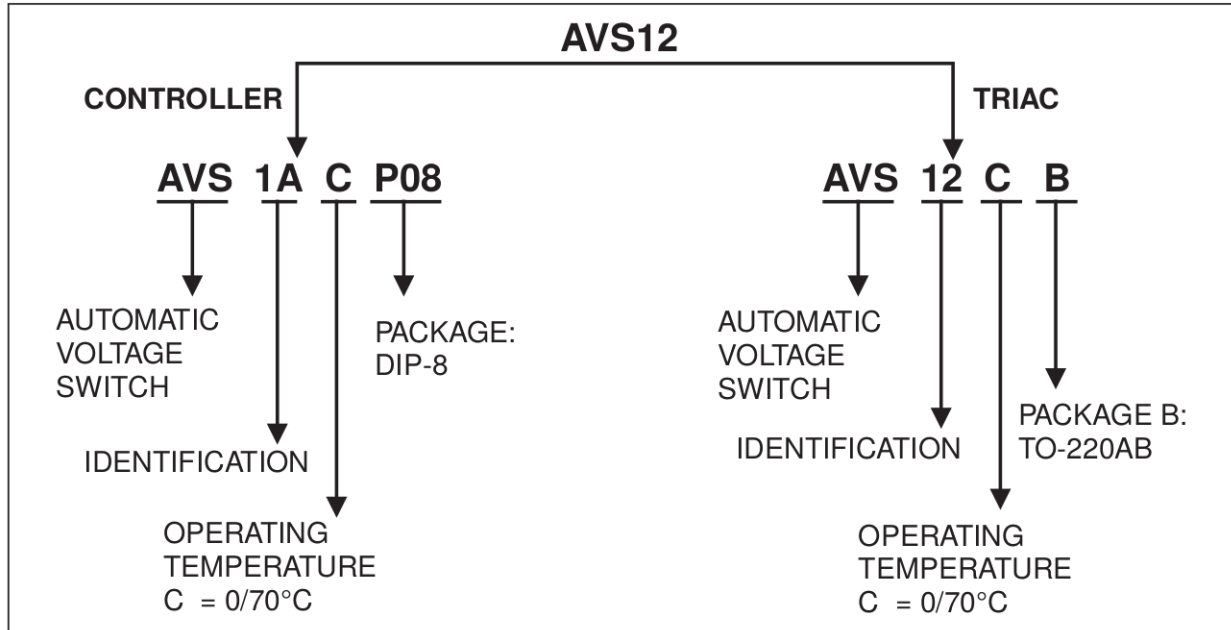

## PACKAGE MECHANICAL DATA

DIP-8 Plastic (controller)

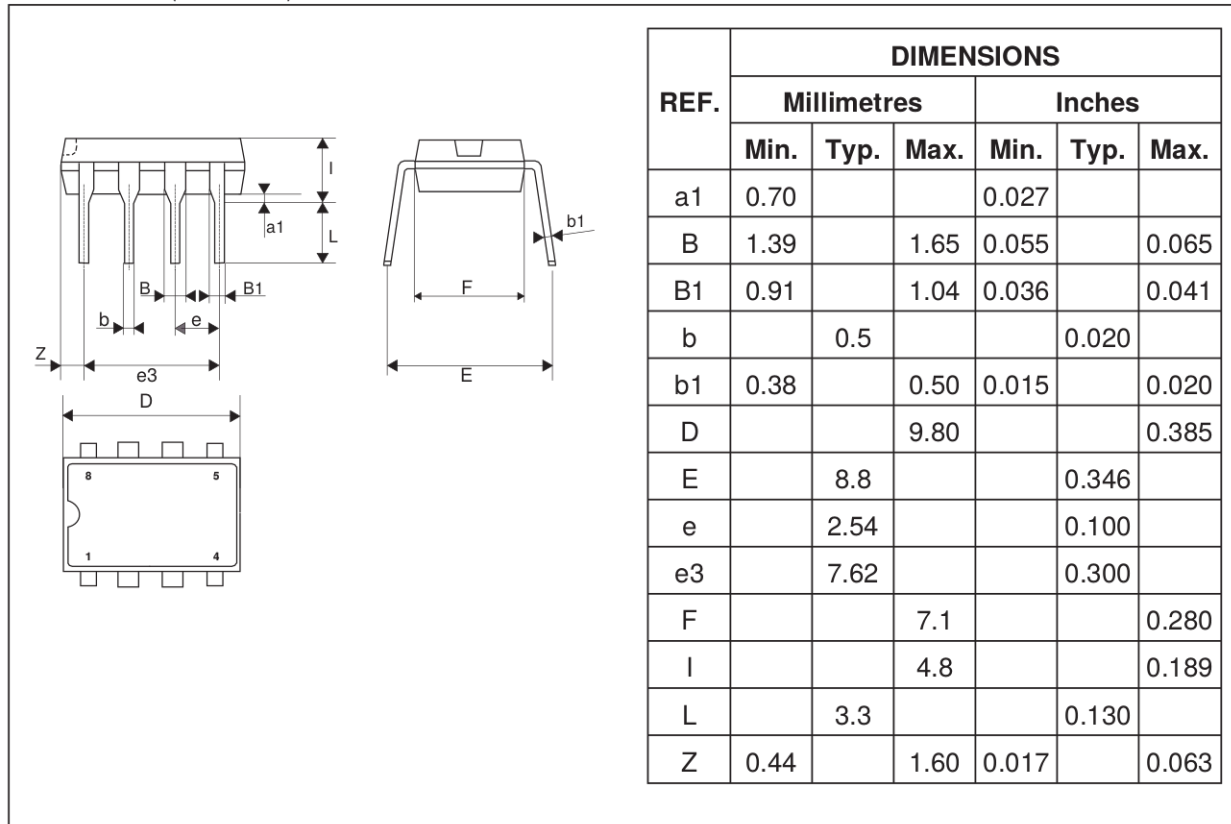

**PACKAGE MECHANICAL DATA**  
TO-220AB (Plastic) (Triac)

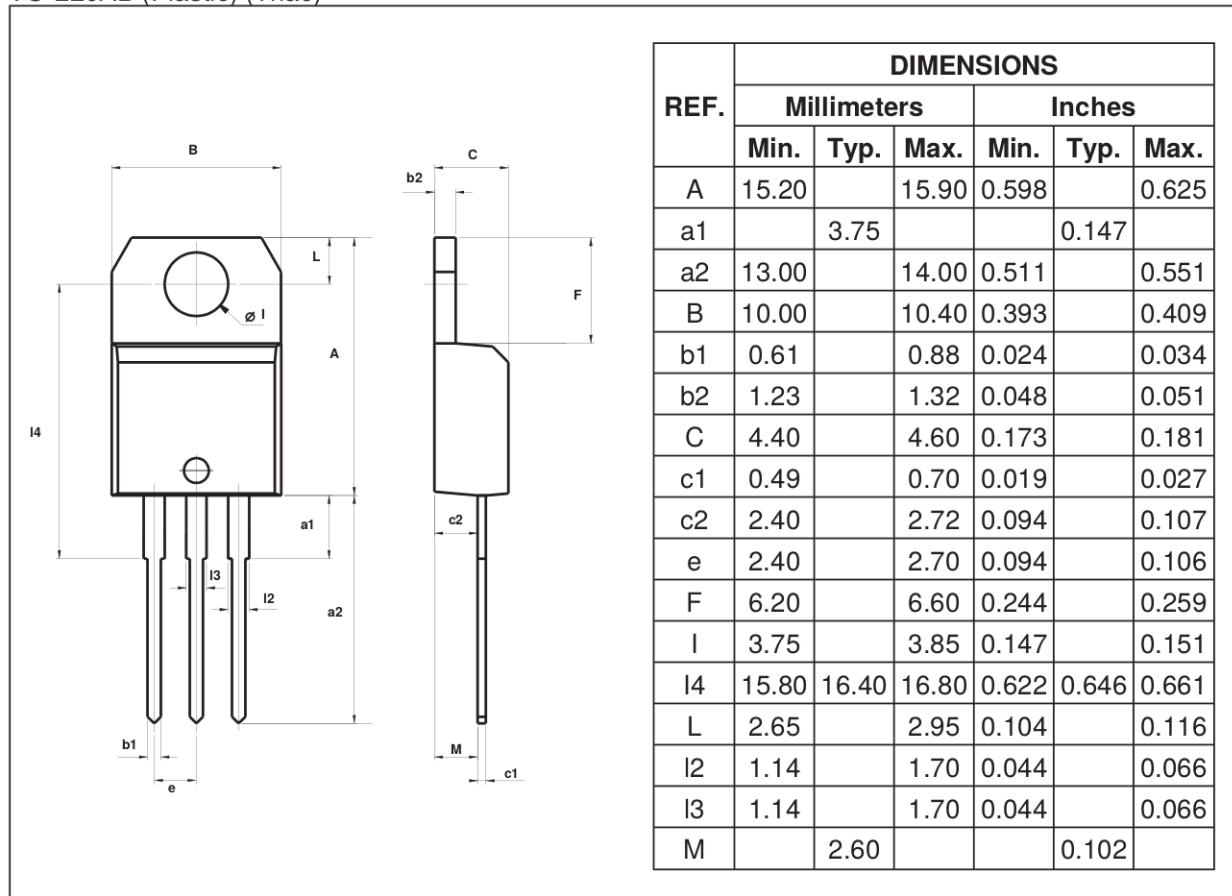

- Cooling method: C
- Recommended torque value: 0.8 m.N
- Maximum torque value: 1 m.N

**OTHER INFORMATION**

Part Number	Marking	Weight	Base Qty	Packing mode
AVS12CB	AVS12CB	2.3 g	1000	Tube
AVS1ACP08	AVS1ACP08	0.6 g	2000	Tube

Information furnished is believed to be accurate and reliable. However, STMicroelectronics assumes no responsibility for the consequences of use of such information nor for any infringement of patents or other rights of third parties which may result from its use. No license is granted by implication or otherwise under any patent or patent rights of STMicroelectronics. Specifications mentioned in this publication are subject to change without notice. This publication supersedes and replaces all information previously supplied. STMicroelectronics products are not authorized for use as critical components in life support devices or systems without express written approval of STMicroelectronics.

The ST logo is a registered trademark of STMicroelectronics

© 2002 STMicroelectronics - Printed in Italy - All rights reserved.

STMicroelectronics GROUP OF COMPANIES

Australia - Brazil - Canada - China - Finland - France - Germany  
Hong Kong - India - Israel - Italy - Japan - Malaysia - Malta - Morocco - Singapore  
Spain - Sweden - Switzerland - United Kingdom - United States.

<http://www.st.com>