

Precision 500 mA regulators

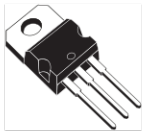

TO-220

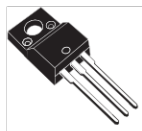

TO-220FP



DPAK

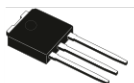

IPAK

Features

- Output current to 0.5 A
- Output voltages of 5; 6; 8; 9; 10; 12; 15; 24 V
- Thermal overload protection
- Short circuit protection
- Output transition SOA protection
- Output voltage tolerance: 2 % (AB and AC versions) or 4 % (C version)
- Guaranteed in extended temperature range

Description

The L78M series of three-terminal positive regulators is available in TO-220, TO-220FP, DPAK and IPAK packages and with several fixed output voltages, making it useful in a wide range of applications. These regulators can provide local on-card regulation, eliminating the distribution problems associated with single point regulation. Each type employs internal current limiting, thermal shutdown and safe area protection, resulting it essentially indestructible. If adequate heat sinking is provided, they can deliver over 0.5 A output current. Although designed primarily as fixed voltage regulators, these devices can be used with external components to obtain adjustable voltage and currents.

[Maturity status link](#)

L78M

1 Diagram

Figure 1. Block diagram

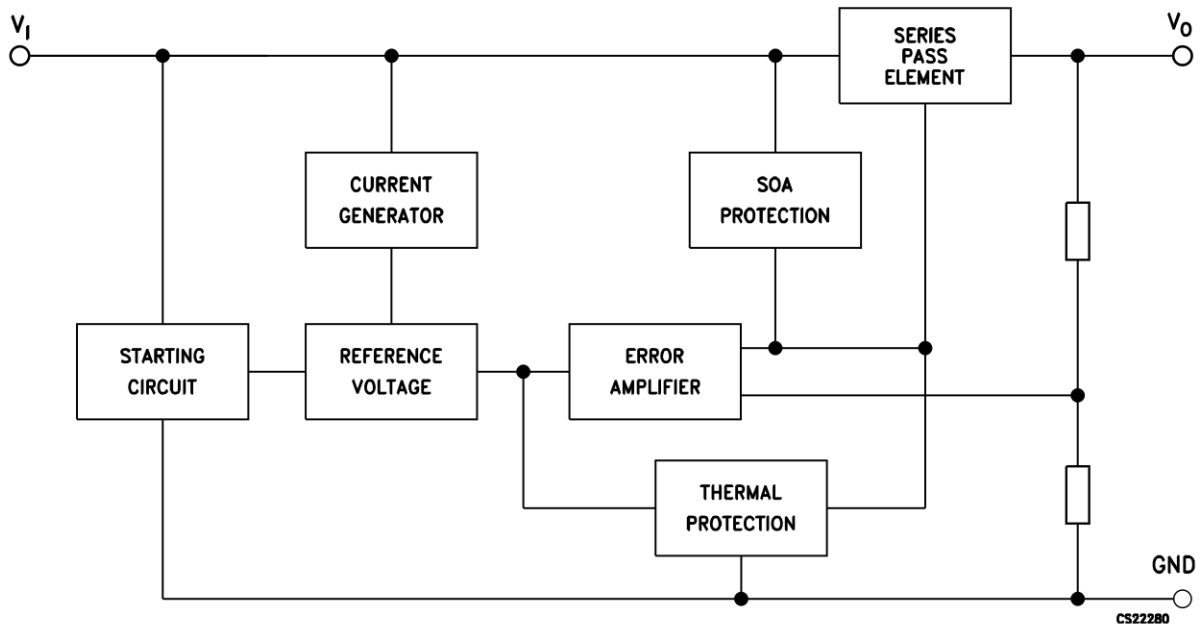

AMG080320171800MT

2 Pin configuration

Figure 2. Pin connections (top view)

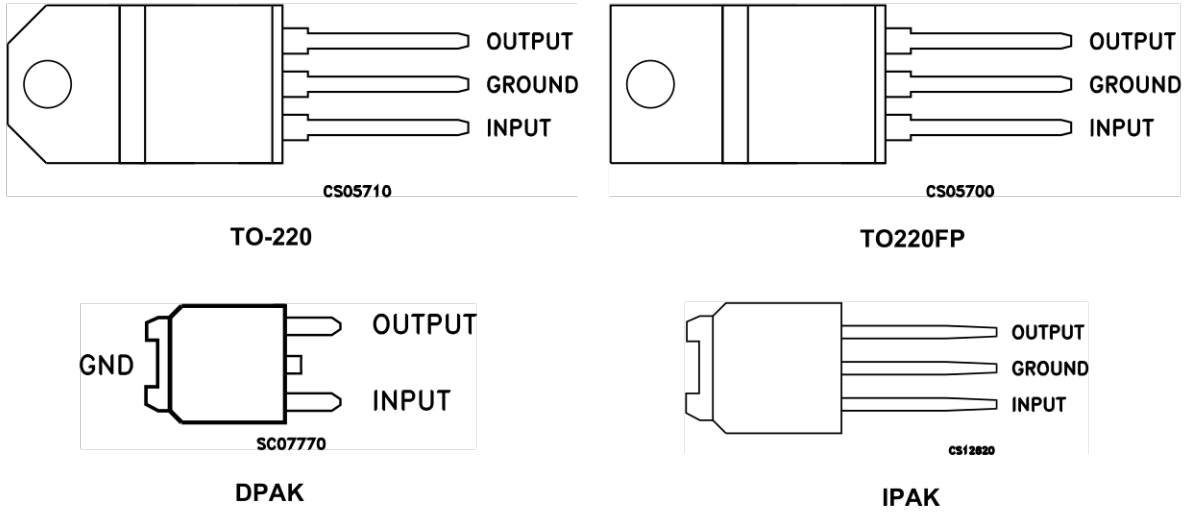

AMG080320171801MT

Figure 3. Schematic diagram

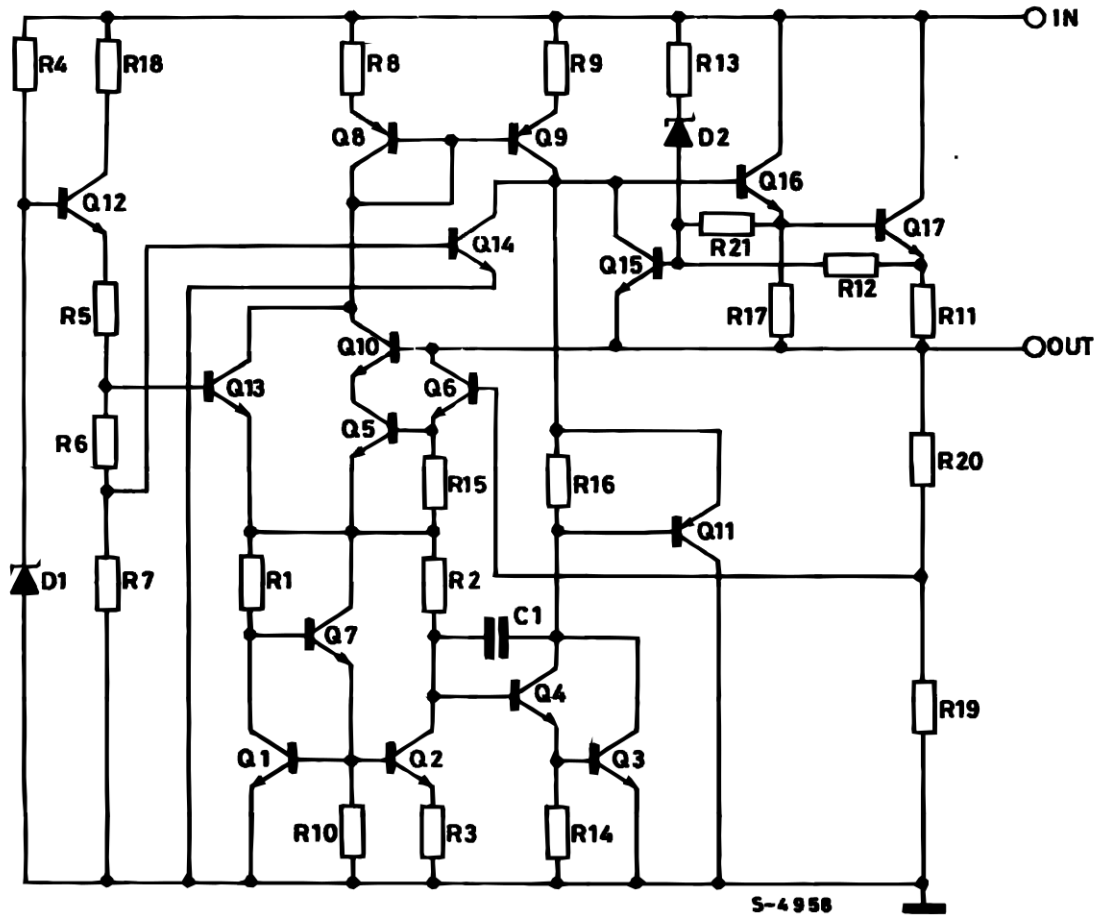

AMG080320171802MT

3 Maximum ratings

Table 1. Absolute maximum ratings

Symbol	Parameter	Value	Unit
V_I	DC input voltage	for $V_O = 5$ to 18 V	35
		for $V_O = 20, 24$ V	40
I_O	Output current	Internally limited	mA
P_D	Power dissipation	Internally limited	mW
T_{STG}	Storage temperature range	- 65 to 150	°C
T_{OP}	Operating junction temperature range	for L78MxxAC	0 to 125
		for L78MxxAB	-40 to 125
		for L78MxxC	0 to 150

Note: Absolute maximum ratings are those values beyond which damage to the device may occur. Functional operation under these condition is not implied.

Table 2. Thermal data

Symbol	Parameter	TO-220	TO-220FP	DPAK	IPAK	Unit
R_{thJC}	Thermal resistance junction-case	5	5	8	8	°C/W
R_{thJA}	Thermal resistance junction-ambient	50	60	100	100	°C/W

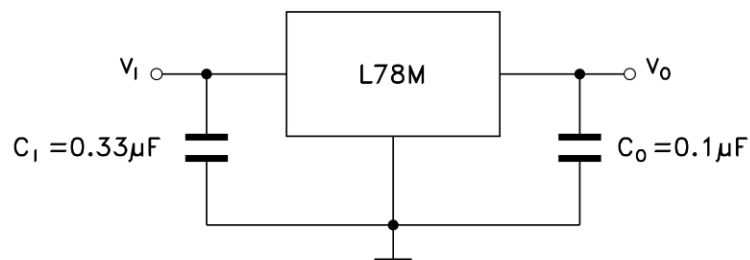
Figure 4. Application circuit

AMG080320171803MT

4 Test circuits

Figure 5. DC parameter

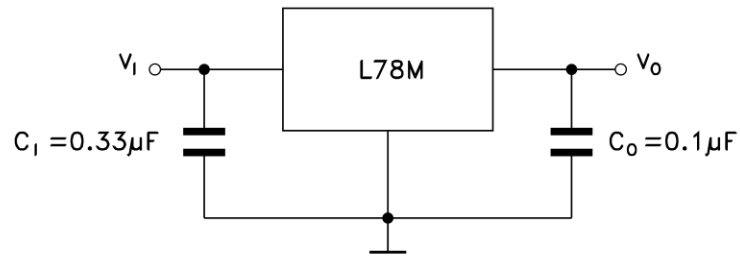

AMG080320171804MT

Figure 6. Load regulation

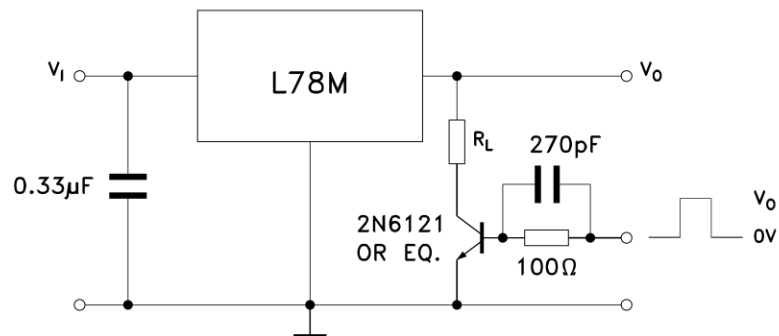

AMG080320171805MT

Figure 7. Ripple rejection

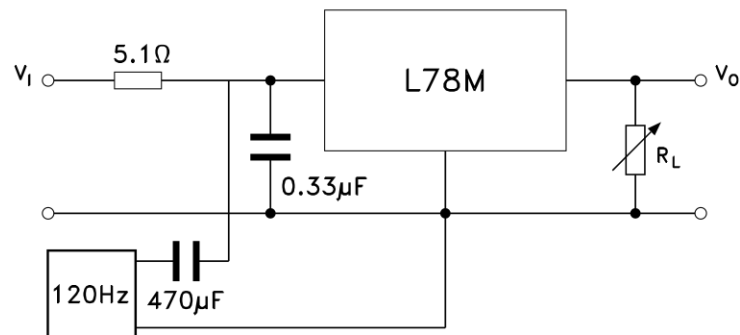

AMG080320171806MT

5 Electrical characteristics

Refer to the test circuits, $T_J = 25\text{ °C}$, $V_I = 10\text{ V}$, $I_O = 350\text{ mA}$, $C_I = 0.33\text{ }\mu\text{F}$, $C_O = 0.1\text{ }\mu\text{F}$ unless otherwise specified.

Table 3. Electrical characteristics of L78M05C

Symbol	Parameter	Test conditions	Min.	Typ.	Max.	Unit
V_O	Output voltage		4.8	5	5.2	V
V_O	Output voltage	$I_O = 5\text{ to }350\text{ mA}$, $V_I = 7\text{ to }20\text{ V}$	4.75	5	5.25	V
ΔV_O	Line regulation	$V_I = 7\text{ to }25\text{ V}$, $I_O = 200\text{ mA}$			100	mV
		$V_I = 8\text{ to }25\text{ V}$, $I_O = 200\text{ mA}$			50	
ΔV_O	Load regulation	$I_O = 5\text{ to }500\text{ mA}$, $T_J = 25\text{ °C}$			100	mV
		$I_O = 5\text{ to }200\text{ mA}$, $T_J = 25\text{ °C}$			50	
I_d	Quiescent current				6	mA
ΔI_d	Quiescent current change	$I_O = 5\text{ to }350\text{ mA}$			0.5	mA
		$I_O = 200\text{ mA}$, $V_I = 8\text{ to }25\text{ V}$			0.8	
$\Delta V_O/\Delta T$	Output voltage drift	$I_O = 5\text{ mA}$, $T_J = 0\text{ to }125\text{ °C}$		-0.5		mV/°C
SVR	Supply voltage rejection	$V_I = 8\text{ to }18\text{ V}$, $f = 120\text{ Hz}$, $I_O = 300\text{ mA}$	62			dB
eN	Output noise voltage	$B = 10\text{ Hz to }100\text{ kHz}$		40		μV
V_d	Dropout voltage			2		V
I_{sc}	Short circuit current	$V_I = 35\text{ V}$		300		mA

Refer to the test circuits, $V_I = 10\text{ V}$, $I_O = 350\text{ mA}$, $C_I = 0.33\text{ }\mu\text{F}$, $C_O = 0.1\text{ }\mu\text{F}$, $T_J = -40\text{ to }125\text{ }^\circ\text{C}$ (AB), $T_J = 0\text{ to }125\text{ }^\circ\text{C}$ (AC) unless otherwise specified.

Table 4. Electrical characteristics of L78M05A

Symbol	Parameter	Test conditions	Min.	Typ.	Max.	Unit
V_O	Output voltage	$T_J = 25\text{ }^\circ\text{C}$	4.9	5	5.1	V
V_O	Output voltage	$I_O = 5\text{ to }350\text{ mA}$, $V_I = 7\text{ to }20\text{ V}$	4.8	5	5.2	V
ΔV_O	Line regulation	$V_I = 7\text{ to }25\text{ V}$, $I_O = 200\text{ mA}$, $T_J = 25\text{ }^\circ\text{C}$			100	mV
		$V_I = 8\text{ to }25\text{ V}$, $I_O = 200\text{ mA}$, $T_J = 25\text{ }^\circ\text{C}$			50	
ΔV_O	Load regulation	$I_O = 5\text{ to }500\text{ mA}$, $T_J = 25\text{ }^\circ\text{C}$			100	mV
		$I_O = 5\text{ to }200\text{ mA}$, $T_J = 25\text{ }^\circ\text{C}$			50	
I_d	Quiescent current	$T_J = 25\text{ }^\circ\text{C}$			6	mA
ΔI_d	Quiescent current change	$I_O = 5\text{ to }350\text{ mA}$			0.5	mA
		$I_O = 200\text{ mA}$, $V_I = 8\text{ to }25\text{ V}$			0.8	
$\Delta V_O/\Delta T$	Output voltage drift	$I_O = 5\text{ mA}$		-0.5		mV/°C
SVR	Supply voltage rejection	$V_I = 8\text{ to }18\text{ V}$, $f = 120\text{ Hz}$, $I_O = 300\text{ mA}$, $T_J = 25\text{ }^\circ\text{C}$	62			dB
eN	Output noise voltage	$B = 10\text{ Hz to }100\text{ kHz}$, $T_J = 25\text{ }^\circ\text{C}$		40		μV
V_d	Dropout voltage	$T_J = 25\text{ }^\circ\text{C}$		2		V
I_{sc}	Short circuit current	$T_J = 25\text{ }^\circ\text{C}$, $V_I = 35\text{ V}$		300		mA
I_{scp}	Short circuit peak current	$T_J = 25\text{ }^\circ\text{C}$		700		mA

Refer to the test circuits, $T_J = 25\text{ }^\circ\text{C}$, $V_I = 11\text{ V}$, $I_O = 350\text{ mA}$, $C_I = 0.33\text{ }\mu\text{F}$, $C_O = 0.1\text{ }\mu\text{F}$ unless otherwise specified.

Table 5. Electrical characteristics of L78M06C

Symbol	Parameter	Test conditions	Min.	Typ.	Max.	Unit
V_O	Output voltage		5.75	6	6.25	V
V_O	Output voltage	$I_O = 5\text{ to }350\text{ mA}$, $V_I = 8\text{ to }21\text{ V}$	5.7	6	6.3	V
ΔV_O	Line regulation	$V_I = 8\text{ to }25\text{ V}$, $I_O = 200\text{ mA}$			100	mV
		$V_I = 9\text{ to }25\text{ V}$, $I_O = 200\text{ mA}$			50	
ΔV_O	Load regulation	$I_O = 5\text{ to }500\text{ mA}$, $T_J = 25\text{ }^\circ\text{C}$			120	mV
		$I_O = 5\text{ to }200\text{ mA}$, $T_J = 25\text{ }^\circ\text{C}$			60	
I_d	Quiescent current				6	mA
ΔI_d	Quiescent current change	$I_O = 5\text{ to }350\text{ mA}$			0.5	mA
		$I_O = 200\text{ mA}$, $V_I = 9\text{ to }25\text{ V}$			0.8	
$\Delta V_O/\Delta T$	Output voltage drift	$I_O = 5\text{ mA}$, $T_J = 0\text{ to }125\text{ }^\circ\text{C}$		-0.5		mV/°C
SVR	Supply voltage rejection	$V_I = 9\text{ to }19\text{ V}$, $f = 120\text{ Hz}$, $I_O = 300\text{ mA}$	59			dB
eN	Output noise voltage	$B = 10\text{ Hz to }100\text{ kHz}$		45		μV
V_d	Dropout voltage			2		V
I_{sc}	Short circuit current	$V_I = 35\text{ V}$		270		mA

Refer to the test circuits, $V_I = 11\text{ V}$, $I_O = 350\text{ mA}$, $C_I = 0.33\text{ }\mu\text{F}$, $C_O = 0.1\text{ }\mu\text{F}$, $T_J = -40\text{ to }125\text{ }^\circ\text{C}$ (AB), $T_J = 0\text{ to }125\text{ }^\circ\text{C}$ (AC) unless otherwise specified.

Table 6. Electrical characteristics of L78M06A

Symbol	Parameter	Test conditions	Min.	Typ.	Max.	Unit
V_O	Output voltage	$T_J = 25\text{ }^\circ\text{C}$	5.88	6	6.12	V
V_O	Output voltage	$I_O = 5\text{ to }350\text{ mA}$, $V_I = 8\text{ to }21\text{ V}$	5.75	6	6.3	V
DV_O	Line regulation	$V_I = 8\text{ to }25\text{ V}$, $I_O = 200\text{ mA}$, $T_J = 25\text{ }^\circ\text{C}$			100	mV
		$V_I = 9\text{ to }25\text{ V}$, $I_O = 200\text{ mA}$, $T_J = 25\text{ }^\circ\text{C}$			30	
ΔV_O	Load regulation	$I_O = 5\text{ to }500\text{ mA}$, $T_J = 25\text{ }^\circ\text{C}$			120	mV
		$I_O = 5\text{ to }200\text{ mA}$, $T_J = 25\text{ }^\circ\text{C}$			60	
I_d	Quiescent current	$T_J = 25\text{ }^\circ\text{C}$			6	mA
ΔI_d	Quiescent current change	$I_O = 5\text{ to }350\text{ mA}$			0.5	mA
		$I_O = 200\text{ mA}$, $V_I = 9\text{ to }25\text{ V}$			0.8	
$\Delta V_O/\Delta T$	Output voltage drift	$I_O = 5\text{ mA}$		-0.5		mV/°C
SVR	Supply voltage rejection	$V_I = 9\text{ to }19\text{ V}$, $f = 120\text{ Hz}$, $I_O = 300\text{ mA}$, $T_J = 25\text{ }^\circ\text{C}$	59			dB
eN	Output noise voltage	$B = 10\text{ Hz to }100\text{ kHz}$		45		μV
V_d	Dropout voltage	$T_J = 25\text{ }^\circ\text{C}$		2		V
I_{sc}	Short circuit current	$T_J = 25\text{ }^\circ\text{C}$, $V_I = 35\text{ V}$		270		mA
I_{scp}	Short circuit peak current	$T_J = 25\text{ }^\circ\text{C}$		700		mA

Refer to the test circuits, $T_J = 25\text{ }^\circ\text{C}$, $V_I = 14\text{ V}$, $I_O = 350\text{ mA}$, $C_I = 0.33\text{ }\mu\text{F}$, $C_O = 0.1\text{ }\mu\text{F}$ unless otherwise specified.

Table 7. Electrical characteristics of L78M08C

Symbol	Parameter	Test conditions	Min.	Typ.	Max.	Unit
V_O	Output voltage		7.7	8	8.3	V
V_O	Output voltage	$I_O = 5\text{ to }350\text{ mA}$, $V_I = 10.5\text{ to }23\text{ V}$	7.6	8	8.4	V
ΔV_O	Line regulation	$V_I = 10.5\text{ to }25\text{ V}$, $I_O = 200\text{ mA}$			100	mV
		$V_I = 11\text{ to }25\text{ V}$, $I_O = 200\text{ mA}$			50	
ΔV_O	Load regulation	$I_O = 5\text{ to }500\text{ mA}$, $T_J = 25\text{ }^\circ\text{C}$			160	mV
		$I_O = 5\text{ to }200\text{ mA}$, $T_J = 25\text{ }^\circ\text{C}$			80	
I_d	Quiescent current				6	mA
ΔI_d	Quiescent current change	$I_O = 5\text{ to }350\text{ mA}$			0.5	mA
		$I_O = 200\text{ mA}$, $V_I = 10.5\text{ to }25\text{ V}$			0.8	
$\Delta V_O/\Delta T$	Output voltage drift	$I_O = 5\text{ mA}$, $T_J = 0\text{ to }125\text{ }^\circ\text{C}$		-0.5		mV/°C
SVR	Supply voltage rejection	$V_I = 11.5\text{ to }21.5\text{ V}$, $f = 120\text{ Hz}$, $I_O = 300\text{ mA}$	56			dB
eN	Output noise voltage	$B = 10\text{ Hz to }100\text{ kHz}$		52		μV
V_d	Dropout voltage			2		V
I_{sc}	Short circuit current	$V_I = 35\text{ V}$		250		mA

Refer to the test circuits, $V_I = 14\text{ V}$, $I_O = 350\text{ mA}$, $C_I = 0.33\text{ }\mu\text{F}$, $C_O = 0.1\text{ }\mu\text{F}$, $T_J = -40\text{ to }125\text{ }^\circ\text{C}$ (AB), $T_J = 0\text{ to }125\text{ }^\circ\text{C}$ (AC) unless otherwise specified.

Table 8. Electrical characteristics of L78M08A

Symbol	Parameter	Test conditions	Min.	Typ.	Max.	Unit
V_O	Output voltage	$T_J = 25\text{ }^\circ\text{C}$	7.84	8	8.16	V
V_O	Output voltage	$I_O = 5\text{ to }350\text{ mA}$, $V_I = 10.5\text{ to }23\text{ V}$	7.7	8	8.3	V
ΔV_O	Line regulation	$V_I = 10.5\text{ to }25\text{ V}$, $I_O = 200\text{ mA}$, $T_J = 25\text{ }^\circ\text{C}$			100	mV
		$V_I = 11\text{ to }25\text{ V}$, $I_O = 200\text{ mA}$, $T_J = 25\text{ }^\circ\text{C}$			30	
ΔV_O	Load regulation	$I_O = 5\text{ to }500\text{ mA}$, $T_J = 25\text{ }^\circ\text{C}$			160	mV
		$I_O = 5\text{ to }200\text{ mA}$, $T_J = 25\text{ }^\circ\text{C}$			80	
I_d	Quiescent current	$T_J = 25\text{ }^\circ\text{C}$			6	mA
ΔI_d	Quiescent current change	$I_O = 5\text{ to }350\text{ mA}$			0.5	mA
		$I_O = 200\text{ mA}$, $V_I = 10.5\text{ to }25\text{ V}$			0.8	
$\Delta V_O/\Delta T$	Output voltage drift	$I_O = 5\text{ mA}$		-0.5		mV/°C
SVR	Supply voltage rejection	$V_I = 11.5\text{ to }21.5\text{ V}$, $f = 120\text{ Hz}$, $I_O = 300\text{ mA}$, $T_J = 25\text{ }^\circ\text{C}$	56			dB
eN	Output noise voltage	$B = 10\text{ Hz to }100\text{ kHz}$, $T_J = 25\text{ }^\circ\text{C}$		52		μV
V_d	Dropout voltage	$T_J = 25\text{ }^\circ\text{C}$		2		V
I_{sc}	Short circuit current	$T_J = 25\text{ }^\circ\text{C}$, $V_I = 35\text{ V}$		250		mA
I_{scp}	Short circuit peak current	$T_J = 25\text{ }^\circ\text{C}$		700		mA

Refer to the test circuits, $T_J = 25\text{ }^\circ\text{C}$, $V_I = 15\text{ V}$, $I_O = 350\text{ mA}$, $C_I = 0.33\text{ }\mu\text{F}$, $C_O = 0.1\text{ }\mu\text{F}$ unless otherwise specified.

Table 9. Electrical characteristics of L78M09C

Symbol	Parameter	Test conditions	Min.	Typ.	Max.	Unit
V_O	Output voltage		8.65	9	9.35	V
V_O	Output voltage	$I_O = 5\text{ to }350\text{ mA}$, $V_I = 11.5\text{ to }24\text{ V}$	8.55	9	9.45	V
ΔV_O	Line regulation	$V_I = 11.5\text{ to }25\text{ V}$, $I_O = 200\text{ mA}$			100	mV
		$V_I = 12\text{ to }25\text{ V}$, $I_O = 200\text{ mA}$			50	
ΔV_O	Load regulation	$I_O = 5\text{ to }500\text{ mA}$, $T_J = 25\text{ }^\circ\text{C}$			180	mV
		$I_O = 5\text{ to }200\text{ mA}$, $T_J = 25\text{ }^\circ\text{C}$			90	
I_d	Quiescent current				6	mA
ΔI_d	Quiescent current change	$I_O = 5\text{ to }350\text{ mA}$			0.5	mA
		$I_O = 200\text{ mA}$, $V_I = 11.5\text{ to }25\text{ V}$			0.8	
$\Delta V_O/\Delta T$	Output voltage drift	$I_O = 5\text{ mA}$, $T_J = 0\text{ to }125\text{ }^\circ\text{C}$		-0.5		mV/°C
SVR	Supply voltage rejection	$V_I = 12.5\text{ to }23\text{ V}$, $f = 120\text{ Hz}$, $I_O = 300\text{ mA}$	56			dB
eN	Output noise voltage	$B = 10\text{ Hz to }100\text{ kHz}$		58		μV
V_d	Dropout voltage			2		V
I_{sc}	Short circuit current	$V_I = 35\text{ V}$		250		mA

Refer to the test circuits, $V_I = 15\text{ V}$, $I_O = 350\text{ mA}$, $C_I = 0.33\text{ }\mu\text{F}$, $C_O = 0.1\text{ }\mu\text{F}$, $T_J = -40\text{ to }125\text{ }^\circ\text{C}$ (AB), $T_J = 0\text{ to }125\text{ }^\circ\text{C}$ (AC) unless otherwise specified.

Table 10. Electrical characteristics of L78M09A

Symbol	Parameter	Test conditions	Min.	Typ.	Max.	Unit
V_O	Output voltage	$T_J = 25\text{ }^\circ\text{C}$	8.82	9	9.18	V
V_O	Output voltage	$I_O = 5\text{ to }350\text{ mA}$, $V_I = 11.5\text{ to }24\text{ V}$	8.64	9	9.36	V
ΔV_O	Line regulation	$V_I = 11.5\text{ to }25\text{ V}$, $I_O = 200\text{ mA}$, $T_J = 25\text{ }^\circ\text{C}$			100	mV
		$V_I = 12\text{ to }25\text{ V}$, $I_O = 200\text{ mA}$, $T_J = 25\text{ }^\circ\text{C}$			30	
ΔV_O	Load regulation	$I_O = 5\text{ to }500\text{ mA}$, $T_J = 25\text{ }^\circ\text{C}$			180	mV
		$I_O = 5\text{ to }200\text{ mA}$, $T_J = 25\text{ }^\circ\text{C}$			90	
I_d	Quiescent current	$T_J = 25\text{ }^\circ\text{C}$			6	mA
ΔI_d	Quiescent current change	$I_O = 5\text{ to }350\text{ mA}$			0.5	mA
		$I_O = 200\text{ mA}$, $V_I = 11.5\text{ to }25\text{ V}$			0.8	
$\Delta V_O/\Delta T$	Output voltage drift	$I_O = 5\text{ mA}$		-0.5		mV/ $^\circ\text{C}$
SVR	Supply voltage rejection	$V_I = 12.5\text{ to }23\text{ V}$, $f = 120\text{ Hz}$, $I_O = 300\text{ mA}$, $T_J = 25\text{ }^\circ\text{C}$	56			dB
eN	Output noise voltage	$B = 10\text{ Hz to }100\text{ kHz}$, $T_J = 25\text{ }^\circ\text{C}$		52		μV
V_d	Dropout voltage	$T_J = 25\text{ }^\circ\text{C}$		2		V
I_{sc}	Short circuit current	$V_I = 35\text{ V}$, $T_J = 25\text{ }^\circ\text{C}$		250		mA
I_{scp}	Short circuit peak current	$T_J = 25\text{ }^\circ\text{C}$		700		mA

Refer to the test circuits, $V_I = 16\text{ V}$, $I_O = 350\text{ mA}$, $C_I = 0.33\text{ }\mu\text{F}$, $C_O = 0.1\text{ }\mu\text{F}$, $T_J = -40\text{ to }125\text{ }^\circ\text{C}$ (AB), $T_J = 0\text{ to }125\text{ }^\circ\text{C}$ (AC) unless otherwise specified.

Table 11. Electrical characteristics of L78M10A

Symbol	Parameter	Test conditions	Min.	Typ.	Max.	Unit
V_O	Output voltage	$T_J = 25\text{ }^\circ\text{C}$	9.8	10	10.2	V
V_O	Output voltage	$I_O = 5\text{ to }350\text{ mA}$, $V_I = 12.5\text{ to }25\text{ V}$	9.6	10	10.4	V
ΔV_O	Line regulation	$V_I = 12.5\text{ to }30\text{ V}$, $I_O = 200\text{ mA}$, $T_J = 25\text{ }^\circ\text{C}$			100	mV
		$V_I = 13\text{ to }30\text{ V}$, $I_O = 200\text{ mA}$, $T_J = 25\text{ }^\circ\text{C}$			30	
ΔV_O	Load regulation	$I_O = 5\text{ to }500\text{ mA}$, $T_J = 25\text{ }^\circ\text{C}$			200	mV
		$I_O = 5\text{ to }200\text{ mA}$, $T_J = 25\text{ }^\circ\text{C}$			100	
I_d	Quiescent current	$T_J = 25\text{ }^\circ\text{C}$			6	mA
ΔI_d	Quiescent current change	$I_O = 5\text{ to }350\text{ mA}$			0.5	mA
		$I_O = 200\text{ mA}$, $V_I = 12.5\text{ to }30\text{ V}$			0.8	
$\Delta V_O/\Delta T$	Output voltage drift	$I_O = 5\text{ mA}$		-0.5		mV/ $^\circ\text{C}$
SVR	Supply voltage rejection	$V_I = 13.5\text{ to }24\text{ V}$, $f = 120\text{ Hz}$, $I_O = 300\text{ mA}$, $T_J = 25\text{ }^\circ\text{C}$	56			dB
eN	Output noise voltage	$B = 10\text{ Hz to }100\text{ kHz}$, $T_J = 25\text{ }^\circ\text{C}$		64		μV
V_d	Dropout voltage	$T_J = 25\text{ }^\circ\text{C}$		2		V

Symbol	Parameter	Test conditions	Min.	Typ.	Max.	Unit
I_{sc}	Short circuit current	$V_I = 35\text{ V}, T_J = 25\text{ }^\circ\text{C}$		245		mA
I_{scp}	Short circuit peak current	$T_J = 25\text{ }^\circ\text{C}$		700		mA

Refer to the test circuits, $T_J = 25\text{ }^\circ\text{C}$, $V_I = 19\text{ V}$, $I_O = 350\text{ mA}$, $C_I = 0.33\text{ }\mu\text{F}$, $C_O = 0.1\text{ }\mu\text{F}$ unless otherwise specified.

Table 12. Electrical characteristics of L78M12C

Symbol	Parameter	Test conditions	Min.	Typ.	Max.	Unit
V_O	Output voltage		11.5	12	12.5	V
V_O	Output voltage	$I_O = 5\text{ to }350\text{ mA}, V_I = 14.5\text{ to }27\text{ V}$	11.4	12	12.6	V
ΔV_O	Line regulation	$V_I = 14.5\text{ to }30\text{ V}, I_O = 200\text{ mA}$			100	mV
		$V_I = 16\text{ to }30\text{ V}, I_O = 200\text{ mA}$			50	
ΔV_O	Load regulation	$I_O = 5\text{ to }500\text{ mA}, T_J = 25\text{ }^\circ\text{C}$			240	mV
		$I_O = 5\text{ to }200\text{ mA}, T_J = 25\text{ }^\circ\text{C}$			120	
I_d	Quiescent current				6	mA
ΔI_d	Quiescent current change	$I_O = 5\text{ to }350\text{ mA}$			0.5	mA
		$I_O = 200\text{ mA}, V_I = 14.5\text{ to }30\text{ V}$			0.8	
$\Delta V_O/\Delta T$	Output voltage drift	$I_O = 5\text{ mA}, T_J = 0\text{ to }125\text{ }^\circ\text{C}$		-1		mV/°C
SVR	Supply voltage rejection	$V_I = 15\text{ to }25\text{ V}, f = 120\text{ Hz}, I_O = 300\text{ mA}$	55			dB
eN	Output noise voltage	$B = 10\text{ Hz to }100\text{ kHz}$		75		μV
V_d	Dropout voltage			2		V
I_{sc}	Short circuit current	$V_I = 35\text{ V}$		240		mA

Refer to the test circuits, $V_I = 19\text{ V}$, $I_O = 350\text{ mA}$, $C_I = 0.33\text{ }\mu\text{F}$, $C_O = 0.1\text{ }\mu\text{F}$, $T_J = -40\text{ to }125\text{ }^\circ\text{C}$ (AB), $T_J = 0\text{ to }125\text{ }^\circ\text{C}$ (AC) unless otherwise specified.

Table 13. Electrical characteristics of L78M12A

Symbol	Parameter	Test conditions	Min.	Typ.	Max.	Unit
V_O	Output voltage	$T_J = 25\text{ }^\circ\text{C}$	11.75	12	12.25	V
V_O	Output voltage	$I_O = 5\text{ to }350\text{ mA}, V_I = 14.5\text{ to }27\text{ V}$	11.5	12	12.5	V
ΔV_O	Line regulation	$V_I = 14.5\text{ to }30\text{ V}, I_O = 200\text{ mA}, T_J = 25\text{ }^\circ\text{C}$			100	mV
		$V_I = 16\text{ to }30\text{ V}, I_O = 200\text{ mA}, T_J = 25\text{ }^\circ\text{C}$			30	
ΔV_O	Load regulation	$I_O = 5\text{ to }500\text{ mA}, T_J = 25\text{ }^\circ\text{C}$			240	mV
		$I_O = 5\text{ to }200\text{ mA}, T_J = 25\text{ }^\circ\text{C}$			120	
I_d	Quiescent current	$T_J = 25\text{ }^\circ\text{C}$			6	mA
ΔI_d	Quiescent current change	$I_O = 5\text{ to }350\text{ mA}$			0.5	mA
		$I_O = 200\text{ mA}, V_I = 14.5\text{ to }30\text{ V}$			0.8	
$\Delta V_O/\Delta T$	Output voltage drift	$I_O = 5\text{ mA}$		-1		mV/°C
SVR	Supply voltage rejection	$V_I = 15\text{ to }25\text{ V}, f = 120\text{ Hz}, I_O = 300\text{ mA}, T_J = 25\text{ }^\circ\text{C}$	55			dB

Symbol	Parameter	Test conditions	Min.	Typ.	Max.	Unit
eN	Output noise voltage	B = 10 Hz to 100 kHz, T _J = 25 °C		75		μV
V _d	Dropout voltage	T _J = 25 °C		2		V
I _{sc}	Short circuit current	V _I = 35 V, T _J = 25 °C		240		mA
I _{scp}	Short circuit peak current	T _J = 25 °C		700		mA

Refer to the test circuits, T_J = 25 °C, V_I = 23 V, I_O = 350 mA, C_I = 0.33 μF, C_O = 0.1 μF unless otherwise specified.

Table 14. Electrical characteristics of L78M15C

Symbol	Parameter	Test conditions	Min.	Typ.	Max.	Unit
V _O	Output voltage		14.4	15	15.6	V
V _O	Output voltage	I _O = 5 to 350 mA, V _I = 17.5 to 30 V	14.25	15	15.75	V
ΔV _O	Line regulation	V _I = 17.5 to 30 V, I _O = 200 mA			100	mV
		V _I = 20 to 30 V, I _O = 200 mA			50	
ΔV _O	Load regulation	I _O = 5 to 500 mA, T _J = 25 °C			300	mV
		I _O = 5 to 200 mA, T _J = 25 °C			150	
I _d	Quiescent current				6	mA
ΔI _d	Quiescent current change	I _O = 5 to 350 mA			0.5	mA
		I _O = 200 mA, V _I = 17.5 to 30 V			0.8	
ΔV _O /ΔT	Output voltage drift	I _O = 5 mA, T _J = 0 to 125 °C		-1		mV/°C
SVR	Supply voltage rejection	V _I = 18.5 to 28.5 V, f = 120 Hz, I _O = 300 mA	54			dB
eN	Output noise voltage	B = 10 Hz to 100 kHz		90		μV
V _d	Dropout voltage			2		V
I _{sc}	Short circuit current	V _I = 35 V		240		mA

Refer to the test circuits, V_I = 23 V, I_O = 350 mA, C_I = 0.33 μF, C_O = 0.1 μF, T_J = -40 to 125 °C (AB), T_J = 0 to 125 °C (AC) unless otherwise specified.

Table 15. Electrical characteristics of L78M15A

Symbol	Parameter	Test conditions	Min.	Typ.	Max.	Unit
V _O	Output voltage	T _J = 25 °C	14.7	15	15.3	V
V _O	Output voltage	I _O = 5 to 350 mA, V _I = 17.5 to 30 V	14.4	15	15.6	V
ΔV _O	Line regulation	V _I = 17.5 to 30 V, I _O = 200 mA, T _J = 25 °C			100	mV
		V _I = 20 to 30 V, I _O = 200 mA, T _J = 25 °C			30	
ΔV _O	Load regulation	I _O = 5 to 500 mA, T _J = 25 °C			300	mV
		I _O = 5 to 200 mA, T _J = 25 °C			150	
I _d	Quiescent current	T _J = 25 °C			6	mA
ΔI _d	Quiescent current change	I _O = 5 to 350 mA			0.5	mA
		I _O = 200 mA, V _I = 17.5 to 30 V			0.8	

Symbol	Parameter	Test conditions	Min.	Typ.	Max.	Unit
$\Delta V_O/\Delta T$	Output voltage drift	$I_O = 5 \text{ mA}$		-1		mV/°C
SVR	Supply voltage rejection	$V_I = 18.5 \text{ to } 28.5 \text{ V}$, $f = 120 \text{ Hz}$, $I_O = 300 \text{ mA}$, $T_J = 25 \text{ °C}$	54			dB
eN	Output noise voltage	$B = 10 \text{ Hz to } 100 \text{ kHz}$, $T_J = 25 \text{ °C}$		90		μV
V_d	Dropout voltage	$T_J = 25 \text{ °C}$		2		V
I_{sc}	Short circuit current	$V_I = 35 \text{ V}$, $T_J = 25 \text{ °C}$		240		mA
I_{scp}	Short circuit peak current	$T_J = 25 \text{ °C}$		700		mA

Refer to the test circuits, $T_J = 25 \text{ °C}$, $V_I = 33 \text{ V}$, $I_O = 350 \text{ mA}$, $C_I = 0.33 \text{ }\mu\text{F}$, $C_O = 0.1 \text{ }\mu\text{F}$ unless otherwise specified.

Table 16. Electrical characteristics of L78M24C

Symbol	Parameter	Test conditions	Min.	Typ.	Max.	Unit
V_O	Output voltage		23	24	25	V
V_O	Output voltage	$I_O = 5 \text{ to } 350 \text{ mA}$, $V_I = 27 \text{ to } 38 \text{ V}$	22.8	24	25.2	V
ΔV_O	Line regulation	$V_I = 27 \text{ to } 38 \text{ V}$, $I_O = 200 \text{ mA}$			100	mV
		$V_I = 28 \text{ to } 38 \text{ V}$, $I_O = 200 \text{ mA}$			50	
ΔV_O	Load regulation	$I_O = 5 \text{ to } 500 \text{ mA}$, $T_J = 25 \text{ °C}$			480	mV
		$I_O = 5 \text{ to } 200 \text{ mA}$, $T_J = 25 \text{ °C}$			240	
I_d	Quiescent current				6	mA
ΔI_d	Quiescent current change	$I_O = 5 \text{ to } 350 \text{ mA}$			0.5	mA
		$I_O = 200 \text{ mA}$, $V_I = 27 \text{ to } 38 \text{ V}$			0.8	
$\Delta V_O/\Delta T$	Output voltage drift	$I_O = 5 \text{ mA}$, $T_J = 0 \text{ to } 125 \text{ °C}$		-1.2		mV/°C
SVR	Supply voltage rejection	$V_I = 28 \text{ to } 38 \text{ V}$, $f = 120 \text{ Hz}$, $I_O = 300 \text{ mA}$	50			dB
eN	Output noise voltage	$B = 10 \text{ Hz to } 100 \text{ kHz}$		170		μV
V_d	Dropout voltage			2		V
I_{sc}	Short circuit current	$V_I = 35 \text{ V}$		240		mA

Refer to the test circuits, $V_I = 33 \text{ V}$, $I_O = 350 \text{ mA}$, $C_I = 0.33 \text{ }\mu\text{F}$, $C_O = 0.1 \text{ }\mu\text{F}$, $T_J = -40 \text{ to } 125 \text{ °C}$ (AB), $T_J = 0 \text{ to } 125 \text{ °C}$ (AC) unless otherwise specified.

Table 17. Electrical characteristics of L78M24A

Symbol	Parameter	Test conditions	Min.	Typ.	Max.	Unit
V_O	Output voltage	$T_J = 25 \text{ °C}$	23.5	24	24.5	V
V_O	Output voltage	$I_O = 5 \text{ to } 350 \text{ mA}$, $V_I = 27 \text{ to } 38 \text{ V}$	23	24	25	V
ΔV_O	Line regulation	$V_I = 27 \text{ to } 38 \text{ V}$, $I_O = 200 \text{ mA}$, $T_J = 25 \text{ °C}$			100	mV
		$V_I = 28 \text{ to } 38 \text{ V}$, $I_O = 200 \text{ mA}$, $T_J = 25 \text{ °C}$			30	
ΔV_O	Load regulation	$I_O = 5 \text{ to } 500 \text{ mA}$, $T_J = 25 \text{ °C}$			480	mV
		$I_O = 5 \text{ to } 200 \text{ mA}$, $T_J = 25 \text{ °C}$			240	
I_d	Quiescent current	$T_J = 25 \text{ °C}$			6	mA

Symbol	Parameter	Test conditions	Min.	Typ.	Max.	Unit
ΔI_d	Quiescent current change	$I_O = 5$ to 350 mA			0.5	mA
		$I_O = 200$ mA, $V_I = 27$ to 38 V			0.8	
$\Delta V_O/\Delta T$	Output voltage drift	$I_O = 5$ mA		-1.2		mV/°C
SVR	Supply voltage rejection	$V_I = 28$ to 38 V, $f = 120$ Hz, $I_O = 300$ mA, $T_J = 25$ °C	50			dB
eN	Output noise voltage	$B = 10$ Hz to 100 kHz, $T_J = 25$ °C		170		μ V
V_d	Dropout voltage	$T_J = 25$ °C		2		V
I_{sc}	Short circuit current	$V_I = 35$ V, $T_J = 25$ °C		240		mA
I_{scp}	Short circuit peak current	$T_J = 25$ °C		700		mA

6 Typical performance

Figure 8. Dropout voltage vs junction temp.

Figure 9. Dropout characteristics

Figure 10. Peak output current vs input-output differential voltage

Figure 11. Output voltage vs junction temperature

Figure 12. Supply voltage rejection vs frequency

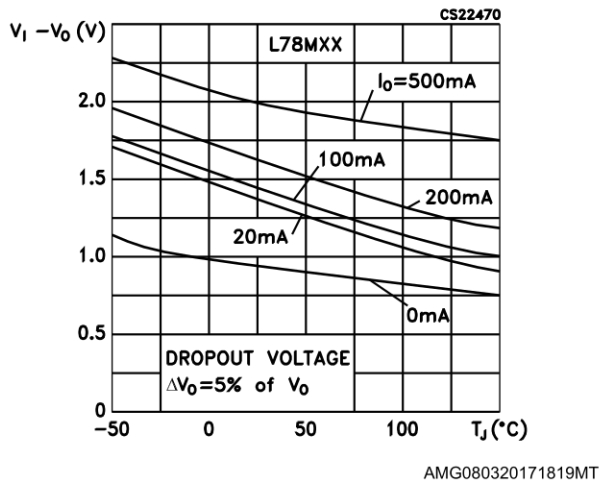
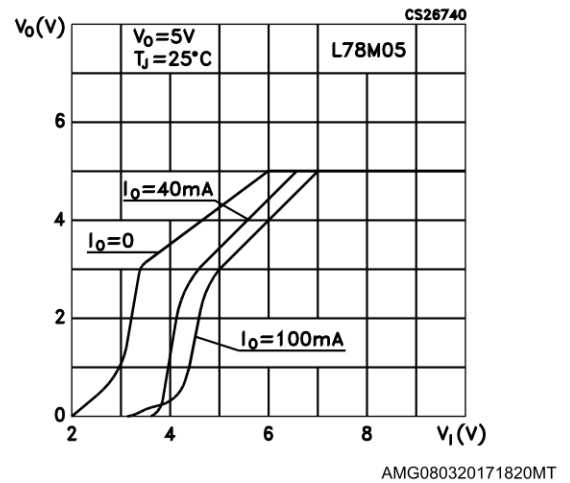
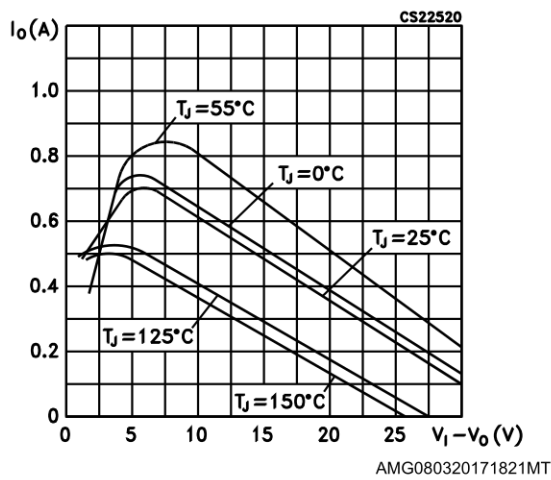
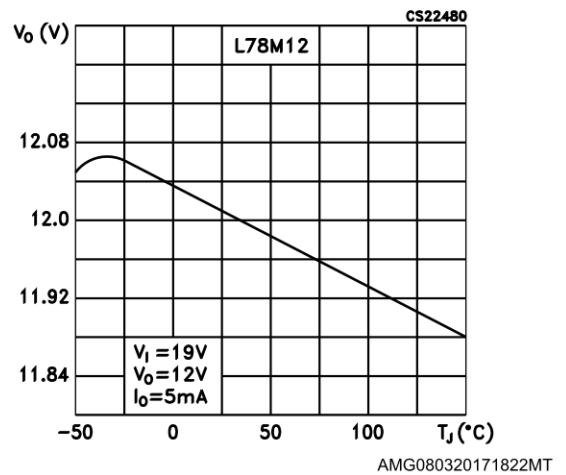
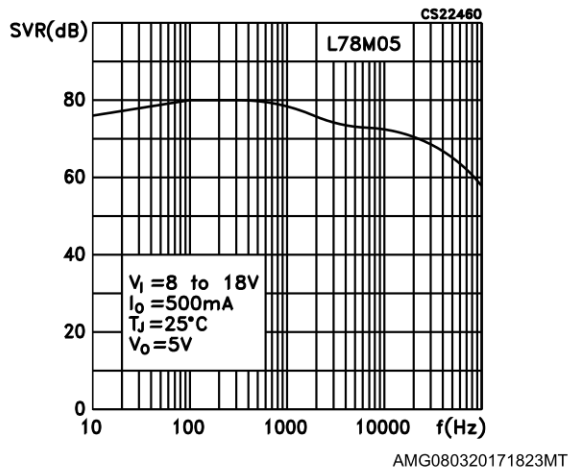

Figure 13. Quiescent current vs junction temperature

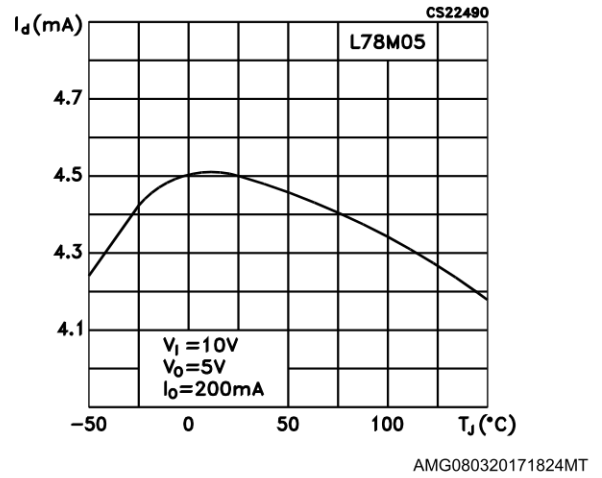

Figure 14. Load transient response

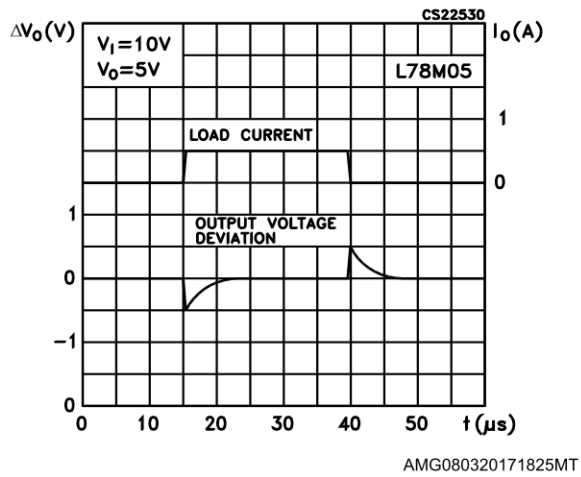

Figure 15. Line transient response

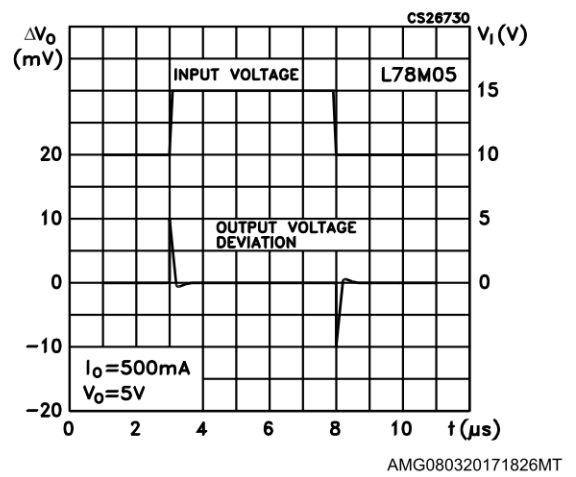
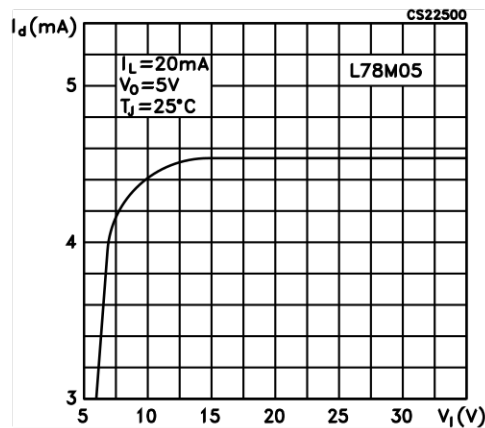

Figure 16. Quiescent current vs input voltage



7 Applications information

7.1 Design considerations

The L78M series of fixed voltage regulators are designed with thermal overload protection that shuts down the circuit when subjected to an excessive power overload condition, internal short-circuit protection that limits the maximum current the circuit will pass, and output transistor safe-area compensation that reduces the output short-circuit as the voltage across the pass transistor is increased. In many low current applications, compensation capacitors are not required. However, it is recommended that the regulator input be bypassed with a capacitor if the regulator is connected to the power supply filter with long wire lengths, or if the output load capacitance is large. An input bypass capacitor should be selected to provide good high-frequency characteristics to insure stable operation under all load conditions. A 0.33 μF or larger tantalum, mylar, or other capacitor having low internal impedance at high frequencies should be chosen. The bypass capacitor should be mounted with the shortest possible leads directly across the regulators input terminals. Normally good construction techniques should be used to minimize ground loops and lead resistance drops since the regulator has no external sense lead.

Figure 17. Fixed output regulator

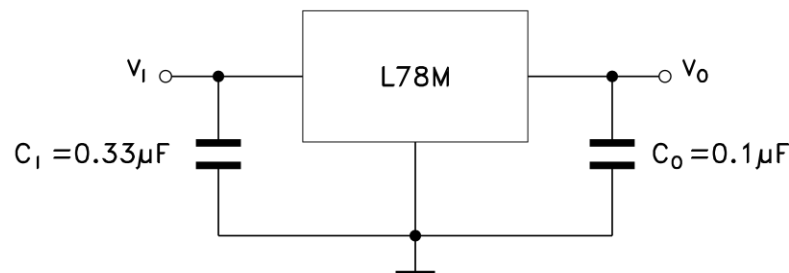

AMG080320171807MT

Note: Although no output capacitor is need for stability, C_0 improve transient response if present. C_1 is required if regulator is located an appreciable distance from power supply filter.

Figure 18. Constant current regulator

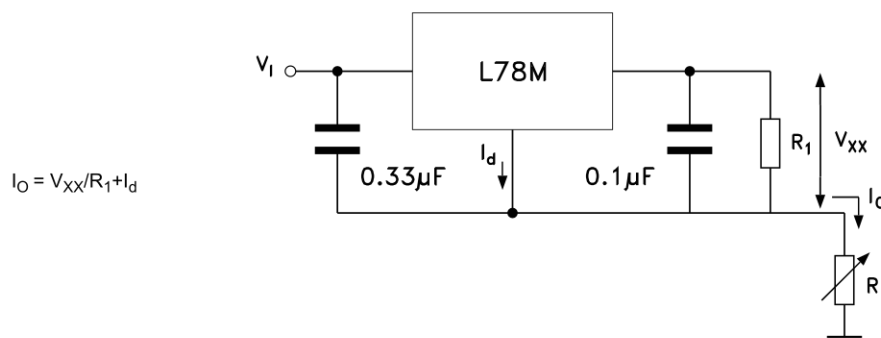

AMG080320171808MT

Figure 19. Circuit for increasing output voltage

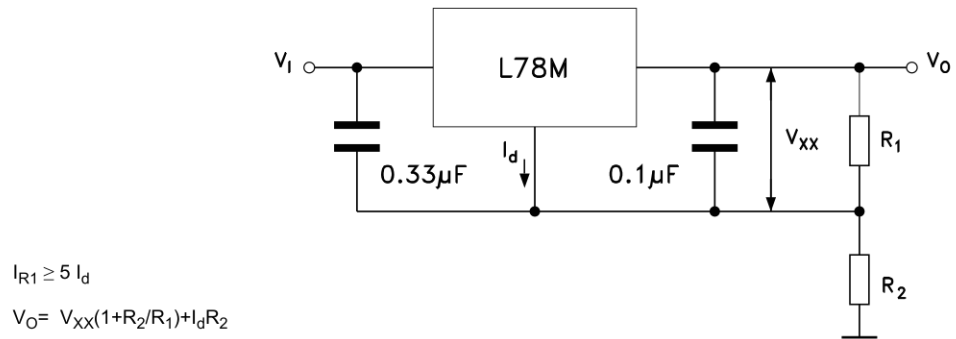

AMG080320171809MT

Figure 20. Adjustable output regulator (7 to 30 V)

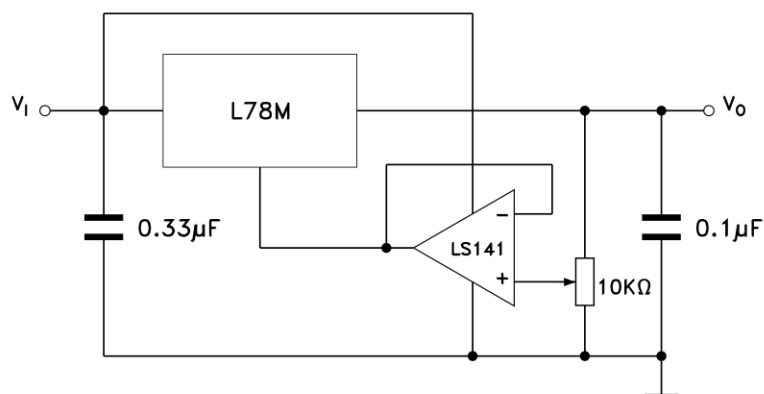

AMG080320171811MT

Figure 21. 0.5 to 10 V regulator

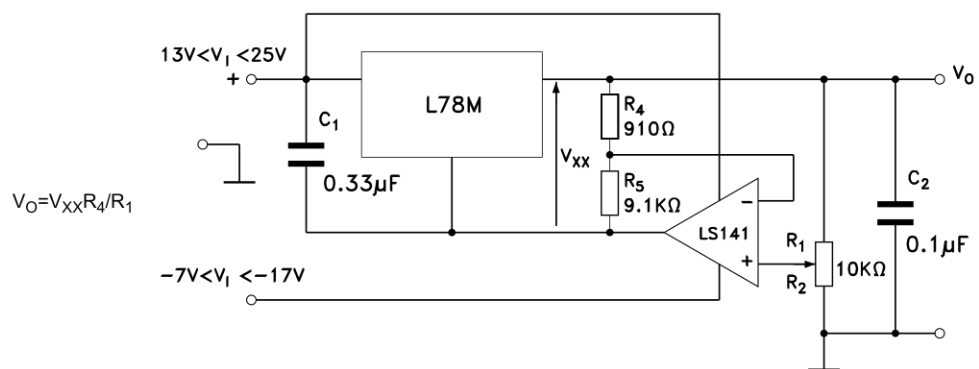

AMG080320171812MT

Figure 22. High current voltage regulator

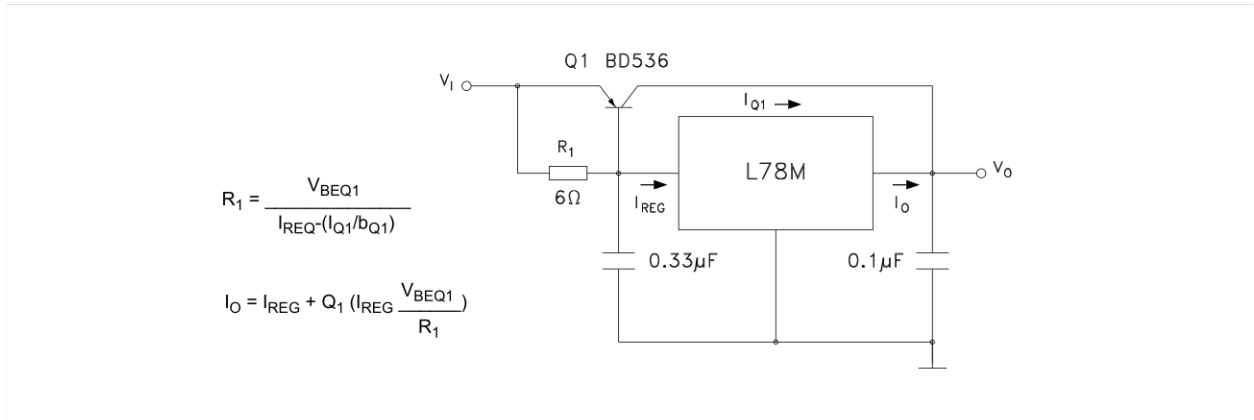
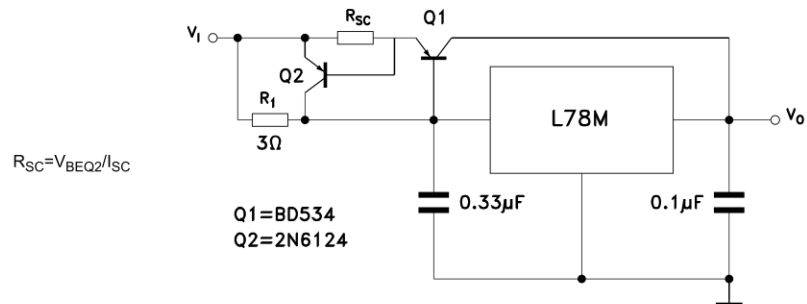
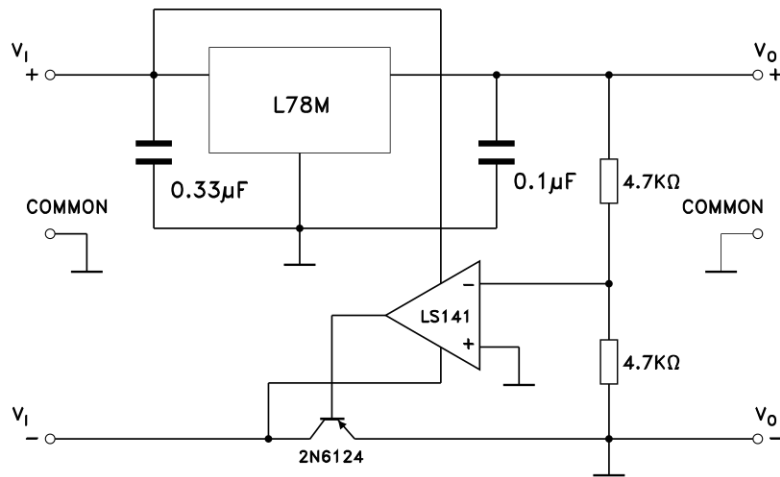

Figure 23. High output current with short circuit protection



AMG080320171828MT

Figure 24. Tracking voltage regulator



AMG080320171814MT

Figure 25. High input voltage circuit

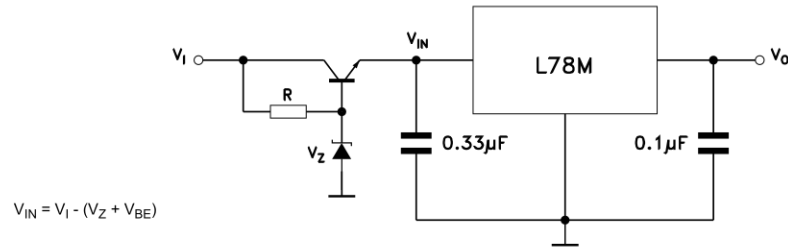

AMG080320171815MT

Figure 26. Reducing power dissipation with dropping resistor

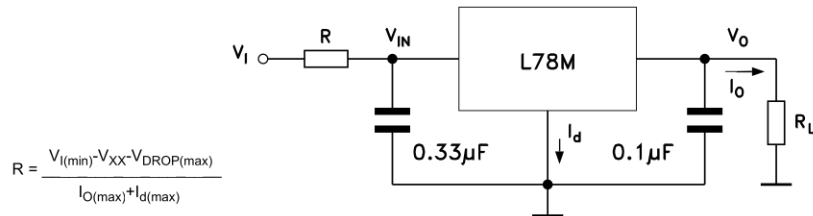

AMG080320171816MT

Figure 27. Power AM modulator (unity voltage gain, $I_O \leq 0.5$)

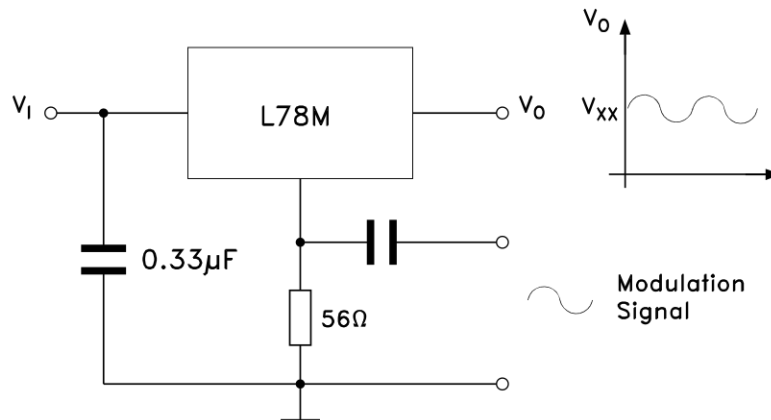

AMG080320171817MT

Note: The circuit performs well up to 100 kHz.

Figure 28. Adjustable output voltage with temperature compensation

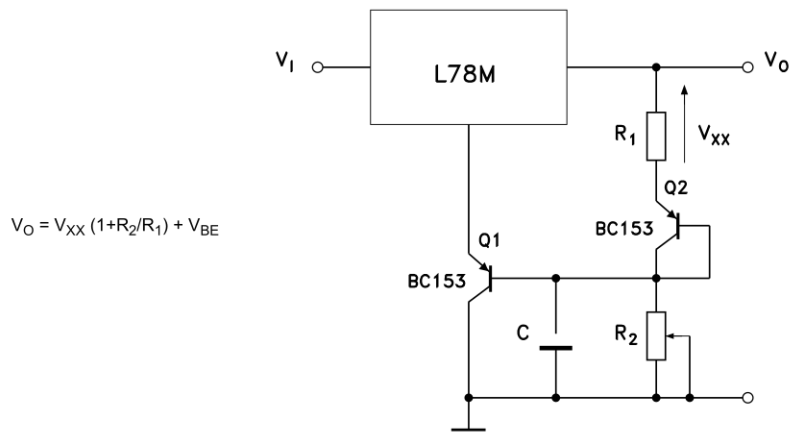

Note: Q_2 is connected as a diode in order to compensate the variation of the Q_1 V_{BE} with the temperature. C allows a slow rise time of the V_O .

8 Package information

In order to meet environmental requirements, ST offers these devices in different grades of **ECOPACK** packages, depending on their level of environmental compliance. ECOPACK specifications, grade definitions and product status are available at: www.st.com. ECOPACK is an ST trademark.

8.1 TO-220 (single gauge) package information

Figure 29. TO-220 (single gauge) package outline

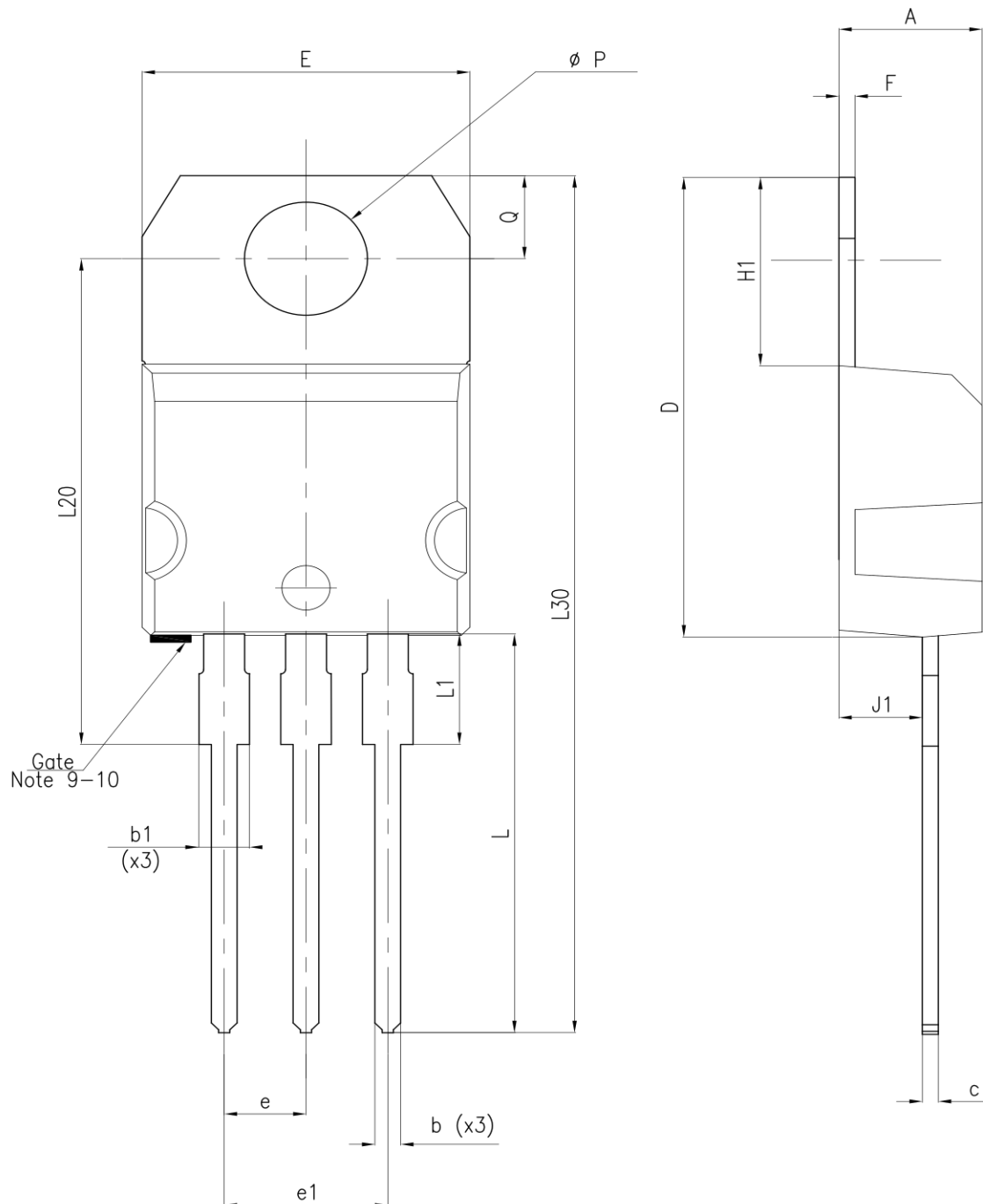

8174627_5

Table 18. TO-220 (single gauge) mechanical data

Dim.	mm		
	Min.	Typ.	Max.
A	4.40		4.60
b	0.61		0.88
b1	1.14		1.70
c	0.48		0.70
D	15.25		15.75
E	10.00		10.40
e	2.40		2.70
e1	4.95		5.15
F	0.51		0.60
H1	6.20		6.60
J1	2.40		2.72
L	13.00		14.00
L1	3.50		3.93
L20		16.40	
L30		28.90	
ØP	3.75		3.85
Q	2.65		2.95

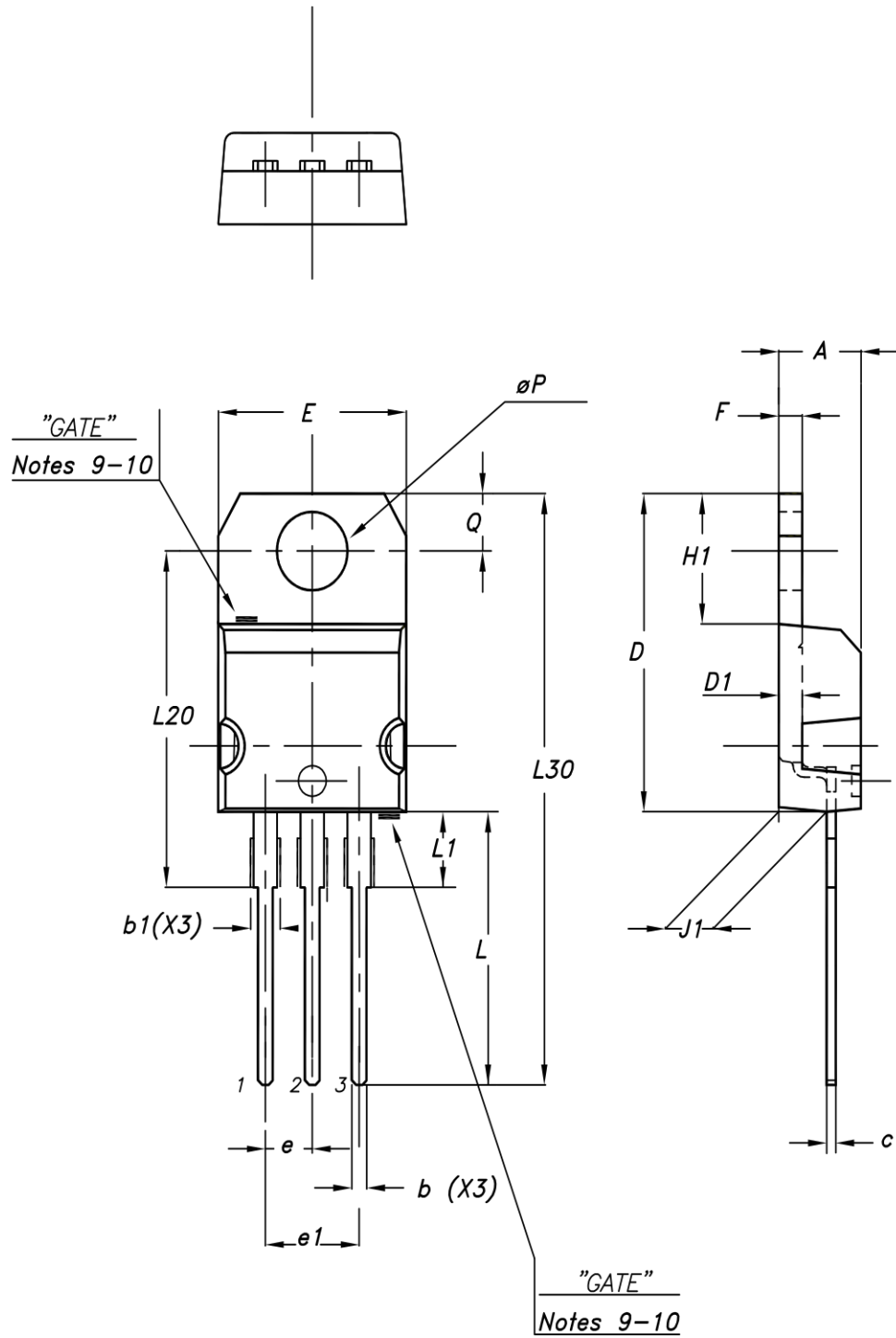
8.2 TO-220 (dual gauge) package information
Figure 30. TO-220 (dual gauge) package outline

0015988_21_Type A

Table 19. TO-220 (dual gauge) mechanical data

Dim.	mm		
	Min.	Typ.	Max.
A	4.40		4.60
b	0.61		0.88
b1	1.14		1.70
c	0.48		0.70
D	15.25		15.75
D1		1.27	
E	10		10.40
e	2.40		2.70
e1	4.95		5.15
F	1.23		1.32
H1	6.20		6.60
J1	2.40		2.72
L	13		14
L1	3.50		3.93
L20		16.40	
L30		28.90	
∅P	3.75		3.85
Q	2.65		2.95

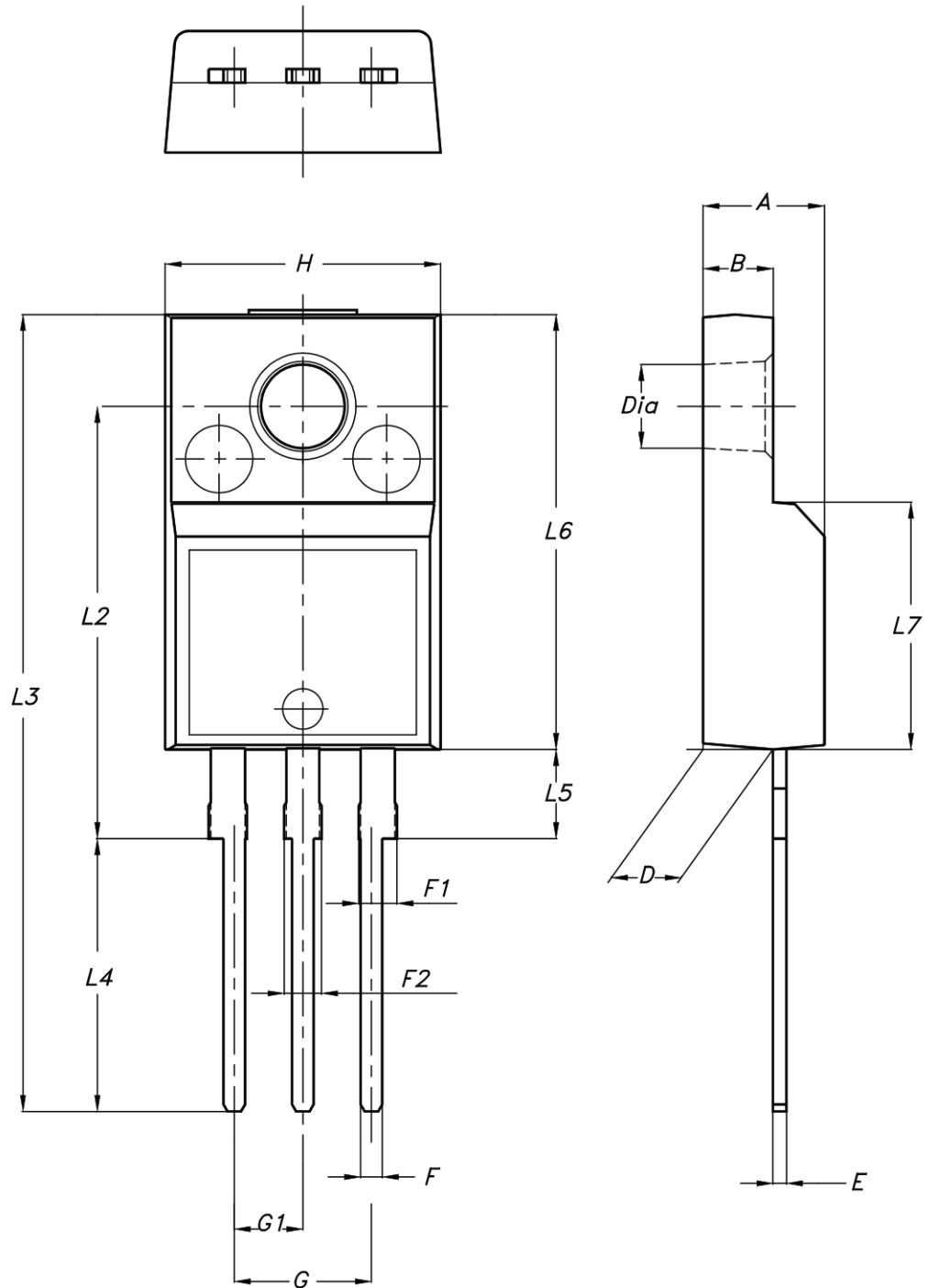
8.3 TO-220FP type A package information
Figure 31. TO-220FP package outline

7012510_type_A

Table 20. TO-220FP package mechanical data

Dim.	mm		
	Min.	Typ.	Max.
A	4.4		4.6
B	2.5		2.7
D	2.5		2.75
E	0.45		0.7
F	0.75		1
F1	1.15		1.70
F2	1.15		1.70
G	4.95		5.2
G1	2.4		2.7
H	10		10.4
L2		16	
L3	28.6		30.6
L4	9.8		10.6
L5	2.9		3.6
L6	15.9		16.4
L7	9		9.3
Dia	3		3.2

8.4 DPAK (TO-252) package information

Table 21. DPAK (TO-252) mechanical data (type A)

Dim.	mm		
	Min.	Typ.	Max.
A	2.20		2.40
A1	0.90		1.10
A2	0.03		0.23
b	0.64		0.90
b4	5.20		5.40
c	0.45		0.60
c2	0.48		0.60
D	6.00		6.20
D1	4.95	5.10	5.25
E	6.40		6.60
E1	4.60	4.70	4.80
e	2.159	2.286	2.143
e1	4.445	4.572	4.699
H	9.35		10.10
L	1.00		1.50
L1	2.60	2.80	3.00
L2	0.65	0.80	0.95
L4	0.60		1.00
R		0.20	
V2	0°		8°

Figure 32. DPAK (TO-252) package outline A

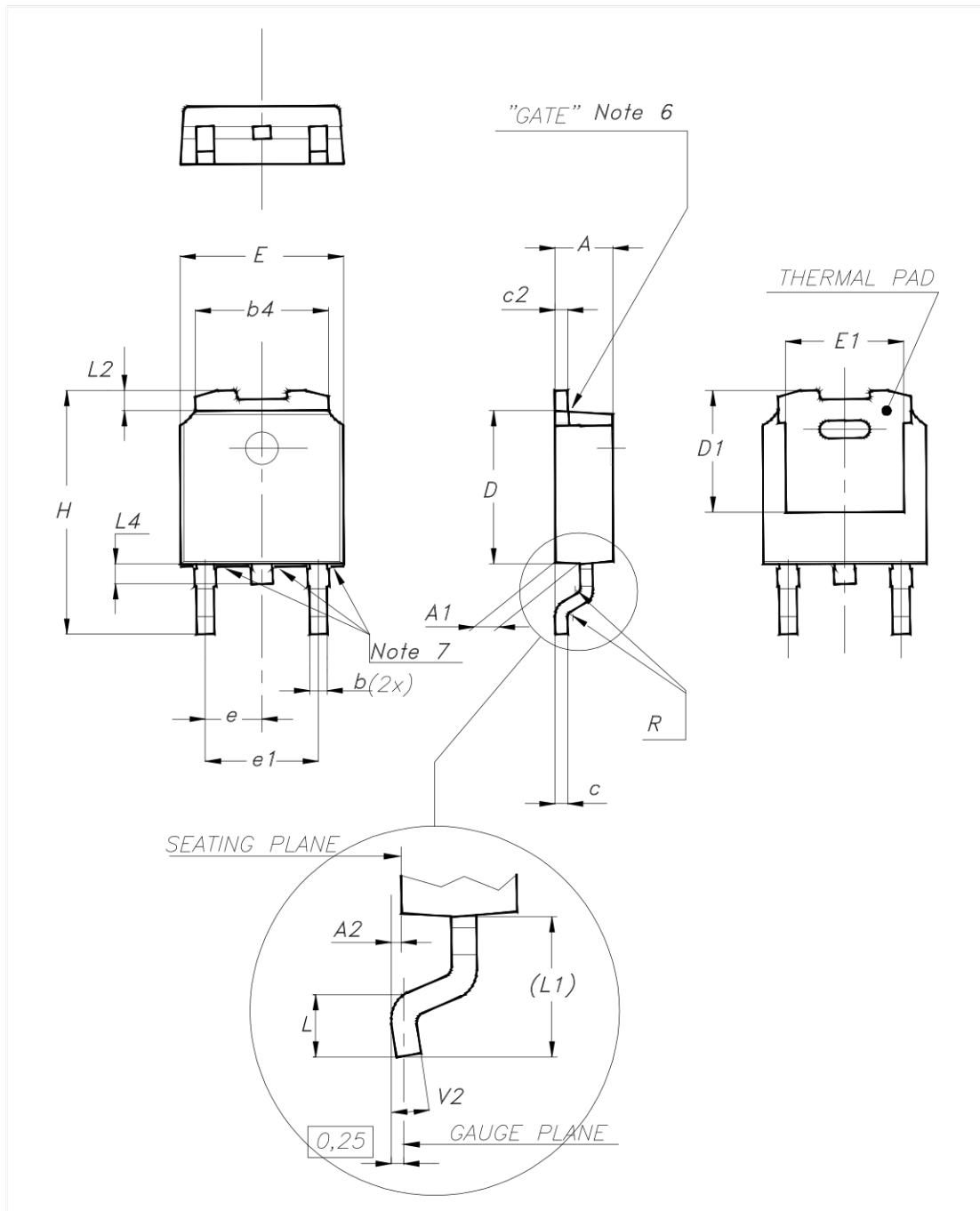

Table 22. DPAK(TO-252) mechanical data (type E)

Dim.	mm		
	Min.	Typ.	Max.
A	2.18		2.39
A2			0.13
b	0.65		0.884
b4	4.95		5.46
c	0.46		0.61
c2	0.46		0.60
D	5.97		6.22
D1	5.21		
E	6.35		6.73
E1	4.32		
e		2.286	
e1		4.572	
H	9.94		10.34
L	1.50		1.78
L1		2.74	
L2	0.89		1.27
L4			1.02

Figure 33. DPAK (TO-252) package outline E

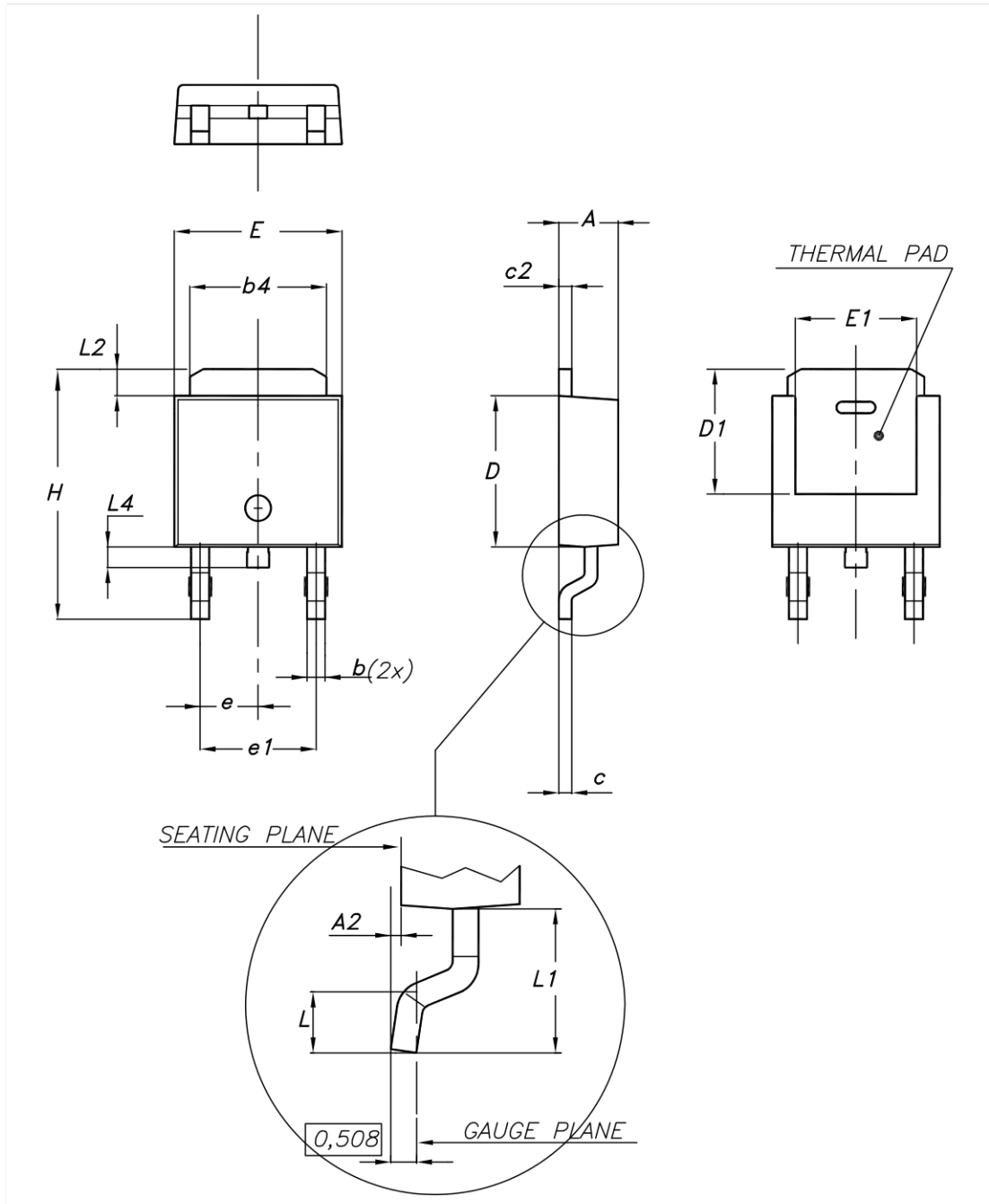
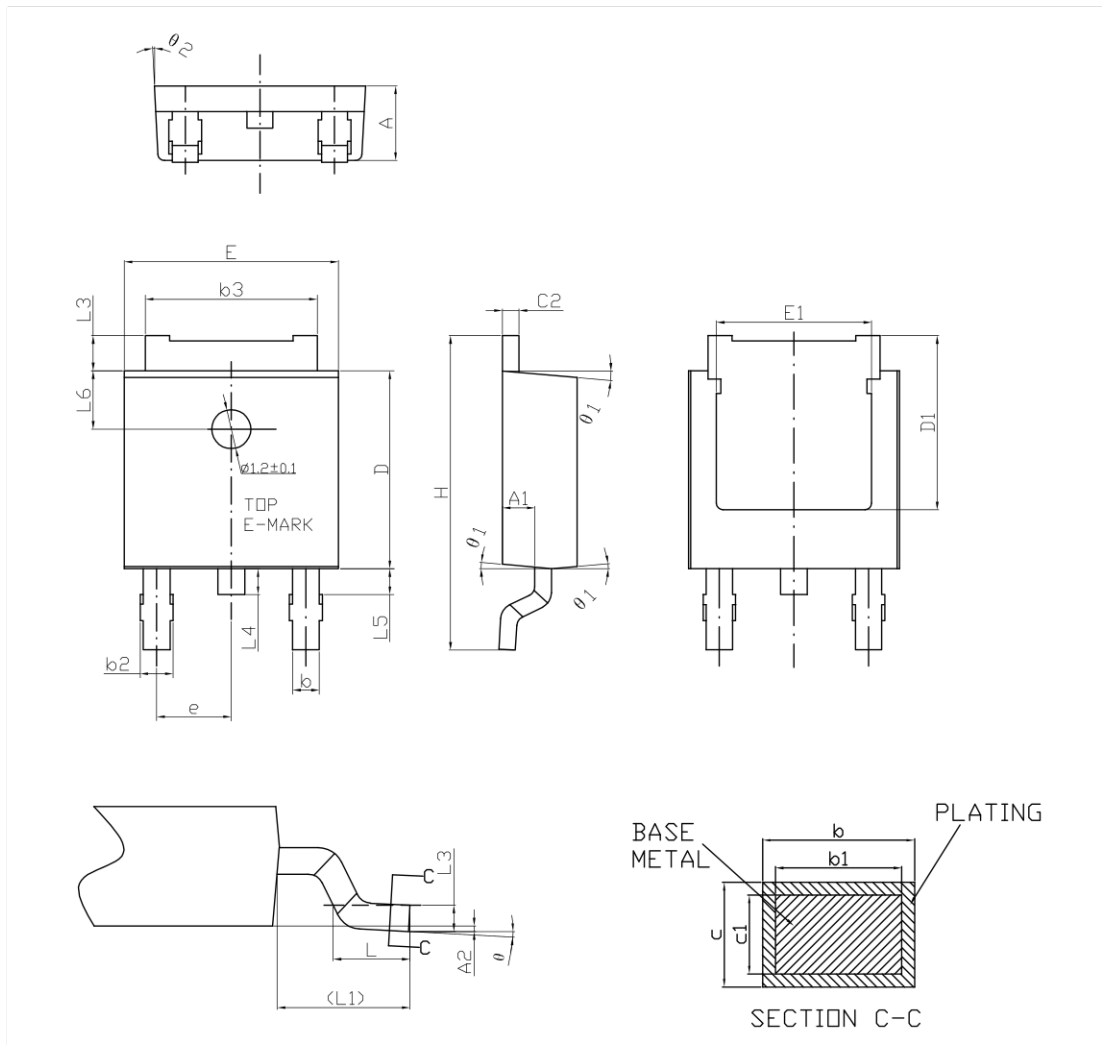

Table 23. DPAK (TO-252) mechanical data type I

Dim.	mm		
	Min.	Typ.	Max.
A	2.20	2.30	2.38
A1	0.90	1.01	1.10
A2	0.00	-	0.10
b	0.77	-	0.89
b1	0.76	0.81	0.86
b2	0.77	-	1.10
b3	5.23	5.33	5.43
c	0.47	-	0.60
c1	0.46	0.51	0.56
c2	0.47	-	0.60
D	6.00	6.10	6.20
D1	5.25	5.40	5.60
E	6.50	6.60	6.70
E1	4.70	4.85	5.00
e	2.286 BSC		
H	9.80	10.10	10.40
L	1.40	1.50	1.70
L1	2.90 REF		
L2	0.90	-	1.25
L3	0.51 BSC		
L4	0.60	0.80	1.00
L5	0.90	-	1.50
L6	1.80 BSC		
Θ	0°	-	8°
Θ1	3°	5°	7°
Θ2	1°	3°	5°

Figure 34. DPAK (TO-252) package outline I

Table 24. DPAK footprint data

	Values	
	mm.	inch.
A	6.70	0.264
B	6.70	0.64
C	1.80	0.070
D	3.00	0.118
E	1.60	0.063
F	2.30	0.091
G	2.30	0.091

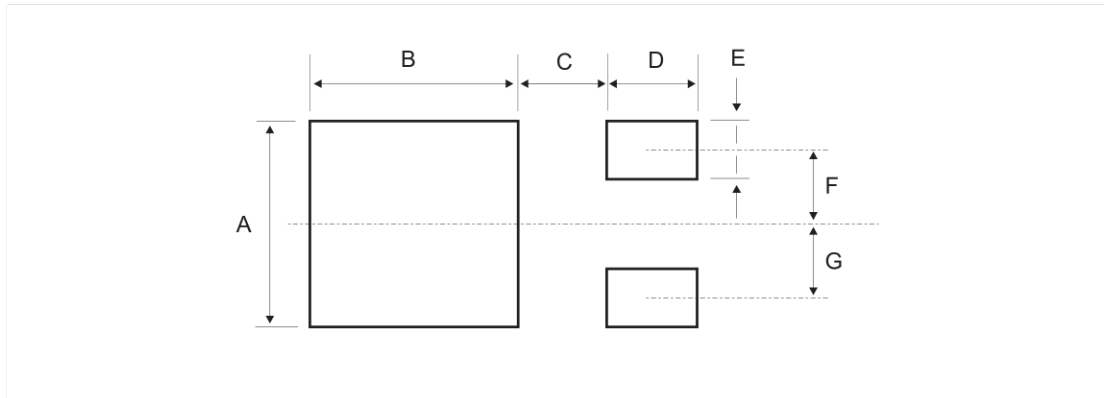
Figure 35. DPAK footprint recommended data



8.5 DPAK packing information

Figure 36. DPAK tape

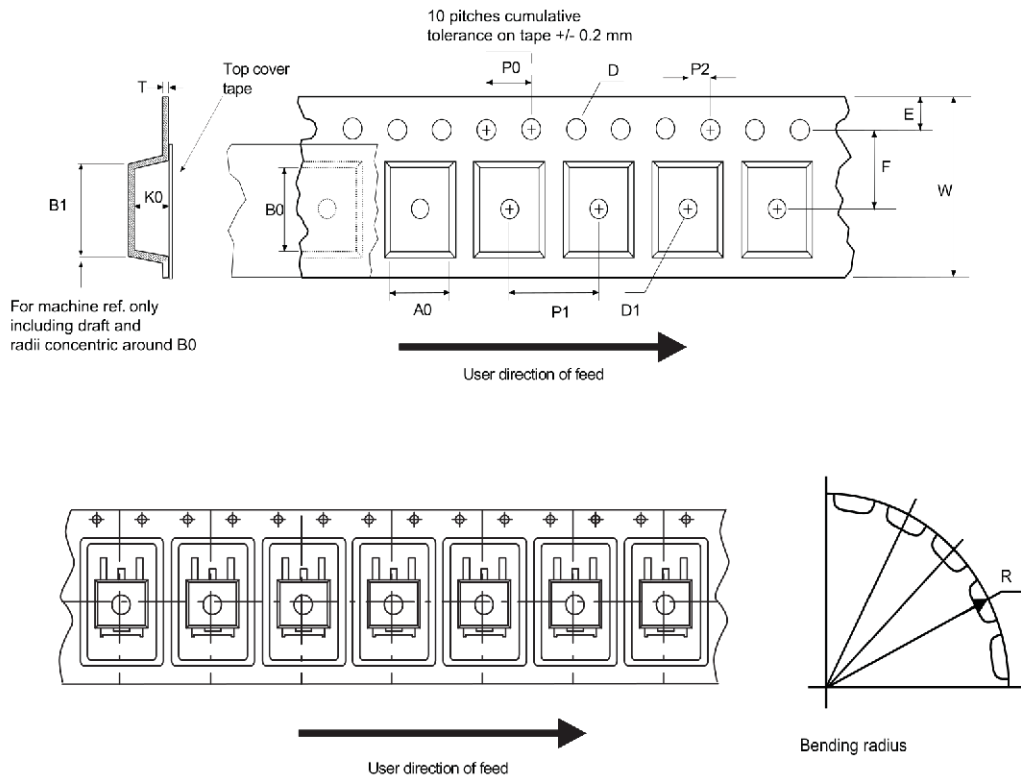

AM08852v1

Figure 37. DPAK reel

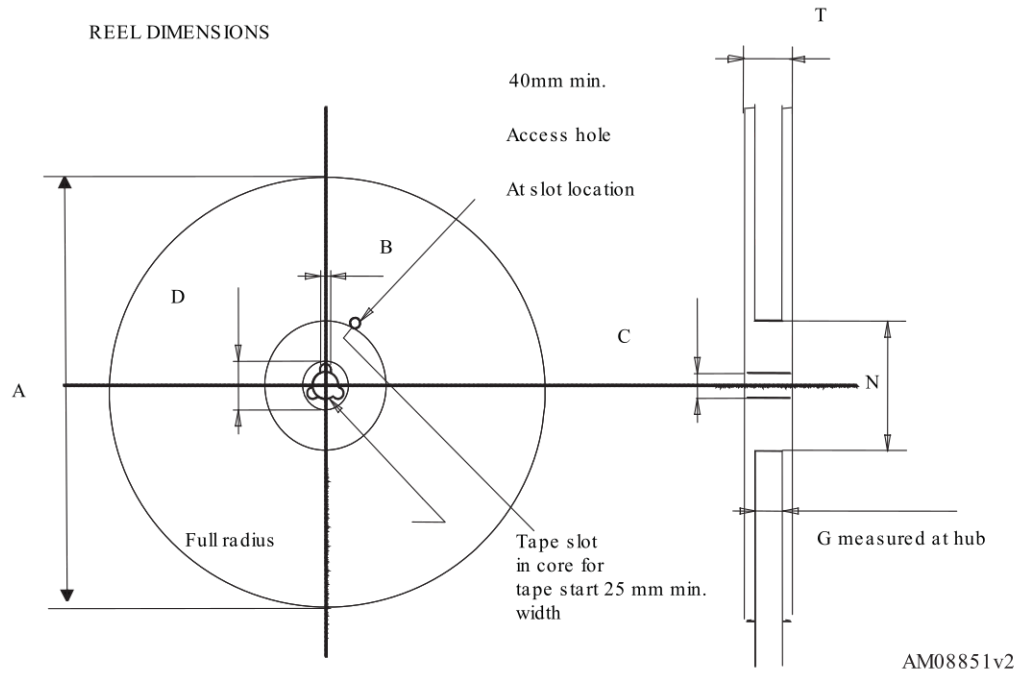
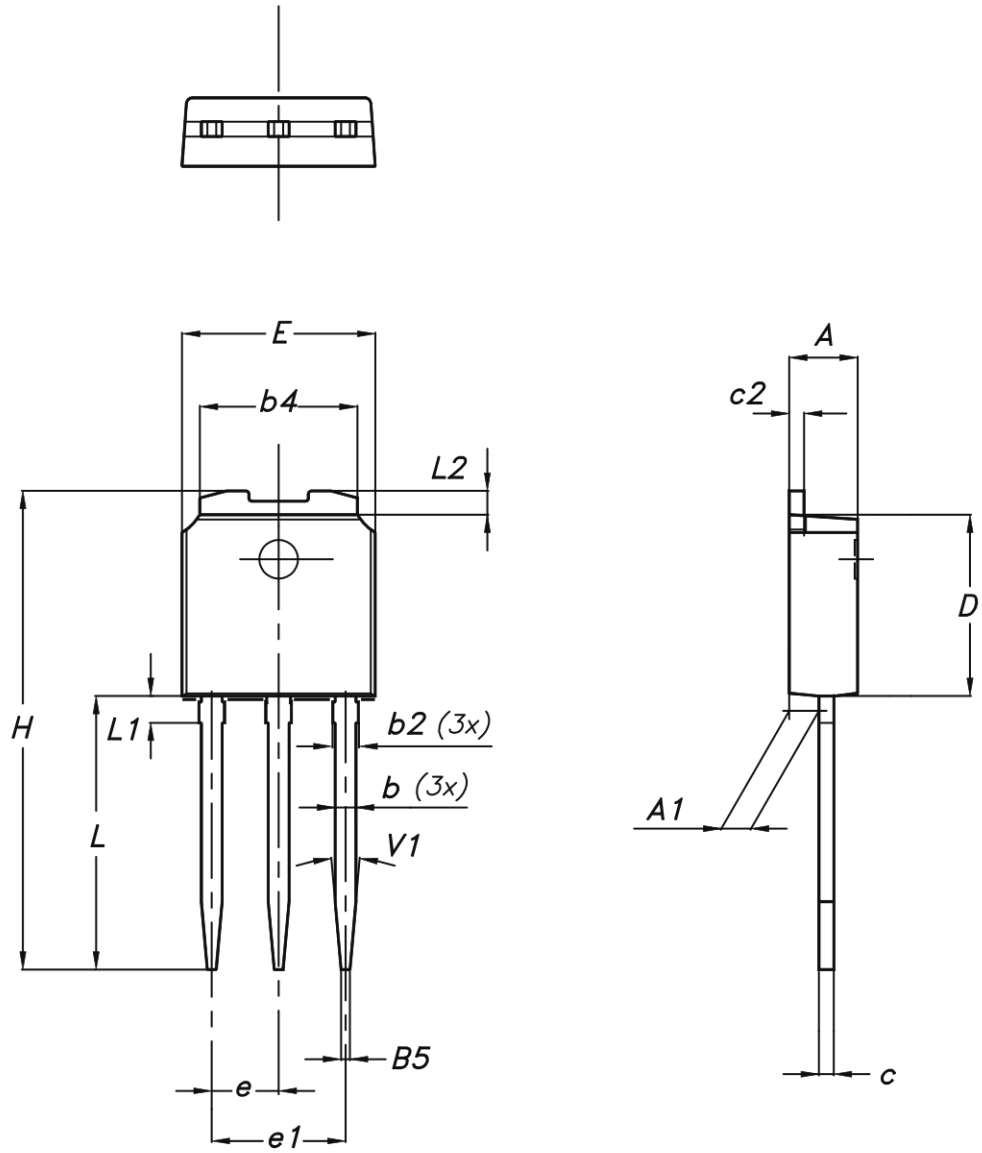

Table 25. DPAK tape and reel mechanical data

Dim.	Tape		Dim.	Reel	
	mm			mm	
	Min.	Max.		Min.	Max.
A0	6.8	7	A		330
B0	10.4	10.6	B	1.5	
B1		12.1	C	12.8	13.2
D	1.5	1.6	D	20.2	
D1	1.5		G	16.4	18.4
E	1.65	1.85	N	50	
F	7.4	7.6	T		22.4
K0	2.55	2.75			
P0	3.9	4.1		Base qty.	2500
P1	7.9	8.1		Bulk qty.	2500
P2	1.9	2.1			
R	40				
T	0.25	0.35			
W	15.7	16.3			

8.6 IPAK package information

Figure 38. IPAK package outline



0068771_K

Table 26. IPAK mechanical data

Dim.	mm		
	Min.	Typ.	Max.
A	2.20		2.40
A1	0.90		1.10
b	0.64		0.90
b2			0.95
b4	5.20		5.40
B5		0.30	
c	0.45		0.60
c2	0.48		0.60
D	6.00		6.20
E	6.40		6.60
e		2.28	
e1	4.40		4.60
H		16.10	
L	9.00		9.40
L1	0.80		1.20
L2		0.80	1.00
V1		10°	

9 Ordering information

Table 27. Order code

Order codes					Output voltages
TO-220 (single gauge)	TO-220 (dual gauge)	TO-220FP	DPAK	IPAK	
L78M05ABV	L78M05ABV-DG		L78M05ABDT-TR		5 V
			L78M05ACDT-TR		
L78M05CV	L78M05CV-DG	L78M05CP	L78M05CDT-TR	L78M05CDT-1	5 V
			L78M06ABDT-TR		6 V
			L78M06CDT-TR		6 V
			L78M08ABDT-TR		8 V
L78M08CV	L78M08CV-DG		L78M08CDT-TR		8 V
			L78M09ABDT-TR		9 V
L78M09CV	L78M09CV-DG		L78M09CDT-TR		9 V
			L78M10ABDT-TR		10 V
			L78M12ABDT-TR		12 V
			L78M12ACDT-TR		12 V
L78M12CV	L78M12CV-DG		L78M12CDT-TR		12 V
L78M15ABV	L78M15ABV-DG		L78M15ABDT-TR		15 V
L78M15CV	L78M15CV-DG		L78M15CDT-TR		15 V
			L78M24ABDT-TR		24 V
			L78M24ACDT-TR		24 V
L78M24CV	L78M24CV-DG		L78M24CDT-TR		24 V

Revision history

Table 28. Document revision history

Date	Revision	Changes
21-Jun-2004	6	Document updating.
30-Aug-2006	7	Order codes updated.
29-Nov-2006	8	DPAK mechanical data updated and add footprint data.
06-Jun-2007	9	Order codes updated.
10-Dec-2007	10	Added Table 25.
19-Feb-2008	11	Modified: Table 25 on page 44.
15-Jul-2008	12	Modified: Table 25 on page 44 and Table 26 on page 45.
07-Apr-2009	13	Modified: Figure 9 on page 22 and Figure 15 on page 23.
14-Jun-2010	14	Added: Table 18 on page 26, Figure 29 on page 27, Figure 30 on page 28, Figure 31 and Figure 32 on page 29.
11-Nov-2010	15	Modified: R_{thJC} value for TO-220 Table 2 on page 5.
08-Feb-2012	16	Added: order codes L78M05CV-DG, L78M12CV-DG and L78M15CV-DG Table 25 on page 44.
09-Mar-2012	17	Added: order codes L78M08CV-DG and L78M09CV-DG Table 25 on page 44.
15-May-2012	18	Added: order codes L78M24CV-DG Table 25 on page 44.
19-Apr-2013	19	Removed: Available on request footnote 2 Table 25 on page 44.
04-Jun-2014	20	<p>Part numbers L78MxxAB, L78MxxAC and L78MxxC changed to L78M.</p> <p>Updated the title and the features in cover page.</p> <p>Canceled Table 1.Device summary.</p> <p>Updated Section 3: Maximum ratings, Section 5: Electrical characteristics, Section 6: Typical performance and Section 8: Package mechanical data.</p> <p>Added Section 7: Applications information and Section 9: Packaging mechanical data.</p> <p>Minor text changes.</p>
21-Mar-2017	21	<p>Updated Section 8: "Package information" (DPAK package information changed from type F to type I).</p> <p>Minor text changes.</p>
12-Jun-2019	22	Updated Section 8.4 DPAK (TO-252) package information.
26-Nov-2019	23	<p>Added Table 21. DPAK (TO-252) mechanical data (type A), Table 22. DPAK(TO-252) mechanical data (type E) and Table 23. DPAK (TO-252) mechanical data type I</p> <p>Updated Figure 34. DPAK (TO-252) package outline I.</p>
07-Sep-2020	24	Updated Table 21. DPAK (TO-252) mechanical data (type A).

Contents

1	Diagram	2
2	Pin configuration	3
3	Maximum ratings	5
4	Test circuits	6
5	Electrical characteristics	7
6	Typical performance	16
7	Applications information	18
7.1	Design considerations	18
8	Package information	23
8.1	TO-220 (single gauge) package information	23
8.2	TO-220 (dual gauge) package information	25
8.3	TO-220FP package information	27
8.4	DPAK (TO-252) package information	29
8.5	DPAK packing information	36
8.6	IPAK package information	38
9	Ordering information	40
	Revision history	41
	Contents	42
	List of tables	43
	List of figures	44

List of tables

Table 1.	Absolute maximum ratings	5
Table 2.	Thermal data	5
Table 3.	Electrical characteristics of L78M05C	7
Table 4.	Electrical characteristics of L78M05A	8
Table 5.	Electrical characteristics of L78M06C	8
Table 6.	Electrical characteristics of L78M06A	9
Table 7.	Electrical characteristics of L78M08C	9
Table 8.	Electrical characteristics of L78M08A	10
Table 9.	Electrical characteristics of L78M09C	10
Table 10.	Electrical characteristics of L78M09A	11
Table 11.	Electrical characteristics of L78M10A	11
Table 12.	Electrical characteristics of L78M12C	12
Table 13.	Electrical characteristics of L78M12A	12
Table 14.	Electrical characteristics of L78M15C	13
Table 15.	Electrical characteristics of L78M15A	13
Table 16.	Electrical characteristics of L78M24C	14
Table 17.	Electrical characteristics of L78M24A	14
Table 18.	TO-220 (single gauge) mechanical data	24
Table 19.	TO-220 (dual gauge) mechanical data	26
Table 20.	TO-220FP package mechanical data	28
Table 21.	DPAK (TO-252) mechanical data (type A)	29
Table 22.	DPAK(TO-252) mechanical data (type E)	31
Table 23.	DPAK (TO-252) mechanical data type I	33
Table 24.	DPAK footprint data	34
Table 25.	DPAK tape and reel mechanical data	37
Table 26.	IPAK mechanical data	39
Table 27.	Order code	40
Table 28.	Document revision history	41

List of figures

Figure 1.	Block diagram	2
Figure 2.	Pin connections (top view)	3
Figure 3.	Schematic diagram	4
Figure 4.	Application circuit	5
Figure 5.	DC parameter.	6
Figure 6.	Load regulation.	6
Figure 7.	Ripple rejection.	6
Figure 8.	Dropout voltage vs junction temp.	16
Figure 9.	Dropout characteristics	16
Figure 10.	Peak output current vs input-output differential voltage	16
Figure 11.	Output voltage vs junction temperature	16
Figure 12.	Supply voltage rejection vs frequency	17
Figure 13.	Quiescent current vs junction temperature	17
Figure 14.	Load transient response	17
Figure 15.	Line transient response	17
Figure 16.	Quiescent current vs input voltage	17
Figure 17.	Fixed output regulator	18
Figure 18.	Constant current regulator	18
Figure 19.	Circuit for increasing output voltage.	19
Figure 20.	Adjustable output regulator (7 to 30 V).	19
Figure 21.	0.5 to 10 V regulator	19
Figure 22.	High current voltage regulator.	20
Figure 23.	High output current with short circuit protection.	20
Figure 24.	Tracking voltage regulator	20
Figure 25.	High input voltage circuit	21
Figure 26.	Reducing power dissipation with dropping resistor.	21
Figure 27.	Power AM modulator (unity voltage gain, $I_O \leq 0.5$).	21
Figure 28.	Adjustable output voltage with temperature compensation	22
Figure 29.	TO-220 (single gauge) package outline	23
Figure 30.	TO-220 (dual gauge) package outline	25
Figure 31.	TO-220FP package outline.	27
Figure 32.	DPAK (TO-252) package outline A	30
Figure 33.	DPAK (TO-252) package outline E	32
Figure 34.	DPAK (TO-252) package outline I	34
Figure 35.	DPAK footprint recommended data	35
Figure 36.	DPAK tape	36
Figure 37.	DPAK reel	37
Figure 38.	IPAK package outline	38

IMPORTANT NOTICE – PLEASE READ CAREFULLY

STMicroelectronics NV and its subsidiaries (“ST”) reserve the right to make changes, corrections, enhancements, modifications, and improvements to ST products and/or to this document at any time without notice. Purchasers should obtain the latest relevant information on ST products before placing orders. ST products are sold pursuant to ST’s terms and conditions of sale in place at the time of order acknowledgement.

Purchasers are solely responsible for the choice, selection, and use of ST products and ST assumes no liability for application assistance or the design of Purchasers’ products.

No license, express or implied, to any intellectual property right is granted by ST herein.

Resale of ST products with provisions different from the information set forth herein shall void any warranty granted by ST for such product.

ST and the ST logo are trademarks of ST. For additional information about ST trademarks, please refer to www.st.com/trademarks. All other product or service names are the property of their respective owners.

Information in this document supersedes and replaces information previously supplied in any prior versions of this document.

© 2020 STMicroelectronics – All rights reserved