

## High voltage power Schottky rectifier

Datasheet - production data

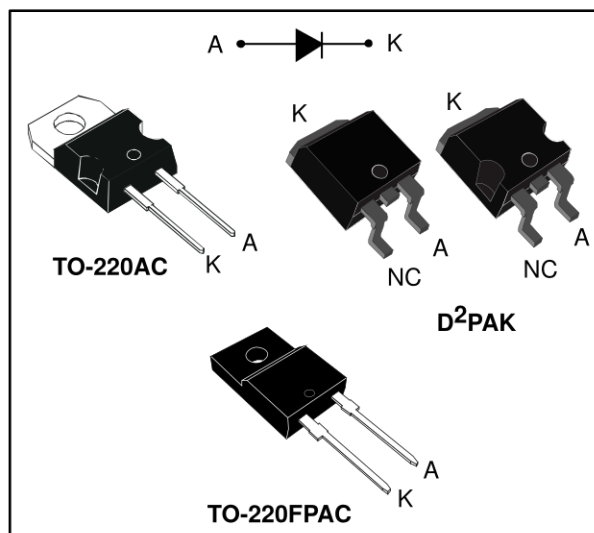

### Features

- Negligible switching losses
- High junction temperature capability
- Low leakage current
- Good trade off between leakage current and forward voltage drop
- Insulated package:
  - TO-220FPAC, insulating voltage = 2000 V<sub>RMS</sub> sine
- Avalanche capability specified
- ECOPACK<sup>®</sup>2 compliant component for D<sup>2</sup>PAK on demand

### Description

Schottky barrier rectifier designed for high frequency compact switched mode power supplies such as adaptors and on-board DC-DC converters.

**Table 1: Device summary**

Symbol	Value
$I_{F(AV)}$	8 A
$V_{RRM}$	100 V
$T_j$ (max)	175 °C
$V_F$ (typ)	0.56 V

# 1 Characteristics

**Table 2: Absolute ratings (limiting values, at 25 °C, unless otherwise specified)**

Symbol	Parameter		Value	Unit
V <sub>RRM</sub>	Repetitive peak reverse voltage		100	V
I <sub>F(RMS)</sub>	Forward rms current		30	A
I <sub>F(AV)</sub>	Average forward current $\delta = 0.5$ , square wave	TO-220AC, D <sup>2</sup> PAK	8	A
		TO-220FPAC		
I <sub>FSM</sub>	Surge non repetitive forward current	tp = 10 ms sinusoidal	250	A
P <sub>ARM</sub>	Repetitive peak avalanche power	tp = 10 $\mu$ s, T <sub>j</sub> = 125 °C	750	W
T <sub>stg</sub>	Storage temperature range		-65 to + 175	°C
T <sub>j</sub>	Maximum operating junction temperature <sup>(1)</sup>		+ 175	°C

**Notes:**

<sup>(1)</sup>(dP<sub>tot</sub>/dT<sub>j</sub>) < (1/R<sub>th(j-a)</sub>) condition to avoid thermal runaway for a diode on its own heatsink.

**Table 3: Thermal parameter**

Symbol	Parameter		Value	Unit
R <sub>th(j-c)</sub>	Junction to case	TO-220AC, D <sup>2</sup> PAK	1.6	°C/W
		TO-220FPAC	4	

**Table 4: Static electrical characteristics**

Symbol	Parameter	Test conditions		Min.	Typ.	Max.	Unit
I <sub>R</sub> <sup>(1)</sup>	Reverse leakage current	T <sub>j</sub> = 25 °C	V <sub>R</sub> = V <sub>RRM</sub>	-		4.5	$\mu$ A
		T <sub>j</sub> = 125 °C		-	2.0	6.0	mA
V <sub>F</sub> <sup>(2)</sup>	Forward voltage drop	T <sub>j</sub> = 25 °C	I <sub>F</sub> = 8 A	-		0.71	V
		T <sub>j</sub> = 125 °C		-	0.56	0.58	
		T <sub>j</sub> = 25 °C	I <sub>F</sub> = 10 A	-		0.77	
		T <sub>j</sub> = 125 °C		-	0.59	0.64	
		T <sub>j</sub> = 25 °C	I <sub>F</sub> = 16 A	-		0.81	
		T <sub>j</sub> = 125 °C		-	0.65	0.68	

**Notes:**

<sup>(1)</sup>Pulse test: t<sub>p</sub> = 5 ms,  $\delta < 2\%$

<sup>(2)</sup>Pulse test: t<sub>p</sub> = 380  $\mu$ s,  $\delta < 2\%$

To evaluate the conduction losses use the following equation:

$$P = 0.48 \times I_{F(AV)} + 0.0125 I_{F(RMS)}^2$$

### 1.1 Characteristics (curves)

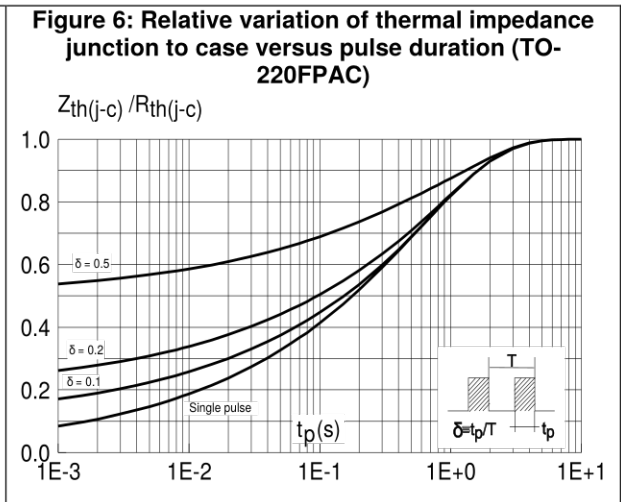
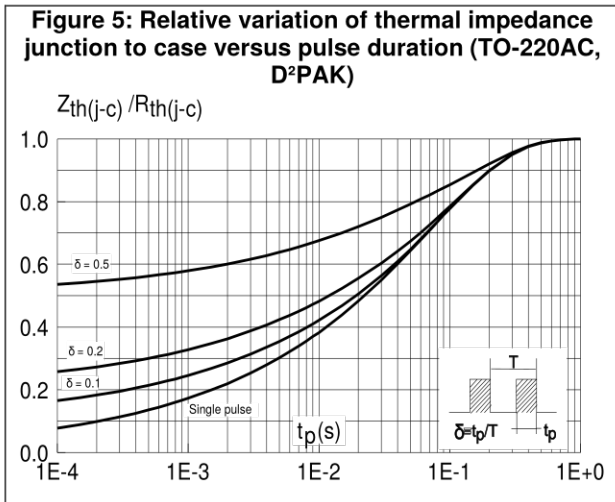
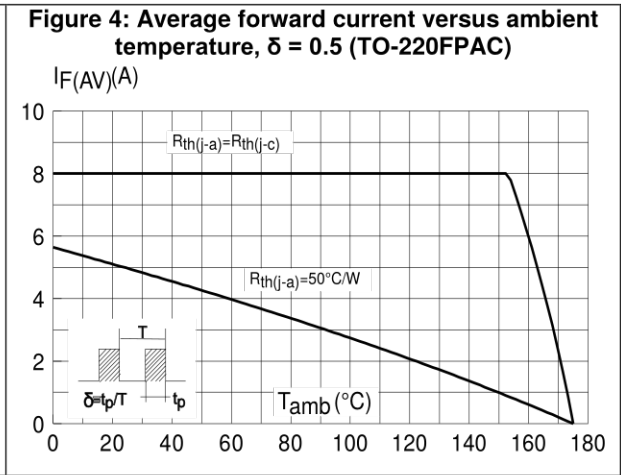
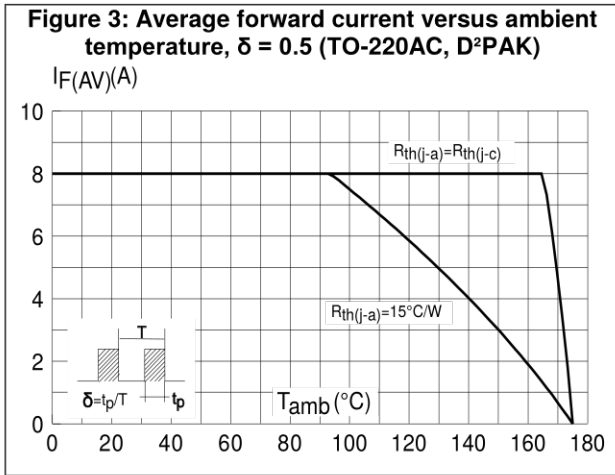
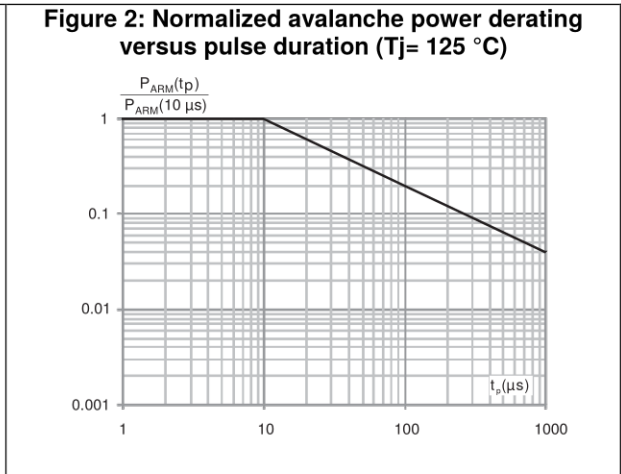
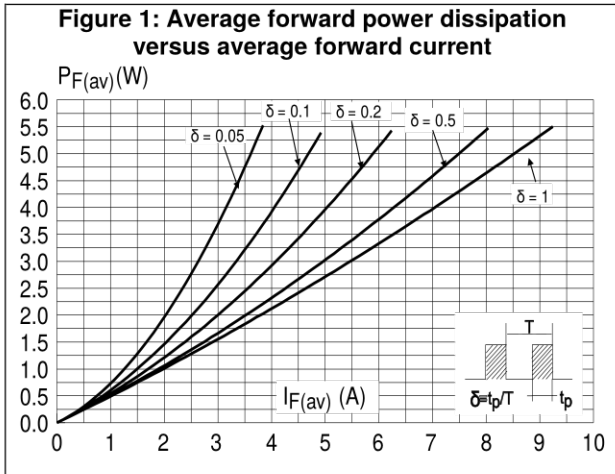

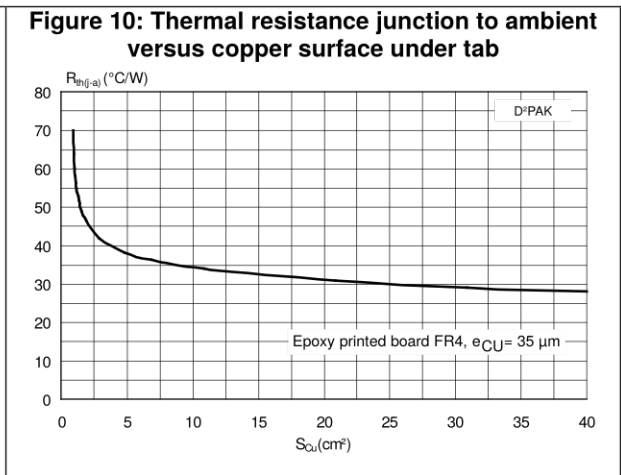
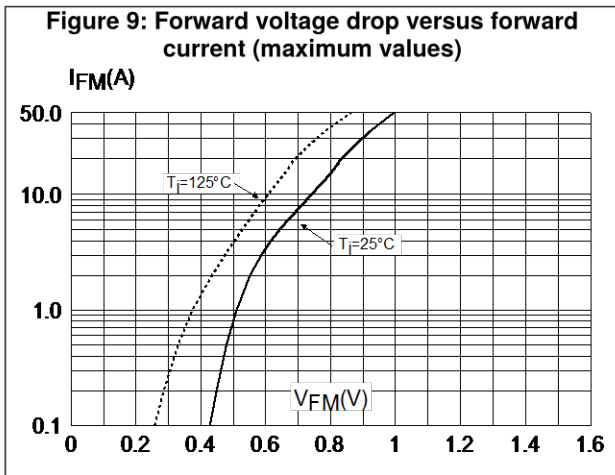
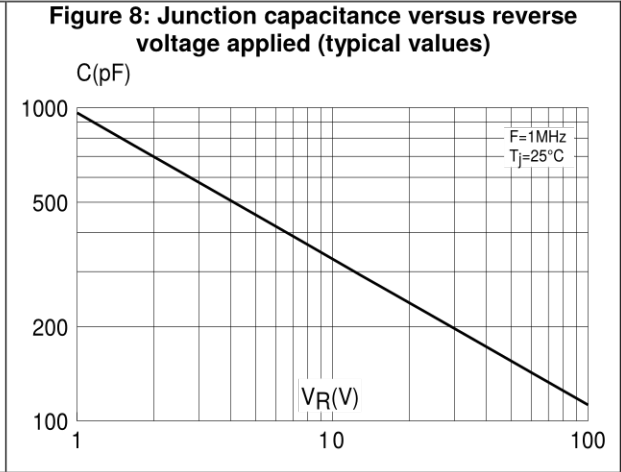
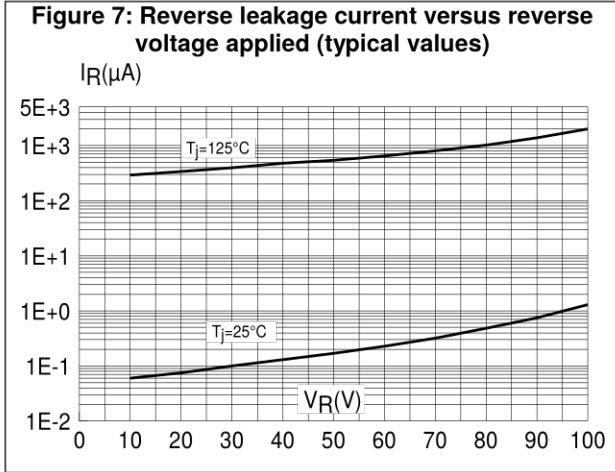

## 2 Package information

In order to meet environmental requirements, ST offers these devices in different grades of ECOPACK® packages, depending on their level of environmental compliance. ECOPACK® specifications, grade definitions and product status are available at: [www.st.com](http://www.st.com). ECOPACK® is an ST trademark.

- Cooling method: by conduction (C)
- Epoxy meets UL 94, V0
- Recommended torque value: 0.55 N·m (for TO-220AC and TO-220FPAC)
- Maximum torque value: 0.7 N·m (for TO-220AC and TO-220FPAC)

## 2.1 D<sup>2</sup>PAK package information

Figure 11: D<sup>2</sup>PAK package outline

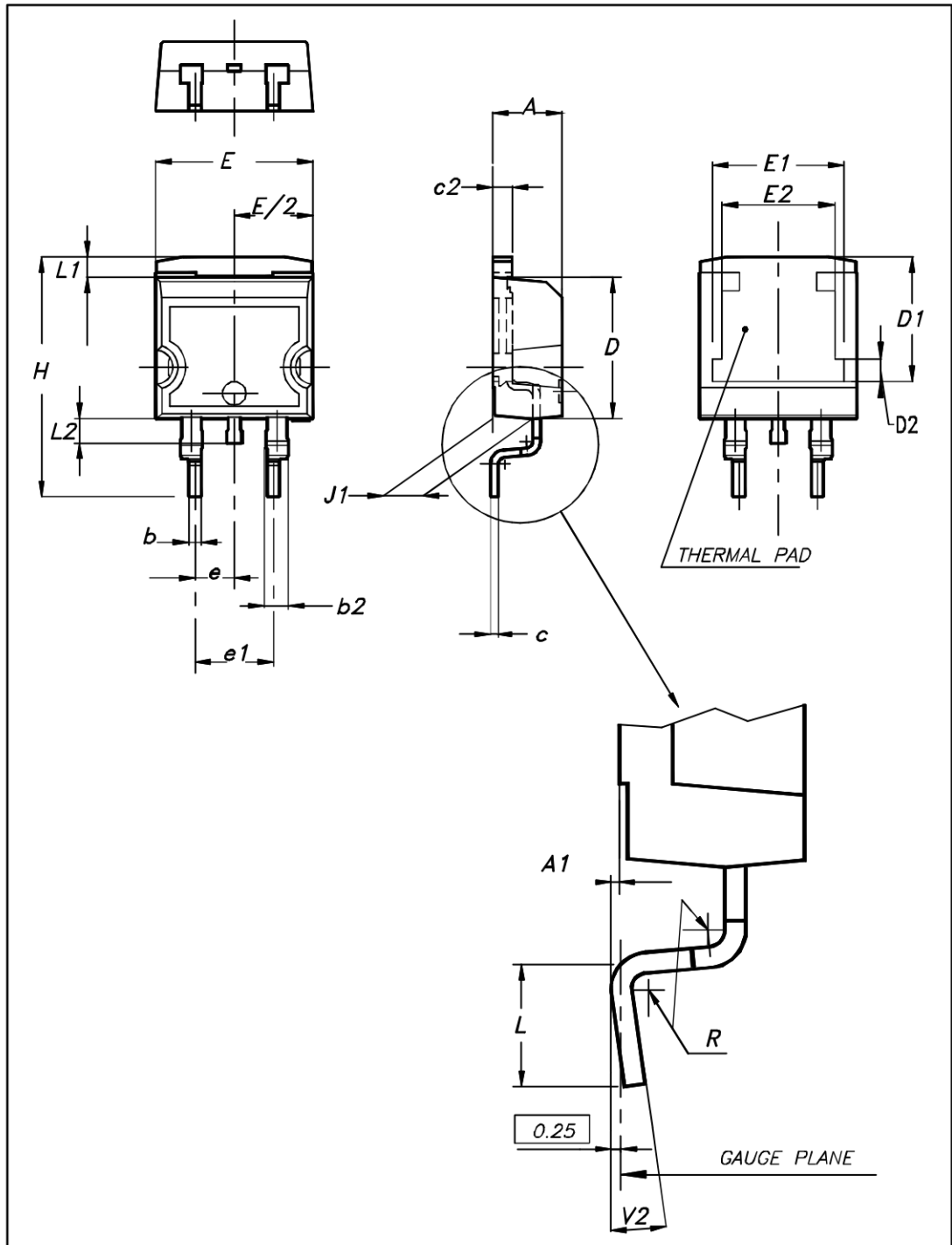

This package drawing may slightly differ from the physical package. However, all the specified dimensions are guaranteed.

Table 5: D<sup>2</sup>PAK package mechanical data

Ref.	Dimensions			
	Millimeters		Inches	
	Min.	Max.	Min.	Max.
A	4.36	4.60	0.172	0.181
A1	0.00	0.25	0.000	0.010
b	0.70	0.93	0.028	0.037
b2	1.14	1.70	0.045	0.067
c	0.38	0.69	0.015	0.027
c2	1.19	1.36	0.047	0.053
D	8.60	9.35	0.339	0.368
D1	6.90	8.00	0.272	0.311
D2	1.10	1.50	0.043	0.060
E	10.00	10.55	0.394	0.415
E1	8.10	8.90	0.319	0.346
E2	6.85	7.25	0.266	0.282
e	2.54 typ.		0.100	
e1	4.88	5.28	0.190	0.205
H	15.00	15.85	0.591	0.624
J1	2.49	2.90	0.097	0.112
L	1.90	2.79	0.075	0.110
L1	1.27	1.65	0.049	0.065
L2	1.30	1.78	0.050	0.070
R	0.4 typ.		0.015	
V2	0°	8°	0°	8°

Figure 12: D<sup>2</sup>PAK recommended footprint (dimensions in mm)

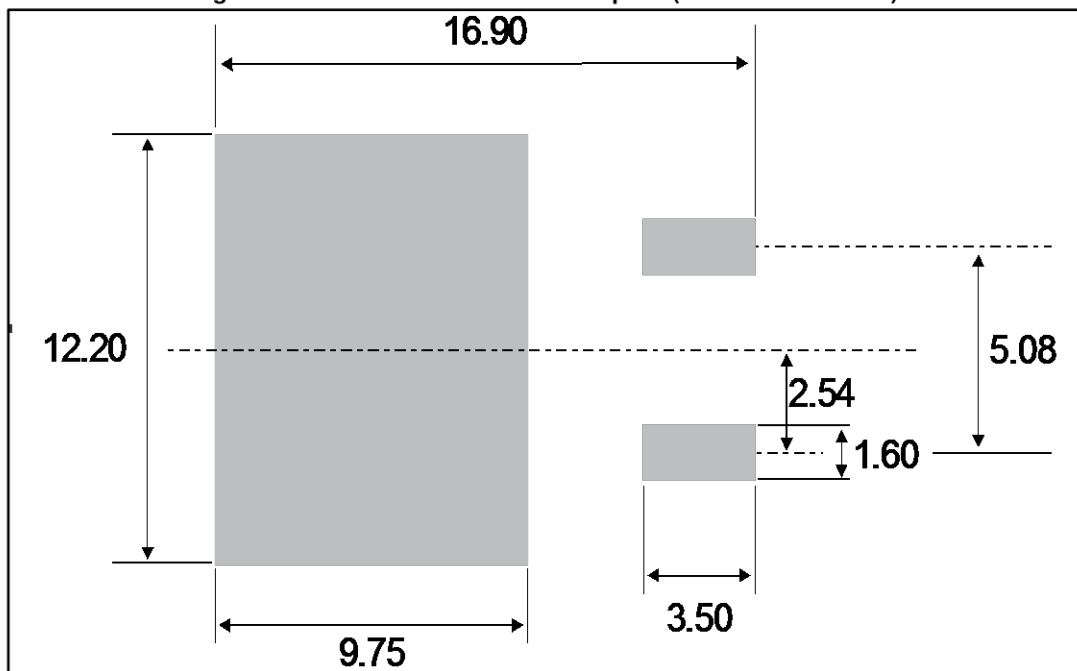



## 2.2 TO-220AC package information

Figure 13: TO-220AC package outline

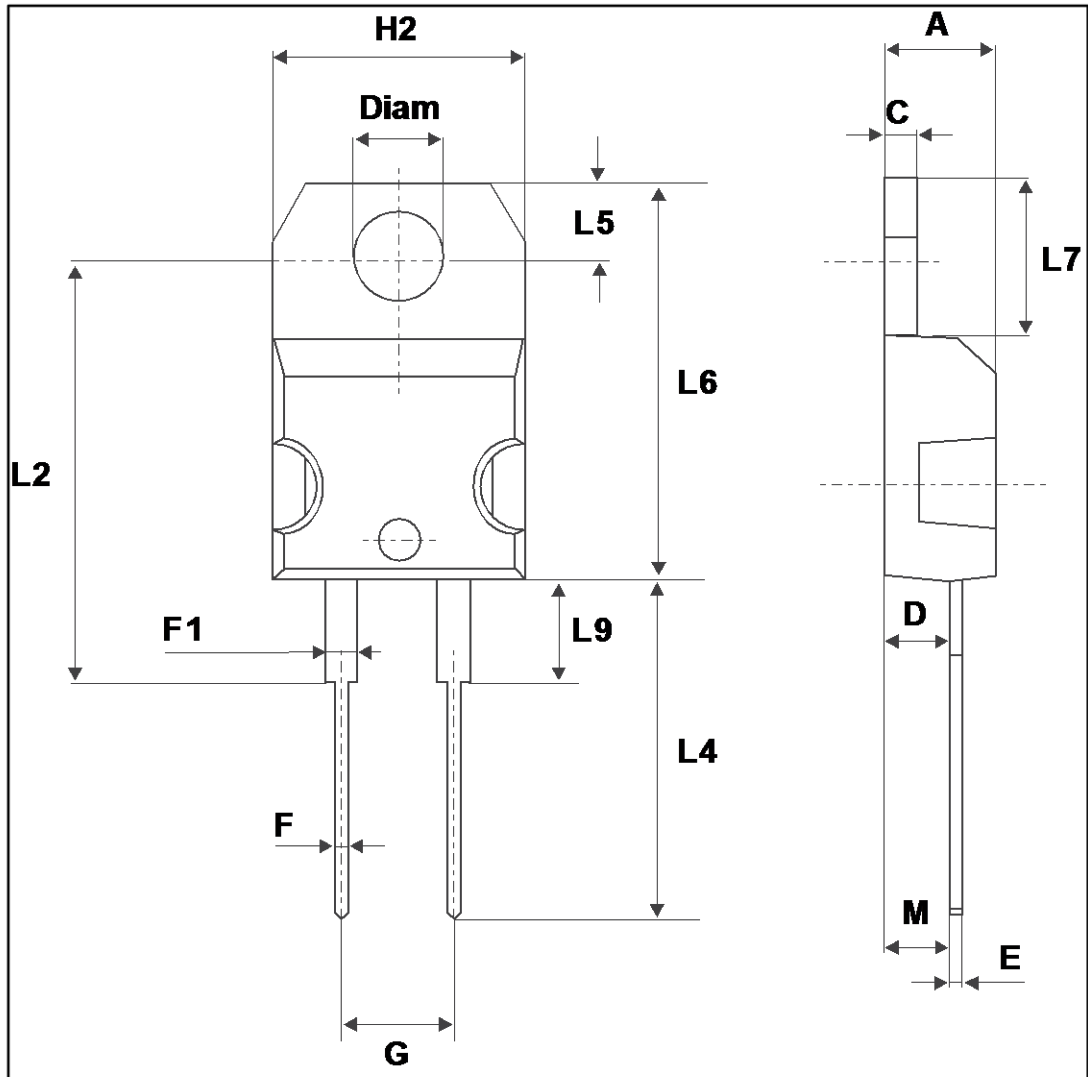

Table 6: TO-220AC package mechanical data

Ref.	Dimensions			
	Millimeters		Inches	
	Min.	Max.	Min.	Max.
A	4.40	4.60	0.173	0.181
C	1.23	1.32	0.048	0.051
D	2.40	2.72	0.094	0.107
E	0.49	0.70	0.019	0.027
F	0.61	0.88	0.024	0.034
F1	1.14	1.70	0.044	0.066
G	4.95	5.15	0.194	0.202
H2	10.00	10.40	0.393	0.409
L2	16.40 typ.		0.645 typ.	
L4	13.00	14.00	0.511	0.551
L5	2.65	2.95	0.104	0.116
L6	15.25	15.75	0.600	0.620
L7	6.20	6.60	0.244	0.259
L9	3.50	3.93	0.137	0.154
M	2.6 typ.		0.102 typ.	
Diam	3.75	3.85	0.147	0.151

### 2.3 TO-220FPAC package information

Figure 14: TO-220FPAC package outline

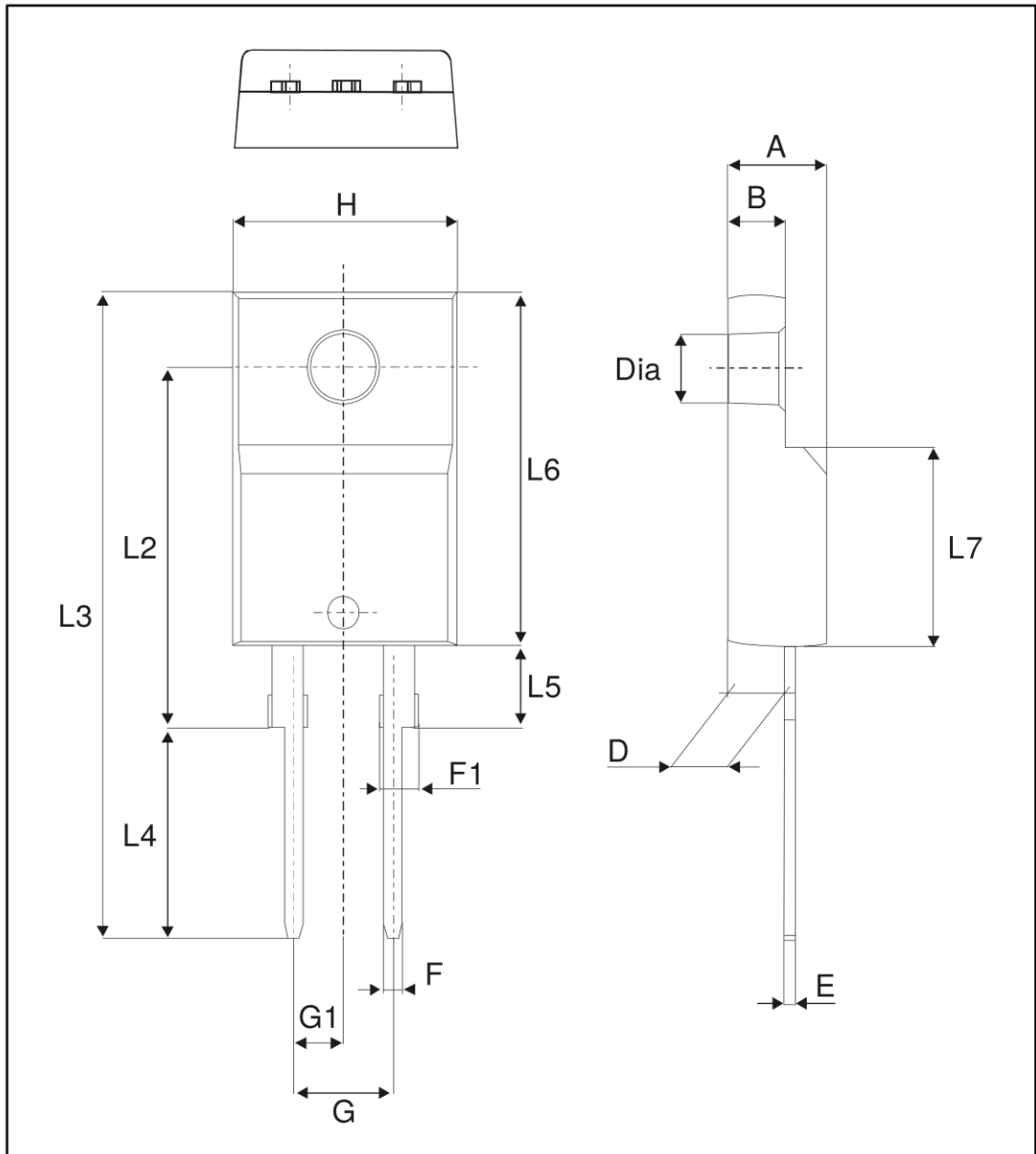

Table 7: TO-220FPAC package mechanical data

Ref.	Dimensions			
	Millimeters		Inches	
	Min.	Max.	Min.	Max.
A	4.4	4.6	0.173	0.181
B	2.5	2.7	0.098	0.106
D	2.5	2.75	0.098	0.108
E	0.45	0.70	0.018	0.027
F	0.75	1	0.030	0.039
F1	1.15	1.70	0.045	0.067
G	4.95	5.20	0.195	0.205
G1	2.4	2.7	0.094	0.106
H	10	10.4	0.393	0.409
L2	16 typ.		0.63 typ.	
L3	28.6	30.6	0.126	1.205
L4	9.8	10.6	0.386	0.417
L5	2.9	3.6	0.114	0.142
L6	15.9	16.4	0.626	0.646
L7	9.00	9.30	0.354	0.366
Dia.	3.00	3.20	0.118	0.126

### 3 Ordering information

Table 8: Ordering information

Order code	Marking	Package	Weight	Base qty	Delivery mode
STPS8H100D	STPS8H100D	TO-220AC	1.86g	50	Tube
STPS8H100FP	STPS8H100FP	TO-220FPAC	1.90g	50	Tube
STPS8H100G	STPS8H100G	D <sup>2</sup> PAK	1.48g	50	Tube
STPS8H100G-TR	STPS8H100G	D <sup>2</sup> PAK	1.48g	1000	Tape and reel

### 4 Revision history

Table 9: Document revision history

Date	Revision	Changes
Jul-2003	6D	Last update.
01-Jun-2006	10	Reformatted to current standard. Added ECOPACK statement. Changed nF to pF in Figure 11. Revision number set to 10 to align with on-line versioning.
08-Apr-2014	11	Updated D <sup>2</sup> PAK package information and Figure 2.
14-Dec-2015	12	Updated features in cover page. Minor text changes in <a href="#">Section 1: "Characteristics"</a> . Updated <a href="#">Section 2: "Package information"</a> .

**IMPORTANT NOTICE – PLEASE READ CAREFULLY**

STMicroelectronics NV and its subsidiaries ("ST") reserve the right to make changes, corrections, enhancements, modifications, and improvements to ST products and/or to this document at any time without notice. Purchasers should obtain the latest relevant information on ST products before placing orders. ST products are sold pursuant to ST's terms and conditions of sale in place at the time of order acknowledgement.

Purchasers are solely responsible for the choice, selection, and use of ST products and ST assumes no liability for application assistance or the design of Purchasers' products.

No license, express or implied, to any intellectual property right is granted by ST herein.

Resale of ST products with provisions different from the information set forth herein shall void any warranty granted by ST for such product.

ST and the ST logo are trademarks of ST. All other product or service names are the property of their respective owners.

Information in this document supersedes and replaces information previously supplied in any prior versions of this document.

© 2015 STMicroelectronics – All rights reserved