

N-channel 800 V, 0.3 Ω typ., 14 A MDmesh™ K5 Power MOSFETs
in D²PAK, TO-220FP, TO-220 and TO-247 packages

Datasheet – production data

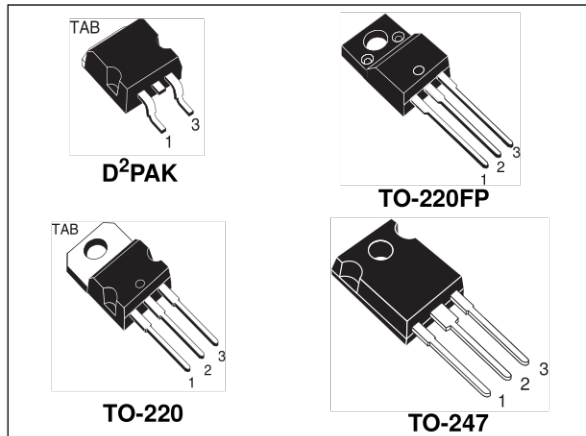
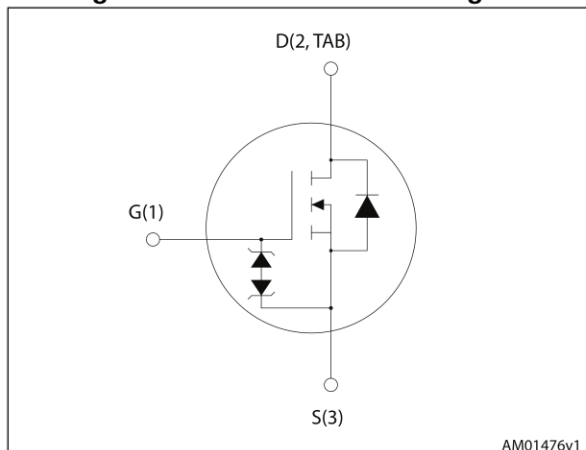

Figure 1. Internal schematic diagram



Features

Order code	V _{DS}	R _{DS(on)max}	I _D	P _{TOT}
STB15N80K5	800 V	0.375 Ω	14 A	190 W
STF15N80K5				35 W
STP15N80K5				190 W
STW15N80K5				190 W

- Industry's lowest R_{DS(on)} x area
- Industry's best figure of merit (FoM)
- Ultra low gate charge
- 100% avalanche tested
- Zener-protected

Applications

- Switching applications

Description

These very high voltage N-channel Power MOSFETs are designed using MDmesh™ K5 technology based on an innovative proprietary vertical structure. The result is a dramatic reduction in on-resistance and ultra-low gate charge for applications requiring superior power density and high efficiency.

Table 1. Device summary

Order code	Marking	Package	Packaging
STB15N80K5	15N80K5	D ² PAK	Tape and reel
STF15N80K5		TO-220FP	Tube
STP15N80K5		TO-220	
STW15N80K5		TO-247	

Contents

- 1 Electrical ratings 3**
- 2 Electrical characteristics 4**
 - 2.1 Electrical characteristics (curves) 6
- 3 Test circuits 9**
- 4 Package mechanical data 10**
 - 4.1 STB15N80K5, D²PAK (TO-263)11
 - 4.2 STP15N80K5, TO-220 14
 - 4.3 STF15N80K5, TO-220FP 16
 - 4.4 STW15N80K5, TO-247 18
- 5 Packaging information 20**
- 6 Revision history 22**



1 Electrical ratings

Table 2. Absolute maximum ratings

Symbol	Parameter	Value		Unit
		D ² PAK, TO-220, TO-247	TO-220FP	
V _{GS}	Gate- source voltage	± 30		V
I _D	Drain current (continuous) at T _C = 25 °C	14	14 ⁽¹⁾	A
I _D	Drain current (continuous) at T _C = 100 °C	8.8	8.8 ⁽¹⁾	A
I _{DM} ⁽²⁾	Drain current (pulsed)	56	56 ⁽¹⁾	A
P _{TOT}	Total dissipation at T _C = 25 °C	190	35	W
I _{AR}	Max current during repetitive or single pulse avalanche (pulse width limited by T _{jmax})	4		A
E _{AS}	Single pulse avalanche energy (starting T _J = 25 °C, I _D =I _{AS} , V _{DD} = 50 V)	150		mJ
V _{iso}	Insulation withstand voltage (RMS) from all three leads to external heat sink (t=1 s; T _C =25 °C)	2500		V
dv/dt ⁽³⁾	Peak diode recovery voltage slope	4.5		V/ns
T _j T _{stg}	Operating junction temperature Storage temperature	-55 to 150		°C

- Limited by package.
- Pulse width limited by safe operating area.
- I_{SD} ≤ 14 A, di/dt ≤ 100 A/μs, V_{Peak} ≤ V_{(BR)DSS}

Table 3. Thermal data

Symbol	Parameter	Value				Unit
		TO-220	TO-247	D ² PAK	TO-220FP	
R _{thj-case}	Thermal resistance junction-case max	0.66			3.6	°C/W
R _{thj-amb}	Thermal resistance junction-amb max	62.5	50		62.5	
R _{thj-pcb} ⁽¹⁾	Thermal resistance junction-pcb max			30		

- When mounted on 1inch² FR-4 board, 2 oz Cu.

2 Electrical characteristics

($T_{CASE} = 25\text{ °C}$ unless otherwise specified).

Table 4. On/off states

Symbol	Parameter	Test conditions	Min.	Typ.	Max.	Unit
$V_{(BR)DSS}$	Drain-source breakdown voltage ($V_{GS} = 0$)	$I_D = 1\text{ mA}$	800			V
I_{DSS}	Zero gate voltage drain current ($V_{GS} = 0$)	$V_{DS} = 800\text{ V}$			1	μA
		$V_{DS} = 800\text{ V}, T_c = 125\text{ °C}$			50	μA
I_{GSS}	Gate body leakage current ($V_{DS} = 0$)	$V_{GS} = \pm 20\text{ V}$			± 10	μA
$V_{GS(th)}$	Gate threshold voltage	$V_{DS} = V_{GS}, I_D = 100\text{ }\mu\text{A}$	3	4	5	V
$R_{DS(on)}$	Static drain-source on resistance	$V_{GS} = 10\text{ V}, I_D = 7\text{ A}$		0.3	0.375	Ω

Table 5. Dynamic

Symbol	Parameter	Test conditions	Min.	Typ.	Max.	Unit
C_{iss}	Input capacitance	$V_{DS} = 100\text{ V}, f = 1\text{ MHz}, V_{GS} = 0$	-	1100	-	pF
C_{oss}	Output capacitance		-	85	-	pF
C_{rss}	Reverse transfer capacitance		-	1.5	-	pF
$C_{o(tr)}^{(1)}$	Equivalent capacitance time related	$V_{GS} = 0, V_{DS} = 0\text{ to }640\text{ V}$	-	113	-	pF
$C_{o(er)}^{(2)}$	Equivalent capacitance energy related		-	49	-	pF
R_G	Intrinsic gate resistance	$f = 1\text{ MHz}, I_D = 0$	-	4.5	-	Ω
Q_g	Total gate charge	$V_{DD} = 640\text{ V}, I_D = 14\text{ A}$ $V_{GS} = 10\text{ V}$ (see Figure 20)	-	32	-	nC
Q_{gs}	Gate-source charge		-	6	-	nC
Q_{gd}	Gate-drain charge		-	22	-	nC

1. Time related is defined as a constant equivalent capacitance giving the same charging time as C_{oss} when V_{DS} increases from 0 to 80% V_{DSS}
2. Energy related is defined as a constant equivalent capacitance giving the same stored energy as C_{oss} when V_{DS} increases from 0 to 80% V_{DSS}

Table 6. Switching times

Symbol	Parameter	Test conditions	Min.	Typ.	Max.	Unit
$t_{d(on)}$	Turn-on delay time	$V_{DD} = 400\text{ V}$, $I_D = 7\text{ A}$, $R_G = 4.7\ \Omega$, $V_{GS} = 10\text{ V}$ (see Figure 19 and 24)	-	19	-	ns
t_r	Rise time		-	17.6	-	ns
$t_{d(off)}$	Turn-off delay time		-	44	-	ns
t_f	Fall time		-	10	-	ns

Table 7. Source drain diode

Symbol	Parameter	Test conditions	Min.	Typ.	Max.	Unit
I_{SD}	Source-drain current		-		14	A
I_{SDM}	Source-drain current (pulsed)		-		56	A
$V_{SD}^{(1)}$	Forward on voltage	$I_{SD} = 14\text{ A}$, $V_{GS} = 0$	-		1.5	V
t_{rr}	Reverse recovery time	$I_{SD} = 14\text{ A}$, $V_{DD} = 60\text{ V}$ $di/dt = 100\text{ A}/\mu\text{s}$, (see Figure 21)	-	445		ns
Q_{rr}	Reverse recovery charge		-	8.2		μC
I_{RRM}	Reverse recovery current		-	37		A
t_{rr}	Reverse recovery time	$I_{SD} = 14\text{ A}$, $V_{DD} = 60\text{ V}$ $di/dt = 100\text{ A}/\mu\text{s}$, $T_J = 150\text{ }^\circ\text{C}$ (see Figure 21)	-	580		ns
Q_{rr}	Reverse recovery charge		-	10		μC
I_{RRM}	Reverse recovery current		-	35		A

1. Pulsed: pulse duration = 300 μs , duty cycle 1.5%

Table 8. Gate-source Zener diode

Symbol	Parameter	Test conditions	Min.	Typ.	Max	Unit
$V_{(BR)GSO}$	Gate-source breakdown voltage	$I_{GS} = \pm 1\text{ mA}$, $I_D = 0$	30	-	-	V

The built-in back-to-back Zener diodes have been specifically designed to enhance the ESD capability of the device. The Zener voltage is appropriate for efficient and cost-effective intervention to protect the device integrity. These integrated Zener diodes thus eliminate the need for external components.

2.1 Electrical characteristics (curves)

Figure 2. Safe operating area for D²PAK and TO-220

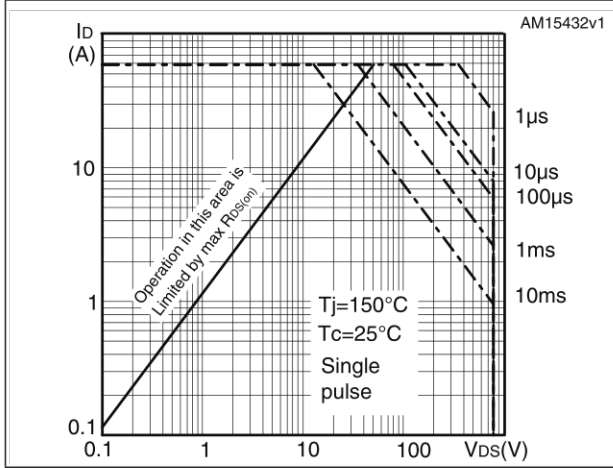

Figure 3. Thermal impedance for D²PAK and TO-220

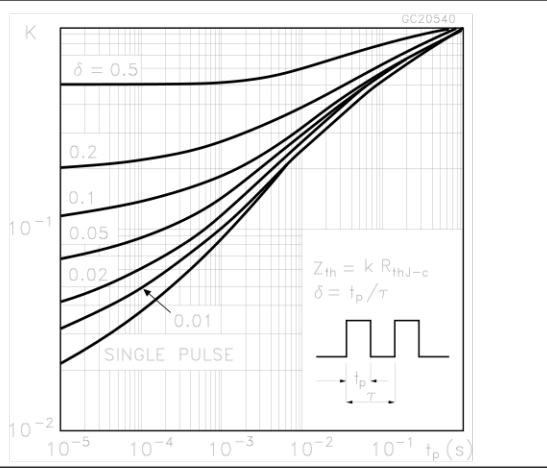

Figure 4. Safe operating area for TO-220FP

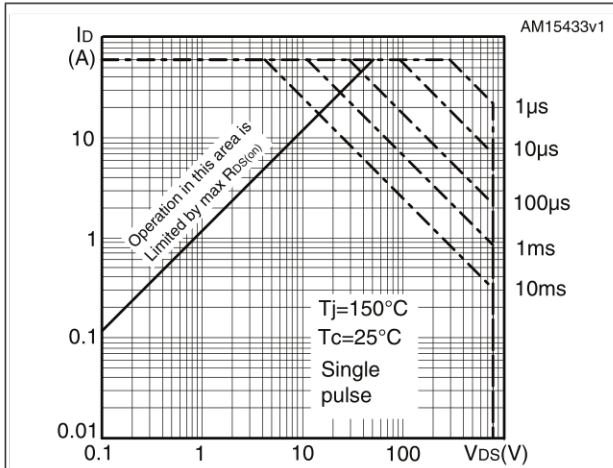

Figure 5. Thermal impedance for TO-220FP

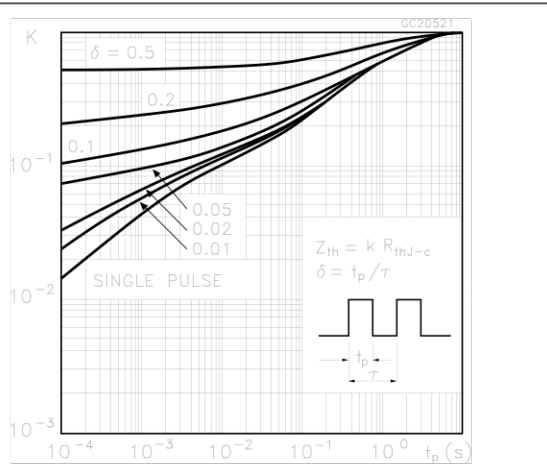

Figure 6. Safe operating area for TO-247

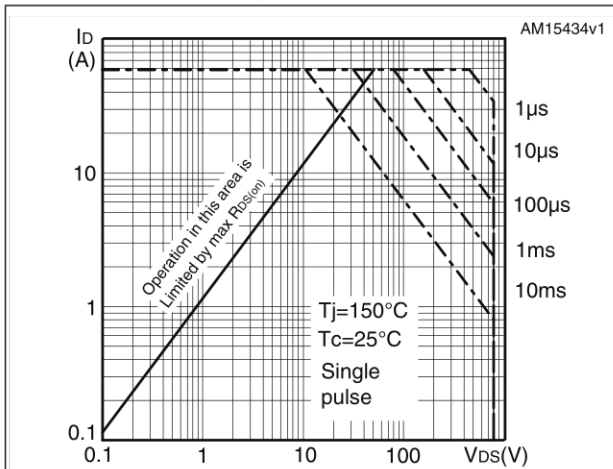

Figure 7. Thermal impedance for TO-247

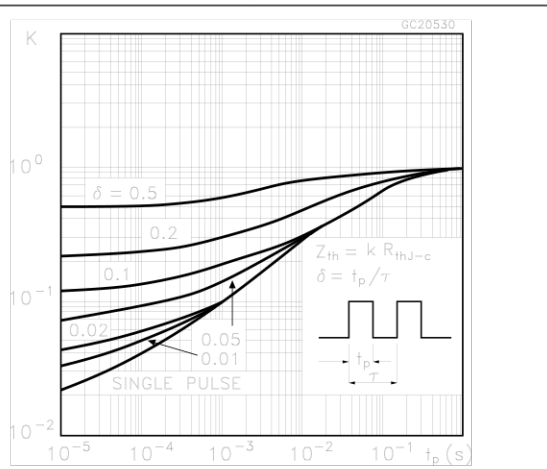

Figure 8. Output characteristics

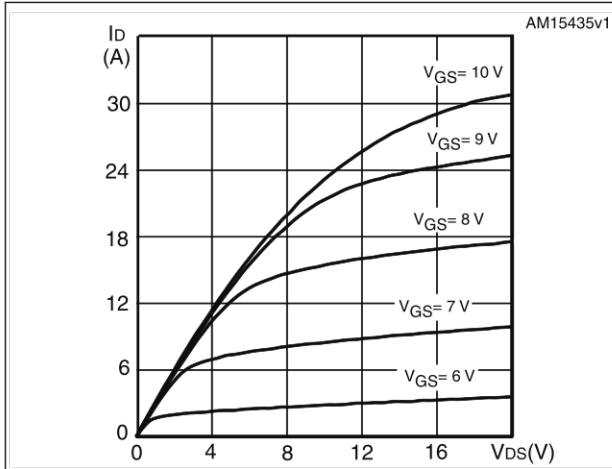

Figure 9. Transfer characteristics

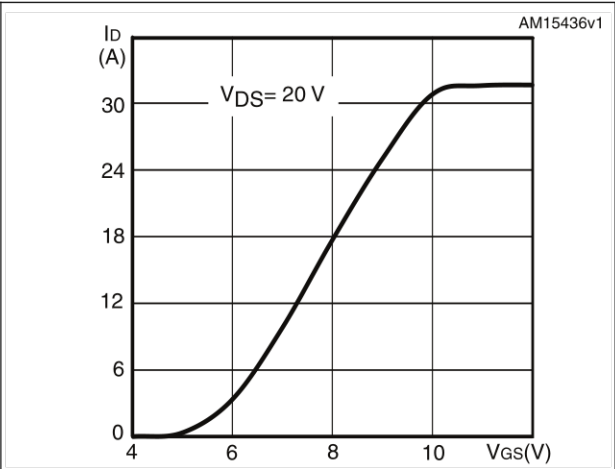

Figure 10. Gate charge vs gate-source voltage

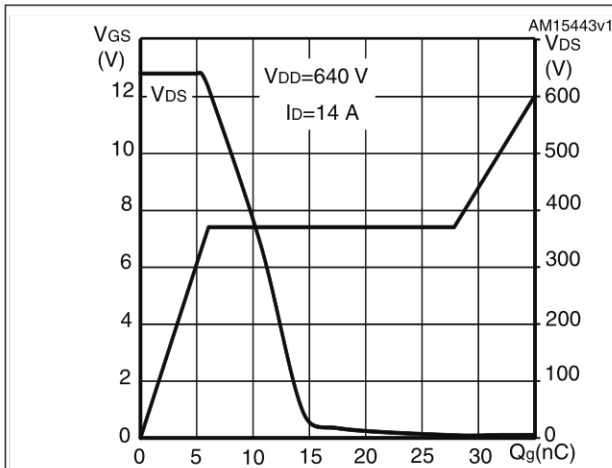

Figure 11. Static drain-source on-resistance

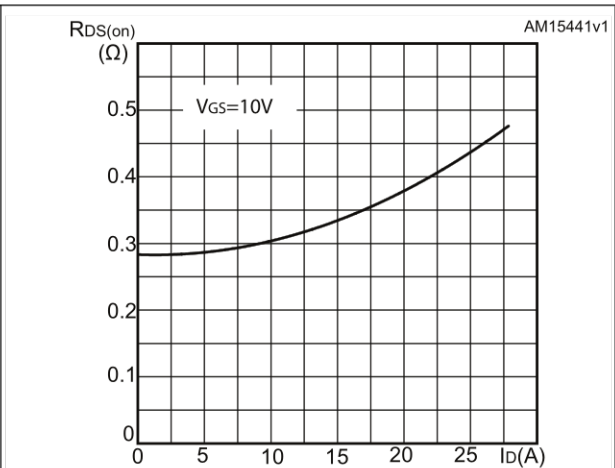

Figure 12. Capacitance variations

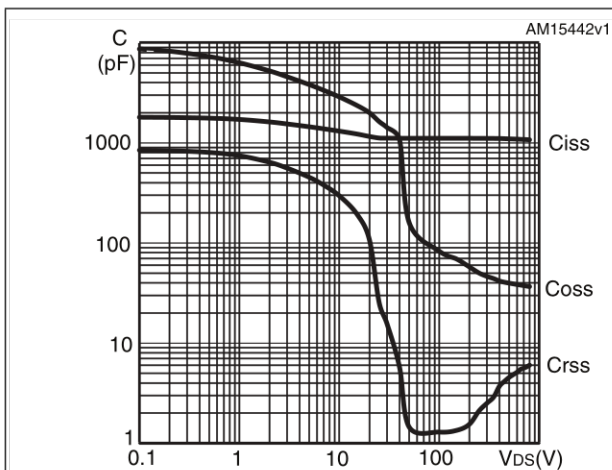

Figure 13. Source-drain diode forward characteristics

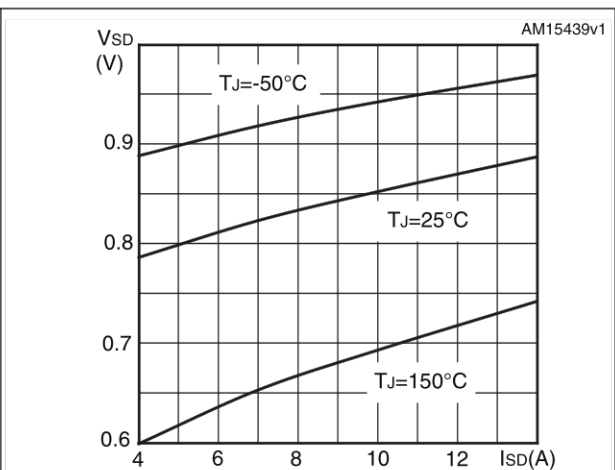

Figure 14. Normalized gate threshold voltage vs temperature

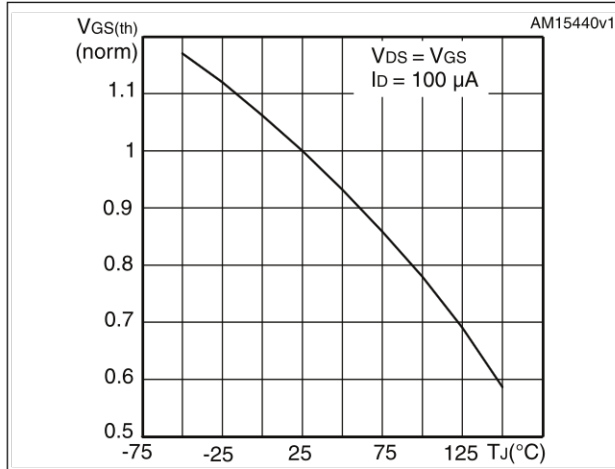

Figure 15. Normalized on-resistance vs temperature

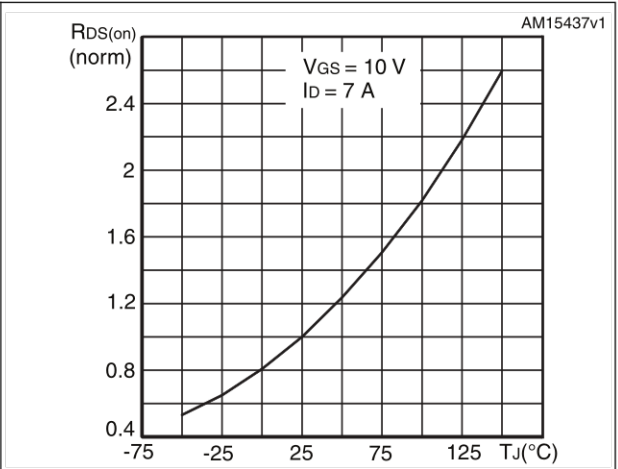

Figure 16. Output capacitance stored energy

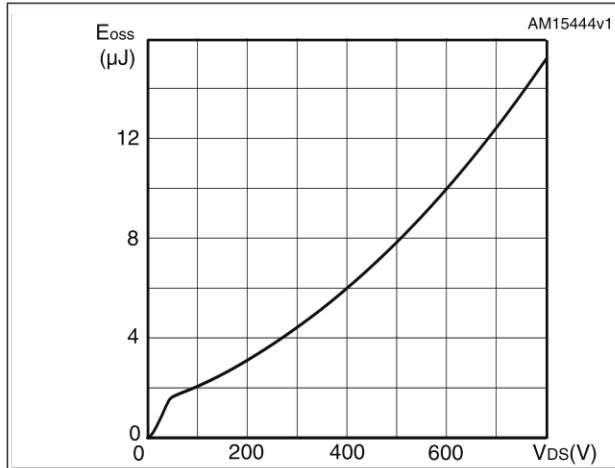

Figure 17. Normalized V_{DS} vs temperature

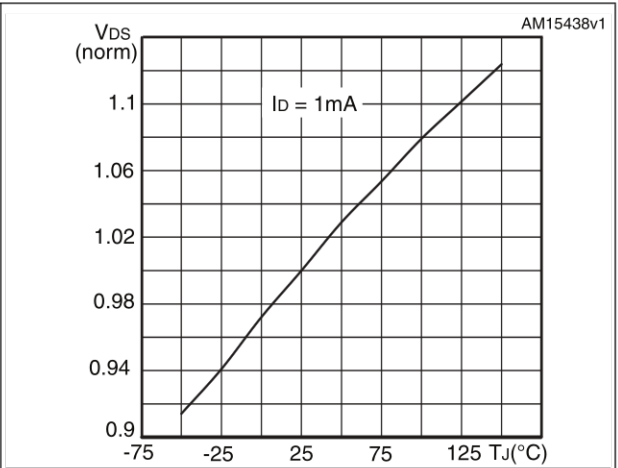
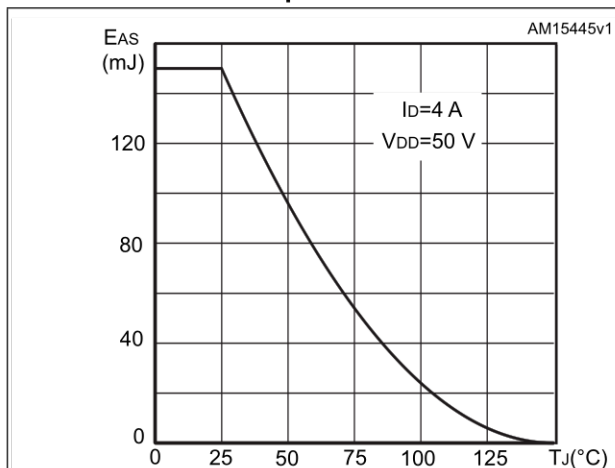
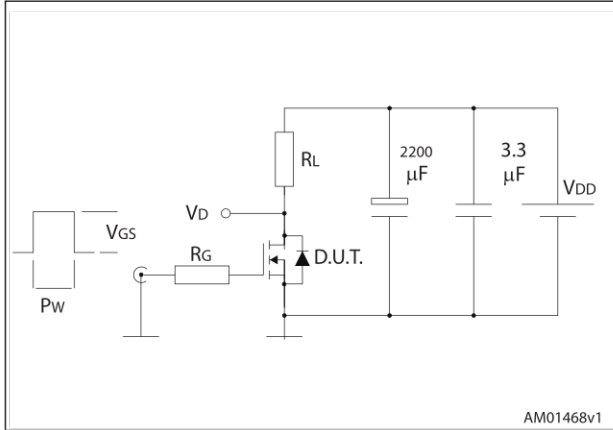

Figure 18. Maximum avalanche energy vs temperature



3 Test circuits

Figure 19. Switching times test circuit for resistive load



AM01468v1

Figure 20. Gate charge test circuit

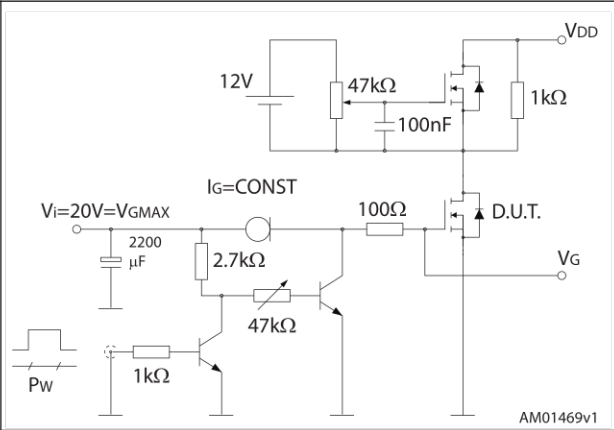

AM01469v1

Figure 21. Test circuit for inductive load switching and diode recovery times

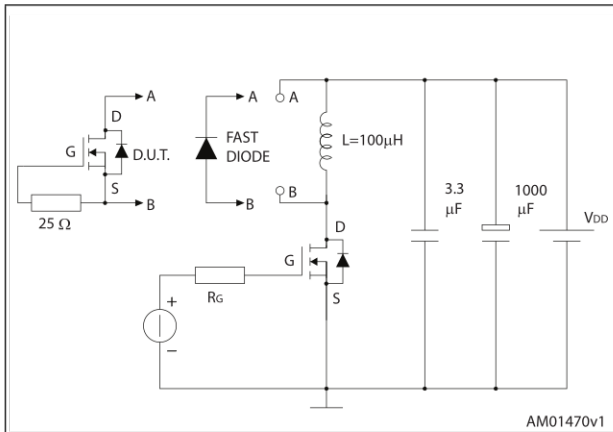

AM01470v1

Figure 22. Unclamped inductive load test circuit

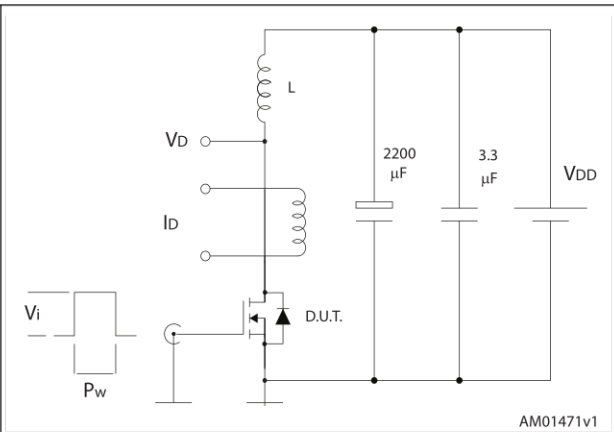

AM01471v1

Figure 23. Unclamped inductive waveform

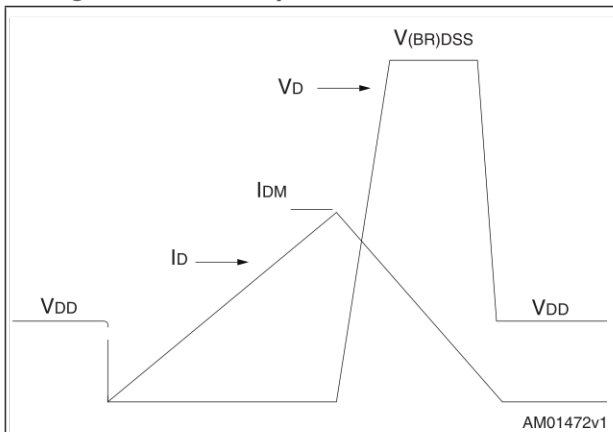

AM01472v1

Figure 24. Switching time waveform

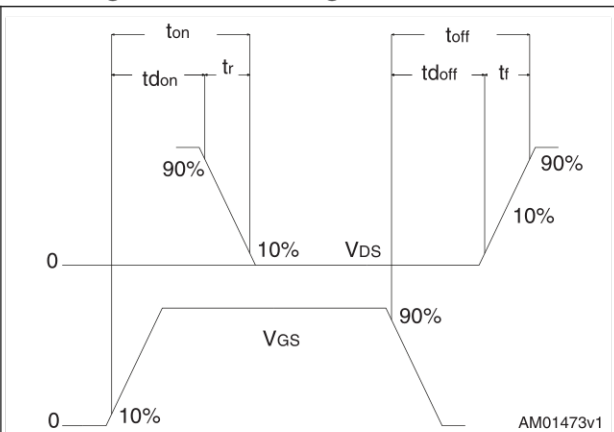

AM01473v1

4 Package mechanical data

In order to meet environmental requirements, ST offers these devices in different grades of ECOPACK[®] packages, depending on their level of environmental compliance. ECOPACK[®] specifications, grade definitions and product status are available at: www.st.com. ECOPACK[®] is an ST trademark.

4.1 STB15N80K5, D²PAK (TO-263)

Figure 25. D²PAK (TO-263) drawing

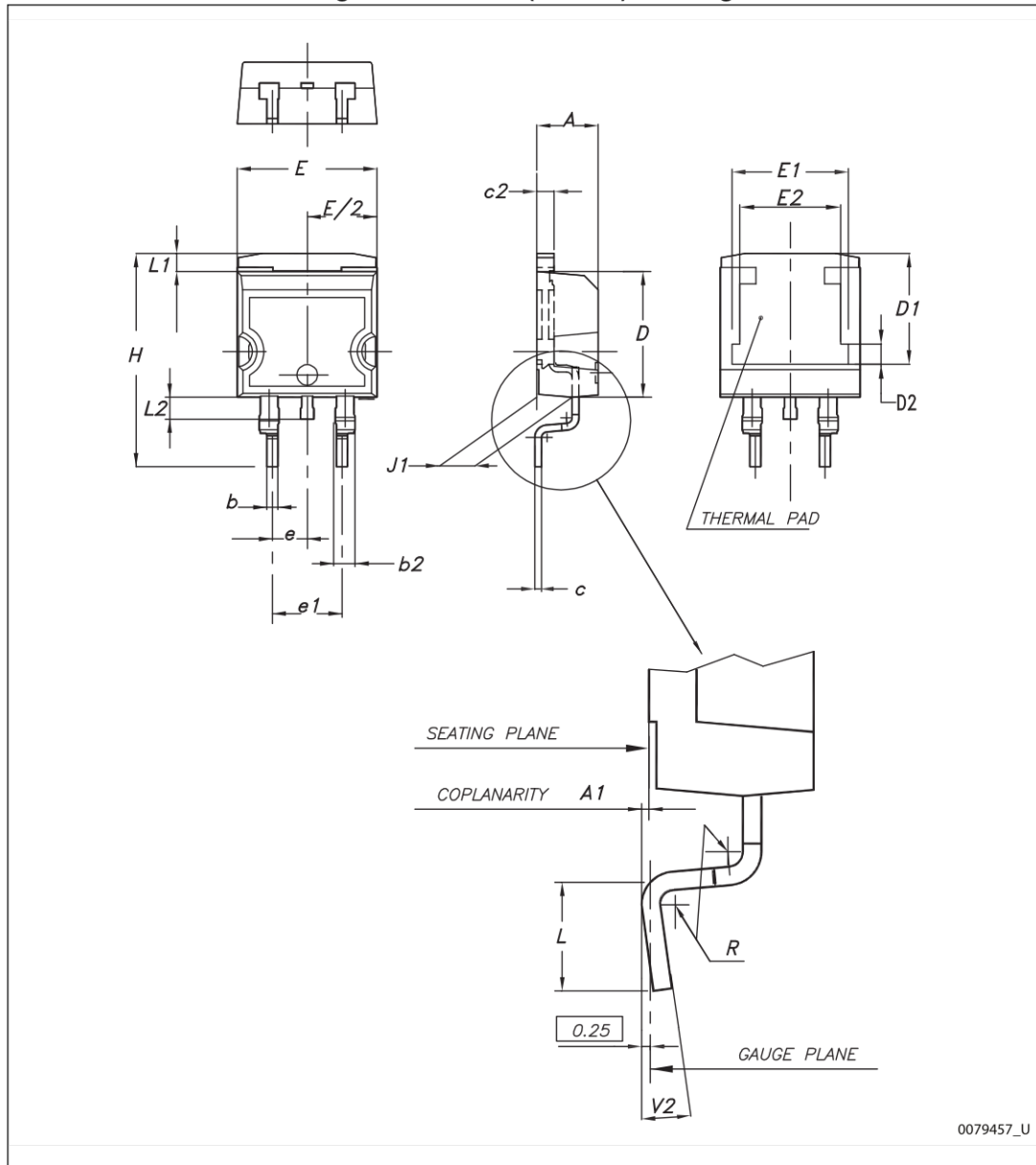
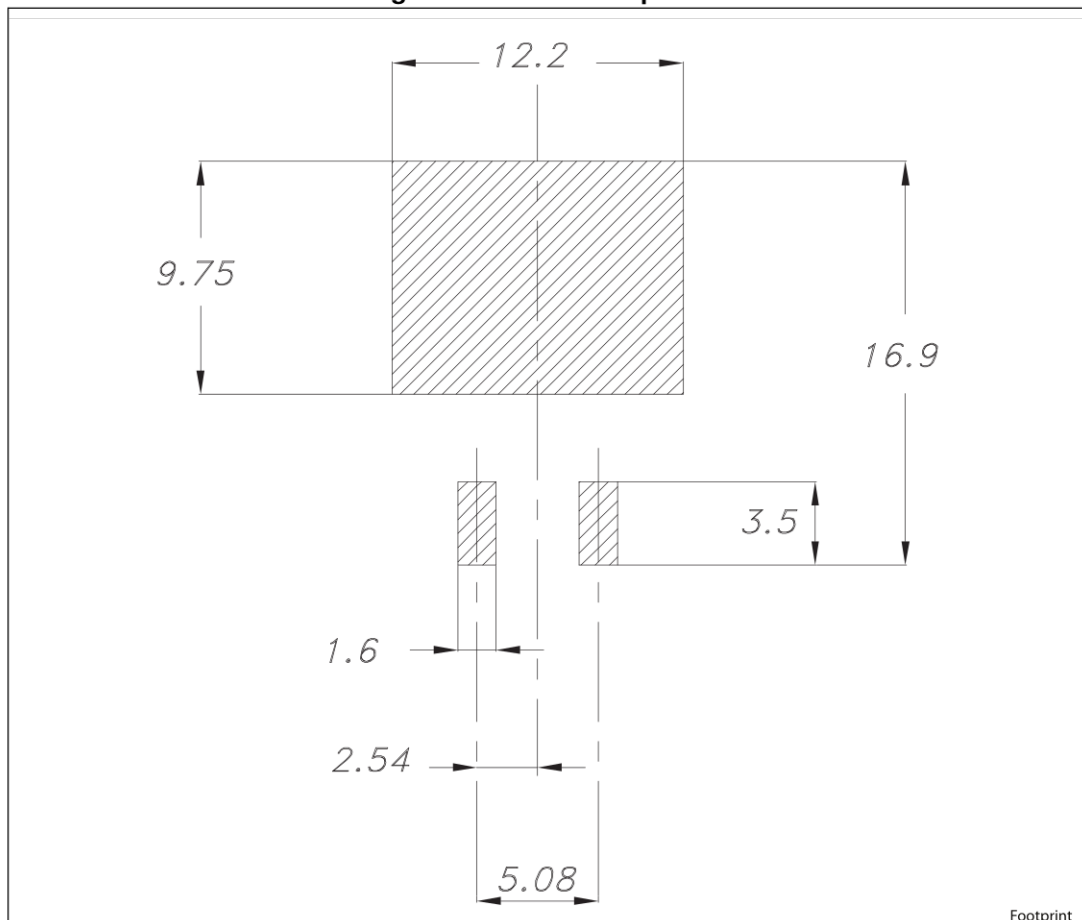

Table 9. D²PAK (TO-263) mechanical data

Dim.	mm		
	Min.	Typ.	Max.
A	4.40		4.60
A1	0.03		0.23
b	0.70		0.93
b2	1.14		1.70
c	0.45		0.60
c2	1.23		1.36
D	8.95		9.35
D1	7.50	7.75	8.00
D2	1.10	1.30	1.50
E	10		10.40
E1	8.50	8.70	8.90
E2	6.85	7.05	7.25
e		2.54	
e1	4.88		5.28
H	15		15.85
J1	2.49		2.69
L	2.29		2.79
L1	1.27		1.40
L2	1.30		1.75
R		0.4	
V2	0°		8°

Figure 26. D²PAK footprint^(a)



a. All dimension are in millimeters

4.2 STP15N80K5, TO-220

Figure 27. TO-220 type A drawing

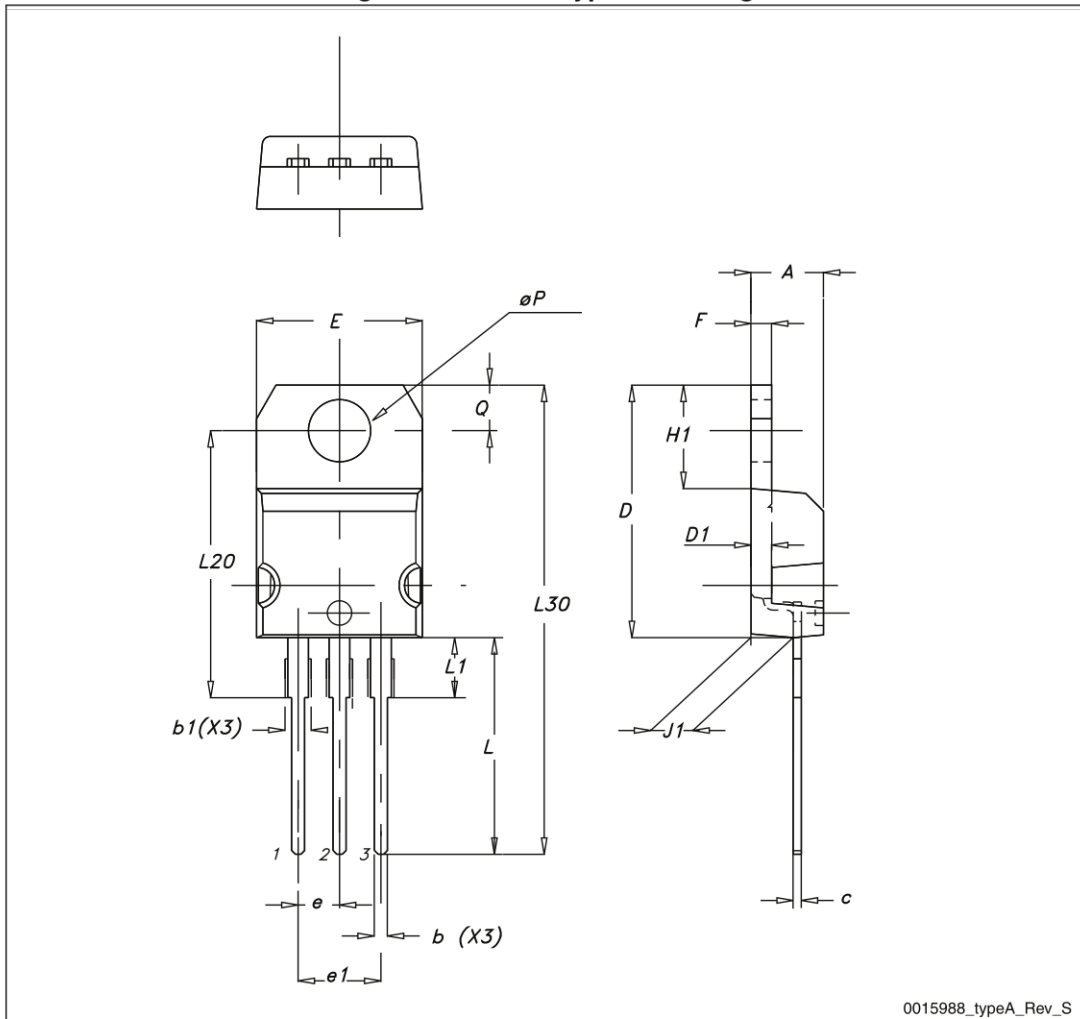
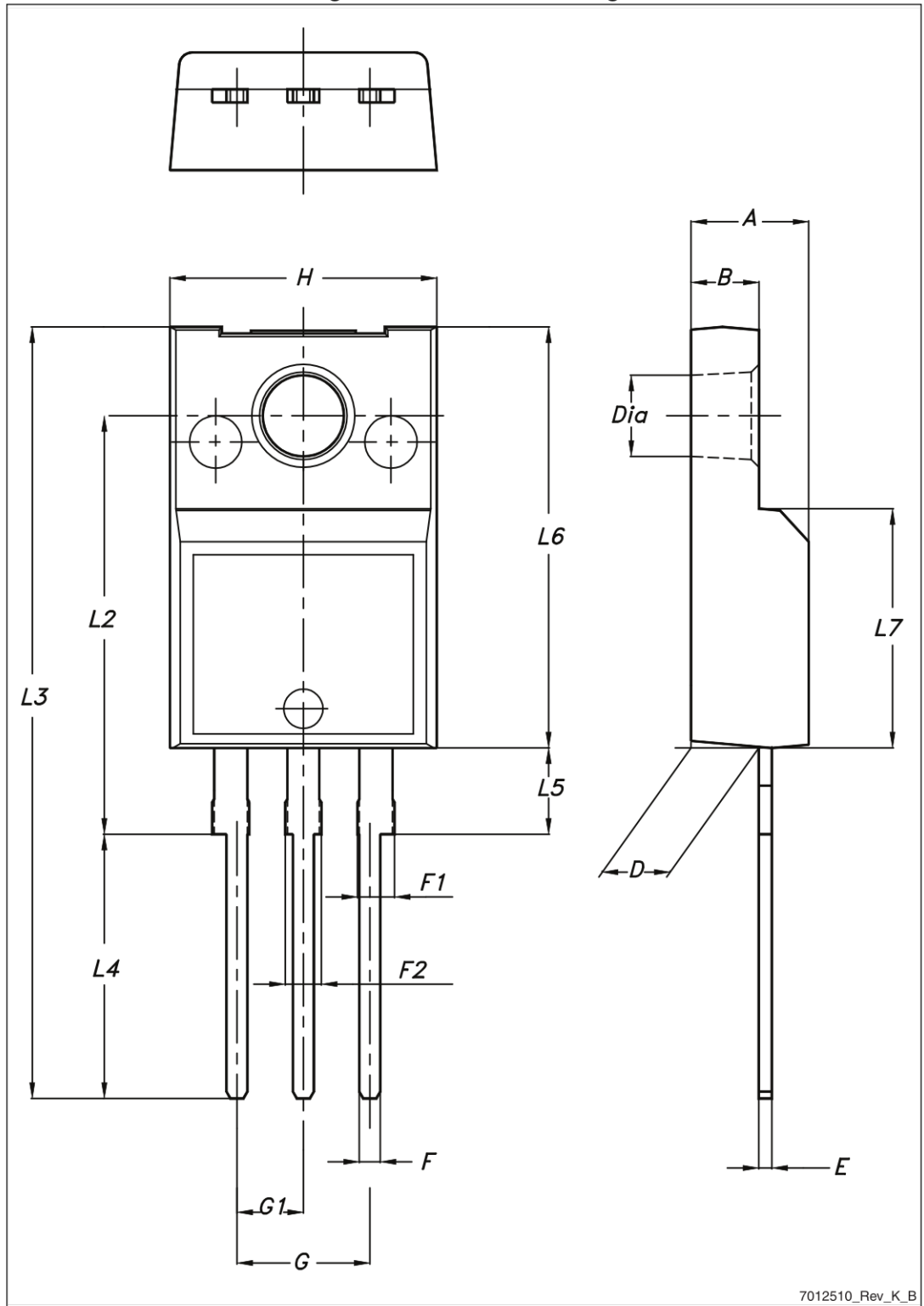

Table 10. TO-220 type A mechanical data

Dim.	mm		
	Min.	Typ.	Max.
A	4.40		4.60
b	0.61		0.88
b1	1.14		1.70
c	0.48		0.70
D	15.25		15.75
D1		1.27	
E	10		10.40
e	2.40		2.70
e1	4.95		5.15
F	1.23		1.32
H1	6.20		6.60
J1	2.40		2.72
L	13		14
L1	3.50		3.93
L20		16.40	
L30		28.90	
ØP	3.75		3.85
Q	2.65		2.95

4.3 STF15N80K5, TO-220FP

Figure 28. TO-220FP drawing



7012510_Rev_K_B

Table 11. TO-220FP mechanical data

Dim.	mm		
	Min.	Typ.	Max.
A	4.4		4.6
B	2.5		2.7
D	2.5		2.75
E	0.45		0.7
F	0.75		1
F1	1.15		1.70
F2	1.15		1.70
G	4.95		5.2
G1	2.4		2.7
H	10		10.4
L2		16	
L3	28.6		30.6
L4	9.8		10.6
L5	2.9		3.6
L6	15.9		16.4
L7	9		9.3
Dia	3		3.2

4.4 STW15N80K5, TO-247

Figure 29. TO-247 drawing

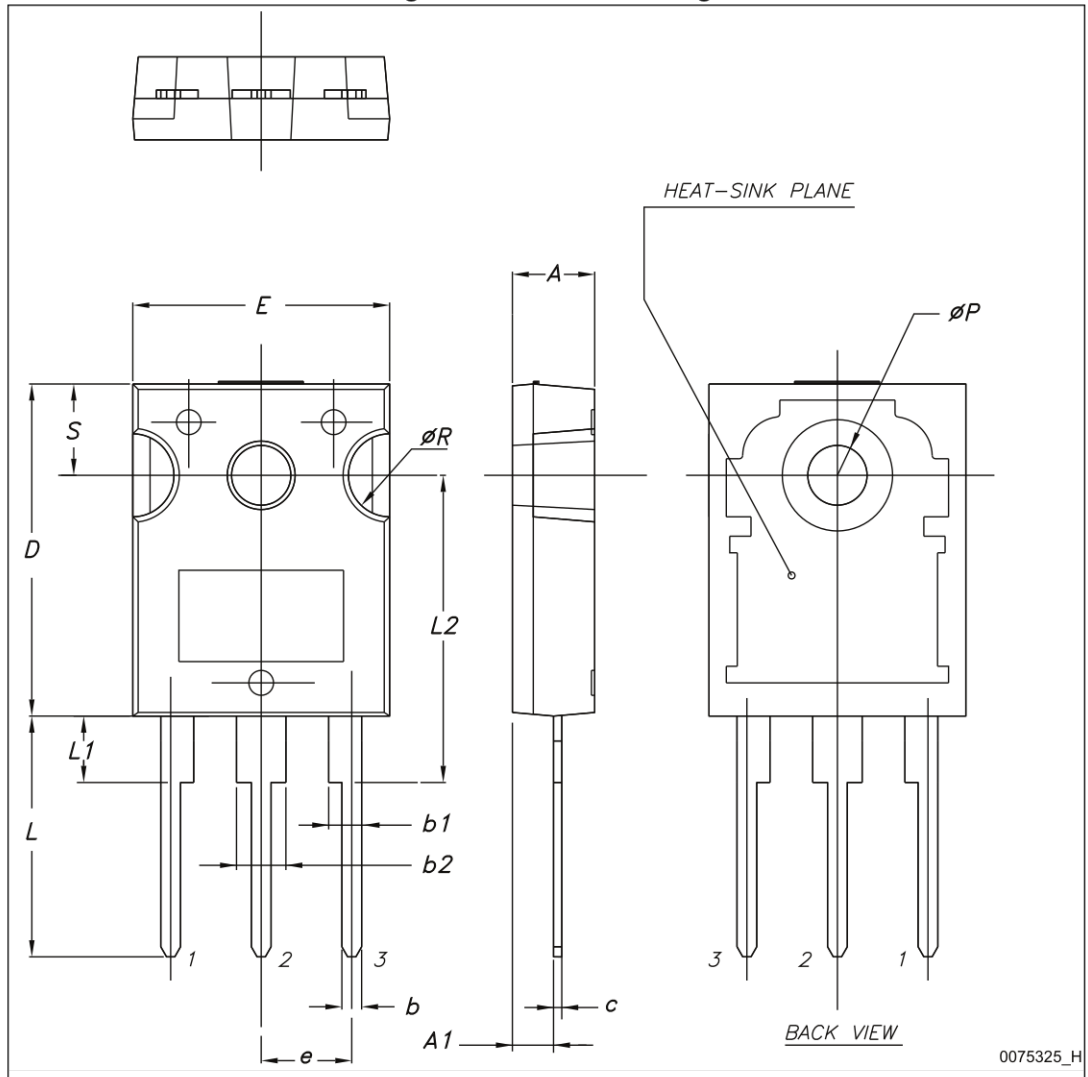

Table 12. TO-247 mechanical data

Dim.	mm.		
	Min.	Typ.	Max.
A	4.85		5.15
A1	2.20		2.60
b	1.0		1.40
b1	2.0		2.40
b2	3.0		3.40
c	0.40		0.80
D	19.85		20.15
E	15.45		15.75
e	5.30	5.45	5.60
L	14.20		14.80
L1	3.70		4.30
L2		18.50	
ØP	3.55		3.65
ØR	4.50		5.50
S	5.30	5.50	5.70

5 Packaging information

Figure 30. Tape

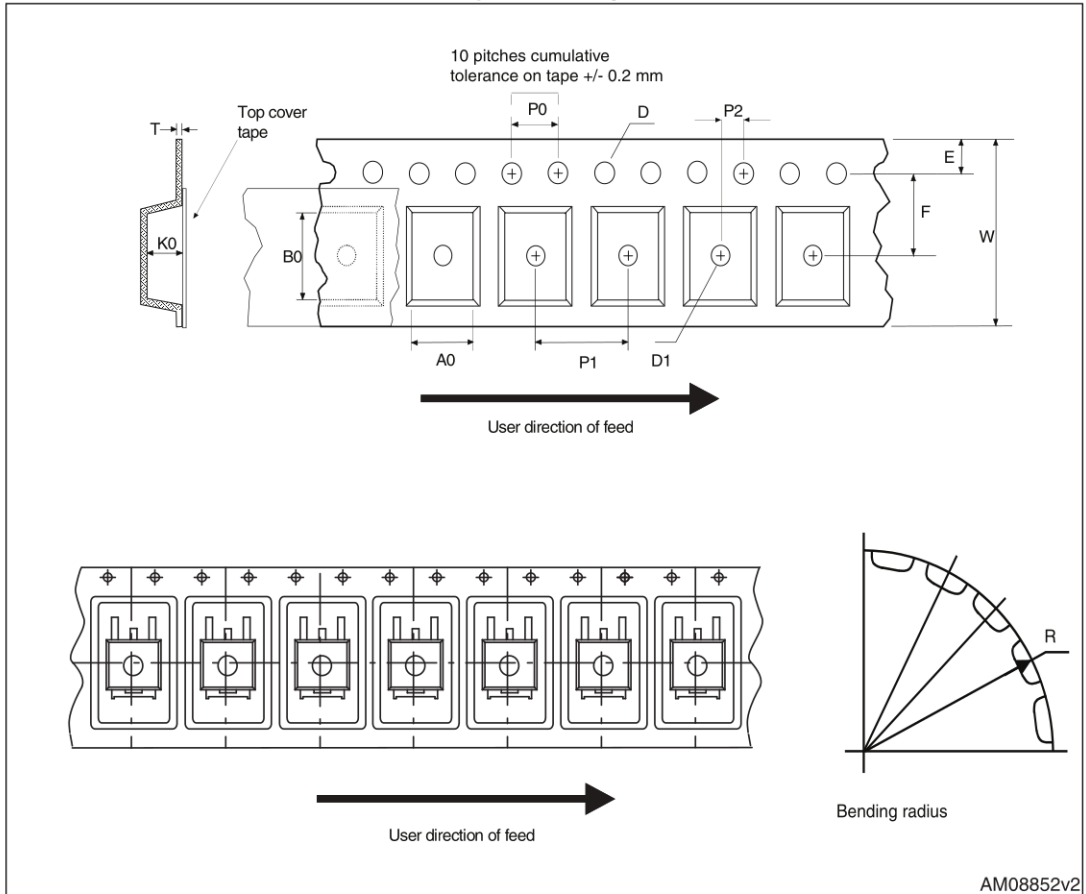

Figure 31. Reel

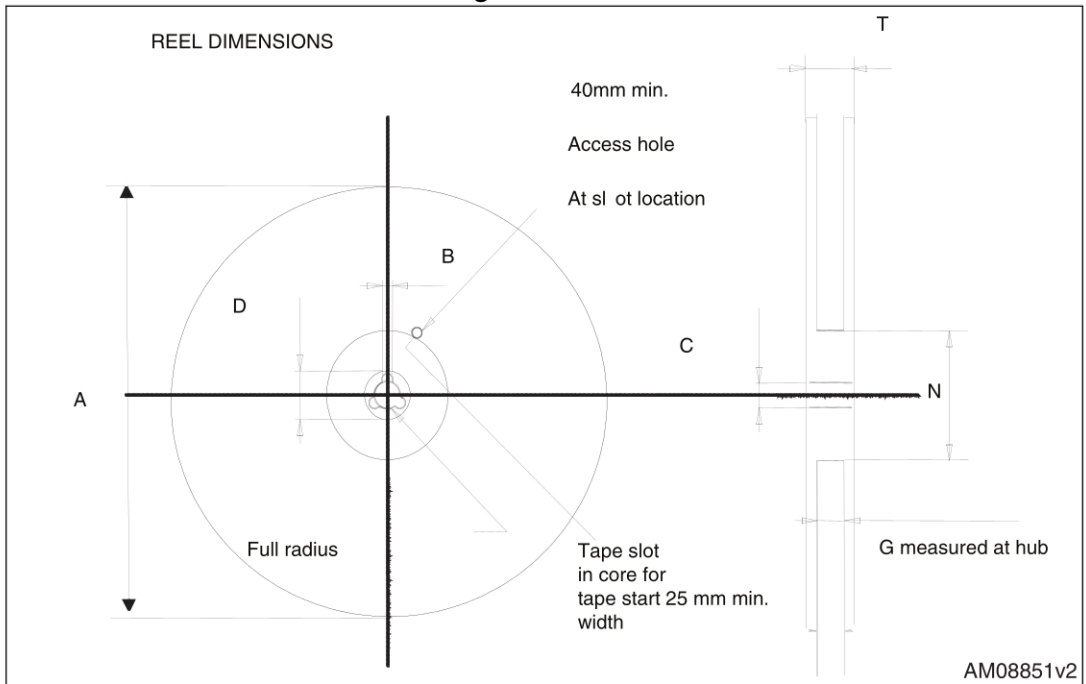

Table 13. D²PAK (TO-263) tape and reel mechanical data

Tape			Reel		
Dim.	mm		Dim.	mm	
	Min.	Max.		Min.	Max.
A0	10.5	10.7	A		330
B0	15.7	15.9	B	1.5	
D	1.5	1.6	C	12.8	13.2
D1	1.59	1.61	D	20.2	
E	1.65	1.85	G	24.4	26.4
F	11.4	11.6	N	100	
K0	4.8	5.0	T		30.4
P0	3.9	4.1			
P1	11.9	12.1	Base qty		1000
P2	1.9	2.1	Bulk qty		1000
R	50				
T	0.25	0.35			
W	23.7	24.3			

6 Revision history

Table 14. Document revision history

Date	Revision	Changes
18-Jul-2012	1	First release.
31-Oct-2012	2	<ul style="list-style-type: none">– Inserted: I_{AR}, E_{AS} and dv/dt values in Table 2– Inserted: Table 5, 6 and 7 typical values– Inserted: Section 2.1: Electrical characteristics (curves)– Minor text changes
31-Oct-2014	3	<p>Updated title, description and features</p> <p>Updated Static drain-source on-resistance</p> <p>Minor text changes</p>

IMPORTANT NOTICE – PLEASE READ CAREFULLY

STMicroelectronics NV and its subsidiaries ("ST") reserve the right to make changes, corrections, enhancements, modifications, and improvements to ST products and/or to this document at any time without notice. Purchasers should obtain the latest relevant information on ST products before placing orders. ST products are sold pursuant to ST's terms and conditions of sale in place at the time of order acknowledgement.

Purchasers are solely responsible for the choice, selection, and use of ST products and ST assumes no liability for application assistance or the design of Purchasers' products.

No license, express or implied, to any intellectual property right is granted by ST herein.

Resale of ST products with provisions different from the information set forth herein shall void any warranty granted by ST for such product.

ST and the ST logo are trademarks of ST. All other product or service names are the property of their respective owners.

Information in this document supersedes and replaces information previously supplied in any prior versions of this document.

© 2014 STMicroelectronics – All rights reserved