

## Sensitive gate 4 A SCRs

Datasheet - production data

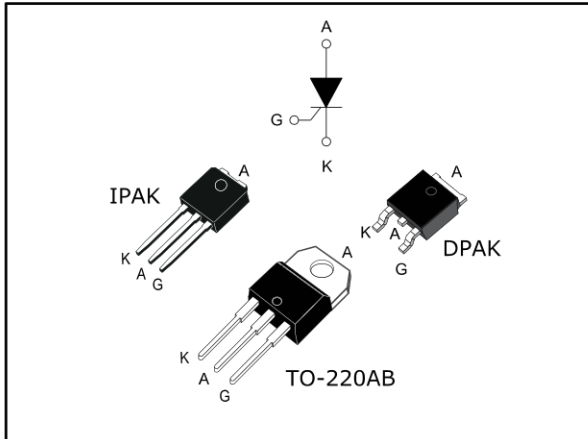

### Description

Thanks to highly sensitive triggering levels, the device is suitable for all applications where the available gate current is limited, such as motor control for hand tools, kitchen aids, overvoltage crowbar protection for low power supplies among others.

Available in through-hole and surface-mount packages, they provide an optimized performance in a limited space area.

**Table 1: Device summary**

Order code	Sensitivity	Package
TS420-600B	0.2 mA	DPAK
TS420-600H		IPAK
TS420-600T		TO-220AB

### Features

- On-state RMS current: 4 A
- Repetitive peak off-state voltage ( $V_{DRM}$ ,  $V_{RRM}$ ) 600 V
- Triggering gate current,  $I_{GT}$  0.2 mA

# 1 Characteristics

**Table 2: Absolute ratings (limiting values)**

Symbol	Parameter		Value	Unit	
$I_{T(RMS)}$	RMS on-state current (180 ° conduction angle)		$T_C = 115^\circ\text{C}$	4	A
$I_{T(AV)}$	Average on-state current (180 ° conduction angle)		$T_C = 115^\circ\text{C}$	2.5	A
$I_{TSM}$	Non repetitive surge peak on-state current	$t_p = 8.3 \text{ ms}$	$T_{j \text{ initial}} = 25^\circ\text{C}$	33	A
		$t_p = 10 \text{ ms}$		30	
$I^2t$	$I^2t$ value for fusing	$t_p = 10 \text{ ms}$	$T_j = 25^\circ\text{C}$	4.5	$\text{A}^2\text{s}$
$di/dt$	Critical rate of rise of on-state current $I_G = 10 \text{ mA}$ , $di_G/dt = 0.1 \text{ A}/\mu\text{s}$	$f = 60 \text{ Hz}$	$T_j = 125^\circ\text{C}$	50	$\text{A}/\mu\text{s}$
$I_{GM}$	Peak gate current	$t_p = 20 \mu\text{s}$		1.2	A
$P_{G(AV)}$	Average gate power dissipation			0.2	W
$V_{RGM}$	Maximum peak reverse gate voltage			5	V
$T_{stg}$	Storage junction temperature range			-40 to +150	$^\circ\text{C}$
$T_j$	Maximum operating junction temperature			-40 to +125	$^\circ\text{C}$

**Table 3: Device timings**

Symbol	Parameter	Test conditions	Value	Unit
$t_{GT}$	Gate controlled turn on time	$I_{TM} = 10 \text{ A}$ , $T_j = 25^\circ\text{C}$ , $V_D = V_{DRM(max.)}$ , $I_{GT} = 10 \text{ mA}$ , $di_G/dt = 0.2 \text{ A}/\mu\text{s}$ , $R_G = 1 \text{ k}\Omega$	0.5 (typ.)	$\mu\text{s}$
$t_Q$	Circuit controlled turn off time	$I_{TM} = 8 \text{ A}$ , $T_j = 125^\circ\text{C}$ , $V_D = 67\% V_{DRM(max.)}$ , $V_R = 10 \text{ V}$ , $di_T/dt = 10 \text{ A}/\mu\text{s}$ , $dV_D/dt = 2 \text{ V}/\mu\text{s}$ , $R_G = 1 \text{ k}\Omega$	60 (typ.)	

Table 4: Electrical characteristics ( $T_j = 25\text{ °C}$  unless otherwise specified)

Symbol	Test Conditions		Value	Unit		
$I_{GT}$	$V_D = 12\text{ V}, R_L = 33\ \Omega$		Max.	200	$\mu\text{A}$	
$V_{GT}$			Max.	0.8	V	
$V_{GD}$	$V_D = V_{DRM}, R_L = 33\ \text{k}\Omega, R_{GK} = 220\ \Omega$	$T_j = 125\text{ °C}$	Min.	0.1	V	
$I_H$	$I_T = 50\ \text{mA}, R_{GK} = 1\ \text{k}\Omega$		Max.	5	mA	
$I_L$	$I_G = 2\ \text{mA}, R_{GK} = 1\ \text{k}\Omega$		Max.	6	mA	
$dV/dt$	$V_D = 67\% V_{DRM}, R_{GK} = 220\ \Omega$	$T_j = 125\text{ °C}$	Min.	5	$\text{V}/\mu\text{s}$	
$V_{TM}$	$I_{TM} = 8\ \text{A}, t_p = 380\ \mu\text{s}$		Max.	1.6	V	
$V_{T0}$	Threshold voltage		Max.	0.85	V	
$R_D$	Dynamic resistance		Max.	90	$\text{m}\Omega$	
$I_{DRM}$	$V_D = V_R = V_{DRM} = V_{RRM}, R_{GK} = 220\ \Omega$		$T_j = 25\text{ °C}$	Max.	5	$\mu\text{A}$
$I_{RRM}$			$T_j = 125\text{ °C}$	Max.	1	mA

Table 5: Thermal parameters

Symbol	Parameter		Value	Unit	
$R_{th(j-c)}$	Junction to case (DC)		3.0	$^{\circ}\text{C}/\text{W}$	
$R_{th(j-a)}$	Junction to ambient (DC)	$S^{(1)} = 0.5\ \text{cm}^2$	DPAK		70
			IPAK		100
			TO-220AB		60

**Notes:**

(1)Copper surface under tab

# 1.1 Characteristics (curves)

**Figure 1: Maximum average power dissipation versus average on-state current**

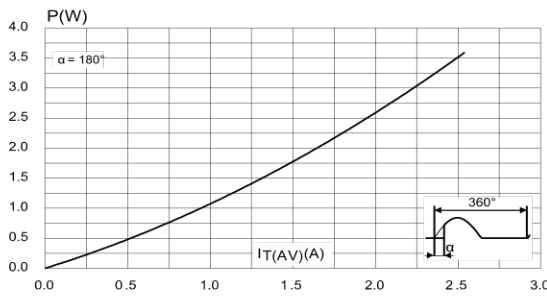

**Figure 2: Average and DC on-state current versus case temperature**

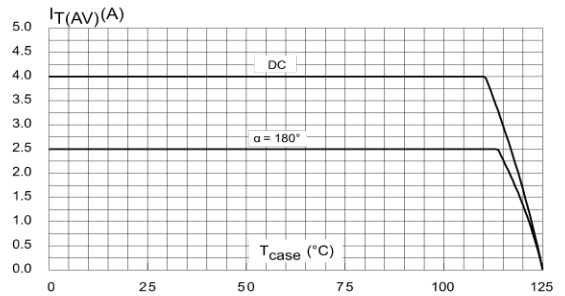

**Figure 3: Average and D.C. on state current versus ambient temperature (DPAK)**

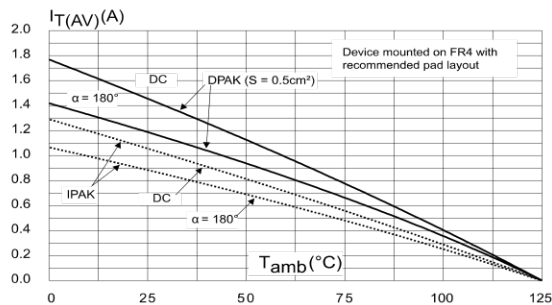

**Figure 4: Relative variation of thermal impedance junction to ambient versus pulse duration (DPAK)**

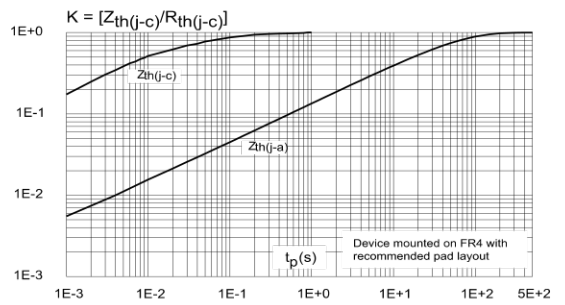

**Figure 5: Relative variation of gate trigger current and holding current versus junction temperature**

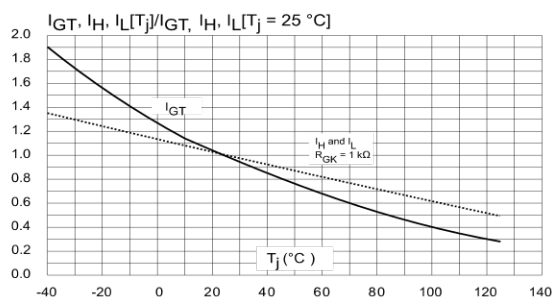

**Figure 6: Relative variation of holding current versus gate-cathode resistance (typical values)**

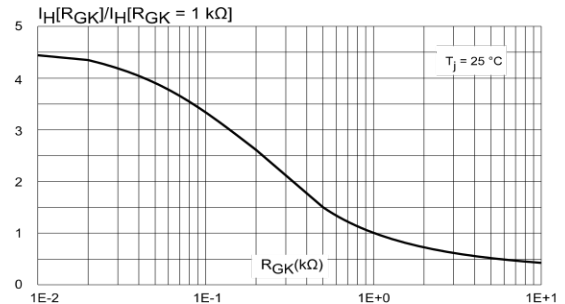

**Figure 7: Relative variation of dV/dt immunity versus gate-cathode resistance (typical values)**

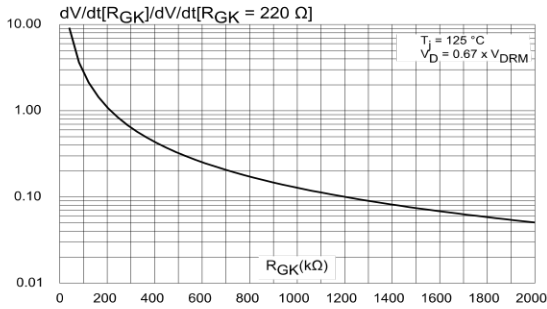

**Figure 8: Relative variation of dV/dt immunity versus gate-cathode capacitance (typical values)**

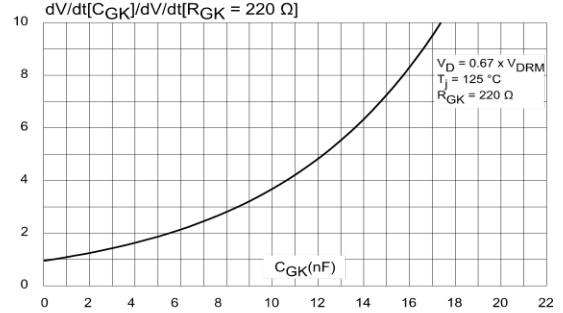

**Figure 9: Surge peak on-state current versus number of cycles**

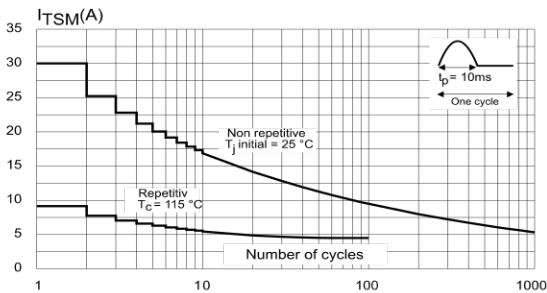

**Figure 10: Non-repetitive surge peak on-state current**

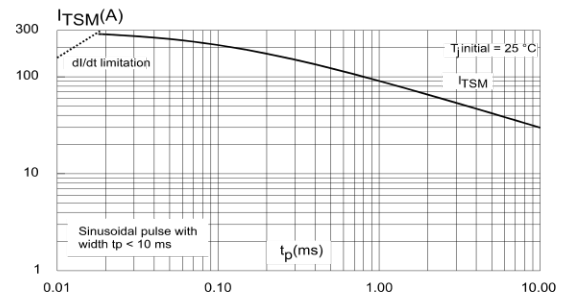

**Figure 11: On-state characteristics (maximum values)**

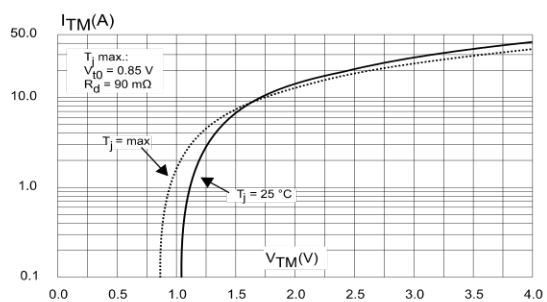

**Figure 12: Thermal resistance junction to ambient versus copper surface under tab**

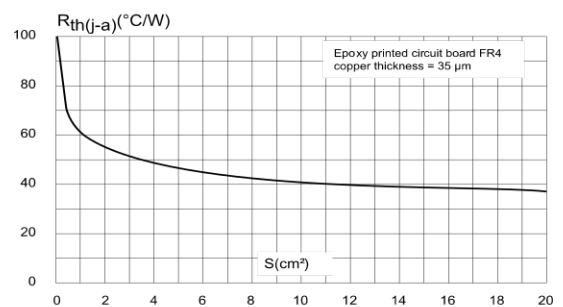

## 2 Package information

In order to meet environmental requirements, ST offers these devices in different grades of ECOPACK® packages, depending on their level of environmental compliance. ECOPACK® specifications, grade definitions and product status are available at: [www.st.com](http://www.st.com). ECOPACK® is an ST trademark.

- Epoxy meets UL 94, V0
- Lead-free packages
- Recommended torque value: 0.4 to 0.6 N·m

### 2.1 DPAK package information

Figure 13: DPAK package outline

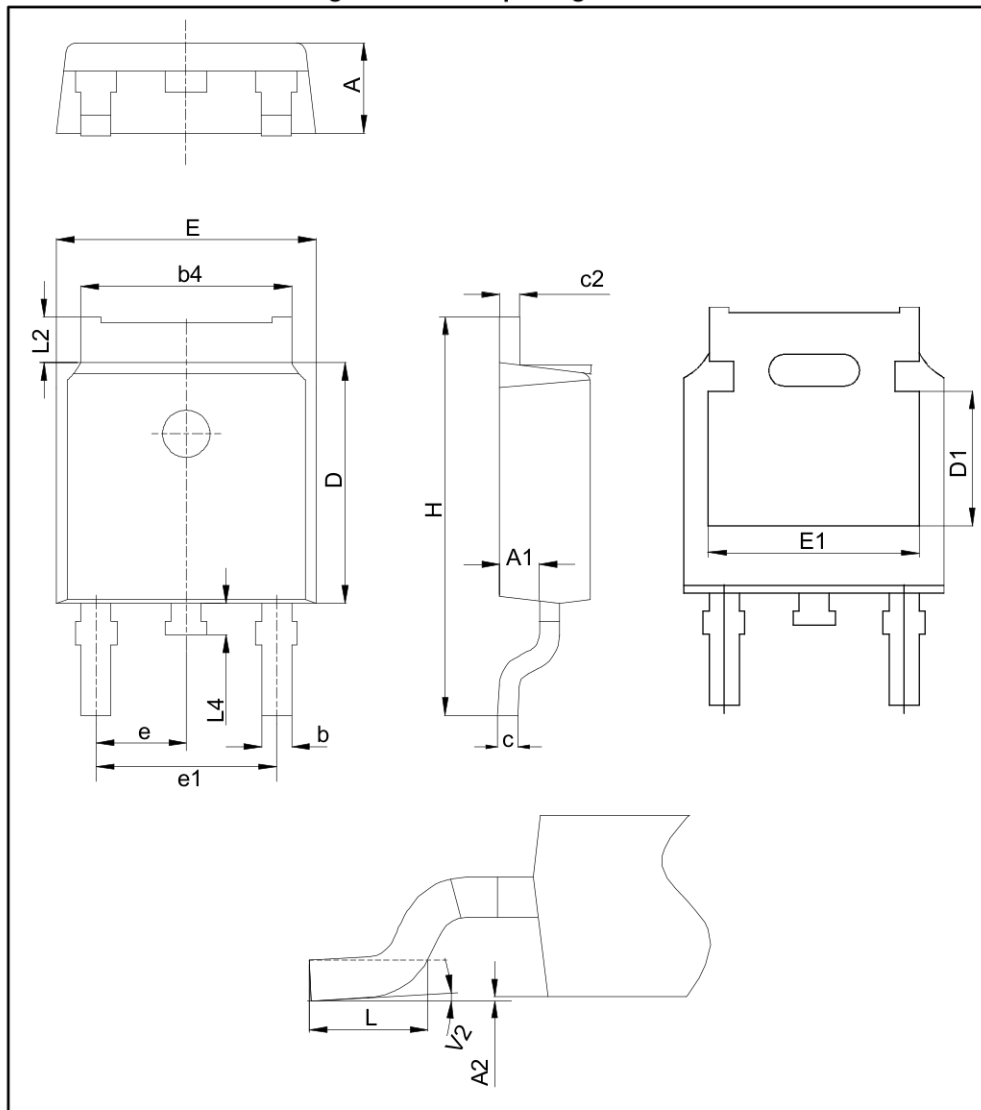

This package drawing may slightly differ from the physical package. However, all the specified dimensions are guaranteed.

Table 6: DPAK package mechanical data

Ref.	Dimensions					
	Millimeters			Inches <sup>(1)</sup>		
	Min.	Typ.	Max.	Min.	Typ.	Max.
A	2.18		2.40	0.0858		0.0945
A1	0.90		1.10	0.0354		0.0433
A2	0.03		0.23	0.0012		0.0091
b	0.64		0.90	0.0252		0.354
b4	4.95		5.46	0.1949		0.2150
c	0.46		0.61	0.0181		0.0240
c2	0.46		0.60	0.0181		0.0236
D	5.97		6.22	0.2350		0.2449
D1	5.10			0.2007		
E	6.35		6.73	0.2500		0.2650
E1	4.32			0.1701		
e		2.29			0.0900	
e1		4.57			0.1800	
H	9.35		10.40	0.3681		0.4094
L	1.00		1.78	0.0394		0.0701
L2			1.27			0.0500
L4	0.60		1.02	0.0236		0.0402
V2	0°		+8°	0°		+8°

**Notes:**

(1)Dimensions in inches are given for reference only

Figure 14: DPAK recommended footprint (dimensions are in mm)

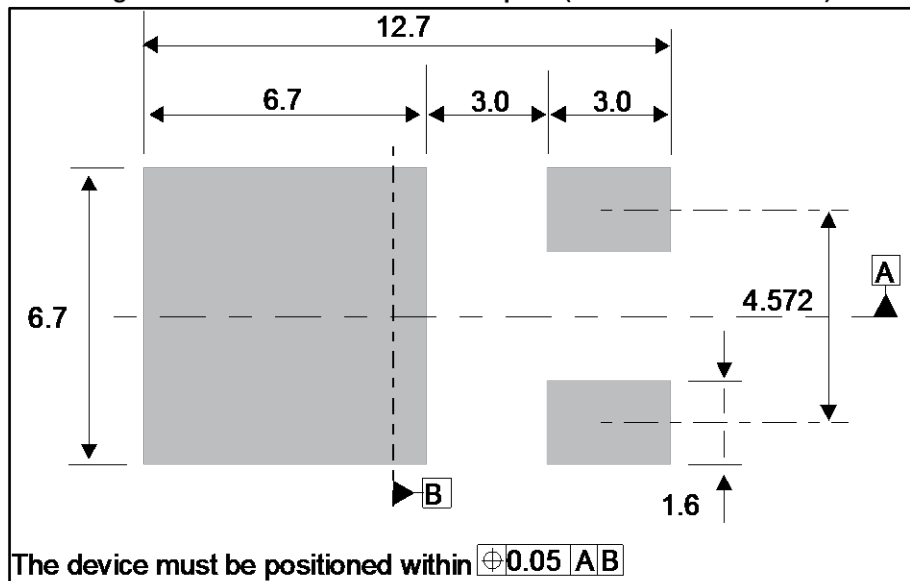

## 2.2 IPAK package information

Figure 15: IPAK package outline

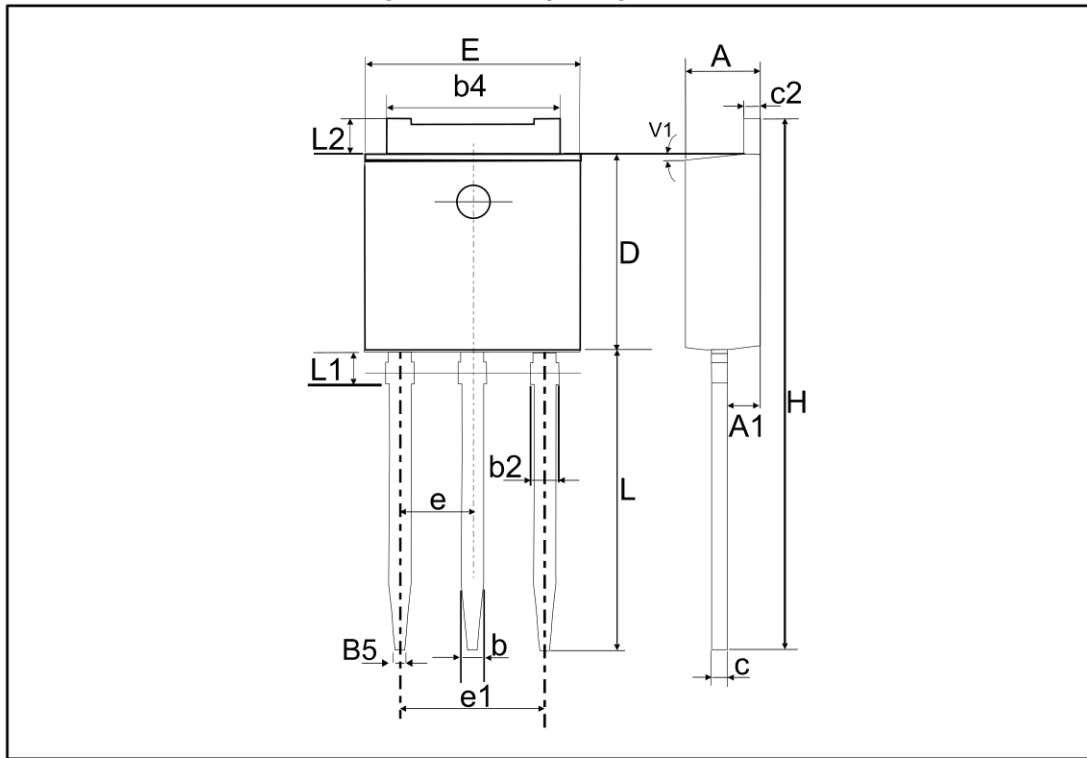

This package drawing may slightly differ from the physical package. However, all the specified dimensions are guaranteed.



Table 7: IPAK package mechanical data

Ref.	Dimensions					
	Millimeters			Inches <sup>(1)</sup>		
	Min.	Typ.	Max.	Min.	Typ.	Max.
A	2.20		2.40	0.0866		0.0945
A1	0.90		1.10	0.0354		0.0433
b	0.64		0.90	0.0252		0.0354
b2			0.95			0.0374
b4	5.20		5.43	0.2047		0.2138
B5		0.30			0.0118	
c	0.45		0.60	0.0177		0.0236
c2	0.46		0.60	0.0181		0.0236
D	6.00		6.20	0.2362		0.2441
E	6.40		6.65	0.2520		0.2618
e		2.28			0.0898	
e1	4.40		4.60	0.1732		0.1811
H		16.10			0.6339	
L	9.00		9.60	0.3545		0.3780
L1	0.80		1.20	0.0315		0.0472
L2		0.80	1.25		0.0315	0.0492
V1		10°			10°	

**Notes:**

<sup>(1)</sup>Inch dimensions are for reference only.

### 2.3 TO-220AB package information

Figure 16: TO-220AB package outline

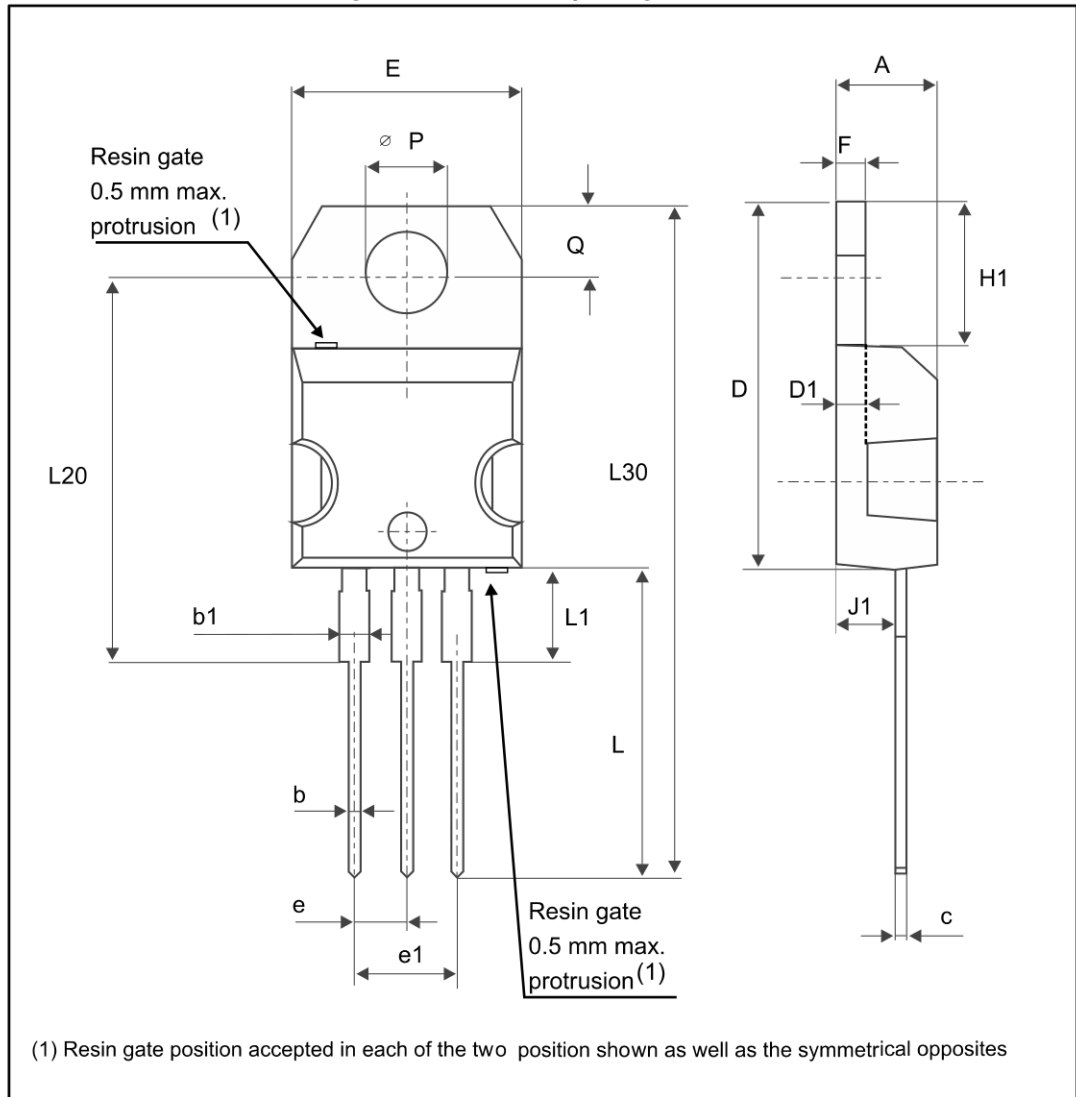

Table 8: TO-220AB package mechanical data

Ref.	Dimensions			
	Millimeters		Inches <sup>(1)</sup>	
	Min.	Max.	Min.	Max.
A	4.40	4.60	0.1732	0.1811
b	0.61	0.88	0.0240	0.0346
b1	1.14	1.55	0.0449	0.0610
c	0.48	0.70	0.0189	0.0276
D	15.25	15.75	0.6004	0.6201
D1	1.27 typ.		0.0500 typ.	
E	10.00	10.40	0.3937	0.4094
e	2.40	2.70	0.0945	0.1063
e1	4.95	5.15	0.1949	0.2028
F	1.23	1.32	0.0484	0.0520
H1	6.20	6.60	0.2441	0.2598
J1	2.40	2.72	0.0945	0.1071
L	13.00	14.00	0.5118	0.5512
L1	3.50	3.93	0.1378	0.1547
L20	16.40 typ.		0.6457 typ.	
L30	28.90 typ.		1.1378 typ.	
ØP	3.75	3.85	0.1476	0.1516
Q	2.65	2.95	0.1043	0.1161

**Notes:**

<sup>(1)</sup>Inch dimensions are for reference only.

### 3 Ordering information

Figure 17: Ordering information scheme

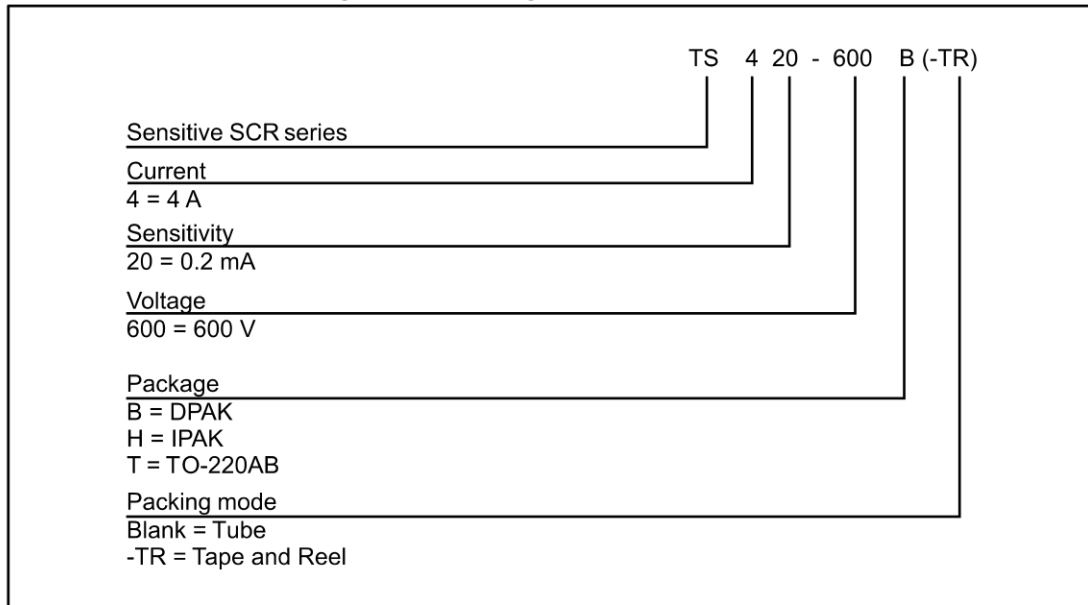

Table 9: Ordering information

Order code	Marking	Package	Weight	Base qty.	Delivery mode
TS420-600B	TS420600	DPAK	0.3 g	75	Tube
TS420-600B-TR	TS420600			2500	Tape and reel
TS420-600H	TS420600	IPAK	0.4 g	75	Tube
TS420-600T	TS420600T	TO-220AB	2.3 g	50	Tube

## 4 Revision history

Table 10: Document revision history

Date	Revision	Changes
Sep-2000	3	Previous release.
26-Jan-2010	4	Updated package illustration for TO-220AB on front page and Table 8. Added Table 5.
28-May-2014	5	Updated DPAK package information and reformatted to current standard.
10-May-2016	6	Updated cover page. Updated <i>Table 4: "Electrical characteristics (T<sub>j</sub> = 25 °C unless otherwise specified)"</i> , <i>Figure 10: "Non-repetitive surge peak on-state current "</i> and <i>Table 9: "Ordering information"</i> . Complete update of Package information section.
10-Oct-2017	7	Updated DPAK and D <sup>2</sup> PAK package information.

**IMPORTANT NOTICE – PLEASE READ CAREFULLY**

STMicroelectronics NV and its subsidiaries ("ST") reserve the right to make changes, corrections, enhancements, modifications, and improvements to ST products and/or to this document at any time without notice. Purchasers should obtain the latest relevant information on ST products before placing orders. ST products are sold pursuant to ST's terms and conditions of sale in place at the time of order acknowledgement.

Purchasers are solely responsible for the choice, selection, and use of ST products and ST assumes no liability for application assistance or the design of Purchasers' products.

No license, express or implied, to any intellectual property right is granted by ST herein.

Resale of ST products with provisions different from the information set forth herein shall void any warranty granted by ST for such product.

ST and the ST logo are trademarks of ST. All other product or service names are the property of their respective owners.

Information in this document supersedes and replaces information previously supplied in any prior versions of this document.

© 2017 STMicroelectronics – All rights reserved