

TL783 High-voltage Adjustable Regulator

1 Features

- Output Adjustable From 1.25 V to 125 V when Used with an External Resistor Divider
- 700-mA Output Current
- Full Short-Circuit, Safe-Operating-Area, and Thermal-Shutdown Protection
- 0.001%/V Typical Input Voltage Regulation
- 0.15% Typical Output Voltage Regulation
- 76-dB Typical Ripple Rejection

2 Applications

- Electronic Point of Sale
- Medical, Health, and Fitness Applications
- Printers
- Applications and White Goods

3 Description

The TL783 device is an adjustable three-terminal high-voltage regulator with an output range of 1.25 V to 125 V and a DMOS output transistor capable of sourcing more than 700 mA. It is designed for use in high-voltage applications where standard bipolar regulators cannot be used. Excellent performance specifications, superior to those of most bipolar regulators, are achieved through circuit design and advanced layout techniques.

Device Information⁽¹⁾

PART NUMBER	PACKAGE (PIN)	BODY SIZE (NOM)
TL783	TO-220 (3)	10.17 mm × 9.02 mm
		10.16 mm × 8.70 mm
	PFM (3)	9.40 mm × 8.00 mm
	TO-263 (3)	10.18 mm × 8.41 mm

(1) For all available packages, see the orderable addendum at the end of the data sheet.

4 Simplified Schematic

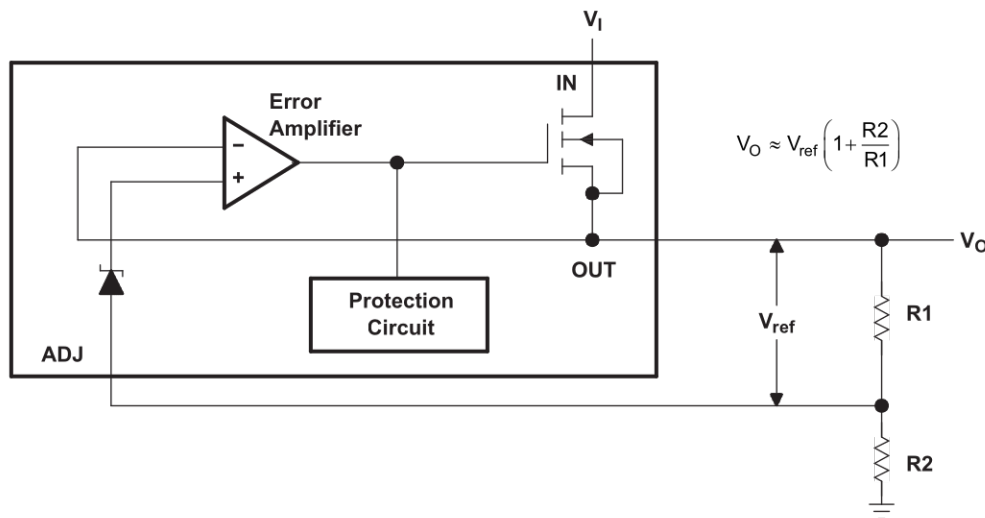

Table of Contents

1 Features	1	8.2 Functional Block Diagram	8
2 Applications	1	8.3 Feature Description	8
3 Description	1	8.4 Device Functional Modes	8
4 Simplified Schematic	1	9 Application and Implementation	9
5 Revision History	2	9.1 Application Information	9
6 Pin Configuration and Functions	3	9.2 Typical Application	12
7 Specifications	4	10 Power Supply Recommendations	16
7.1 Absolute Maximum Ratings	4	11 Layout	16
7.2 ESD Ratings	4	11.1 Layout Guidelines	16
7.3 Recommended Operating Conditions	4	11.2 Layout Example	16
7.4 Thermal Information	4	12 Device and Documentation Support	16
7.5 Electrical Characteristics	5	12.1 Trademarks	16
7.6 Typical Characteristics	6	12.2 Electrostatic Discharge Caution	16
8 Detailed Description	8	12.3 Glossary	16
8.1 Overview	8	13 Mechanical, Packaging, and Orderable Information	16

5 Revision History

Changes from Revision M (April 2008) to Revision N

Page

- Added *Applications*, *Device Information* table, *Pin Functions* table, *ESD Ratings* table, *Thermal Information* table, *Typical Characteristics*, *Feature Description* section, *Device Functional Modes*, *Application and Implementation* section, *Power Supply Recommendations* section, *Layout* section, *Device and Documentation Support* section, and *Mechanical, Packaging, and Orderable Information* section. **1**
- Deleted *Ordering Information* table. **1**

6 Pin Configuration and Functions

**KC (TO-220) PACKAGE
(TOP VIEW)**

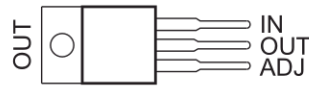

**KTE (PowerFLEX™) PACKAGE
(TOP VIEW)**

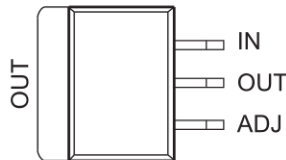

**KTT (TO-263) PACKAGE
(TOP VIEW)**

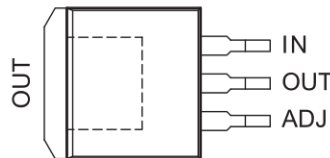

Pin Functions

NAME	PIN			TYPE	DESCRIPTION
	KC TO-220	KTE PowerFLEX™	KTT TO-263		
ADJ	1	1	1	I/O	Voltage adjustment pin. Connect a resistor divider to determine the output voltage.
IN	3	3	3	I	Supply Input
OUT	2	2	2	O	Voltage Output

7 Specifications

7.1 Absolute Maximum Ratings

over operating temperature range (unless otherwise noted)⁽¹⁾

		MIN	MAX	UNIT
$V_I - V_O$	Input-to-output differential voltage		125	V
T_J	Operating virtual junction temperature		150	°C
T_{stg}	Storage temperature range	-65	150	°C

- (1) Stresses beyond those listed under *Absolute Maximum Ratings* may cause permanent damage to the device. These are stress ratings only, and functional operation of the device at these or any other conditions beyond those indicated under *Recommended Operating Conditions* is not implied. Exposure to absolute-maximum-rated conditions for extended periods may affect device reliability.

7.2 ESD Ratings

		VALUE	UNIT
$V_{(ESD)}$	Electrostatic discharge		
	Human body model (HBM), per ANSI/ESDA/JEDEC JS-001, all pins ⁽¹⁾	2500	V
	Charged device model (CDM), per JEDEC specification JESD22-C101, all pins ⁽²⁾	1000	

- (1) JEDEC document JEP155 states that 500-V HBM allows safe manufacturing with a standard ESD control process.
 (2) JEDEC document JEP157 states that 250-V CDM allows safe manufacturing with a standard ESD control process.

7.3 Recommended Operating Conditions

		MIN	MAX	UNIT
$V_I - V_O$	Input-to-output differential voltage		125	V
I_O	Output current	15	700	mA
T_J	Operating virtual junction temperature	0	125	°C

7.4 Thermal Information

	THERMAL METRIC ⁽¹⁾	TL783			UNIT
		KTE	KTT	KC	
		3 PINS			
$R_{\theta JA}$	Junction-to-ambient thermal resistance	23	25.3	19	°C/W
$R_{\theta JC(top)}$	Junction-to-case (top) thermal resistance	N/A	18	17	
$R_{\theta JP}$	Junction-to-exposed-pad thermal resistance	2.7	1.94	3	

- (1) For more information about traditional and new thermal metrics, see the *IC Package Thermal Metrics* application report, [SPRA953](http://www.ti.com/lit/zip/Spra953).

7.5 Electrical Characteristics

 $V_I - V_O = 25\text{ V}$, $I_O = 0.5\text{ A}$, $T_J = 0^\circ\text{C}$ to 125°C (unless otherwise noted)

PARAMETER	TEST CONDITIONS ⁽¹⁾	MIN	TYP	MAX	UNIT
Input voltage regulation ⁽²⁾	$V_I - V_O = 20\text{ V}$ to 125 V , $P \leq$ rated dissipation	$T_J = 25^\circ\text{C}$	0.001	0.01	%V
		$T_J = 0^\circ\text{C}$ to 125°C	0.004	0.02	
Ripple rejection	$\Delta V_{I(PP)} = 10\text{ V}$, $V_O = 10\text{ V}$, $f = 120\text{ Hz}$	66	76		dB
Output voltage regulation	$I_O = 15\text{ mA}$ to 700 mA , $T_J = 25^\circ\text{C}$	$V_O \leq 5\text{ V}$	7.5	25	mV
		$V_O \geq 5\text{ V}$	0.15%	0.5%	—
	$I_O = 15\text{ mA}$ to 700 mA , $P \leq$ rated dissipation	$V_O \leq 5\text{ V}$	20	70	mV
		$V_O \geq 5\text{ V}$	0.3%	1.5%	—
Output voltage change with temperature			0.4%		—
Output voltage long-term drift	1000 hours at $T_J = 125^\circ\text{C}$, $V_I - V_O = 125\text{ V}$		0.2%		—
Output noise voltage	$f = 10\text{ Hz}$ to 10 kHz , $T_J = 25^\circ\text{C}$		0.003%		—
Minimum output current to maintain regulation	$V_I - V_O = 125\text{ V}$			15	mA
Peak output current	$V_I - V_O = 25\text{ V}$, $t = 1\text{ ms}$		1100		mA
	$V_I - V_O = 15\text{ V}$, $t = 30\text{ ms}$		715		
	$V_I - V_O = 25\text{ V}$, $t = 30\text{ ms}$	700	900		
	$V_I - V_O = 125\text{ V}$, $t = 30\text{ ms}$	100	250		
ADJ input current			83	110	μA
Change in ADJ input current	$V_I - V_O = 15\text{ V}$ to 125 V , $I_O = 15\text{ mA}$ to 700 mA , $P \leq$ rated dissipation		0.5	5	μA
Reference voltage (OUT to ADJ) ⁽³⁾	$V_I - V_O = 10\text{ V}$ to 125 V , $I_O = 15\text{ mA}$ to 700 mA , $P \leq$ rated dissipation	1.2	1.27	1.3	V

- (1) Pulse-testing techniques maintain the junction temperature as close to the ambient temperature as possible. Thermal effects must be taken into account separately.
- (2) Input voltage regulation is expressed here as the percentage change in output voltage per 1-V change at the input
- (3) Due to the dropout voltage and output current-limiting characteristics of this device, output current is limited to less than 700 mA at input-to-output voltage differentials of less than 25 V.

7.6 Typical Characteristics

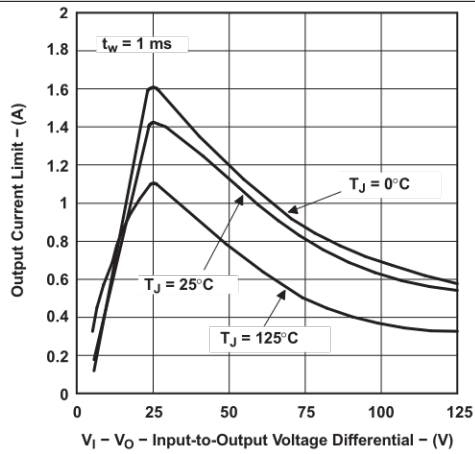

Figure 1. Output Current Limit vs Input-to-Output Voltage Differential

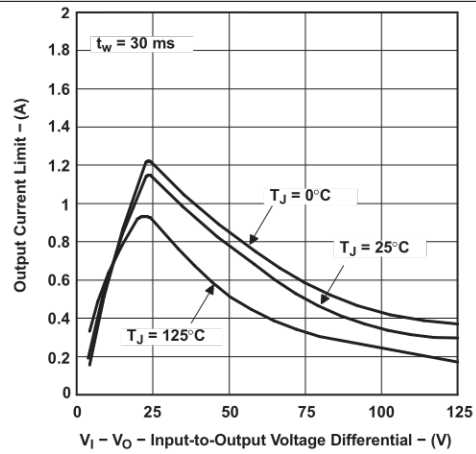

Figure 2. Output Current Limit vs Input-to-Output Voltage Differential

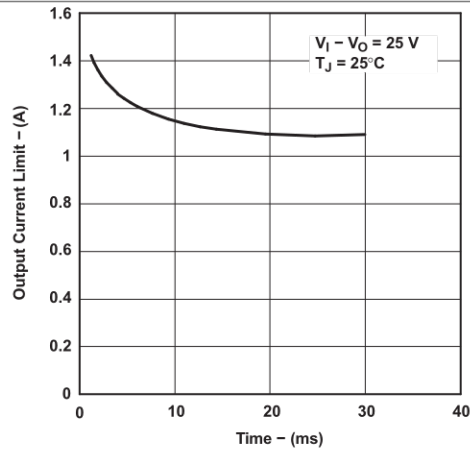

Figure 3. Output Current Limit vs Time

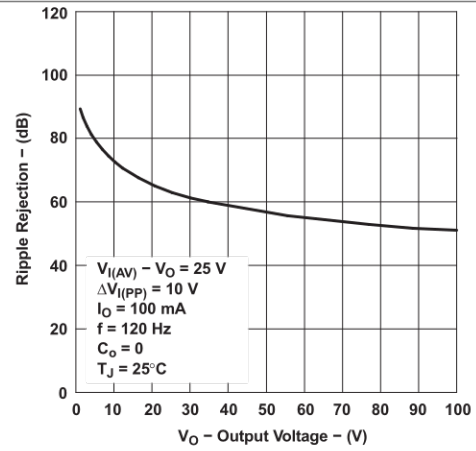

Figure 4. Ripple Rejection vs Output Voltage

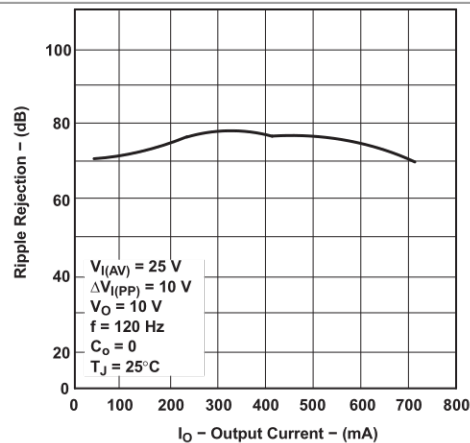

Figure 5. Ripple Rejection vs Output Current

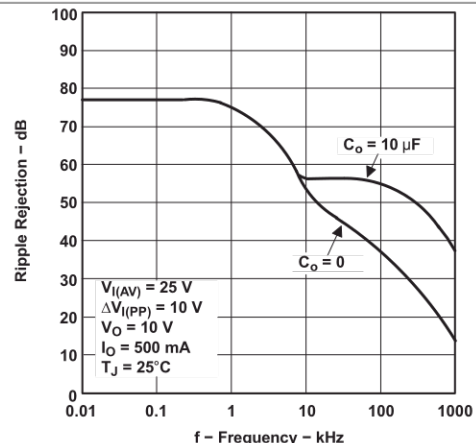

Figure 6. Ripple Rejection vs Frequency

Typical Characteristics (continued)

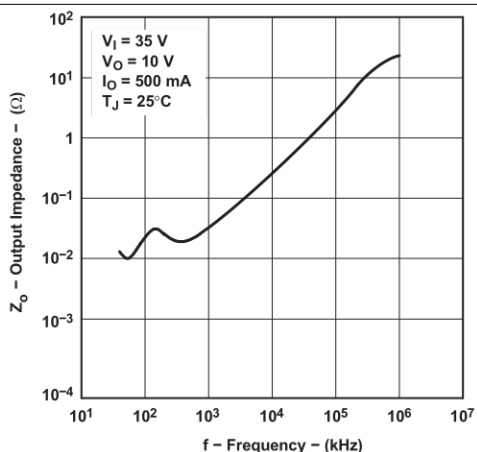

Figure 7. Output Impedance vs Frequency

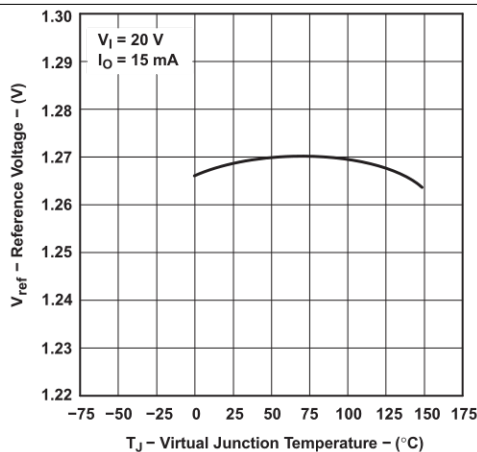

Figure 8. Reference Voltage vs Virtual Junction Temperature

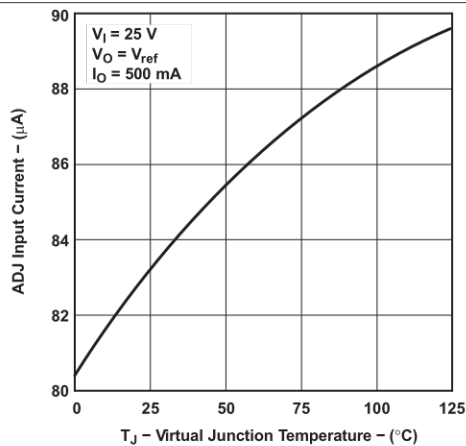

Figure 9. Input Current at ADJ vs Virtual Junction Temperature

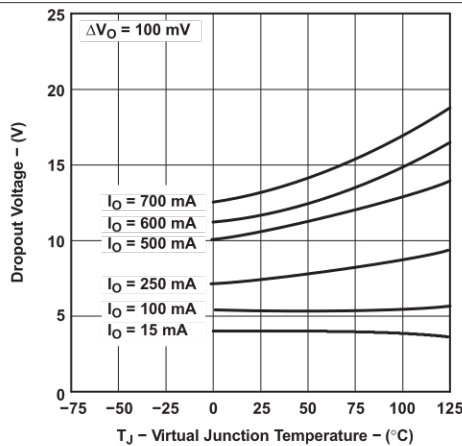

Figure 10. Dropout Voltage vs Virtual Junction Temperature

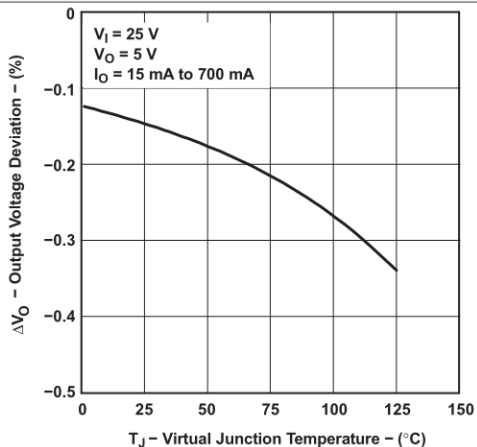
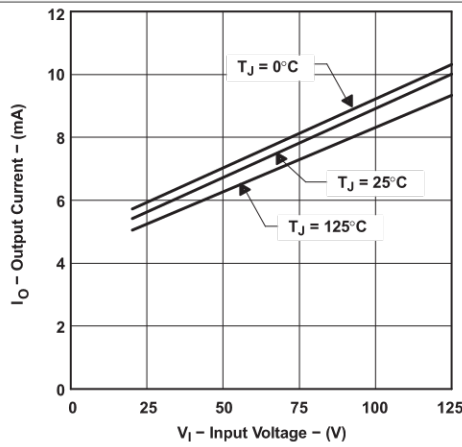

Figure 11. Output Voltage Deviation vs Virtual Junction Temperature



(1) This is the minimum current required to maintain voltage regulation.

Figure 12. Output Current vs Input Voltage

8 Detailed Description

8.1 Overview

The TL783 device is an adjustable three-terminal high-voltage regulator with an output range of 1.25 V to 125 V and a DMOS output transistor capable of sourcing more than 700 mA. It is designed for use in high-voltage applications where standard bipolar regulators cannot be used. Excellent performance specifications, superior to those of most bipolar regulators, are achieved through circuit design and advanced layout techniques.

As a state-of-the-art regulator, the TL783 device combines standard bipolar circuitry with high-voltage double-diffused MOS transistors on one chip, to yield a device capable of withstanding voltages far higher than standard bipolar integrated circuits. Because of its lack of secondary-breakdown and thermal-runaway characteristics usually associated with bipolar outputs, the TL783 maintains full overload protection while operating at up to 125 V from input to output. Other features of the device include current limiting, safe-operating-area (SOA) protection, and thermal shutdown. Even if ADJ is disconnected inadvertently, the protection circuitry remains functional.

Only two external resistors are required to program the output voltage. An input bypass capacitor is necessary only when the regulator is situated far from the input filter. An output capacitor, although not required, improves transient response and protection from instantaneous output short circuits. Excellent ripple rejection can be achieved without a bypass capacitor at the adjustment terminal.

8.2 Functional Block Diagram

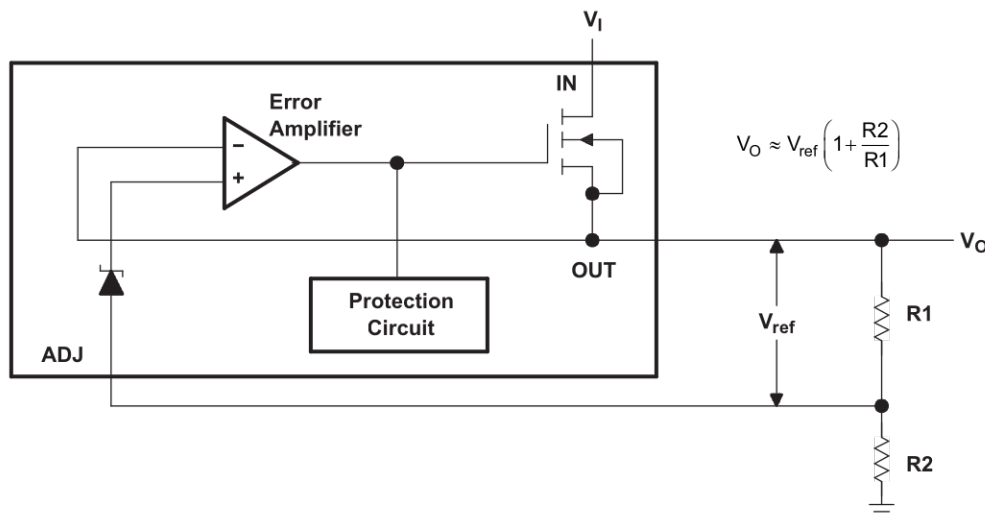

8.3 Feature Description

- Output Adjustable From 1.25 V to 125 V when Used with an External Resistor Divider
- 700-mA Output Current
- Full Short-Circuit, Safe-Operating-Area, and Thermal-Shutdown Protection
- 0.001%/V Typical Input Voltage Regulation
- 0.15% Typical Output Voltage Regulation
- 76-dB Typical Ripple Rejection

8.4 Device Functional Modes

8.4.1 Active Mode

The TL783 acts as a high-voltage adjustable regulator. The device works to keep the voltage at the OUT pin 1.25 V higher than the voltage at the ADJ pin. Therefore, a resistor divider can be used to set the output voltage.

9 Application and Implementation

NOTE

Information in the following applications sections is not part of the TI component specification, and TI does not warrant its accuracy or completeness. TI's customers are responsible for determining suitability of components for their purposes. Customers should validate and test their design implementation to confirm system functionality.

9.1 Application Information

9.1.1 General Configurations

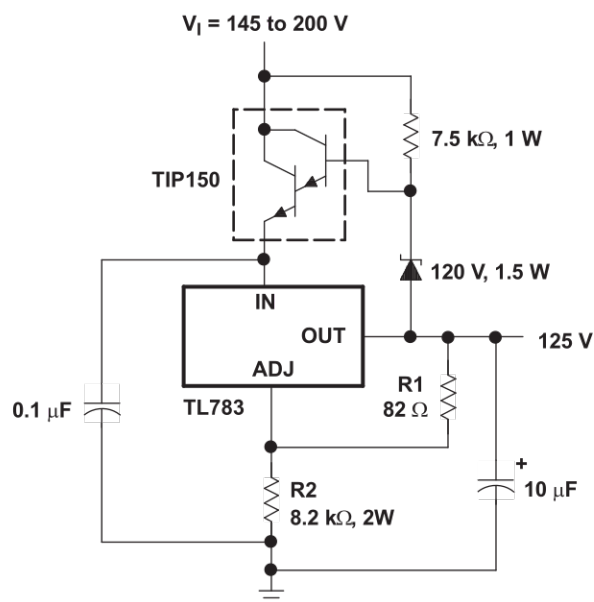

Figure 13. 125-V Short-Circuit-Protected Off-Line Regulator

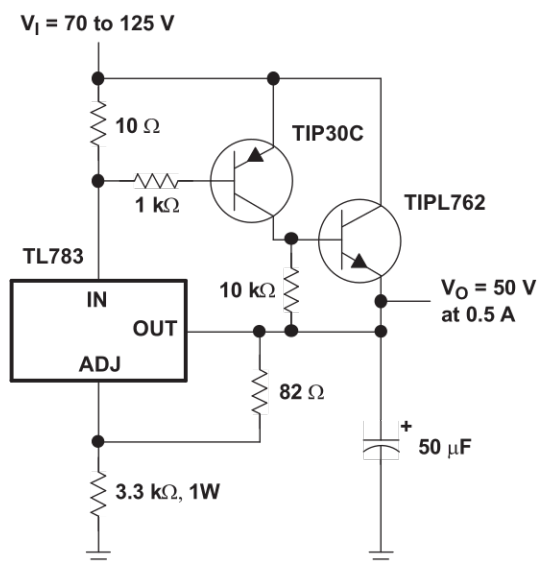

Figure 14. 50-V Regulator With Current Boost

Application Information (continued)

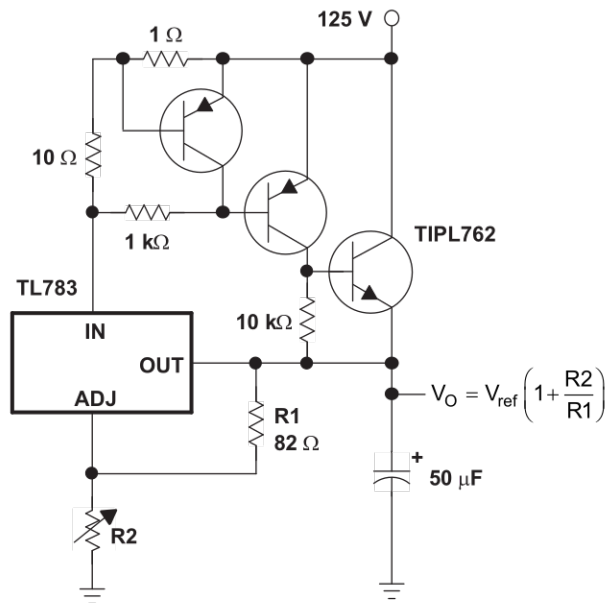

Figure 15. Adjustable Regulator With Current Boost and Current Limit

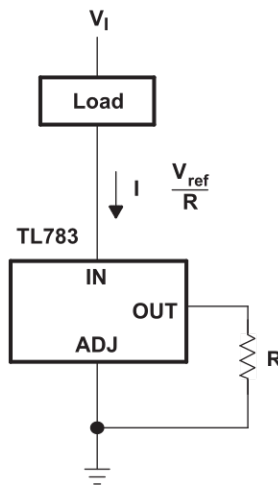

Figure 16. Current-Sinking Regulator

Application Information (continued)

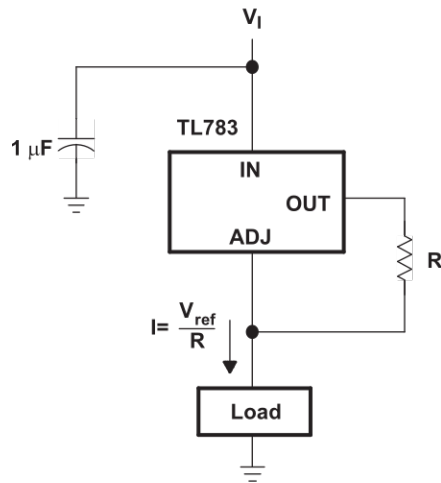

Figure 17. Current-Sourcing Regulator

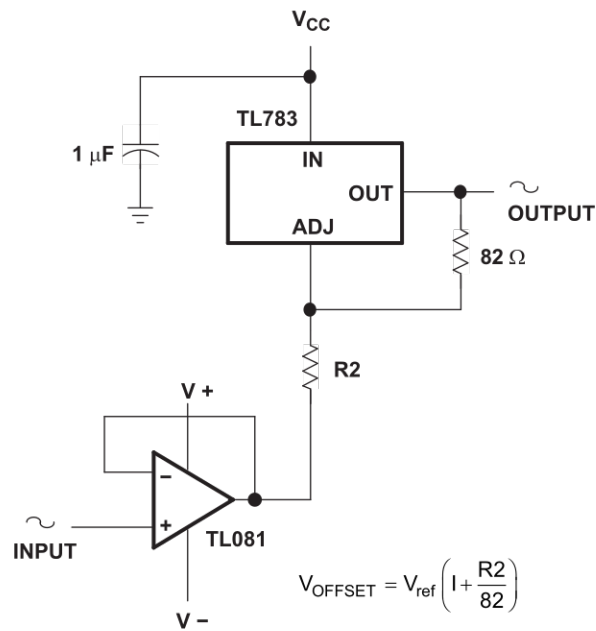
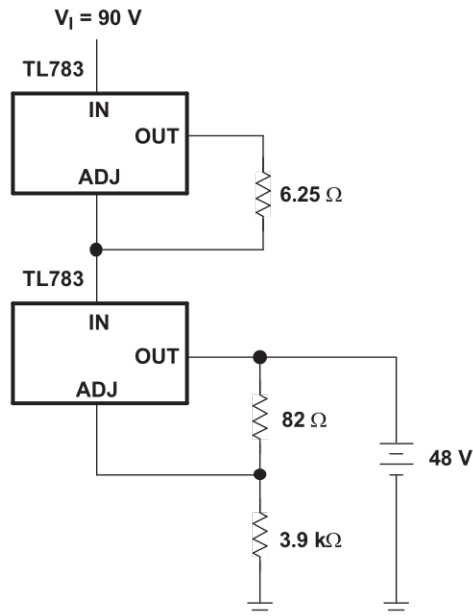
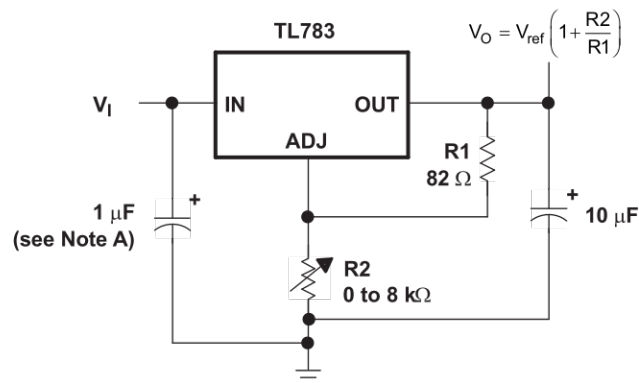

Figure 18. High-Voltage Unity-Gain Offset Amplifier

Application Information (continued)

Figure 19. 48-V 200-mA Float Charger
9.2 Typical Application

The TL783 is typically used as an adjustable regulator.



A. Needed if device is more than 4 inches from filter capacitor

Figure 20. 1.25-V to 115-V Adjustable Regulator
9.2.1 Design Requirements

- Input and output decoupling capacitors for noise filtering.
- Resistor divider consisting of R1 and R2 to set the output voltage.

Typical Application (continued)

9.2.2 Detailed Design Procedure

The internal reference (see [Simplified Schematic](#)) generates 1.25 V nominal (V_{ref}) between OUT and ADJ. This voltage is developed across R1 and causes a constant current to flow through R1 and the programming resistor R2, giving an output voltage of:

$$V_O = V_{ref} (1 + R2 / R1) + I_{I(ADJ)} (R2)$$

or

$$V_O \neq V_{ref} (1 + R2 / R1)$$

The TL783 was designed to minimize the input current at ADJ and maintain consistency over line and load variations, thereby minimizing the associated (R2) error term.

To maintain $I_{I(ADJ)}$ at a low level, all quiescent operating current is returned to the output terminal. This quiescent current must be sunk by the external load and is the minimum load current necessary to prevent the output from rising. The recommended R1 value of 82 Ω provides a minimum load current of 15 mA. Larger values can be used when the input-to-output differential voltage is less than 125 V (see the output-current curve in [Figure 12](#)) or when the load sinks some portion of the minimum current.

9.2.2.1 Bypass Capacitors

The TL783 regulator is stable without bypass capacitors; however, any regulator becomes unstable with certain values of output capacitance if an input capacitor is not used. Therefore, the use of input bypassing is recommended whenever the regulator is located more than four inches from the power-supply filter capacitor. A 1- μ F tantalum or aluminum electrolytic capacitor usually is sufficient.

Adjustment-terminal capacitors are not recommended for use on the TL783 because they can seriously degrade load transient response, as well as create a need for extra protection circuitry. Excellent ripple rejection presently is achieved without this added capacitor.

Due to the relatively low gain of the MOS output stage, output voltage dropout may occur under large-load transient conditions. The addition of an output bypass capacitor greatly enhances load transient response and prevents dropout. For most applications, it is recommended that an output bypass capacitor be used, with a minimum value of:

$$C_o (\mu\text{F}) = 15 / V_O$$

Larger values provide proportionally better transient-response characteristics.

Typical Application (continued)

9.2.2.2 Protection Circuitry

The TL783 regulator includes built-in protection circuits capable of guarding the device against most overload conditions encountered in normal operation. These protective features are current limiting, safe-operating-area protection, and thermal shutdown. These circuits protect the device under occasional fault conditions only. Continuous operation in the current limit or thermal shutdown mode is not recommended.

The internal protection circuits of the TL783 protect the device up to maximum-rated V_I as long as certain precautions are taken. If V_I is switched on instantaneously, transients exceeding maximum input ratings may occur, which can destroy the regulator. Usually, these are caused by lead inductance and bypass capacitors causing a ringing voltage on the input. In addition, when rise times in excess of 10 V/ns are applied to the input, a parasitic npn transistor in parallel with the DMOS output can be turned on, causing the device to fail. If the device is operated over 50 V and the input is switched on, rather than ramped on, a low-Q capacitor, such as tantalum or aluminum electrolytic, should be used, rather than ceramic, paper, or plastic bypass capacitors. A Q factor of 0.015, or greater, usually provides adequate damping to suppress ringing. Normally, no problems occur if the input voltage is allowed to ramp upward through the action of an ac line rectifier and filter network.

Similarly, when an instantaneous short circuit is applied to the output, both ringing and excessive fall times can result. A tantalum or aluminum electrolytic bypass capacitor is recommended to eliminate this problem. However, if a large output capacitor is used, and the input is shorted, addition of a protection diode may be necessary to prevent capacitor discharge through the regulator. The amount of discharge current delivered is dependent on output voltage, size of capacitor, and fall time of V_I . A protective diode (see [Figure 21](#)) is required only for capacitance values greater than:

$$C_o (\mu\text{F}) = 3 \times 10^4 / (V_o)^2$$

Care always should be taken to prevent insertion of regulators into a socket with power on. Power should be turned off before removing or inserting regulators.

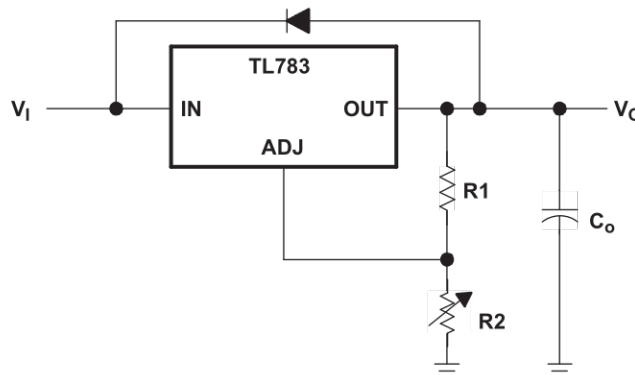

Figure 21. Regulator With Protective Diode

Typical Application (continued)

9.2.2.3 Load Regulation

The current-set resistor (R1) should be located close to the regulator output terminal, rather than near the load. This eliminates long line drops from being amplified, through the action of R1 and R2, to degrade load regulation. To provide remote ground sensing, R2 should be near the load ground.

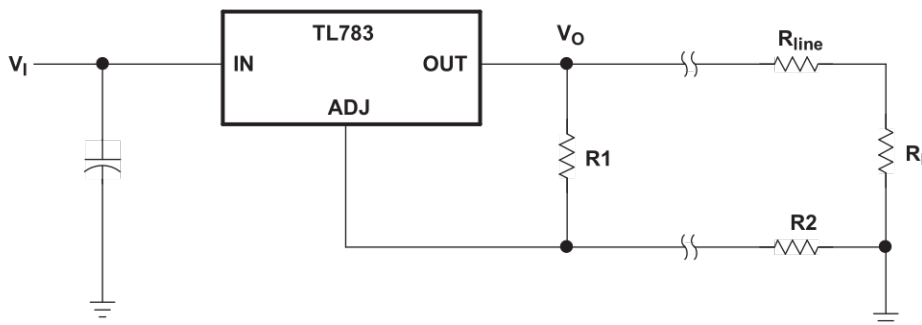
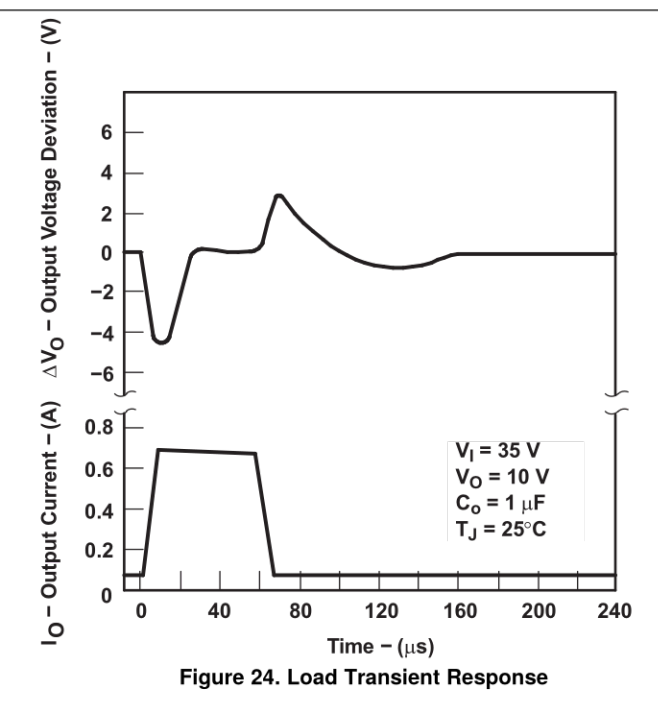
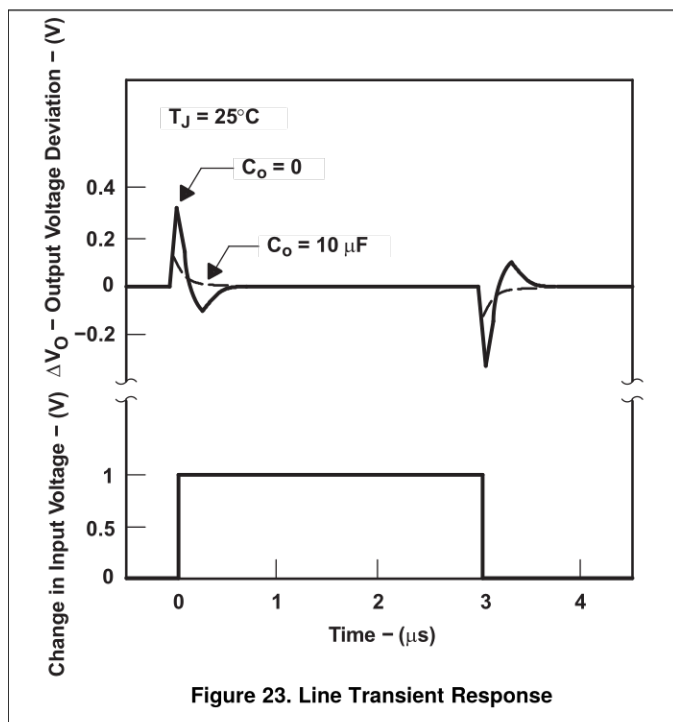

Figure 22. Regulator With Current-Set Resistor

9.2.3 Application Curves



10 Power Supply Recommendations

A decoupling capacitor is needed on the IN pin of the TL783 if the TL783 is more than 4 inches from its power supply's filter capacitor. The differential input and output voltage levels are detailed in [Recommended Operating Conditions](#).

11 Layout

11.1 Layout Guidelines

Input and output traces should be thick enough to handle desired currents, which can reach up to 700 mA on the output. ADJ pin traces can be smaller because the adjustment current is negligible.

11.2 Layout Example

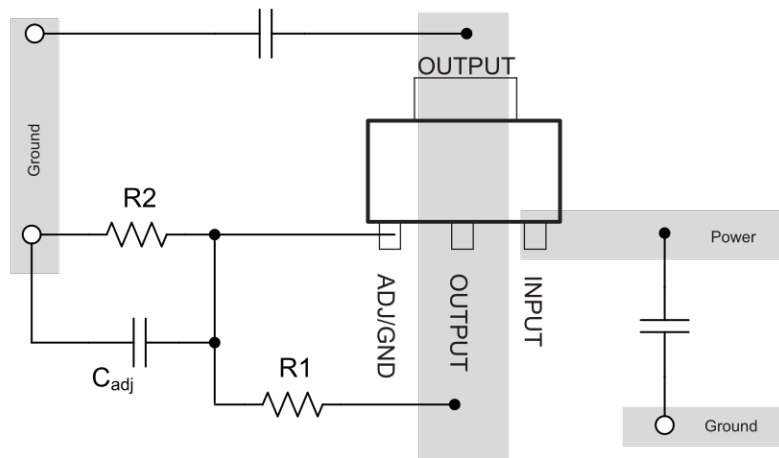

Figure 25. Layout Example

12 Device and Documentation Support

12.1 Trademarks

All trademarks are the property of their respective owners.

12.2 Electrostatic Discharge Caution



These devices have limited built-in ESD protection. The leads should be shorted together or the device placed in conductive foam during storage or handling to prevent electrostatic damage to the MOS gates.

12.3 Glossary

[SLYZ022](#) — *TI Glossary*.

This glossary lists and explains terms, acronyms, and definitions.

13 Mechanical, Packaging, and Orderable Information

The following pages include mechanical, packaging, and orderable information. This information is the most current data available for the designated devices. This data is subject to change without notice and revision of this document. For browser-based versions of this data sheet, refer to the left-hand navigation.

PACKAGING INFORMATION

Orderable Device	Status (1)	Package Type	Package Drawing	Pins	Package Qty	Eco Plan (2)	Lead finish/ Ball material (6)	MSL Peak Temp (3)	Op Temp (°C)	Device Marking (4/5)	Samples
TL783CKCSE3	ACTIVE	TO-220	KCS	3	50	RoHS & Green	SN	N / A for Pkg Type	0 to 125	TL783C	Samples
TL783CKTTR	ACTIVE	DDPAK/ TO-263	KTT	3	500	RoHS & Green	SN	Level-3-245C-168 HR	0 to 125	TL783C	Samples
TL783CKTTRG3	ACTIVE	DDPAK/ TO-263	KTT	3	500	RoHS & Green	SN	Level-3-245C-168 HR	0 to 125	TL783C	Samples

(1) The marketing status values are defined as follows:

ACTIVE: Product device recommended for new designs.

LIFEBUY: TI has announced that the device will be discontinued, and a lifetime-buy period is in effect.

NRND: Not recommended for new designs. Device is in production to support existing customers, but TI does not recommend using this part in a new design.

PREVIEW: Device has been announced but is not in production. Samples may or may not be available.

OBSOLETE: TI has discontinued the production of the device.

(2) **RoHS:** TI defines "RoHS" to mean semiconductor products that are compliant with the current EU RoHS requirements for all 10 RoHS substances, including the requirement that RoHS substance do not exceed 0.1% by weight in homogeneous materials. Where designed to be soldered at high temperatures, "RoHS" products are suitable for use in specified lead-free processes. TI may reference these types of products as "Pb-Free".

RoHS Exempt: TI defines "RoHS Exempt" to mean products that contain lead but are compliant with EU RoHS pursuant to a specific EU RoHS exemption.

Green: TI defines "Green" to mean the content of Chlorine (Cl) and Bromine (Br) based flame retardants meet JS709B low halogen requirements of <=1000ppm threshold. Antimony trioxide based flame retardants must also meet the <=1000ppm threshold requirement.

(3) MSL, Peak Temp. - The Moisture Sensitivity Level rating according to the JEDEC industry standard classifications, and peak solder temperature.

(4) There may be additional marking, which relates to the logo, the lot trace code information, or the environmental category on the device.

(5) Multiple Device Markings will be inside parentheses. Only one Device Marking contained in parentheses and separated by a "~" will appear on a device. If a line is indented then it is a continuation of the previous line and the two combined represent the entire Device Marking for that device.

(6) Lead finish/Ball material - Orderable Devices may have multiple material finish options. Finish options are separated by a vertical ruled line. Lead finish/Ball material values may wrap to two lines if the finish value exceeds the maximum column width.

Important Information and Disclaimer: The information provided on this page represents TI's knowledge and belief as of the date that it is provided. TI bases its knowledge and belief on information provided by third parties, and makes no representation or warranty as to the accuracy of such information. Efforts are underway to better integrate information from third parties. TI has taken and continues to take reasonable steps to provide representative and accurate information but may not have conducted destructive testing or chemical analysis on incoming materials and chemicals. TI and TI suppliers consider certain information to be proprietary, and thus CAS numbers and other limited information may not be available for release.

In no event shall TI's liability arising out of such information exceed the total purchase price of the TI part(s) at issue in this document sold by TI to Customer on an annual basis.

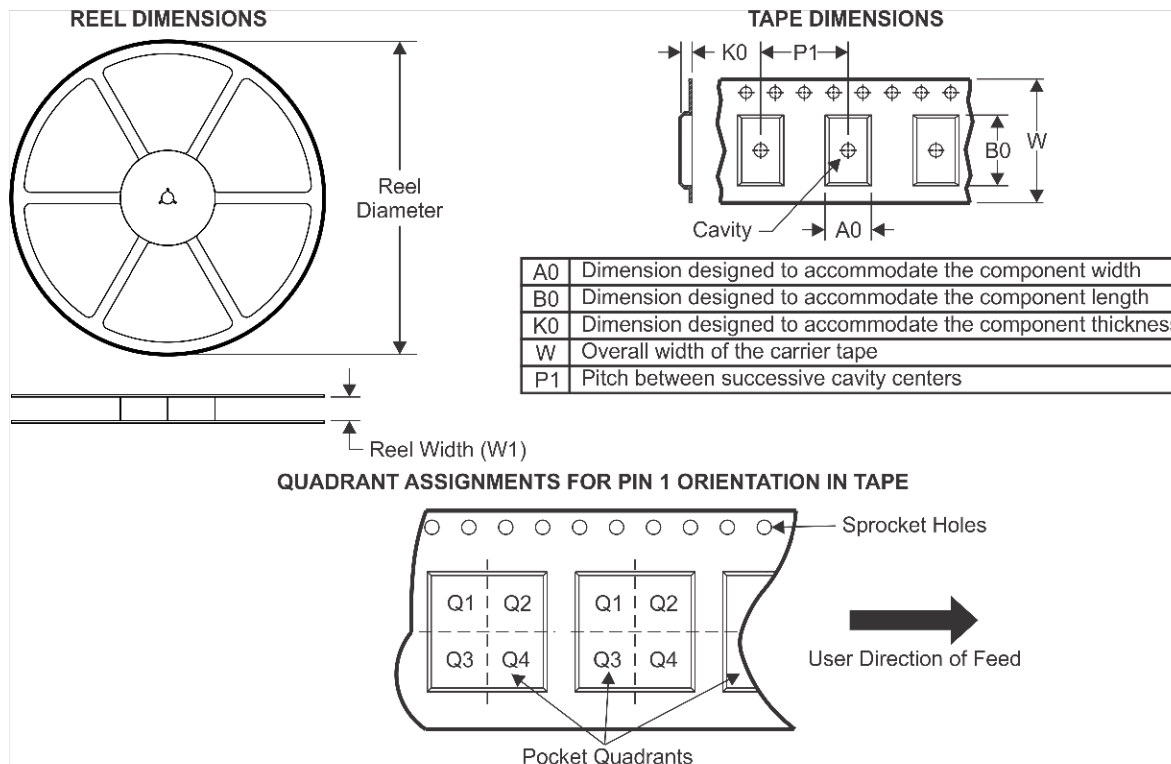
TAPE AND REEL INFORMATION

*All dimensions are nominal

Device	Package Type	Package Drawing	Pins	SPQ	Reel Diameter (mm)	Reel Width W1 (mm)	A0 (mm)	B0 (mm)	K0 (mm)	P1 (mm)	W (mm)	Pin1 Quadrant
TL783CKTTR	DDPAK/ TO-263	KTT	3	500	330.0	24.4	10.8	16.1	4.9	16.0	24.0	Q2
TL783CKTTR	DDPAK/ TO-263	KTT	3	500	330.0	24.4	10.8	16.3	5.11	16.0	24.0	Q2

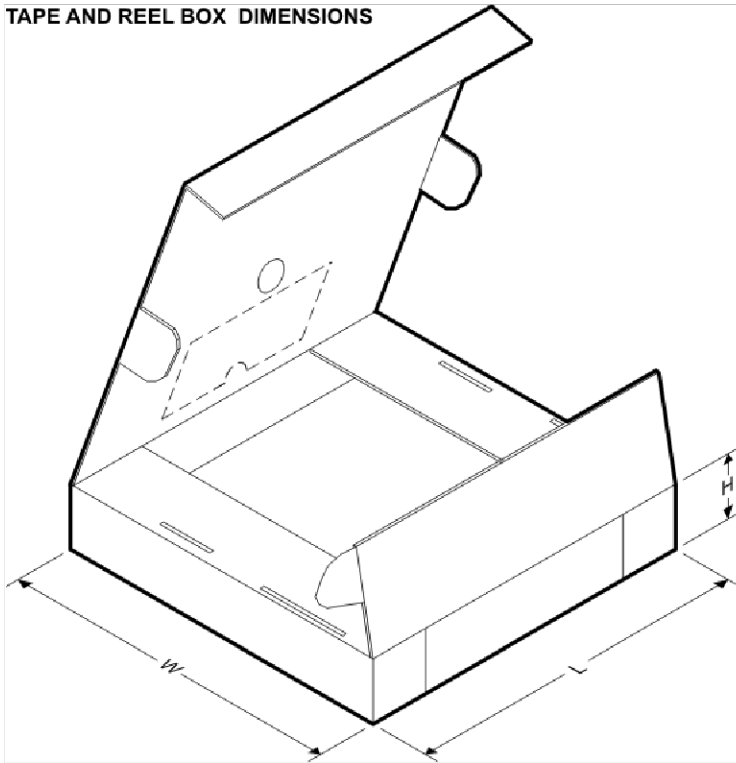
TAPE AND REEL BOX DIMENSIONS

*All dimensions are nominal

Device	Package Type	Package Drawing	Pins	SPQ	Length (mm)	Width (mm)	Height (mm)
TL783CKTTR	DDPAK/TO-263	KTT	3	500	350.0	334.0	47.0
TL783CKTTR	DDPAK/TO-263	KTT	3	500	340.0	340.0	38.0

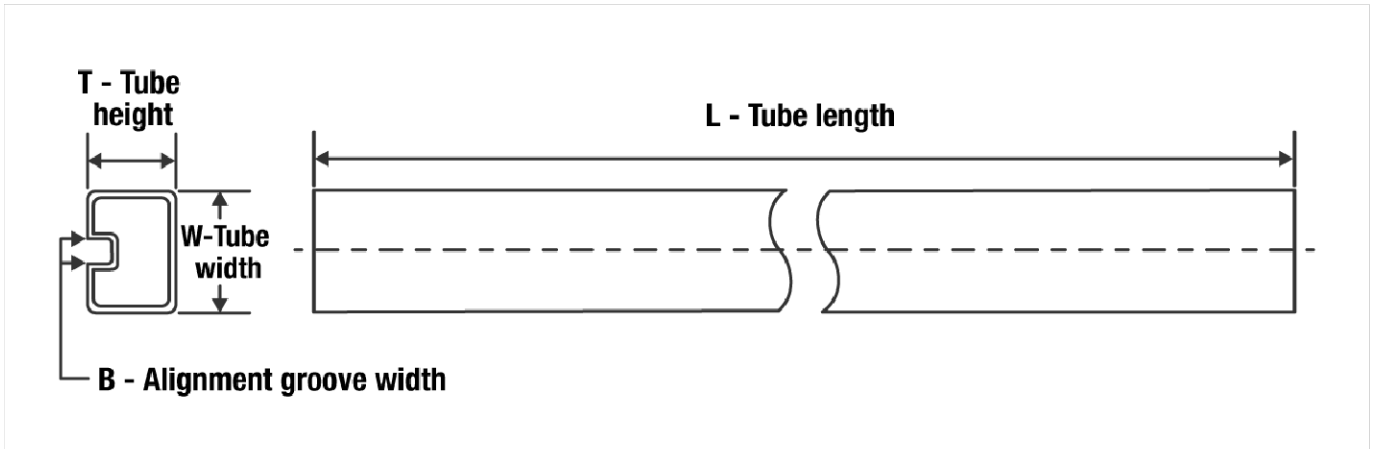
TUBE

*All dimensions are nominal

Device	Package Name	Package Type	Pins	SPQ	L (mm)	W (mm)	T (μm)	B (mm)
TL783CKCSE3	KCS	TO-220	3	50	532	34.1	700	9.6

KTT (R-PSFM-G3)

PLASTIC FLANGE-MOUNT PACKAGE

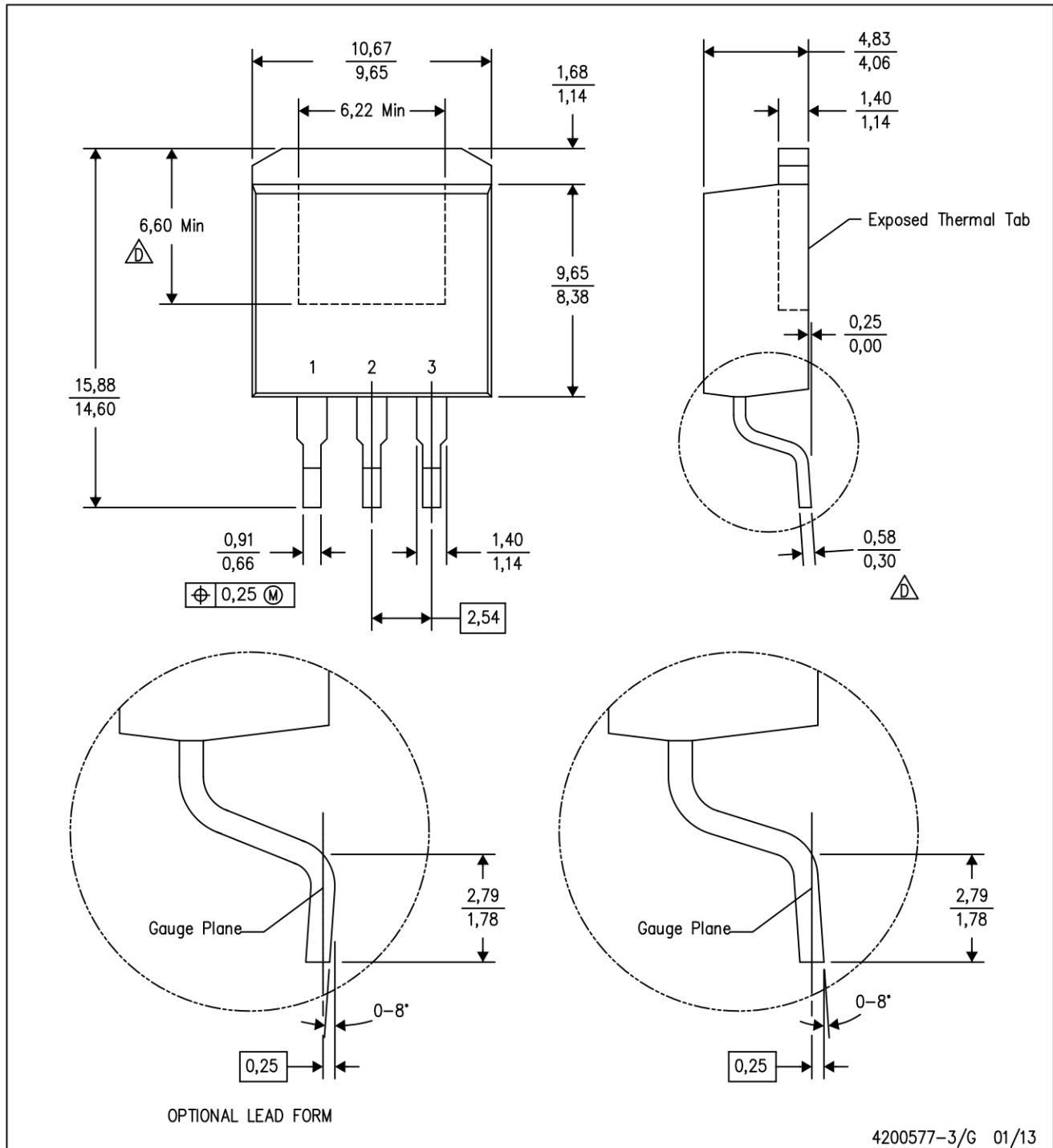

- NOTES:
- A. All linear dimensions are in millimeters.
 - B. This drawing is subject to change without notice.
 - C. Body dimensions do not include mold flash or protrusion. Mold flash or protrusion not to exceed 0.005 (0,13) per side.
- △ Falls within JEDEC TO-263 variation AA, except minimum lead thickness and minimum exposed pad length.

KTT (R-PSFM-G3)

PLASTIC FLANGE-MOUNT PACKAGE

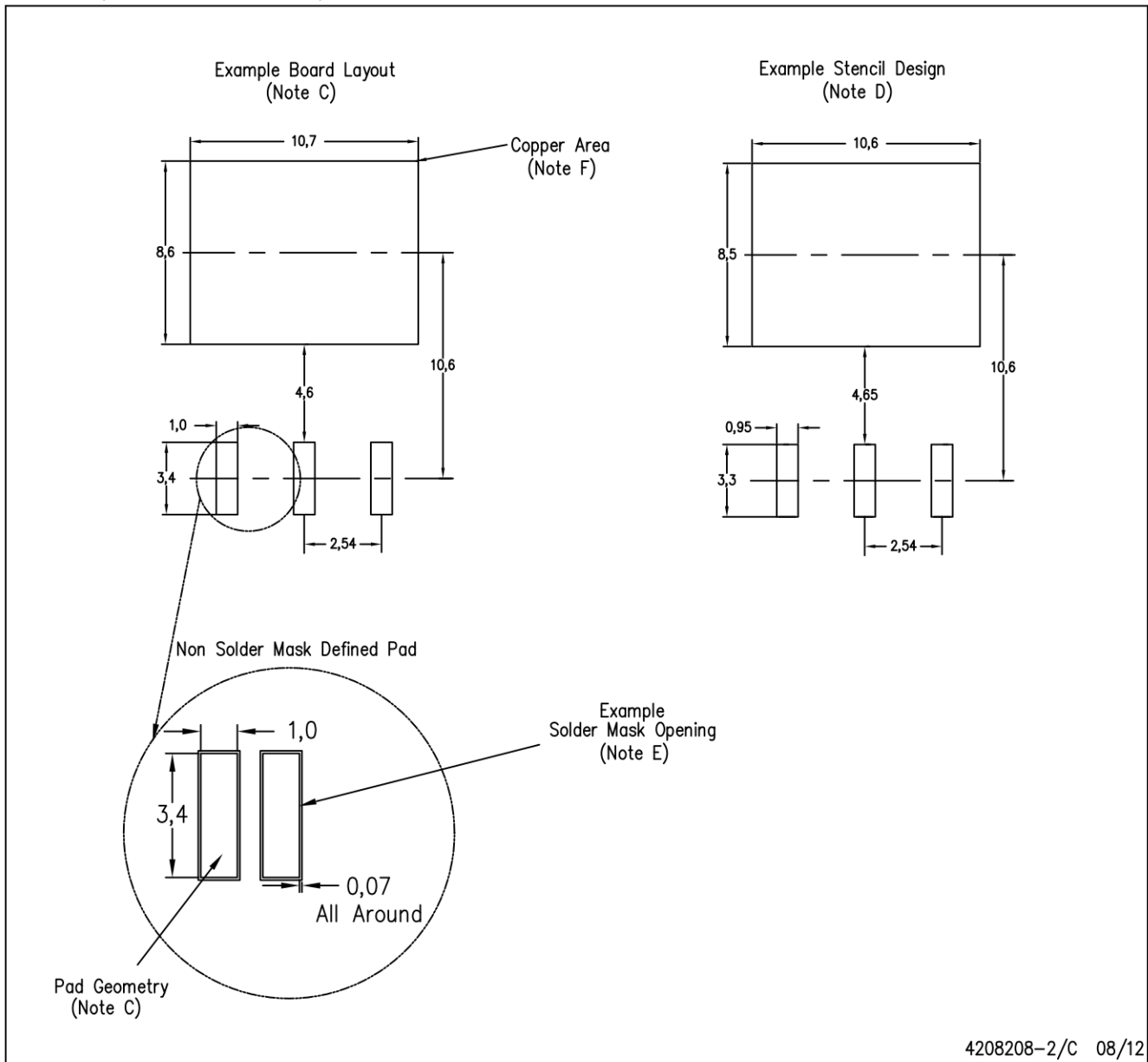

- NOTES:
- All linear dimensions are in millimeters.
 - This drawing is subject to change without notice.
 - Publication IPC-SM-782 is recommended for alternate designs.
 - Laser cutting apertures with trapezoidal walls and also rounding corners will offer better paste release. Customers should contact their board assembly site for stencil design recommendations. Refer to IPC-7525.
 - Customers should contact their board fabrication site for solder mask tolerances between and around signal pads.
 - This package is designed to be soldered to a thermal pad on the board. Refer to the Product Datasheet for specific thermal information, via requirements, and recommended thermal pad size. For thermal pad sizes larger than shown a solder mask defined pad is recommended in order to maintain the solderable pad geometry while increasing copper area.

KCS0003B

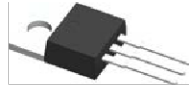

PACKAGE OUTLINE

TO-220 - 19.65 mm max height

TO-220

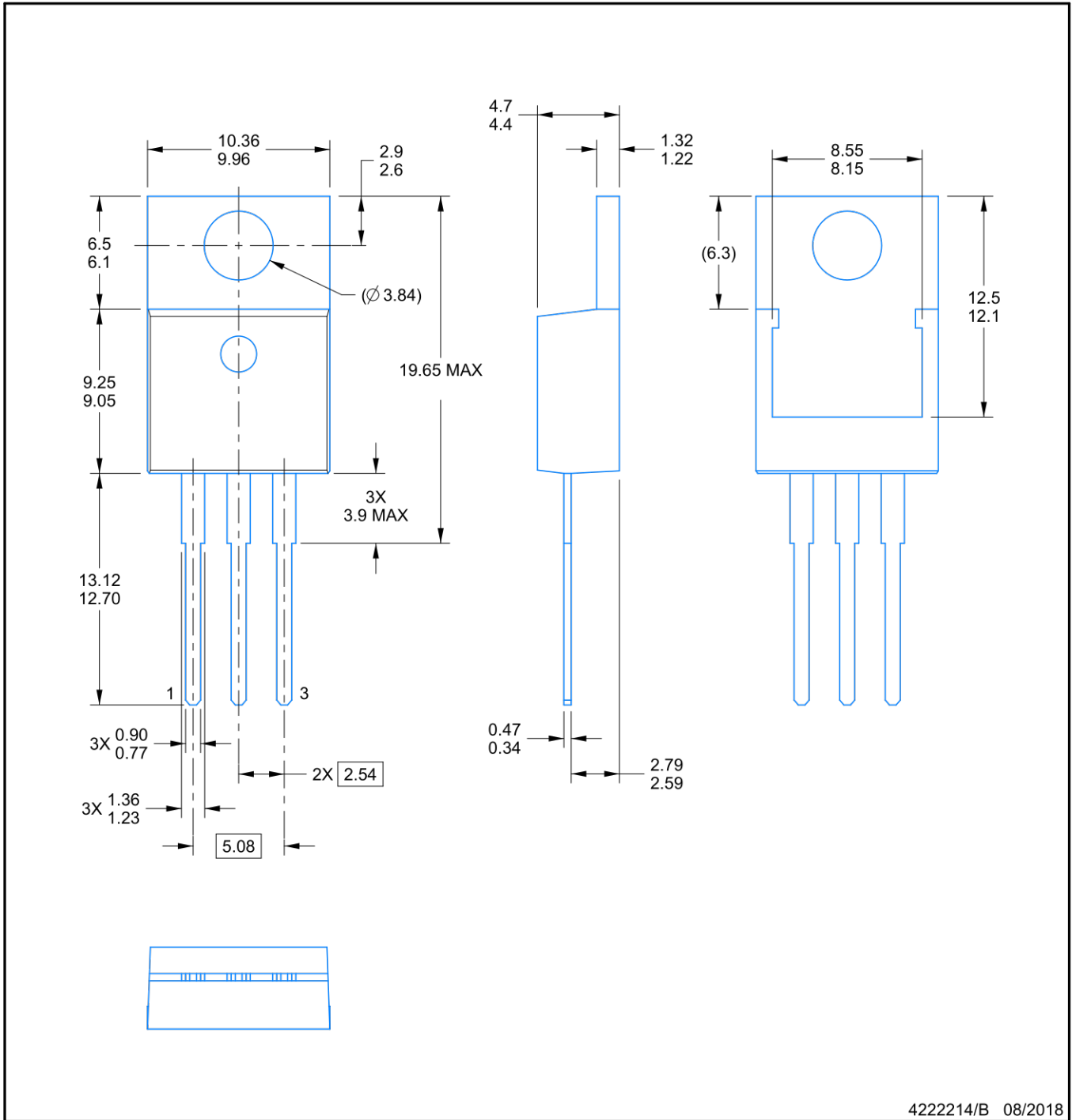

4222214/B 08/2018

NOTES:

1. Dimensions are in millimeters. Any dimension in brackets or parenthesis are for reference only. Dimensioning and tolerancing per ASME Y14.5M.
2. This drawing is subject to change without notice.
3. Reference JEDEC registration TO-220.

EXAMPLE BOARD LAYOUT

KCS0003B

TO-220 - 19.65 mm max height

TO-220

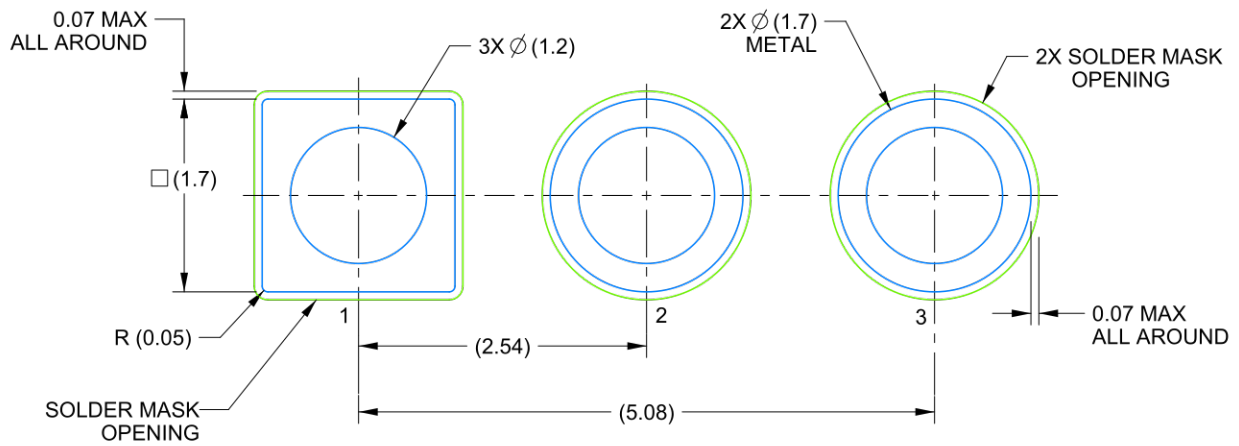

LAND PATTERN EXAMPLE
NON-SOLDER MASK DEFINED
SCALE:15X

4222214/B 08/2018

IMPORTANT NOTICE AND DISCLAIMER

TI PROVIDES TECHNICAL AND RELIABILITY DATA (INCLUDING DATA SHEETS), DESIGN RESOURCES (INCLUDING REFERENCE DESIGNS), APPLICATION OR OTHER DESIGN ADVICE, WEB TOOLS, SAFETY INFORMATION, AND OTHER RESOURCES "AS IS" AND WITH ALL FAULTS, AND DISCLAIMS ALL WARRANTIES, EXPRESS AND IMPLIED, INCLUDING WITHOUT LIMITATION ANY IMPLIED WARRANTIES OF MERCHANTABILITY, FITNESS FOR A PARTICULAR PURPOSE OR NON-INFRINGEMENT OF THIRD PARTY INTELLECTUAL PROPERTY RIGHTS.

These resources are intended for skilled developers designing with TI products. You are solely responsible for (1) selecting the appropriate TI products for your application, (2) designing, validating and testing your application, and (3) ensuring your application meets applicable standards, and any other safety, security, regulatory or other requirements.

These resources are subject to change without notice. TI grants you permission to use these resources only for development of an application that uses the TI products described in the resource. Other reproduction and display of these resources is prohibited. No license is granted to any other TI intellectual property right or to any third party intellectual property right. TI disclaims responsibility for, and you will fully indemnify TI and its representatives against, any claims, damages, costs, losses, and liabilities arising out of your use of these resources.

TI's products are provided subject to [TI's Terms of Sale](#) or other applicable terms available either on [ti.com](https://www.ti.com) or provided in conjunction with such TI products. TI's provision of these resources does not expand or otherwise alter TI's applicable warranties or warranty disclaimers for TI products.

TI objects to and rejects any additional or different terms you may have proposed. [IMPORTANT NOTICE](#)

Mailing Address: Texas Instruments, Post Office Box 655303, Dallas, Texas 75265
Copyright © 2024, Texas Instruments Incorporated