

## 2.7 V TO 5.5 V 12-BIT PARALLEL DIGITAL-TO-ANALOG CONVERTER WITH POWER DOWN

### FEATURES

- Single Supply 2.7-V to 5.5-V Operation
- $\pm 0.4$  LSB Differential Nonlinearity (DNL),  
 $\pm 1.5$  LSB Integral Nonlinearity (INL)
- 12-Bit Parallel Interface
- Compatible With TMS320 DSP
- Internal Power On Reset
- Settling Time 1  $\mu$ s Typ
- Low Power Consumption:
  - 8 mW for 5-V Supply
  - 4.3 mW for 3-V Supply
- Reference Input Buffers
- Voltage Output
- Monotonic Over Temperature
- Asynchronous Update

### APPLICATIONS

- Battery Powered Test Instruments
- Digital Offset and Gain Adjustment
- Battery Operated/Remote Industrial Controls
- Machine and Motion Control Devices
- Cordless and Wireless Telephones
- Speech Synthesis
- Communication Modulators
- Arbitrary Waveform Generation

### DESCRIPTION

The TLV5619 is a 12-bit voltage output DAC with a microprocessor and TMS320 compatible parallel interface. The 12 data bits are double buffered so that the output can be updated asynchronously using the LDAC pin. During normal operation, the device dissipates 8 mW at a 5-V supply and 4.3 mW at a 3-V supply. The power consumption can be lowered to 90 nW by setting the DAC to power-down mode.

The output voltage is buffered by a  $\times 2$  gain rail-to-rail amplifier, which features a Class A output stage to improve stability and reduce settling time.

**DW OR PW PACKAGE  
(TOP VIEW)**

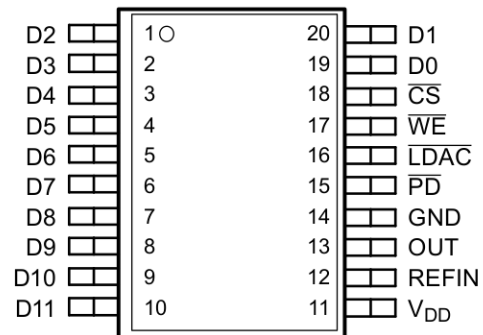

### AVAILABLE OPTIONS

T <sub>A</sub>	PACKAGE	
	SMALL OUTLINE (DW)	TSSOP (PW)
0°C to 70°C	TLV5619CDW	TLV5619CPW
40°C to 85°C	TLV5619IDW	TLV5619IPW
40°C to 125°C	TLV5619QDW	—



Please be aware that an important notice concerning availability, standard warranty, and use in critical applications of Texas Instruments semiconductor products and disclaimers thereto appears at the end of this data sheet.



These devices have limited built-in ESD protection. The leads should be shorted together or the device placed in conductive foam during storage or handling to prevent electrostatic damage to the MOS gates.

**FUNCTIONAL BLOCK DIAGRAM**

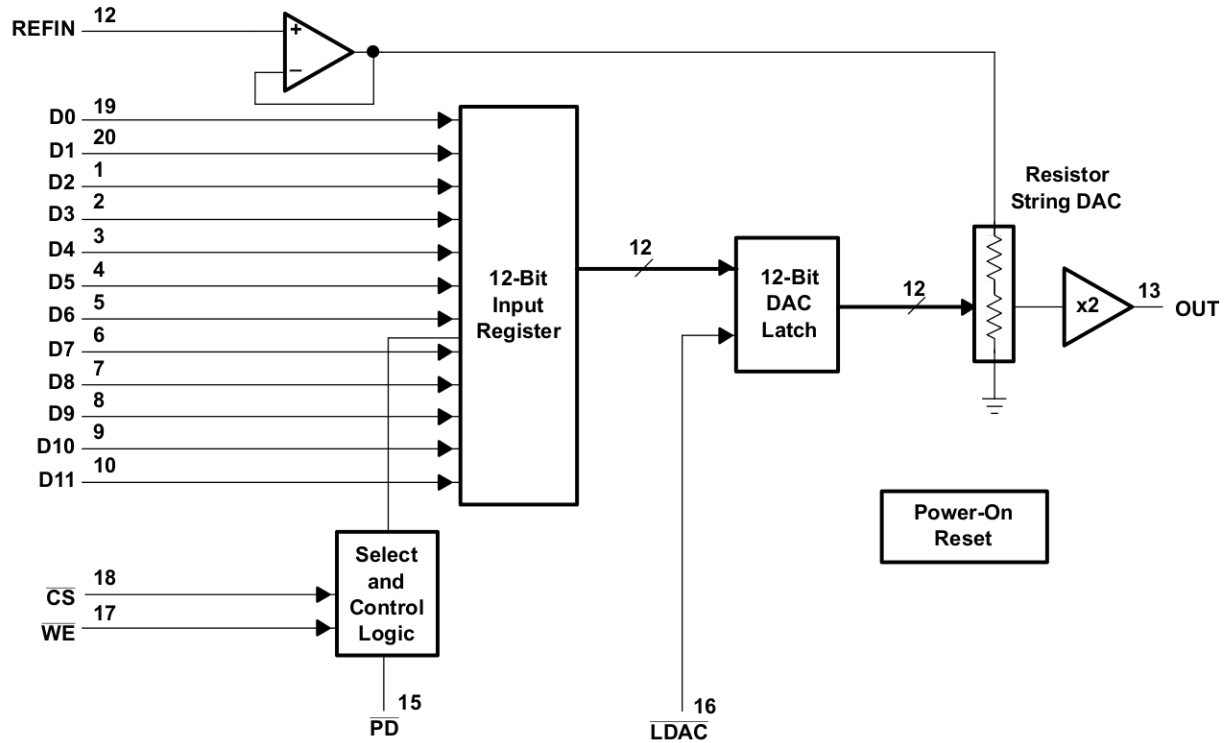

**Terminal Functions**

NAME	TERMINAL NO.	I/O	DESCRIPTION
$\overline{CS}$	18	I	Chip select
D0 (LSB)-D11 (MSB)	19, 20, 1-10	I	Parallel data input
GND	14		Ground
$\overline{LDAC}$	16	I	Load DAC
OUT	13	O	Analog output
$\overline{PD}$	15	I	When low, disables all buffer amplifier voltages to reduce supply current
REFIN	12	I	Voltage reference input
$V_{DD}$	11		Positive power supply
$\overline{WE}$	17	I	Write enable

**ABSOLUTE MAXIMUM RATINGS**

 over operating free-air temperature range (unless otherwise noted)<sup>(1)</sup>

		UNIT
Supply voltage ( $V_{DD}$ to GND)		7 V
Analog input voltage range		- 0.3 V to $V_{DD} + 0.3$ V
Reference input voltage		$V_{DD} + 0.3$ V
Digital input voltage range to GND		- 0.3 V to $V_{DD} + 0.3$ V
Operating free-air temperature range, $T_A$	TLV5619C	0°C to 70°C
	TLV5619I	-40°C to 85°C
	TLV5619Q	-40°C to 125°C
Storage temperature range, $T_{stg}$		-65°C to 150°C
Lead temperature 1,6 mm (1/16 inch) from case for 10 seconds		260°C

(1) Stresses beyond those listed under „ absolute maximum ratings” may cause permanent damage to the device. These are stress ratings only, and functional operation of the device at these or any other conditions beyond those indicated under „ recommended operating conditions” is not implied. Exposure to absolute-maximum-rated conditions for extended periods may affect device reliability.

**RECOMMENDED OPERATING CONDITIONS**

		MIN	NOM	MAX	UNIT
Supply voltage, $V_{DD}$ (5-V Supply)		4.5	5	5.5	V
Supply voltage, $V_{DD}$ (3-V Supply)		2.7	3	3.3	V
High-level digital input voltage, $V_{IH}$	$DV_{DD} = 2.7$ V	2			V
	$DV_{DD} = 5.5$ V	2.4			
Low-level digital input voltage, $V_{IL}$	$DV_{DD} = 2.7$ V	0.6			V
	$DV_{DD} = 5.5$ V	TLV5619C and TLV5619I		1	
		TLV5619Q		0.8	
Reference voltage, $V_{ref}$ to REFIN terminal (5-V Supply)		0	2.048	$V_{DD}-1.5$	V
Reference voltage, $V_{ref}$ to REFIN terminal (3-V Supply)		0	1.024	$V_{DD}-1.5$	V
Load resistance, $R_L$		2	10		k $\Omega$
Load capacitance, $C_L$				100	pF
Operating free-air temperature, $T_A$	TLV5619C	0		70	°C
	TLV5619I	40		85	
	TLV5619Q	40		125	

**ELECTRICAL CHARACTERISTICS**

over recommended operating free-air temperature range, supply voltages, and reference voltages (unless otherwise noted)

STATIC DAC SPECIFICATIONS							
PARAMETER		TEST CONDITIONS		MIN	TYP	MAX	UNIT
Resolution		$V_{\text{ref(REFIN)}} = 2.048 \text{ V at } 5 \text{ V, } 1.024 \text{ V at } 3 \text{ V}$		12			bits
Integral nonlinearity (INL)		$V_{\text{ref(REFIN)}} = 2.048 \text{ V at } 5 \text{ V, } 1.024 \text{ V at } 3 \text{ V,}$	See (1)		$\pm 1.5$	$\pm 4$	LSB
Differential nonlinearity (DNL)		$V_{\text{ref(REFIN)}} = 2.048 \text{ V at } 5 \text{ V, } 1.024 \text{ V at } 3 \text{ V,}$	See (2)		$\pm 0.4$	$\pm 1$	LSB
$E_{\text{ZS}}$	Zero-scale error (offset error at zero scale)	$V_{\text{ref(REFIN)}} = 2.048 \text{ V at } 5 \text{ V, } 1.024 \text{ V at } 3 \text{ V,}$	See (3)		$\pm 3$	$\pm 20$	mV
Zero-scale-error temperature coefficient		$V_{\text{ref(REFIN)}} = 2.048 \text{ V at } 5 \text{ V, } 1.024 \text{ V at } 3 \text{ V,}$	See (4)		3		ppm/°C
$E_{\text{G}}$	Gain error	$V_{\text{ref(REFIN)}} = 2.048 \text{ V at } 5 \text{ V, } 1.024 \text{ V at } 3 \text{ V,}$	See (5)		$\pm 0.25$	$\pm 0.5$	% of FS voltage
Gain error temperature coefficient		$V_{\text{ref(REFIN)}} = 2.048 \text{ V at } 5 \text{ V, } 1.024 \text{ V at } 3 \text{ V,}$	See (6)		1		ppm/°C
PSRR	Power-supply rejection ratio	Zero scale	See (7) and (8)		65		dB
		Gain			65		

- (1) The relative accuracy or integral nonlinearity (INL), sometimes referred to as linearity error, is the maximum deviation of the output from the line between zero and full scale excluding the effects of zero code and full-scale errors.
- (2) The differential nonlinearity (DNL), sometimes referred to as differential error, is the difference between the measured and ideal 1 LSB amplitude change of any two adjacent codes. Monotonic means the output voltage changes in the same direction (or remains constant) as a change in the digital input code.
- (3) Zero-scale error is the deviation from zero voltage output when the digital input code is zero.
- (4) Zero-scale-error temperature coefficient is given by:  $E_{\text{ZS}} \text{ TC} = [E_{\text{ZS}}(T_{\text{max}}) - E_{\text{ZS}}(T_{\text{min}})]/V_{\text{ref}} \times 10^6/(T_{\text{max}} - T_{\text{min}})$ .
- (5) Gain error is the deviation from the ideal output ( $2 \times V_{\text{ref}} - 1$  LSB) with an output load of 10 k $\Omega$  excluding the effects of the zero-error.
- (6) Gain temperature coefficient is given by:  $E_{\text{G}} \text{ TC} = [E_{\text{G}}(T_{\text{max}}) - E_{\text{G}}(T_{\text{min}})]/V_{\text{ref}} \times 10^6/(T_{\text{max}} - T_{\text{min}})$ .
- (7) Zero-scale-error rejection ratio (EZS-RR) is measured by varying the  $V_{\text{DD}}$  from 4.5 V to 5.5 V dc and measuring the proportion of this signal imposed on the zero-code output voltage.
- (8) Gain-error rejection ratio (EG-RR) is measured by varying the  $V_{\text{DD}}$  from 4.5 V to 5.5 V dc and measuring the proportion of this signal imposed on the full-scale output voltage after subtracting the zero scale change.

OUTPUT SPECIFICATIONS							
PARAMETER		TEST CONDITIONS		MIN	TYP	MAX	UNIT
$V_{\text{O}}$	Voltage output range	$R_{\text{L}} = 10 \text{ k}\Omega$		0		$V_{\text{DD}} - 0.4$	V
Output load regulation accuracy		$V_{\text{O(OUT)}} = 4.096 \text{ V, } 2.048 \text{ V}$	$R_{\text{L}} = 2 \text{ k}\Omega$		0.1	0.29	% of FS voltage
$I_{\text{OSC(source)}}$	Output short circuit source current	$V_{\text{O(OUT)}} = 0 \text{ V, Full scale code}$	5-V Supply		100		mA
			3-V Supply		25		
$I_{\text{O(source)}}$	Output source current	$R_{\text{L}} = 100\Omega$	5-V Supply		10		mA
			3-V Supply		10		

REFERENCE INPUT (REFIN)						
PARAMETER		TEST CONDITIONS	MIN	TYP	MAX	UNIT
$V_{ref}$	Reference input voltage	See (1)	0		$V_{DD}-1.5$	V
$R_i$	Reference input resistance			10		M $\Omega$
$C_i$	Reference input capacitance			5		pF
	Reference feed through	REFIN = 1 $V_{pp}$ at 1 kHz + 1.024 V dc (see (2))		60		dB
	Reference input bandwidth	REFIN = 0.2 $V_{pp}$ + 1.024 V dc at -3 dB		1.4		MHz
DIGITAL INPUTS ( $\overline{D0-D11}$ , $\overline{CS}$ , $\overline{WE}$ , $\overline{LDAC}$ , $\overline{PD}$ )						
$I_{IH}$	High-level digital input current	$V_i = V_{DD}$			1	$\mu$ A
$I_{IL}$	Low-level digital input current	$V_i = 0$ V			1	$\mu$ A
$C_i$	Input capacitance			8		pF

(1) Reference input voltages greater than  $V_{DD}/2$  will cause output saturation for large DAC codes.

(2) Reference feedthrough is measured at the DAC output with an input code = 0x000 and a  $V_{ref(REFIN)}$  input = 1.024 V dc + 1  $V_{pp}$  at 1 kHz.

POWER SUPPLY						
PARAMETER		TEST CONDITIONS	MIN	TYP	MAX	UNIT
$I_{DD}$	Power supply current	No load, All inputs 0 V or $V_{DD}$	5-V Supply	1.6	3	mA
			3-V Supply	1.44	2.7	
	Power down supply current			0.01	10	$\mu$ A

ANALOG OUTPUT DYNAMIC PERFORMANCE						
PARAMETER		TEST CONDITIONS	MIN	TYP	MAX	UNIT
SR	Slew rate	$C_L = 100$ pF, $R_L = 10$ k $\Omega$ $V_{ref(REFIN)} = 2.048$ V, $V_{ref(REFIN)} = 1.024$ V, $V_O$ from 10% to 90% $V_O$ from 90% to 10%	5-V Supply	8	12	V/ $\mu$ s
			3-V Supply	6	9	V/ $\mu$ s
$t_s$	Output settling time (full scale)	To $\pm 0.5$ LSB, $R_L = 10$ k $\Omega$ , $C_L = 100$ pF, See (1)		1	3	$\mu$ s
	Glitch energy	DIN = all 0s to all 1s		5		nV-s
S/N	Signal to noise	$f_s = 480$ kSPS, BW = 20 kHz, $C_L = 100$ pF, $f_{OUT} = 1$ kHz, $R_L = 10$ k $\Omega$ , $T_A = 25^\circ$ C, See (2)	5-V Supply	65	78	dB
S/(N+D)	Signal to noise + distortion	$f_s = 480$ kSPS, BW = 20 kHz, $C_L = 100$ pF, $f_{OUT} = 1$ kHz, $R_L = 10$ k $\Omega$ , $T_A = 25^\circ$ C, See (2)	5-V Supply	58	67	
			3-V Supply	58	69	
	Total harmonic distortion	$f_s = 480$ kSPS, BW = 20 kHz, $C_L = 100$ pF, $f_{OUT} = 1$ kHz, $R_L = 10$ k $\Omega$ , $T_A = 25^\circ$ C, See (2)		68	60	
	Spurious free dynamic range	$f_s = 480$ kSPS, BW = 20 kHz, $C_L = 100$ pF, $f_{OUT} = 1$ kHz, $R_L = 10$ k $\Omega$ , $T_A = 25^\circ$ C, See (2)		60	72	

(1) Settling time is the time for the output signal to remain within  $\pm 0.5$  LSB of the final measured value for a digital input code change of 32 to 4063 or 4063 to 32. Limits are ensured by design and characterization, but are not production tested.

(2) 1 kHz sinewave generated by DAC, reference voltage = 1.024 V at 3 V and 2.048 V at 5 V.

## TIMING REQUIREMENTS

DIGITAL INPUTS					
		MIN	NOM	MAX	UNIT
$t_{su(CS-WE)}$	Setup time, $\overline{CS}$ low before positive $\overline{WE}$ edge	13			ns
$t_{su(D)}$	Setup time, data ready before positive $\overline{WE}$ edge	9			ns
$t_{h(D)}$	Hold time, data held after positive $\overline{WE}$ edge	0			ns
$t_{su(WE-LD)}$	Setup time, positive $\overline{WE}$ edge before $\overline{LDAC}$ low	0			ns
$t_{wh(WE)}$	Pulse width, $\overline{WE}$ high	25			ns
$t_{w(LD)}$	Pulse width, $\overline{LDAC}$ low	25			ns

PARAMETER MEASUREMENT INFORMATION

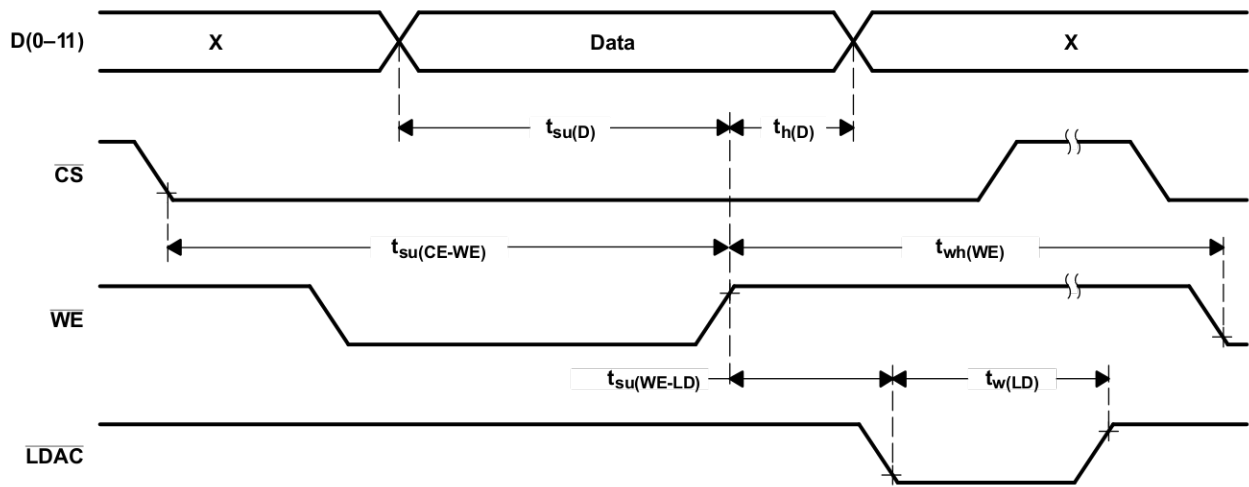

Figure 1. Timing Diagram

**TYPICAL CHARACTERISTICS**

**MAXIMUM OUTPUT VOLTAGE  
vs  
LOAD**

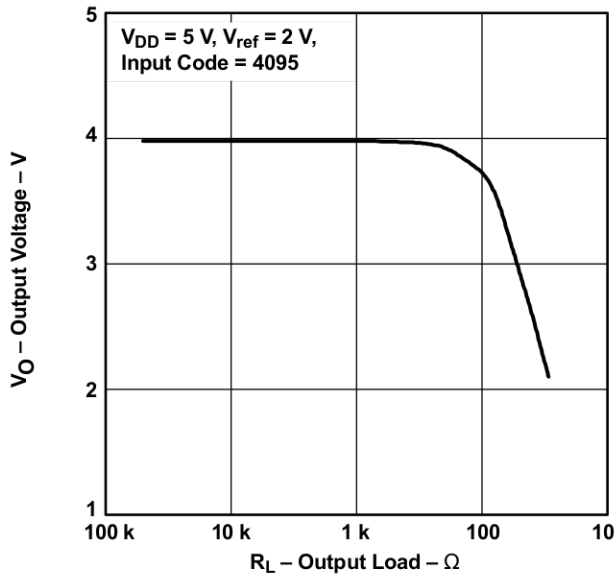

Figure 2.

**MAXIMUM OUTPUT VOLTAGE  
vs  
LOAD**

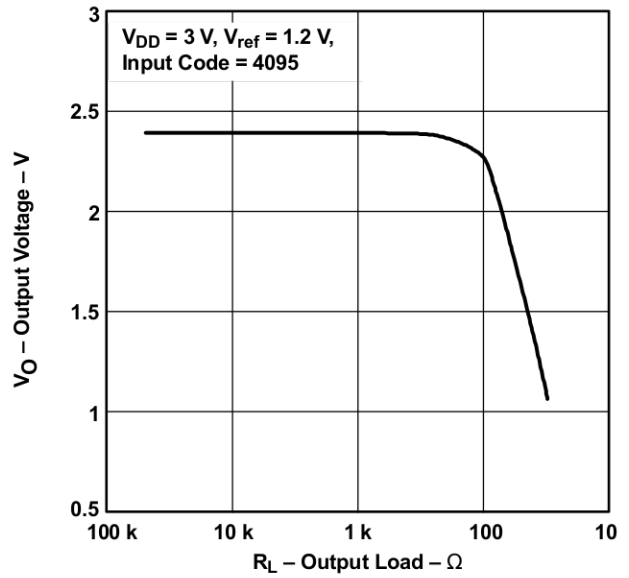

Figure 3.

**TOTAL HARMONIC DISTORTION  
vs  
LOAD**

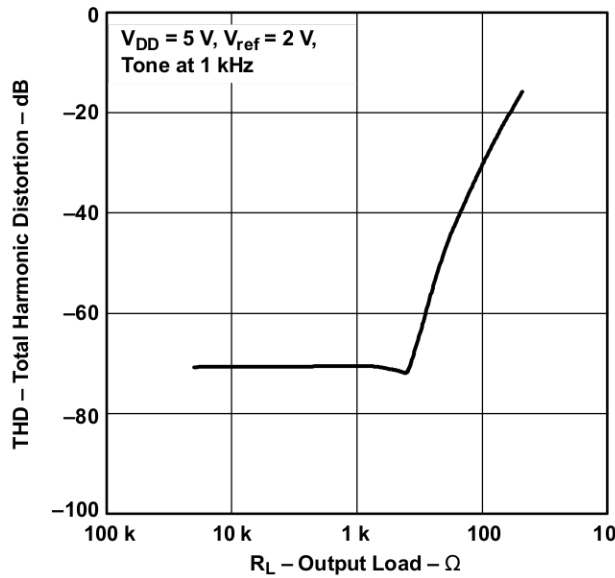

Figure 4.

**TOTAL HARMONIC DISTORTION  
vs  
FREQUENCY**

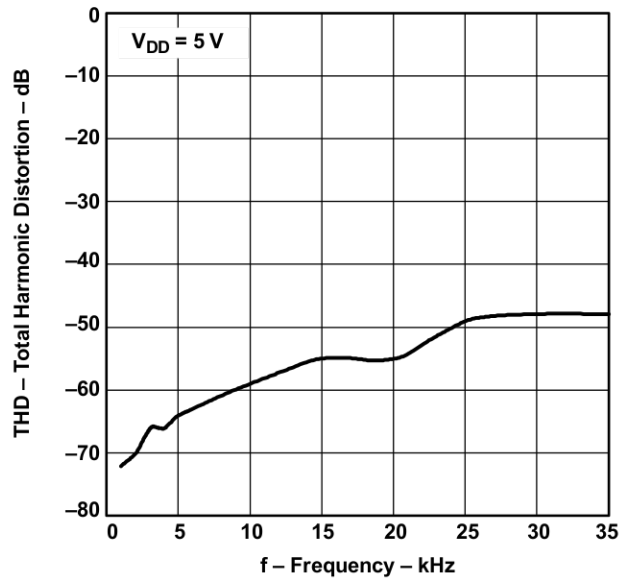

Figure 5.

TYPICAL CHARACTERISTICS (continued)

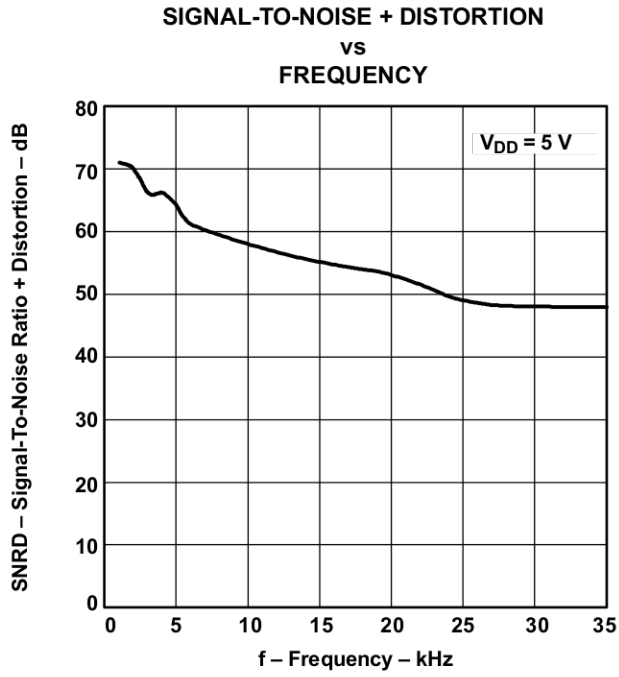

Figure 6.

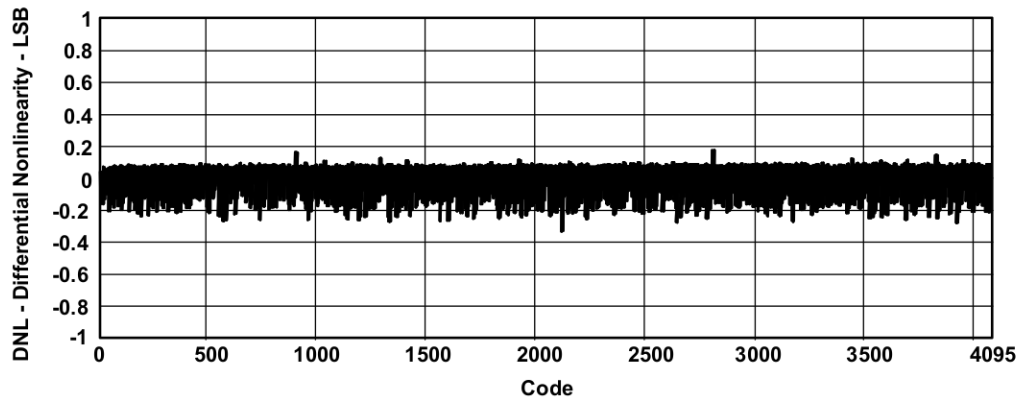

Figure 7. Differential Nonlinearity

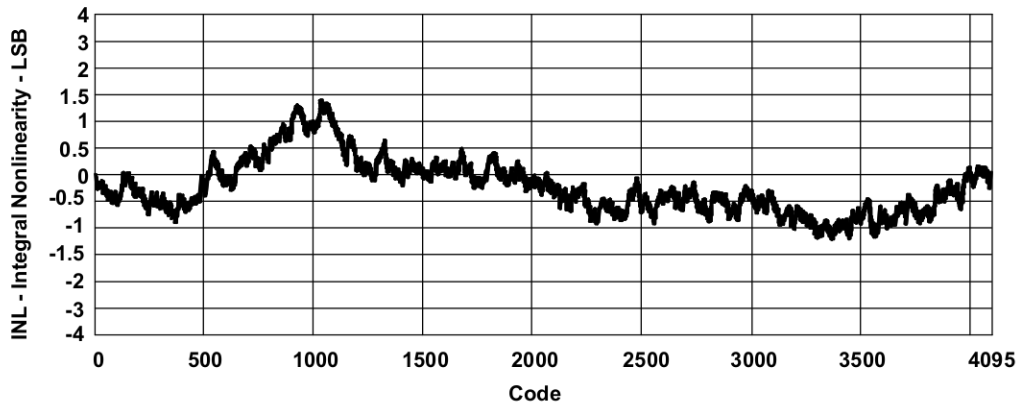

Figure 8. Integral Nonlinearity



TYPICAL CHARACTERISTICS (continued)

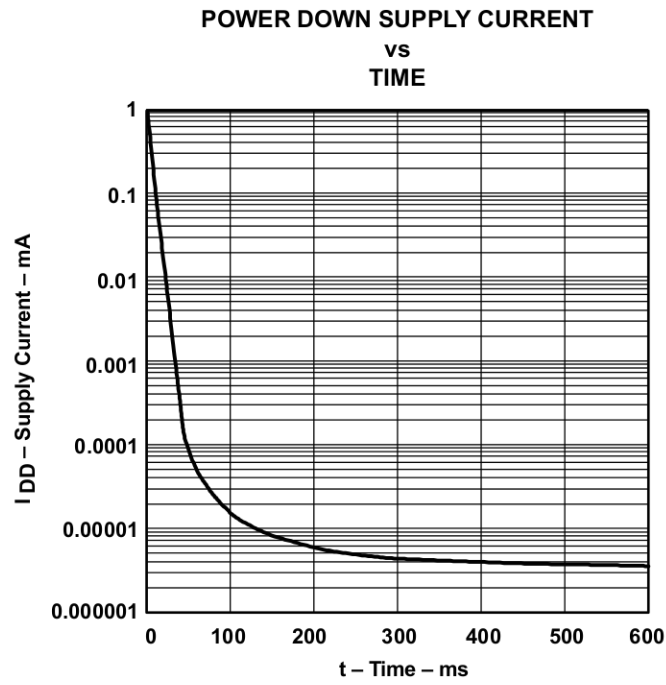

Figure 9.

## APPLICATION INFORMATION

### DEFINITIONS OF SPECIFICATIONS AND TERMINOLOGY

#### **Integral Nonlinearity (INL)**

The relative accuracy or integral nonlinearity (INL), sometimes referred to as linearity error, is the maximum deviation of the output from the line between zero and full scale excluding the effects of zero code and full-scale errors.

#### **Differential Nonlinearity (DNL)**

The differential nonlinearity (DNL), sometimes referred to as differential error, is the difference between the measured and ideal 1 LSB amplitude change of any two adjacent codes. Monotonic means the output voltage changes in the same direction (or remains constant) as a change in the digital input code.

#### **Zero-Scale Error ( $E_{ZS}$ )**

Zero-scale error is defined as the deviation of the output from 0 V at a digital input value of 0.

#### **Gain Error ( $E_G$ )**

Gain error is the error in slope of the DAC transfer function.

#### **Signal-to-Noise Ratio + Distortion (S/N+D)**

S/N+D is the ratio of the rms value of the output signal to the rms sum of all other spectral components below the Nyquist frequency, including harmonics but excluding dc. The value for S/N+D is expressed in decibels.

#### **Spurious Free Dynamic Range (SFDR)**

SFDR is the difference between the rms value of the output signal and the rms value of the largest spurious signal within a specified bandwidth. The value for SFDR is expressed in decibels.

#### **Total Harmonic Distortion (THD)**

THD is the ratio of the rms sum of the first six harmonic components to the rms value of the fundamental signal and is expressed in decibels.

**APPLICATION INFORMATION (continued)**

**LINEARITY, OFFSET, AND GAIN ERROR USING SINGLE END SUPPLIES**

When an amplifier is operated from a single supply, the voltage offset can still be either positive or negative. With a positive offset, the output voltage changes on the first code change. With a negative offset the output voltage may not change with the first code depending on the magnitude of the offset voltage.

The output amplifier attempts to drive the output to a negative voltage. However, because the most negative supply rail is ground, the output cannot drive below ground and clamps the output at 0 V.

The output voltage remains at zero until the input code value produces a sufficient positive output voltage to overcome the negative offset voltage, resulting in the transfer function shown in Figure 10.

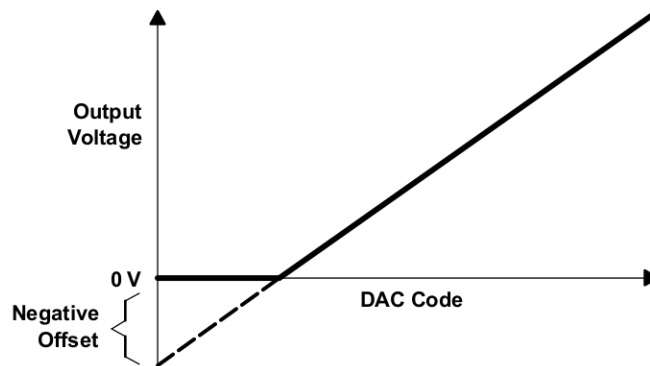

**Figure 10. Effect of Negative Offset (Single Supply)**

This offset error, not the linearity error, produces this breakpoint. The transfer function would have followed the dotted line if the output buffer could drive below the ground rail.

For a DAC, linearity is measured between zero input code (all inputs 0) and full scale code (all inputs 1) after offset and full scale are adjusted out or accounted for in some way. However, single supply operation does not allow for adjustment when the offset is negative due to the breakpoint in the transfer function. So the linearity is measured between full scale code and the lowest code that produces a positive output voltage.

**GENERAL FUNCTION**

The TLV5619 is a 12-bit, single supply DAC, based on a resistor string architecture. It consists of a parallel interface, a power down control logic, a resistor string, and a rail-to-rail output buffer. The output voltage (full scale determined by reference) is given by:

$$2 \text{ REF } \frac{\text{CODE}}{0x1000} \text{ [V]}$$

Where REF is the reference voltage and CODE is the digital input value, range 0x000 to 0xFFF. A power on reset initially puts the internal latches to a defined state (all bits zero).

**APPLICATION INFORMATION (continued)**

**PARALLEL INTERFACE**

The device latches data on the positive edge of  $\overline{WE}$ . It must be enabled with  $\overline{CS}$  low.  $\overline{LDAC}$  low updates the DAC with the value in the holding latch.  $\overline{LDAC}$  is an asynchronous input and can be held low, if a separate update is not necessary. However, to control the DAC using the load feature,  $\overline{LDAC}$  can be driven low after the positive  $\overline{WE}$  edge.

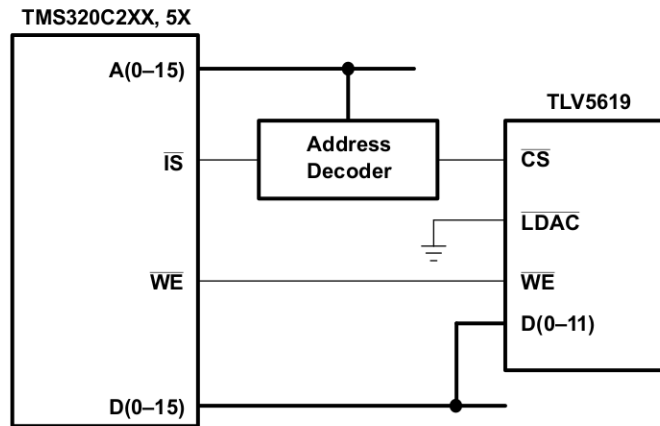

Figure 11. Proposed Interface Between TLV5619 and TMS320C2XX, 5X DSPs

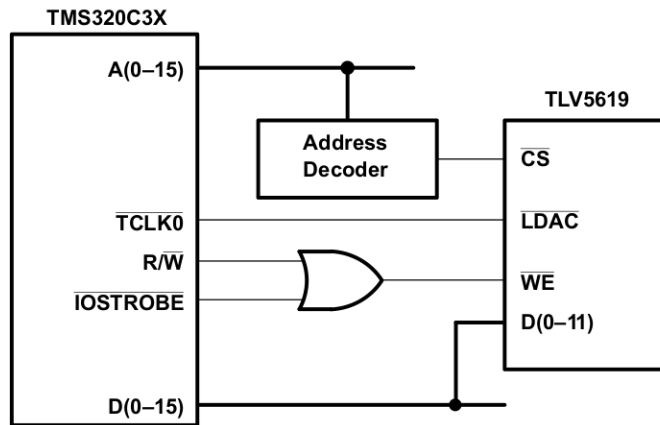

Figure 12. Proposed Interface Between TLV5619 and TMS320C3X DSPs

**APPLICATION INFORMATION (continued)**

**TLV5619 INTERFACED TO TMS320C203 DSP**

**Hardware Interface**

Figure 13 shows an example of the connection between the TLV5619 and the TMS320C203 DSP. The only other device that is needed in addition to the DSP and the DAC is the 74AC138 address decoding circuit. Using this configuration, the DAC address is 0x0084 within the I/O memory space of the TMS320C203.

$\overline{\text{LDAC}}$  is held low so that the output voltage is updated with the rising  $\overline{\text{WE}}$  edge. The power down mode is deactivated permanently by pulling  $\overline{\text{PD}}$  to  $V_{\text{DD}}$ .

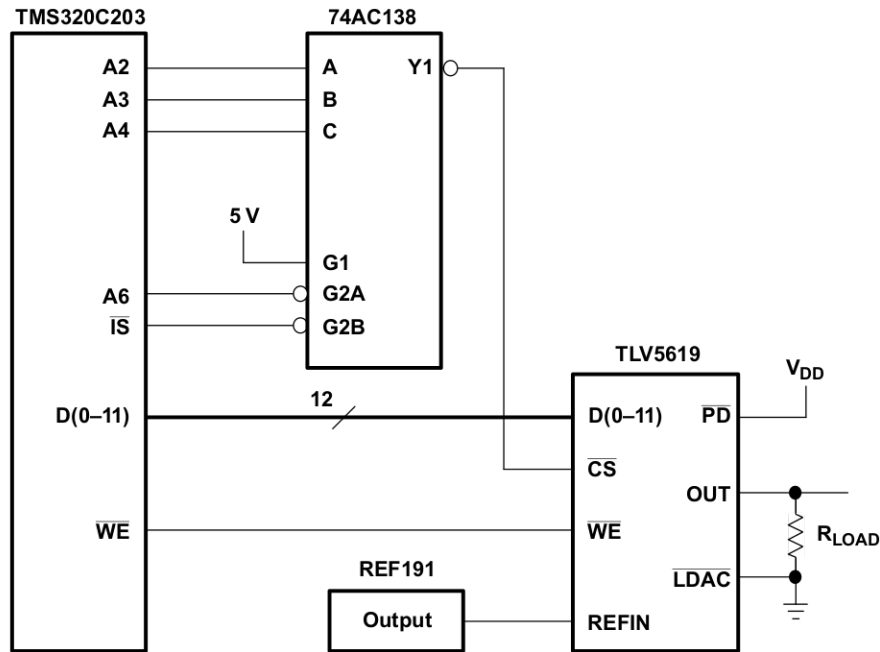

**Figure 13. TLV5619 to TMS320C203 DSP Interface Connection**

**Software**

No setup procedure is needed to access the TLV5619. The output voltage can be set using one command:  
`out data_addr, DAC_addr`

Where `data_addr` points to the address location (in this example 0x0060) holding the new output voltage data and `DAC_addr` is the I/O space address of the TLV5619 (in this example 0x0084).

The following code shows, how to use the timer of the TMS320C203 as a time base to generate a voltage ramp with the TLV5619. A timer interrupt is generated every 205  $\mu\text{s}$ . The corresponding interrupt service routine increments the output code (stored at 0x0060) for the DAC and writes the new code to the TLV5619. Only the 12 LSBs of the data in 0x0060 are used by the DAC, so that the resulting period of the saw waveform is:

- $t = 4096 \times 205 \text{ E-6 s} = 0.84 \text{ s}$

**APPLICATION INFORMATION (continued)****SOFTWARE LISTING**

```

; File: ramp.asm
; Description: This program generates a ramp.

;----- I/O and memory mapped regs -----
TLV5619      .include "regs.asm"
              .equ    0084h
;----- vectors -----
              .ps     0h
              b       start
              b       INT1
              b       INT23
              b       TIM_ISR

*****
* Main Program
*****

              .ps     1000h
              .entry

start:
              ldp     #0      ; set data page to 0
; disable interrupts
              setc    INTM    ; disable maskable interrupts
              splk   #0ffffh, IFR
              splk   #0004h,  IMR

; set up the timer
              splk   #0000h,   60h
              splk   #0042h,   61h
              out    61h, PRD
              out    60h, TIM
              splk   #0c2fh,   62h
              out    62h, TCR

; enable interrupts
              clrc   INTM    ; enable maskable interrupts

; loop forever!
next         idle      ; wait for interrupt
              b      next
; all else fails stop here
done         b      done ; hang there

*****
* Interrupt Service Routines
*****

INT1:        ret        ; do nothing and return

INT23:       ret        ; do nothing and return

TIM_ISR:
              ; useful code
              add    #1h ; increment accumulator
              sacl   60h

```

**APPLICATION INFORMATION (continued)**

```
out      60h, TLV5619 ; write to DAC
clrc     intm; re-enable interrupts
ret      ; return from interrupt
.end
```

**PACKAGING INFORMATION**

Orderable Device	Status (1)	Package Type	Package Drawing	Pins	Package Qty	Eco Plan (2)	Lead/Ball Finish (6)	MSL Peak Temp (3)	Op Temp (°C)	Device Marking (4/5)	Samples
TLV5619CDW	ACTIVE	SOIC	DW	20	25	Green (RoHS & no Sb/Br)	NIPDAU	Level-1-260C-UNLIM	0 to 70	TLV5619C	<a href="#">Samples</a>
TLV5619CDWR	ACTIVE	SOIC	DW	20	2000	Green (RoHS & no Sb/Br)	NIPDAU	Level-1-260C-UNLIM	0 to 70	TLV5619C	<a href="#">Samples</a>
TLV5619CPW	ACTIVE	TSSOP	PW	20	70	Green (RoHS & no Sb/Br)	NIPDAU	Level-1-260C-UNLIM	0 to 70	TV5619	<a href="#">Samples</a>
TLV5619CPWR	ACTIVE	TSSOP	PW	20	2000	Green (RoHS & no Sb/Br)	NIPDAU	Level-1-260C-UNLIM	0 to 70	TV5619	<a href="#">Samples</a>
TLV5619IDW	ACTIVE	SOIC	DW	20	25	Green (RoHS & no Sb/Br)	NIPDAU	Level-1-260C-UNLIM	-40 to 85	TLV5619I	<a href="#">Samples</a>
TLV5619IDWG4	ACTIVE	SOIC	DW	20	25	Green (RoHS & no Sb/Br)	NIPDAU	Level-1-260C-UNLIM	-40 to 85	TLV5619I	<a href="#">Samples</a>
TLV5619IDWR	ACTIVE	SOIC	DW	20	2000	Green (RoHS & no Sb/Br)	NIPDAU	Level-1-260C-UNLIM	-40 to 85	TLV5619I	<a href="#">Samples</a>
TLV5619IPW	ACTIVE	TSSOP	PW	20	70	Green (RoHS & no Sb/Br)	NIPDAU	Level-1-260C-UNLIM	-40 to 85	TY5619	<a href="#">Samples</a>
TLV5619IPWG4	ACTIVE	TSSOP	PW	20	70	Green (RoHS & no Sb/Br)	NIPDAU	Level-1-260C-UNLIM	-40 to 85	TY5619	<a href="#">Samples</a>
TLV5619IPWR	ACTIVE	TSSOP	PW	20	2000	Green (RoHS & no Sb/Br)	NIPDAU	Level-1-260C-UNLIM	-40 to 85	TY5619	<a href="#">Samples</a>
TLV5619QDWG4	ACTIVE	SOIC	DW	20	25	Green (RoHS & no Sb/Br)	NIPDAU	Level-1-260C-UNLIM		TLV5619Q	<a href="#">Samples</a>

(1) The marketing status values are defined as follows:

**ACTIVE:** Product device recommended for new designs.

**LIFEBUY:** TI has announced that the device will be discontinued, and a lifetime-buy period is in effect.

**NRND:** Not recommended for new designs. Device is in production to support existing customers, but TI does not recommend using this part in a new design.

**PREVIEW:** Device has been announced but is not in production. Samples may or may not be available.

**OBSOLETE:** TI has discontinued the production of the device.

(2) **RoHS:** TI defines "RoHS" to mean semiconductor products that are compliant with the current EU RoHS requirements for all 10 RoHS substances, including the requirement that RoHS substance do not exceed 0.1% by weight in homogeneous materials. Where designed to be soldered at high temperatures, "RoHS" products are suitable for use in specified lead-free processes. TI may reference these types of products as "Pb-Free".

**RoHS Exempt:** TI defines "RoHS Exempt" to mean products that contain lead but are compliant with EU RoHS pursuant to a specific EU RoHS exemption.

**Green:** TI defines "Green" to mean the content of Chlorine (Cl) and Bromine (Br) based flame retardants meet JS709B low halogen requirements of <=1000ppm threshold. Antimony trioxide based flame retardants must also meet the <=1000ppm threshold requirement.



- (3) MSL, Peak Temp. - The Moisture Sensitivity Level rating according to the JEDEC industry standard classifications, and peak solder temperature.
- (4) There may be additional marking, which relates to the logo, the lot trace code information, or the environmental category on the device.
- (5) Multiple Device Markings will be inside parentheses. Only one Device Marking contained in parentheses and separated by a "~" will appear on a device. If a line is indented then it is a continuation of the previous line and the two combined represent the entire Device Marking for that device.
- (6) Lead/Ball Finish - Orderable Devices may have multiple material finish options. Finish options are separated by a vertical ruled line. Lead/Ball Finish values may wrap to two lines if the finish value exceeds the maximum column width.

**Important Information and Disclaimer:**The information provided on this page represents TI's knowledge and belief as of the date that it is provided. TI bases its knowledge and belief on information provided by third parties, and makes no representation or warranty as to the accuracy of such information. Efforts are underway to better integrate information from third parties. TI has taken and continues to take reasonable steps to provide representative and accurate information but may not have conducted destructive testing or chemical analysis on incoming materials and chemicals. TI and TI suppliers consider certain information to be proprietary, and thus CAS numbers and other limited information may not be available for release.

In no event shall TI's liability arising out of such information exceed the total purchase price of the TI part(s) at issue in this document sold by TI to Customer on an annual basis.

**OTHER QUALIFIED VERSIONS OF TLV5619 :**

- Enhanced Product: [TLV5619-EP](#)

NOTE: Qualified Version Definitions:

- Enhanced Product - Supports Defense, Aerospace and Medical Applications

## TAPE AND REEL INFORMATION

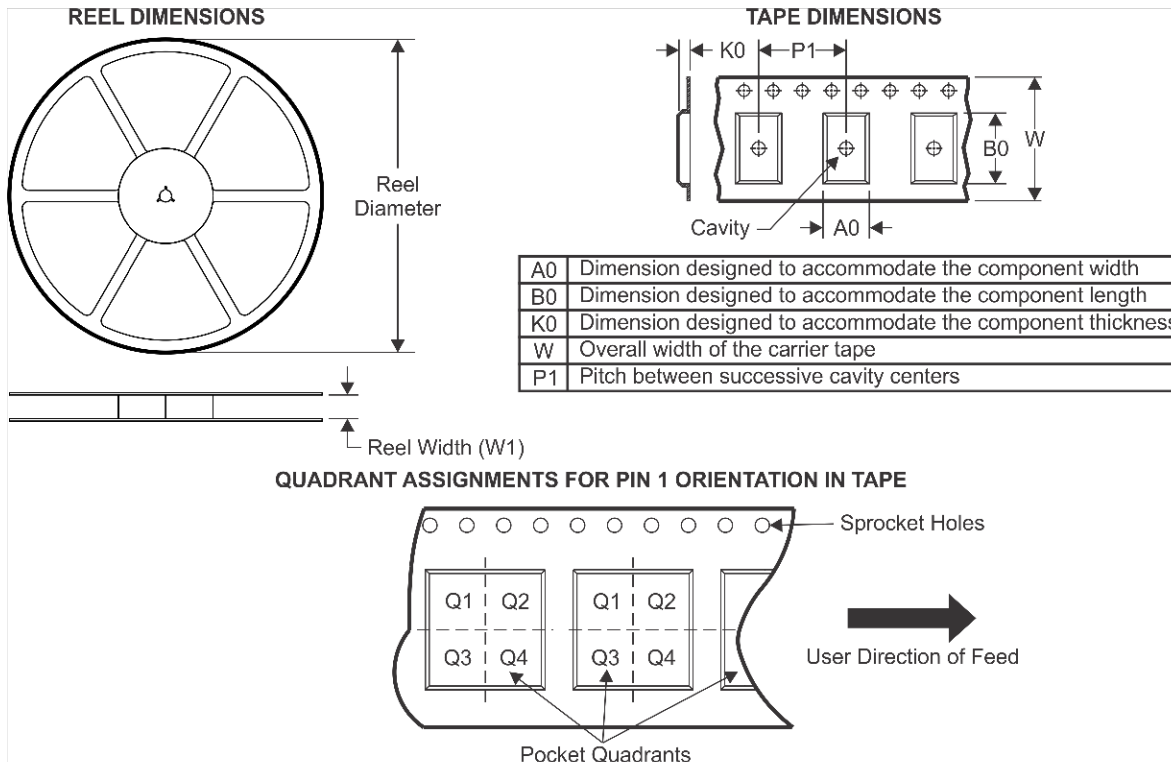

\*All dimensions are nominal

Device	Package Type	Package Drawing	Pins	SPQ	Reel Diameter (mm)	Reel Width W1 (mm)	A0 (mm)	B0 (mm)	K0 (mm)	P1 (mm)	W (mm)	Pin1 Quadrant
TLV5619CDWR	SOIC	DW	20	2000	330.0	24.4	10.8	13.3	2.7	12.0	24.0	Q1
TLV5619CPWR	TSSOP	PW	20	2000	330.0	16.4	6.95	7.1	1.6	8.0	16.0	Q1
TLV5619IDWR	SOIC	DW	20	2000	330.0	24.4	10.8	13.3	2.7	12.0	24.0	Q1
TLV5619IPWR	TSSOP	PW	20	2000	330.0	16.4	6.95	7.1	1.6	8.0	16.0	Q1

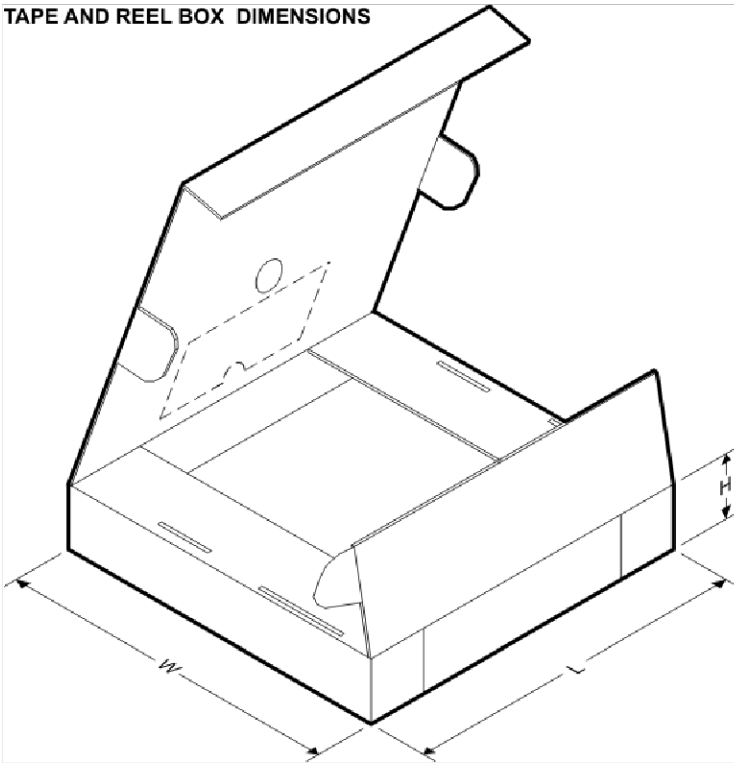
**TAPE AND REEL BOX DIMENSIONS**

\*All dimensions are nominal



Device	Package Type	Package Drawing	Pins	SPQ	Length (mm)	Width (mm)	Height (mm)
TLV5619CDWR	SOIC	DW	20	2000	350.0	350.0	43.0
TLV5619CPWR	TSSOP	PW	20	2000	350.0	350.0	43.0
TLV5619IDWR	SOIC	DW	20	2000	350.0	350.0	43.0
TLV5619IPWR	TSSOP	PW	20	2000	350.0	350.0	43.0

PW (R-PDSO-G20)

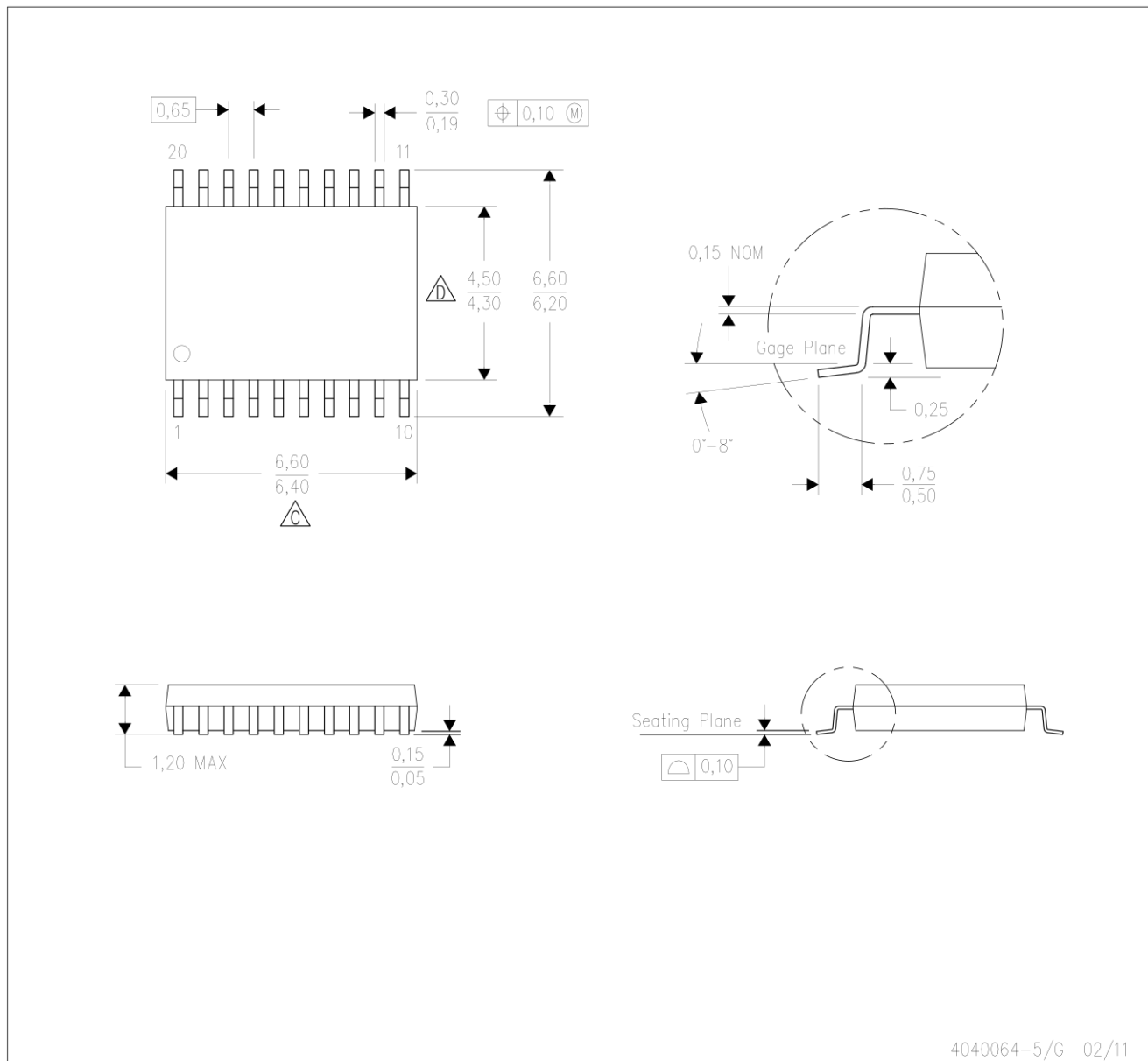
PLASTIC SMALL OUTLINE



4040064-5/G 02/11

- NOTES:
- A. All linear dimensions are in millimeters. Dimensioning and tolerancing per ASME Y14.5M-1994.
  - B. This drawing is subject to change without notice.
  -  C. Body length does not include mold flash, protrusions, or gate burrs. Mold flash, protrusions, or gate burrs shall not exceed 0,15 each side.
  -  D. Body width does not include interlead flash. Interlead flash shall not exceed 0,25 each side.
  - E. Falls within JEDEC MO-153

PW (R-PDSO-G20)

PLASTIC SMALL OUTLINE

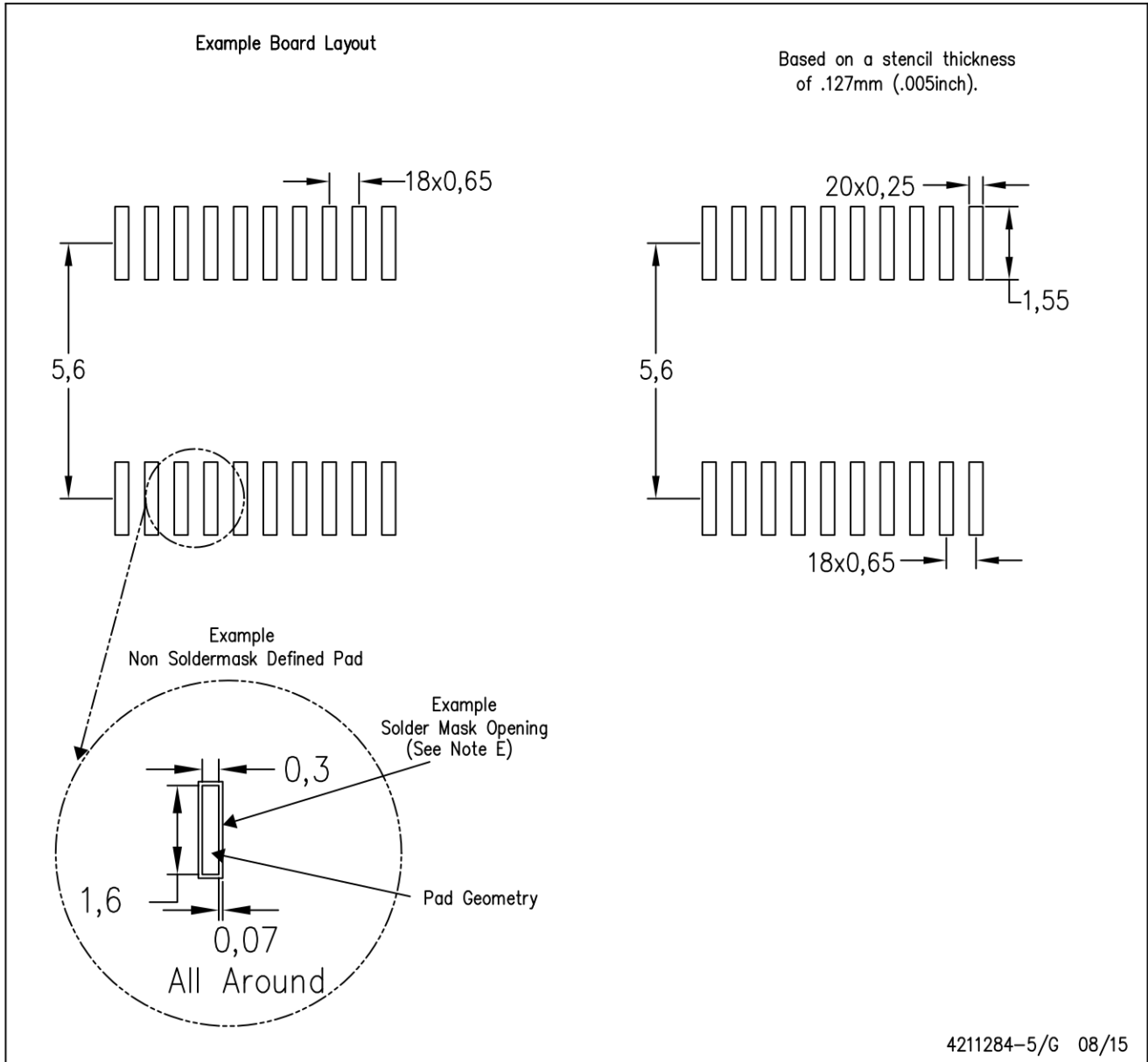

- NOTES:
- A. All linear dimensions are in millimeters.
  - B. This drawing is subject to change without notice.
  - C. Publication IPC-7351 is recommended for alternate design.
  - D. Laser cutting apertures with trapezoidal walls and also rounding corners will offer better paste release. Customers should contact their board assembly site for stencil design recommendations. Refer to IPC-7525 for other stencil recommendations.
  - E. Customers should contact their board fabrication site for solder mask tolerances between and around signal pads.

# DW0020A

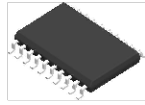

# PACKAGE OUTLINE

## SOIC - 2.65 mm max height

SOIC

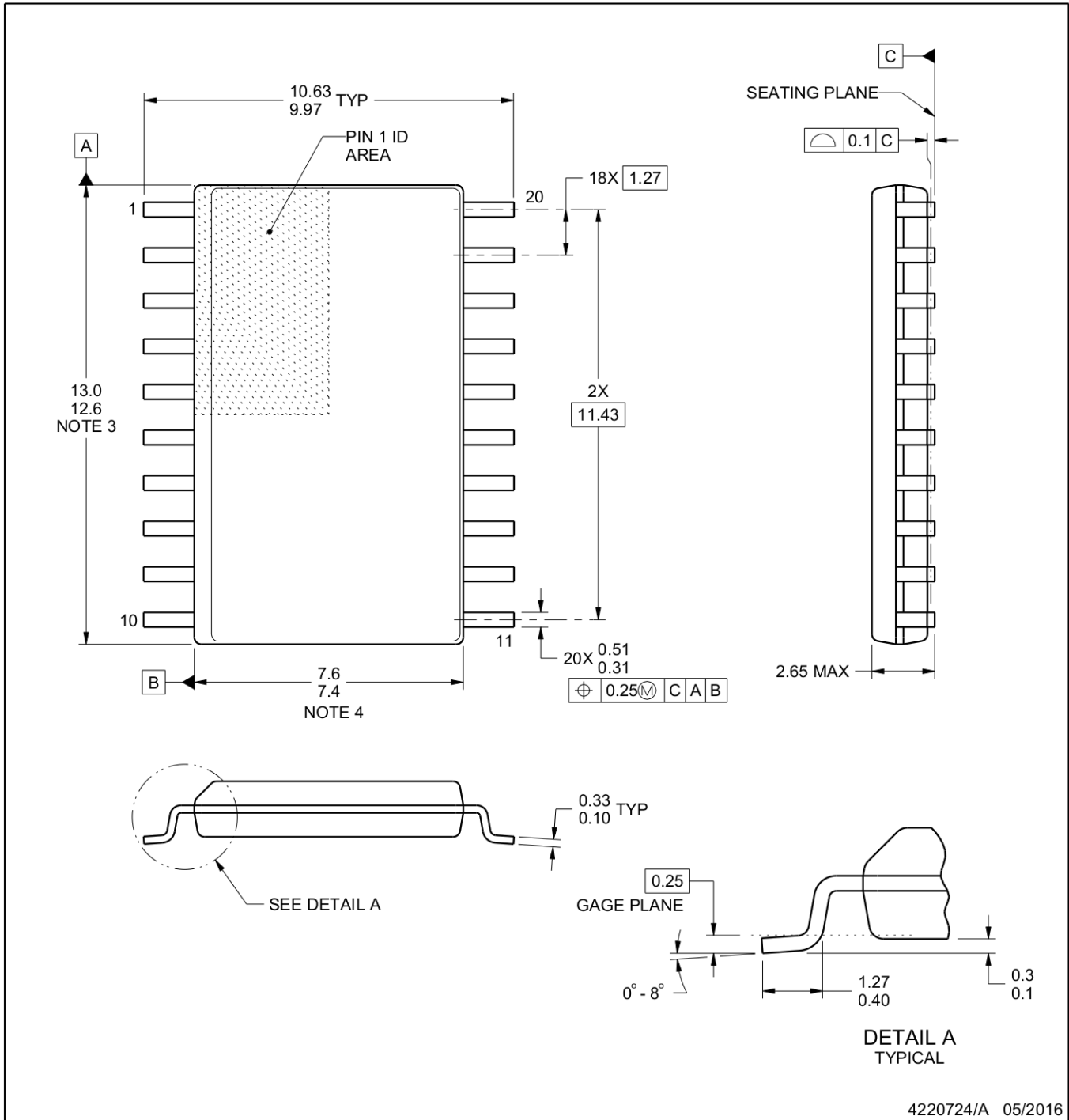

**NOTES:**

1. All linear dimensions are in millimeters. Dimensions in parenthesis are for reference only. Dimensioning and tolerancing per ASME Y14.5M.
2. This drawing is subject to change without notice.
3. This dimension does not include mold flash, protrusions, or gate burrs. Mold flash, protrusions, or gate burrs shall not exceed 0.15 mm per side.
4. This dimension does not include interlead flash. Interlead flash shall not exceed 0.43 mm per side.
5. Reference JEDEC registration MS-013.

# EXAMPLE BOARD LAYOUT

DW0020A

SOIC - 2.65 mm max height

SOIC

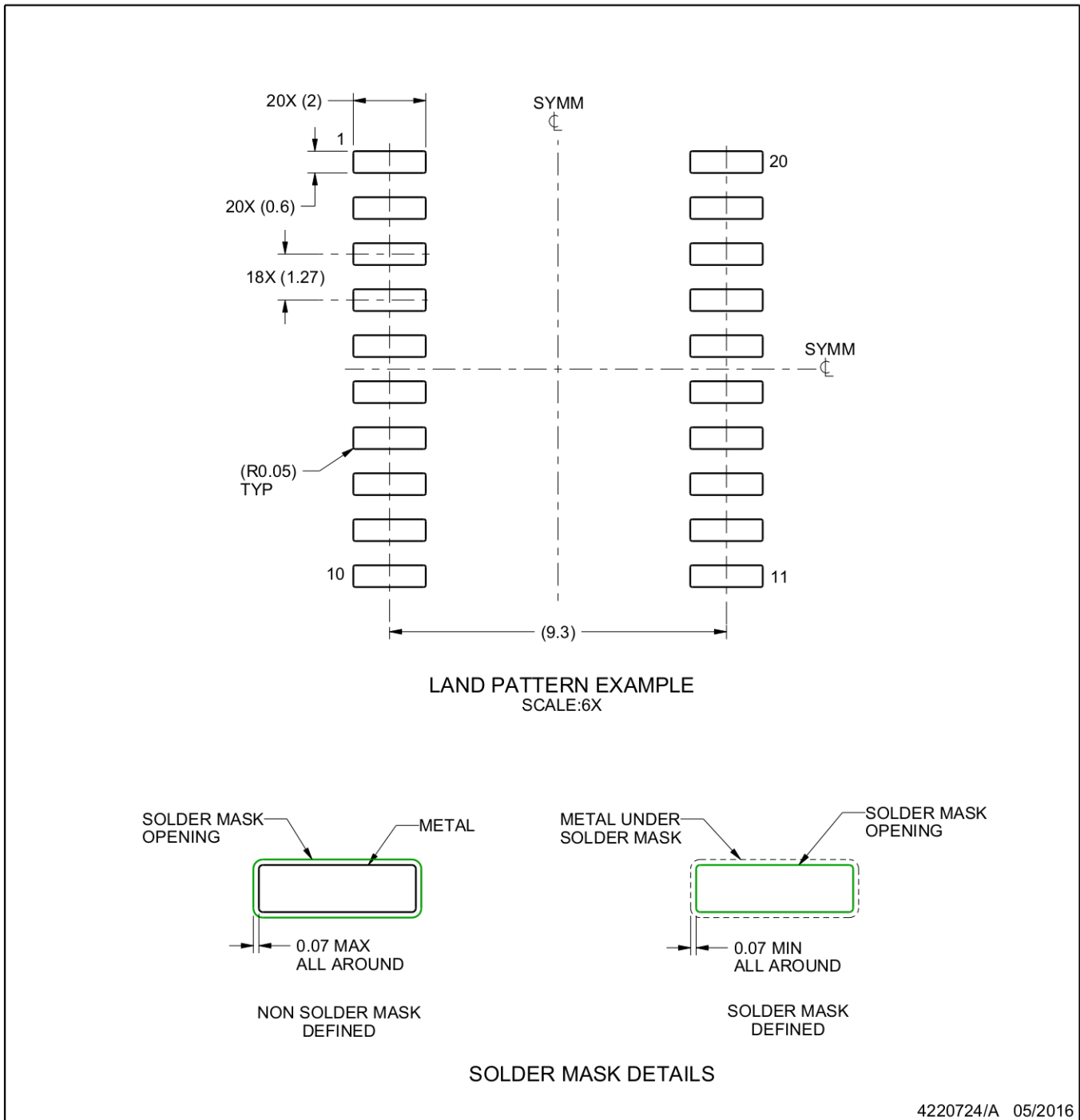

NOTES: (continued)

- 6. Publication IPC-7351 may have alternate designs.
- 7. Solder mask tolerances between and around signal pads can vary based on board fabrication site.

# EXAMPLE STENCIL DESIGN

DW0020A

SOIC - 2.65 mm max height

SOIC

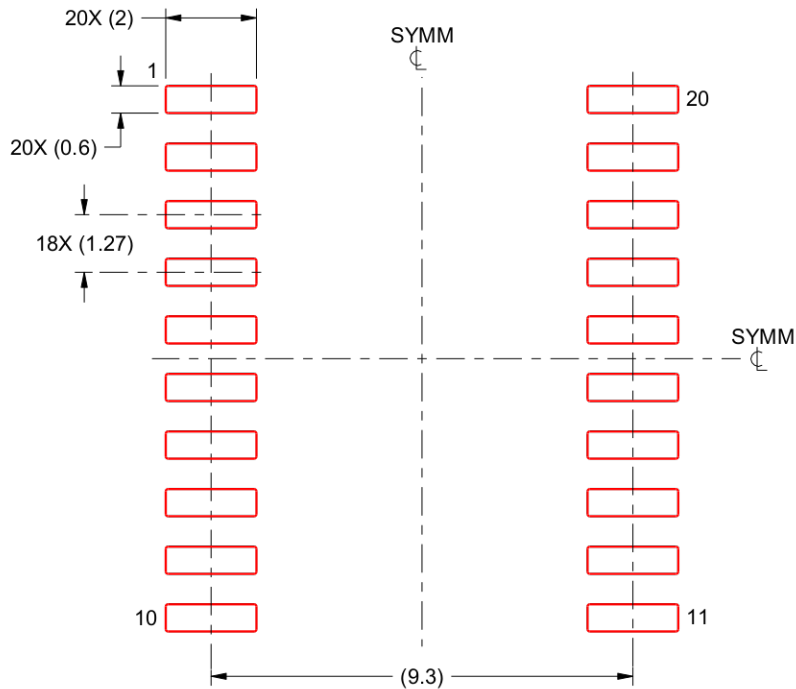

SOLDER PASTE EXAMPLE  
BASED ON 0.125 mm THICK STENCIL  
SCALE:6X

4220724/A 05/2016

NOTES: (continued)

8. Laser cutting apertures with trapezoidal walls and rounded corners may offer better paste release. IPC-7525 may have alternate design recommendations.
9. Board assembly site may have different recommendations for stencil design.



## IMPORTANT NOTICE AND DISCLAIMER

TI PROVIDES TECHNICAL AND RELIABILITY DATA (INCLUDING DATASHEETS), DESIGN RESOURCES (INCLUDING REFERENCE DESIGNS), APPLICATION OR OTHER DESIGN ADVICE, WEB TOOLS, SAFETY INFORMATION, AND OTHER RESOURCES "AS IS" AND WITH ALL FAULTS, AND DISCLAIMS ALL WARRANTIES, EXPRESS AND IMPLIED, INCLUDING WITHOUT LIMITATION ANY IMPLIED WARRANTIES OF MERCHANTABILITY, FITNESS FOR A PARTICULAR PURPOSE OR NON-INFRINGEMENT OF THIRD PARTY INTELLECTUAL PROPERTY RIGHTS.

These resources are intended for skilled developers designing with TI products. You are solely responsible for (1) selecting the appropriate TI products for your application, (2) designing, validating and testing your application, and (3) ensuring your application meets applicable standards, and any other safety, security, or other requirements. These resources are subject to change without notice. TI grants you permission to use these resources only for development of an application that uses the TI products described in the resource. Other reproduction and display of these resources is prohibited. No license is granted to any other TI intellectual property right or to any third party intellectual property right. TI disclaims responsibility for, and you will fully indemnify TI and its representatives against, any claims, damages, costs, losses, and liabilities arising out of your use of these resources.

TI's products are provided subject to TI's Terms of Sale ([www.ti.com/legal/termsofsale.html](http://www.ti.com/legal/termsofsale.html)) or other applicable terms available either on [ti.com](http://ti.com) or provided in conjunction with such TI products. TI's provision of these resources does not expand or otherwise alter TI's applicable warranties or warranty disclaimers for TI products.

Mailing Address: Texas Instruments, Post Office Box 655303, Dallas, Texas 75265  
Copyright © 2020, Texas Instruments Incorporated