

## CMOS Dual Monostable Multivibrator

High-Voltage Types (20-Volt Rating)

■ CD4098B dual monostable multivibrator provides stable retriggerable/resettable one-shot operation for any fixed-voltage timing application.

An external resistor ( $R_X$ ) and an external capacitor ( $C_X$ ) control the timing for the circuit. Adjustment of  $R_X$  and  $C_X$  provides a wide range of output pulse widths from the Q and  $\bar{Q}$  terminals. The time delay from trigger input to output transition (trigger propagation delay) and the time delay from reset input to output transition (reset propagation delay) are independent of  $R_X$  and  $C_X$ .

Leading-edge-triggering (+TR) and trailing-edge-triggering (-TR) inputs are provided for triggering from either edge of an input pulse. An unused +TR input should be tied to  $V_{SS}$ . An unused -TR input should be tied to  $V_{DD}$ . A RESET (on low level) is provided for immediate termination of the output pulse or to prevent output pulses when power is turned on. An unused RESET input should be tied to  $V_{DD}$ . However, if an entire section of the CD4098B is not used, its RESET should be tied to  $V_{SS}$ . See Table I.

In normal operation the circuit triggers (extends the output pulse one period) on the application of each new trigger pulse. For operation in the non-retriggerable mode,  $\bar{Q}$  is connected to -TR when leading-edge triggering (+TR) is used or Q is connected to +TR when trailing-edge triggering (-TR) is used.

The time period (T) for this multivibrator can be approximated by:  $T_X = \frac{1}{2} R_X C_X$  for  $C_X \geq 0.01 \mu F$ . Time periods as a function of  $R_X$  for values of  $C_X$  and  $V_{DD}$  are given in Fig. 8. Values of T vary from unit to unit and as a function of voltage, temperature, and  $R_X C_X$ .

The minimum value of external resistance,  $R_X$ , is 5 k $\Omega$ . The maximum value of external capacitance,  $C_X$ , is 100  $\mu F$ . Fig. 9 shows time periods as a function of  $C_X$  for values of  $R_X$  and  $V_{DD}$ .

The output pulse width has variations of  $\pm 2.5\%$  typically, over the temperature range of -55°C to 125°C for  $C_X = 1000$  pF and  $R_X = 100$  k $\Omega$ .

For power supply variations of  $\pm 5\%$ , the output pulse width has variations of  $\pm 0.5\%$  typically, for  $V_{DD} = 10$  V and 15 V and  $\pm 1\%$  typically, for  $V_{DD} = 5$  V at  $C_X = 1000$  pF and  $R_X = 5$  k $\Omega$ .

These types are supplied in 16-lead hermetic dual-in-line ceramic packages (F3A suffix), 16-lead dual-in-line plastic packages (E suffix), 16-lead small-outline packages (M, M96, and MT suffixes), and 16-lead thin shrink small-outline packages (PW and PWR suffixes).

The CD4098B is similar to type MC14528.

### Features:

- Retriggerable/resettable capability
- Trigger and reset propagation delays independent of  $R_X$ ,  $C_X$
- Triggering from leading or trailing edge
- Q and  $\bar{Q}$  buffered outputs available
- Separate resets
- Wide range of output-pulse widths
- 100% tested for maximum quiescent current at 20 V
- Maximum input current of 1  $\mu A$  at 18 V over full package-temperature range; 100 nA at 18 V and 25°C
- Noise margin (full package-temperature range):
  - 1 V at  $V_{DD} = 5$  V
  - 2 V at  $V_{DD} = 10$  V
  - 2.5 V at  $V_{DD} = 15$  V
- 5-V, 10-V, and 15-V parametric ratings
- Standardized, symmetrical output characteristics
- Meets all requirements of JEDEC Tentative Standard No. 13B, "Standard Specifications for Description of 'B' Series CMOS Devices."

### Applications:

- Pulse delay and timing
- Pulse shaping
- Astable multivibrator

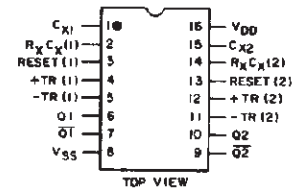
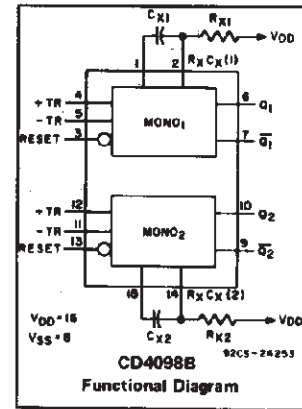

TERMINALS 1, 8, 15 ARE ELECTRICALLY CONNECTED INTERNALLY  
92CS-24846R1  
**TERMINAL ASSIGNMENT**

### MAXIMUM RATINGS, Absolute-Maximum Values:

DC SUPPLY-VOLTAGE RANGE, ( $V_{DD}$ )	Voltages referenced to $V_{SS}$ Terminal)		-0.5V to +20V
INPUT VOLTAGE RANGE, ALL INPUTS			-0.5V to $V_{DD} + 0.5V$
DC INPUT CURRENT, ANY ONE INPUT			$\pm 10$ mA
POWER DISSIPATION PER PACKAGE ( $P_D$ ):			
For $T_A = -55^\circ C$ to $+100^\circ C$			500 mW
For $T_A = +100^\circ C$ to $+125^\circ C$			Derate Linearly at 12 mW/ $^\circ C$ to 200 mW
DEVICE DISSIPATION PER OUTPUT TRANSISTOR			
For $T_A =$ FULL PACKAGE-TEMPERATURE RANGE (All Package Types)			100 mW
OPERATING-TEMPERATURE RANGE ( $T_A$ )			-55°C to +125°C
STORAGE TEMPERATURE RANGE ( $T_{stg}$ )			-85°C to +150°C
LEAD TEMPERATURE (DURING SOLDERING):			
At distance 1/16 $\pm$ 1/32 inch (1.59 $\pm$ 0.79 mm) from case for 10s max			+265°C

### RECOMMENDED OPERATING CONDITIONS

For maximum reliability, nominal operating conditions should be selected so that operation is always within the following ranges:

CHARACTERISTIC	$V_{DD}$ V	LIMITS		UNITS
		MIN.	MAX.	
Supply-Voltage Range (For $T_A =$ Full Package-Temperature Range)	-	3	18	V
Trigger Pulse Width $t_W$ (TR)	5 10 15	140 60 40	- - -	ns
Reset Pulse Width $t_W$ (R) (This is a function of $C_X$ )	-	See Dynamic Char. Chart and Fig. 10		-
Trigger Rise or Fall Time $t_r$ (TR), $t_f$ (TR)	5-15	-	100	$\mu s$

# CD4098B Types

**TABLE I**  
**CD4098B FUNCTIONAL TERMINAL CONNECTIONS**

FUNCTION	V <sub>DD</sub> TO TERM. NO.		V <sub>SS</sub> TO TERM. NO.		INPUT PULSE TO TERM. NO.		OTHER CONNECTIONS	
	MONO <sub>1</sub>	MONO <sub>2</sub>	MONO <sub>1</sub>	MONO <sub>2</sub>	MONO <sub>1</sub>	MONO <sub>2</sub>	MONO <sub>1</sub>	MONO <sub>2</sub>
Leading-Edge Trigger/Retriggerable	3, 5	11, 13			4	12		
Leading-Edge Trigger/Non-retriggerable	3	13			4	12	5-7	11-9
Trailing-Edge Trigger/Retriggerable	3	13	4	12	5	11		
Trailing-Edge Trigger/Non-retriggerable	3	13			5	11	4-6	12-10
Unused Section	5	11	3, 4	12, 13				

**NOTES:**

1. A RETRIGGERABLE ONE-SHOT MULTIVIBRATOR HAS AN OUTPUT PULSE WIDTH WHICH IS EXTENDED ONE FULL TIME PERIOD (T<sub>X</sub>) AFTER APPLICATION OF THE LAST TRIGGER PULSE.

The minimum time between retriggering edges (or trigger and retrigger edges) is 40 per cent of (T<sub>X</sub>).

2. A NON-RETRIGGERABLE ONE-SHOT MULTIVIBRATOR HAS A TIME PERIOD T<sub>X</sub> REFERENCED FROM THE APPLICATION OF THE FIRST TRIGGER PULSE.

INPUT PULSE TRAIN

RETRIGGERABLE MODE PULSE WIDTH (+TR MODE)

NON-RETRIGGERABLE MODE PULSE WIDTH (+TR MODE)

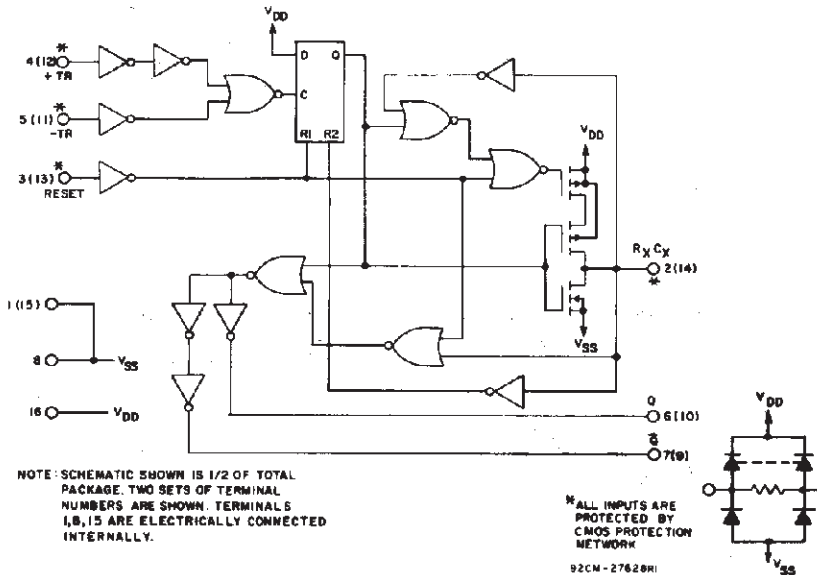
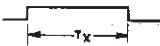

Fig. 4 - CD4098B logic diagram.

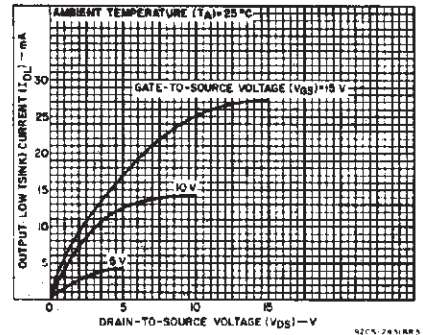

Fig. 1 - Typical output low (sink) current characteristics.

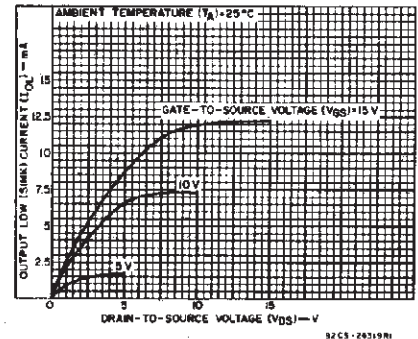

Fig. 2 - Minimum output low (sink) current characteristics.

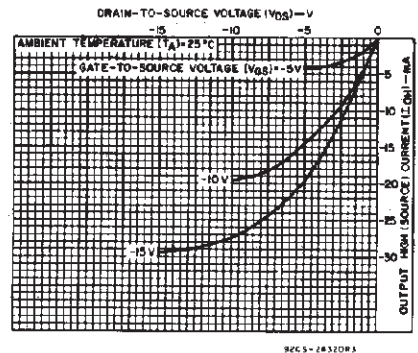

Fig. 3 - Typical output high (source) current characteristics.

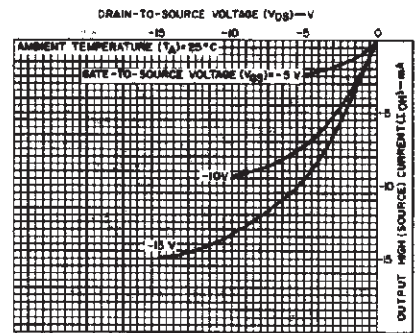

Fig. 5 - Minimum output high (source) current characteristics.

**3**  
**COMMERCIAL CMOS**  
**HIGH VOLTAGE ICs**

# CD4098B Types

## STATIC ELECTRICAL CHARACTERISTICS

CHARACTERISTIC	CONDITIONS			LIMITS AT INDICATED TEMPERATURES (°C)							UNITS	
	V <sub>O</sub> (V)	V <sub>IN</sub> (V)	V <sub>DD</sub> (V)	-55	-40	+85	+125	+25				
								Min.	Typ.	Max.		
Quiescent Device Current	—	0.5	5	1	1	30	30	—	0.02	1	μA	
I <sub>DD</sub> Max.	—	0.10	10	2	2	60	60	—	0.02	2		
	—	0.15	15	4	4	120	120	—	0.02	4		
Output Low (Sink) Current, I <sub>OL</sub> Min.	0.4	0.5	5	0.64	0.61	0.42	0.36	0.51	1	—	mA	
	0.5	0.10	10	1.6	1.5	1.1	0.9	1.3	2.6	—		
	1.5	0.15	15	4.2	4	2.8	2.4	3.4	6.8	—		
Output High (Source) Current, I <sub>OH</sub> Min.	4.6	0.5	5	-0.64	-0.61	-0.42	-0.36	-0.51	-1	—	mA	
	2.5	0.5	5	-2	-1.8	-1.3	-1.15	-1.6	-3.2	—		
	9.5	0.10	10	-1.6	-1.5	-1.1	-0.9	-1.3	-2.6	—		
Output Voltage: Low-Level, V <sub>OL</sub> Max.	—	0.5	5	0.05			—			0	0.05	V
	—	0.10	10	0.05			—			0	0.05	
	—	0.15	15	0.05			—			0	0.05	
Output Voltage: High-Level, V <sub>OH</sub> Min.	—	0.5	5	4.95			4.95			5	—	V
	—	0.10	10	9.95			9.95			10	—	
	—	0.15	15	14.95			14.95			15	—	
Input Low Voltage, V <sub>IL</sub> Max.	0.5, 4.5	—	5	1.5			—			—	1.5	V
	1.9	—	10	3			—			—	3	
	1.5, 13.5	—	15	4			—			—	4	
Input High Voltage, V <sub>IH</sub> Min.	0.5, 4.5	—	5	3.5			3.5			—	—	V
	1.9	—	10	7			7			—	—	
	1.5, 13.5	—	15	11			11			—	—	
Input Current, I <sub>IN</sub> Max.	—	0.18	18	±0.1	±0.1	±1	±1	—	±10 <sup>-5</sup>	±0.1	μA	

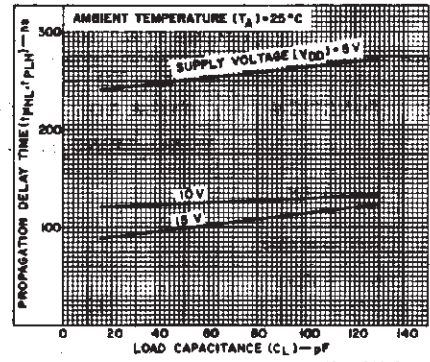

Fig. 6 - Typical propagation delay time vs. load capacitance, trigger into Q out. (All values of C<sub>X</sub> and R<sub>X</sub>.)

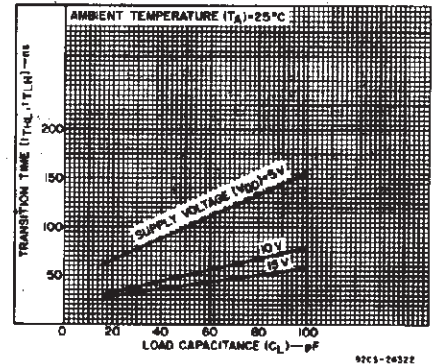

Fig. 7 - Transition time vs. load capacitance for R<sub>X</sub> = 5 kΩ-10000 kΩ and C<sub>X</sub> = 15 pF-10000 pF.

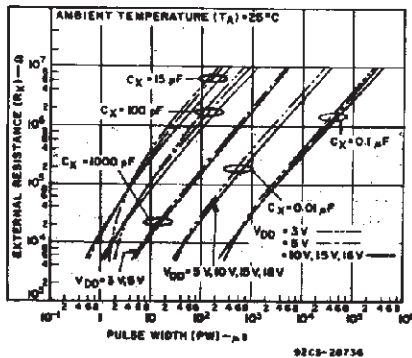

Fig. 8 - Typical external resistance vs. pulse width.

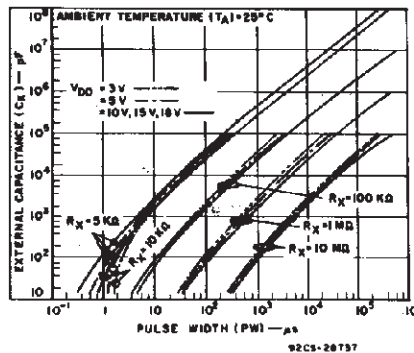

Fig. 9 - Typical external capacitance vs. pulse width.

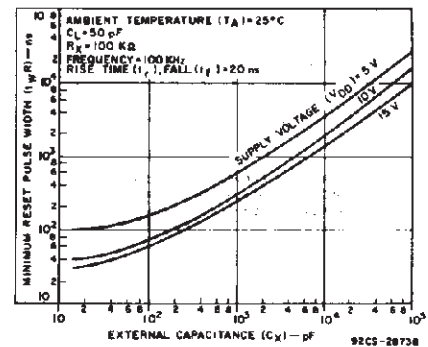

Fig. 10 - Typical minimum reset pulse width vs. external capacitance.

# CD4098B Types

## DYNAMIC ELECTRICAL CHARACTERISTICS

At  $T_A = 25^\circ\text{C}$ ; Input  $t_r, t_f = 20\text{ ns}$ ,  $C_L = 50\text{ pF}$ ,  $R_L = 200\text{ k}\Omega$

CHARACTERISTIC	TEST CONDITIONS			LIMITS		UNITS
	$R_X$ (k $\Omega$ )	$C_X$ (pF)	$V_{DD}$ (V)	Typ.	Max.	
Trigger Propagation Delay Time +TR, -TR to Q, $\bar{Q}$ $t_{PHL}$ , $t_{PLH}$	5 to 10,000	$\geq 15$	5 10 15	250 125 100	500 250 200	ns
Minimum Trigger Pulse Width, $t_{WH}$ , $t_{WL}$	5 to 10,000	$\geq 15$	5 10 15	70 30 20	140 60 40	ns
Transition Time, $t_{TLH}$	5 to 10,000	$\geq 15$	5 10 15	100 50 40	200 100 80	ns
$t_{THL}$	5 to 10,000	15 to 10,000	5 10 15	100 50 40	200 100 80	
	5 to 10,000	0.01 $\mu\text{F}$ to 0.1 $\mu\text{F}$	5 10 15	150 75 65	300 150 130	
	5 to 10,000	0.1 $\mu\text{F}$ to 1 $\mu\text{F}$	5 10 15	250 150 80	500 300 160	
Reset Propagation Delay Time, $T_{PHL}$ , $T_{PLH}$	5 to 10,000	$\geq 15$	5 10 15	225 125 75	450 250 150	ns
Minimum Reset Pulse Width, $t_{WR}$	100	15	5	100	200	ns
			10	40	80	
			15	30	60	
		0.1 $\mu\text{F}$	5	25	50	$\mu\text{s}$
Trigger Rise or Fall Time $t_r$ (TR), $t_f$ (TR)	—	—	5 to 15	—	100	$\mu\text{s}$
Pulse Width Match Between Circuits in Same Package	10	10,000	5 10 15	5 7.5 7.5	10 15 15	%
Input Capacitance, $C_{IN}$	Any Input			5	7.5	pF

## TEST CIRCUITS

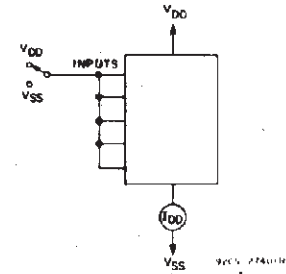

Fig. 12 - Quiescent-device-current test circuits.

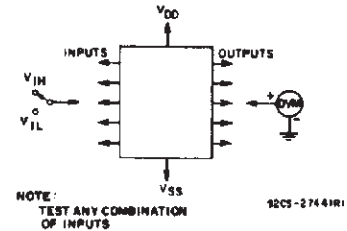

Fig. 13 - Input-voltage test circuit.

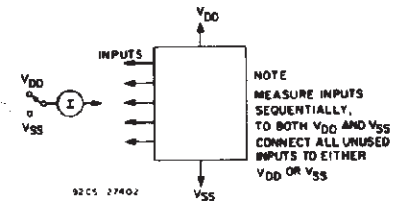

Fig. 14 - Input leakage current test circuit.

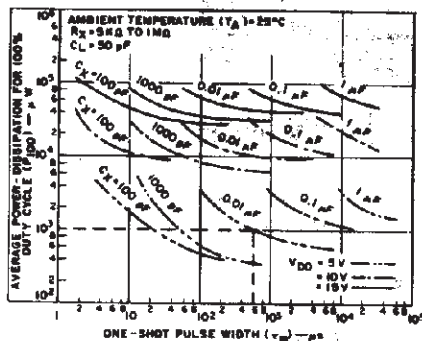
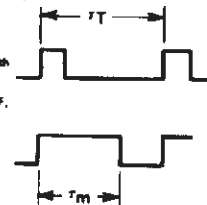

Fig. 11 - Average power dissipation vs. one-shot pulse width.

To calculate average power dissipation (P) for less than 100% duty cycle:  
 $P_{100}$  = average power for 100% duty cycle  
 $P = \left(\frac{t_m}{T}\right) P_{100}$  where  $t_m$  = one shot pulse width  
 $T$  = trigger pulse period  
 e.g. For  $t_m = 600\ \mu\text{s}$ ,  $T = 1000\ \mu\text{s}$ ,  $C_X = 0.01\ \mu\text{F}$ ,  
 $V_{DD} = 5\text{ V}$   
 $P = \left(\frac{600}{1000}\right) 110\ \mu\text{W} = 66\ \mu\text{W}$  (see dotted line on graph)



92CM-20730

3  
COMMERCIAL CMOS  
HIGH VOLTAGE ICs

# CD4098B Types

## APPLICATIONS

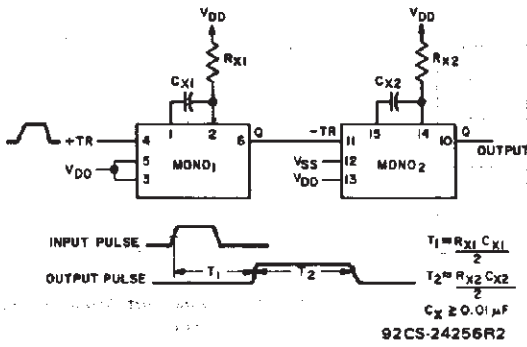

Fig. 15 - Pulse delay.

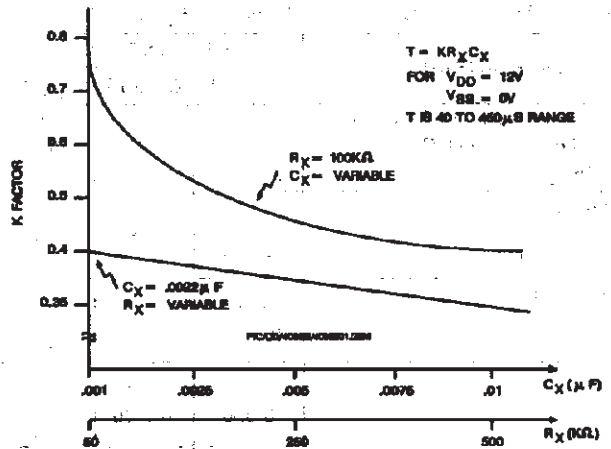

Fig. 17 - K-Factor for  $V_{DD} = 12V$ .

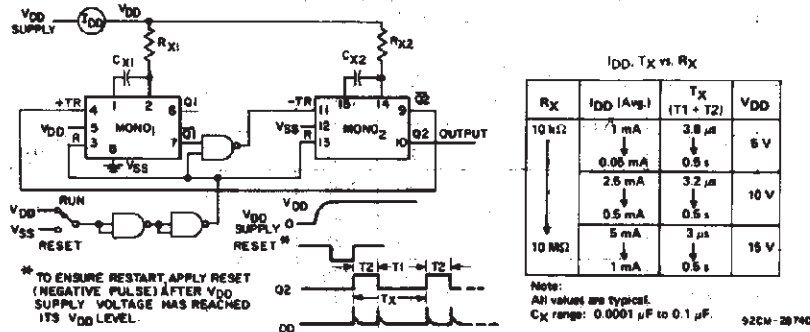
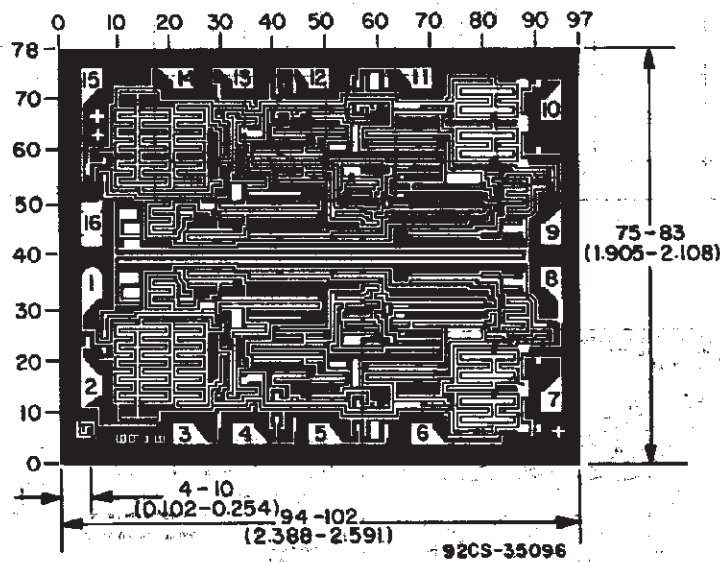

Fig. 16 - Astable multivibrator with restart after reset capability.



### Dimensions and Pad Layout for CD4098BH

Dimensions in parentheses are in millimeters and are derived from the basic inch dimensions as indicated. Grid graduations are in mils ( $10^{-3}$  inch).



**PACKAGING INFORMATION**

Orderable Device	Status (1)	Package Type	Package Drawing	Pins	Package Qty	Eco Plan (2)	Lead finish/ Ball material (6)	MSL Peak Temp (3)	Op Temp (°C)	Device Marking (4/5)	Samples
CD4098BE	ACTIVE	PDIP	N	16	25	RoHS & Green	NIPDAU	N / A for Pkg Type	-55 to 125	CD4098BE	<a href="#">Samples</a>
CD4098BEE4	ACTIVE	PDIP	N	16	25	RoHS & Green	NIPDAU	N / A for Pkg Type	-55 to 125	CD4098BE	<a href="#">Samples</a>
CD4098BF	ACTIVE	CDIP	J	16	1	Non-RoHS & Non-Green	SNPB	N / A for Pkg Type	-55 to 125	CD4098BF	<a href="#">Samples</a>
CD4098BF3A	ACTIVE	CDIP	J	16	1	Non-RoHS & Non-Green	SNPB	N / A for Pkg Type	-55 to 125	CD4098BF3A	<a href="#">Samples</a>
CD4098BM	ACTIVE	SOIC	D	16	40	RoHS & Green	NIPDAU	Level-1-260C-UNLIM	-55 to 125	CD4098BM	<a href="#">Samples</a>
CD4098BM96	ACTIVE	SOIC	D	16	2500	RoHS & Green	NIPDAU	Level-1-260C-UNLIM	-55 to 125	CD4098BM	<a href="#">Samples</a>
CD4098BM96G4	ACTIVE	SOIC	D	16	2500	RoHS & Green	NIPDAU	Level-1-260C-UNLIM	-55 to 125	CD4098BM	<a href="#">Samples</a>
CD4098BMT	ACTIVE	SOIC	D	16	250	RoHS & Green	NIPDAU	Level-1-260C-UNLIM	-55 to 125	CD4098BM	<a href="#">Samples</a>
CD4098BPW	ACTIVE	TSSOP	PW	16	90	RoHS & Green	NIPDAU	Level-1-260C-UNLIM	-55 to 125	CM098B	<a href="#">Samples</a>
CD4098BPWR	ACTIVE	TSSOP	PW	16	2000	RoHS & Green	NIPDAU	Level-1-260C-UNLIM	-55 to 125	CM098B	<a href="#">Samples</a>
JM38510/17504BEA	ACTIVE	CDIP	J	16	1	Non-RoHS & Non-Green	SNPB	N / A for Pkg Type	-55 to 125	JM38510/ 17504BEA	<a href="#">Samples</a>
M38510/17504BEA	ACTIVE	CDIP	J	16	1	Non-RoHS & Non-Green	SNPB	N / A for Pkg Type	-55 to 125	JM38510/ 17504BEA	<a href="#">Samples</a>

(1) The marketing status values are defined as follows:

**ACTIVE:** Product device recommended for new designs.

**LIFEBUY:** TI has announced that the device will be discontinued, and a lifetime-buy period is in effect.

**NRND:** Not recommended for new designs. Device is in production to support existing customers, but TI does not recommend using this part in a new design.

**PREVIEW:** Device has been announced but is not in production. Samples may or may not be available.

**OBSOLETE:** TI has discontinued the production of the device.

(2) **RoHS:** TI defines "RoHS" to mean semiconductor products that are compliant with the current EU RoHS requirements for all 10 RoHS substances, including the requirement that RoHS substance do not exceed 0.1% by weight in homogeneous materials. Where designed to be soldered at high temperatures, "RoHS" products are suitable for use in specified lead-free processes. TI may reference these types of products as "Pb-Free".

**RoHS Exempt:** TI defines "RoHS Exempt" to mean products that contain lead but are compliant with EU RoHS pursuant to a specific EU RoHS exemption.

**Green:** TI defines "Green" to mean the content of Chlorine (Cl) and Bromine (Br) based flame retardants meet JS709B low halogen requirements of <=1000ppm threshold. Antimony trioxide based flame retardants must also meet the <=1000ppm threshold requirement.

- (3) MSL, Peak Temp. - The Moisture Sensitivity Level rating according to the JEDEC industry standard classifications, and peak solder temperature.
- (4) There may be additional marking, which relates to the logo, the lot trace code information, or the environmental category on the device.
- (5) Multiple Device Markings will be inside parentheses. Only one Device Marking contained in parentheses and separated by a "~" will appear on a device. If a line is indented then it is a continuation of the previous line and the two combined represent the entire Device Marking for that device.
- (6) Lead finish/Ball material - Orderable Devices may have multiple material finish options. Finish options are separated by a vertical ruled line. Lead finish/Ball material values may wrap to two lines if the finish value exceeds the maximum column width.

**Important Information and Disclaimer:**The information provided on this page represents TI's knowledge and belief as of the date that it is provided. TI bases its knowledge and belief on information provided by third parties, and makes no representation or warranty as to the accuracy of such information. Efforts are underway to better integrate information from third parties. TI has taken and continues to take reasonable steps to provide representative and accurate information but may not have conducted destructive testing or chemical analysis on incoming materials and chemicals. TI and TI suppliers consider certain information to be proprietary, and thus CAS numbers and other limited information may not be available for release.

In no event shall TI's liability arising out of such information exceed the total purchase price of the TI part(s) at issue in this document sold by TI to Customer on an annual basis.

**OTHER QUALIFIED VERSIONS OF CD4098B, CD4098B-MIL :**

- Catalog: [CD4098B](#)
- Military: [CD4098B-MIL](#)

NOTE: Qualified Version Definitions:

- Catalog - TI's standard catalog product
- Military - QML certified for Military and Defense Applications

## TAPE AND REEL INFORMATION

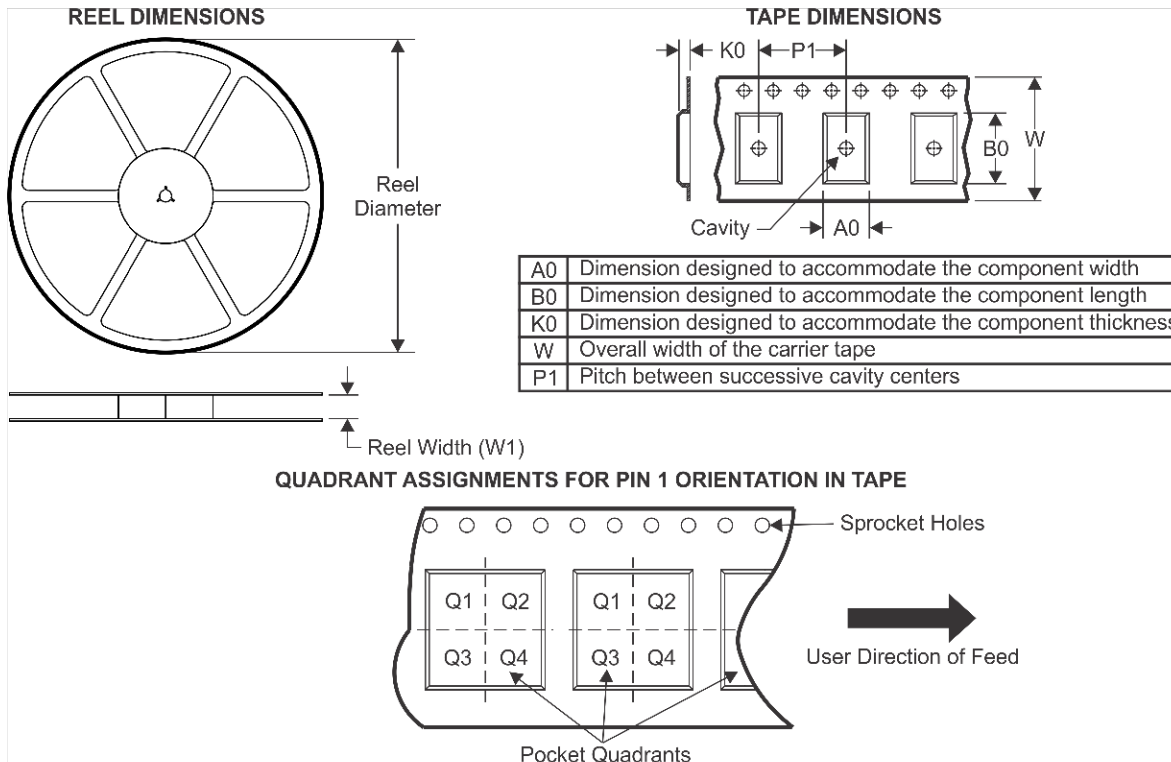

\*All dimensions are nominal

Device	Package Type	Package Drawing	Pins	SPQ	Reel Diameter (mm)	Reel Width W1 (mm)	A0 (mm)	B0 (mm)	K0 (mm)	P1 (mm)	W (mm)	Pin1 Quadrant
CD4098BM96	SOIC	D	16	2500	330.0	16.4	6.5	10.3	2.1	8.0	16.0	Q1
CD4098BPWR	TSSOP	PW	16	2000	330.0	12.4	6.9	5.6	1.6	8.0	12.0	Q1

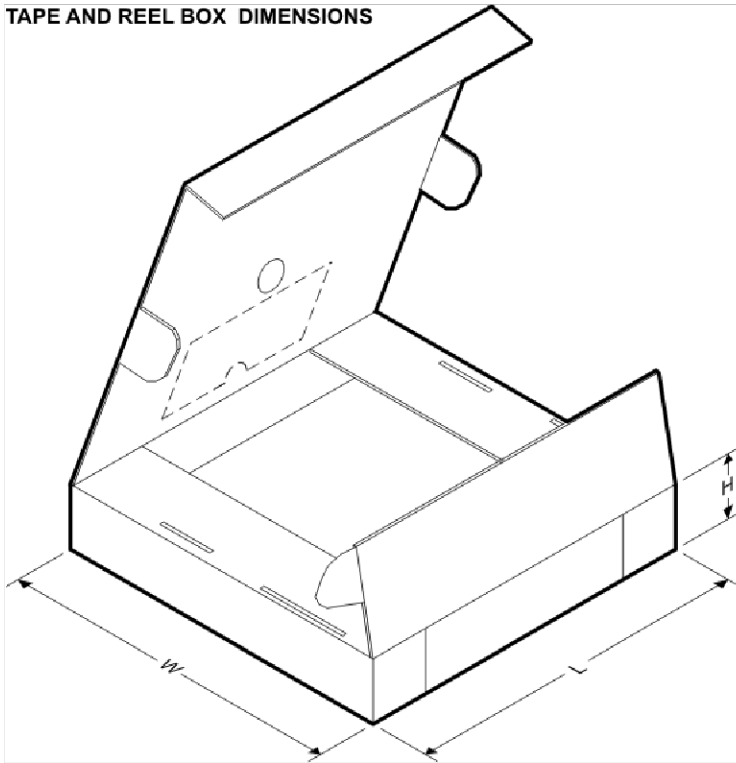

**TAPE AND REEL BOX DIMENSIONS**

\*All dimensions are nominal

Device	Package Type	Package Drawing	Pins	SPQ	Length (mm)	Width (mm)	Height (mm)
CD4098BM96	SOIC	D	16	2500	333.2	345.9	28.6
CD4098BPWR	TSSOP	PW	16	2000	853.0	449.0	35.0

J (R-GDIP-T\*\*)  
14 LEADS SHOWN

CERAMIC DUAL IN-LINE PACKAGE

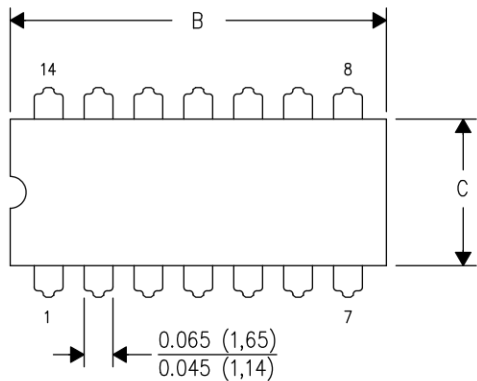

DIM \ PINS **	14	16	18	20
A	0.300 (7,62) BSC	0.300 (7,62) BSC	0.300 (7,62) BSC	0.300 (7,62) BSC
B MAX	0.785 (19,94)	.840 (21,34)	0.960 (24,38)	1.060 (26,92)
B MIN	—	—	—	—
C MAX	0.300 (7,62)	0.300 (7,62)	0.310 (7,87)	0.300 (7,62)
C MIN	0.245 (6,22)	0.245 (6,22)	0.220 (5,59)	0.245 (6,22)

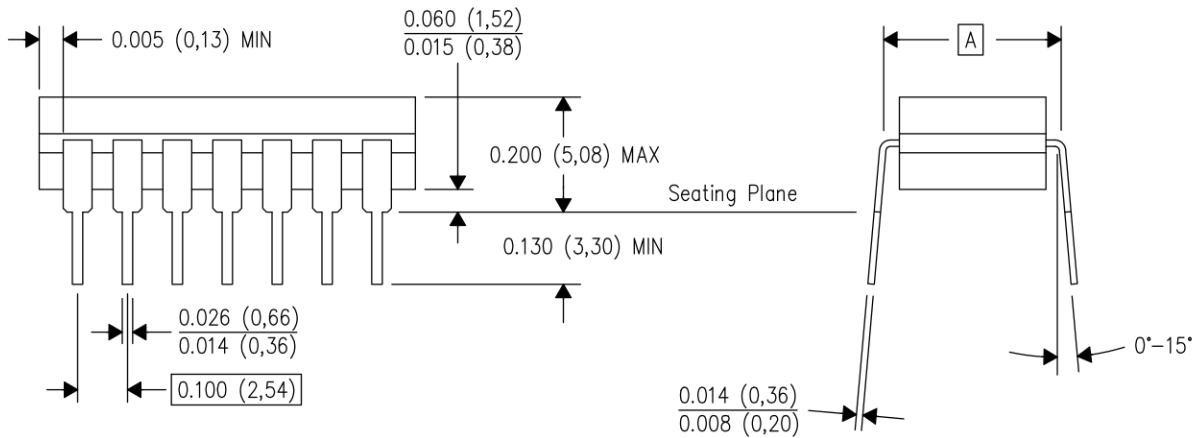

4040083/F 03/03

- NOTES:
- All linear dimensions are in inches (millimeters).
  - This drawing is subject to change without notice.
  - This package is hermetically sealed with a ceramic lid using glass frit.
  - Index point is provided on cap for terminal identification only on press ceramic glass frit seal only.
  - Falls within MIL STD 1835 GDIP1-T14, GDIP1-T16, GDIP1-T18 and GDIP1-T20.

N (R-PDIP-T\*\*)

PLASTIC DUAL-IN-LINE PACKAGE

16 PINS SHOWN

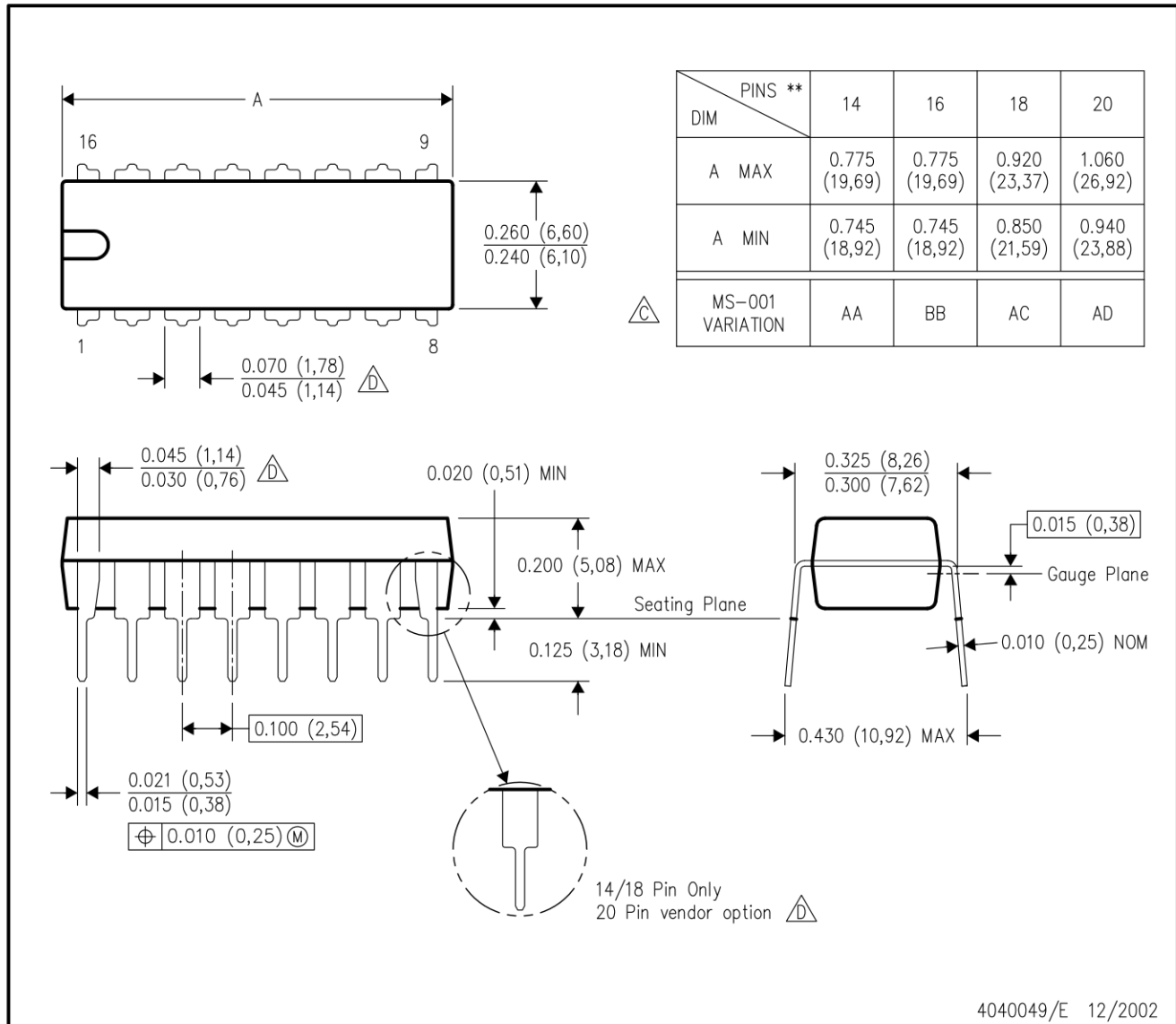

- NOTES:
- A. All linear dimensions are in inches (millimeters).
  - B. This drawing is subject to change without notice.
  - $\triangle C$  Falls within JEDEC MS-001, except 18 and 20 pin minimum body length (Dim A).
  - $\triangle D$  The 20 pin end lead shoulder width is a vendor option, either half or full width.

4040049/E 12/2002

D (R-PDSO-G16)

PLASTIC SMALL OUTLINE

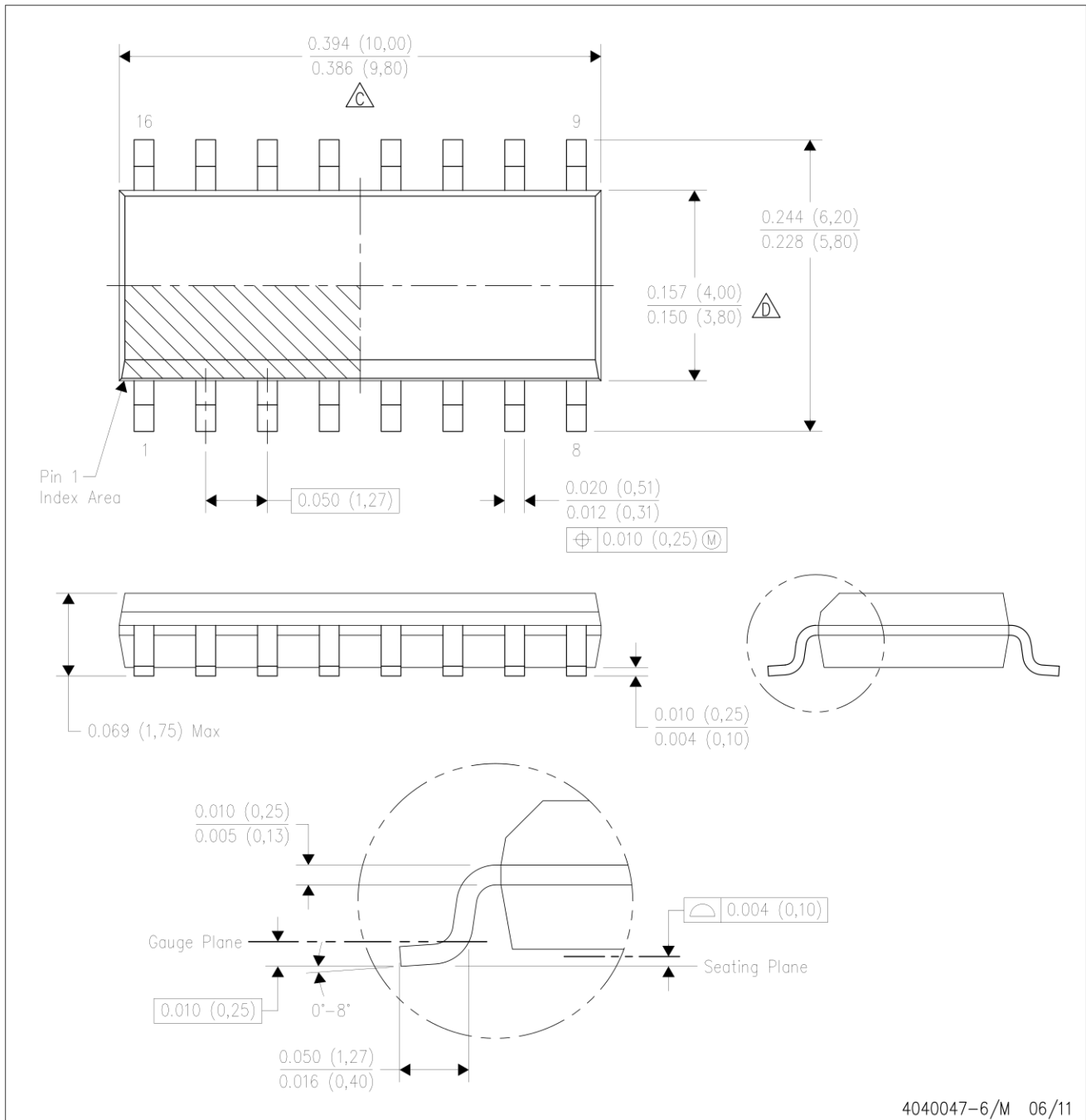

- NOTES:
- A. All linear dimensions are in inches (millimeters).
  - B. This drawing is subject to change without notice.
  - C. Body length does not include mold flash, protrusions, or gate burrs. Mold flash, protrusions, or gate burrs shall not exceed 0.006 (0,15) each side.
  - D. Body width does not include interlead flash. Interlead flash shall not exceed 0.017 (0,43) each side.
  - E. Reference JEDEC MS-012 variation AC.

D (R-PDSO-G16)

PLASTIC SMALL OUTLINE

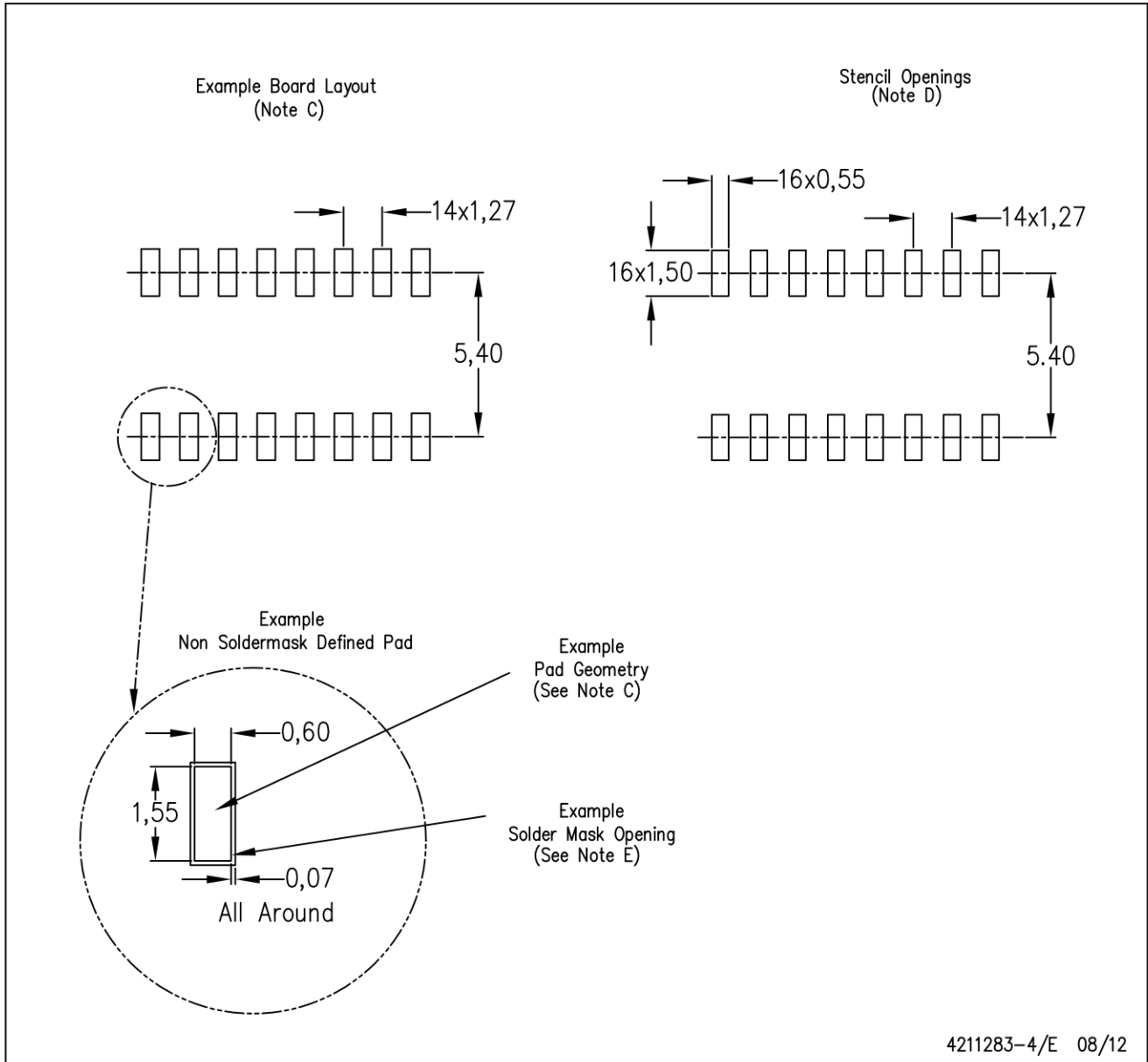

4211283-4/E 08/12

- NOTES:
- All linear dimensions are in millimeters.
  - This drawing is subject to change without notice.
  - Publication IPC-7351 is recommended for alternate designs.
  - Laser cutting apertures with trapezoidal walls and also rounding corners will offer better paste release. Customers should contact their board assembly site for stencil design recommendations. Refer to IPC-7525 for other stencil recommendations.
  - Customers should contact their board fabrication site for solder mask tolerances between and around signal pads.

# PW0016A

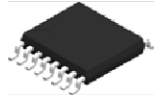

# PACKAGE OUTLINE

## TSSOP - 1.2 mm max height

SMALL OUTLINE PACKAGE

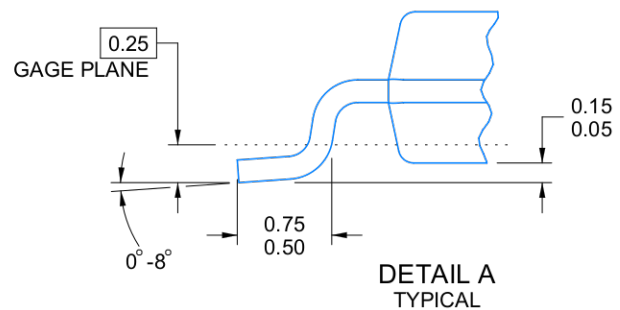
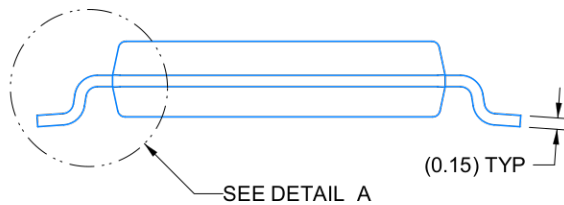
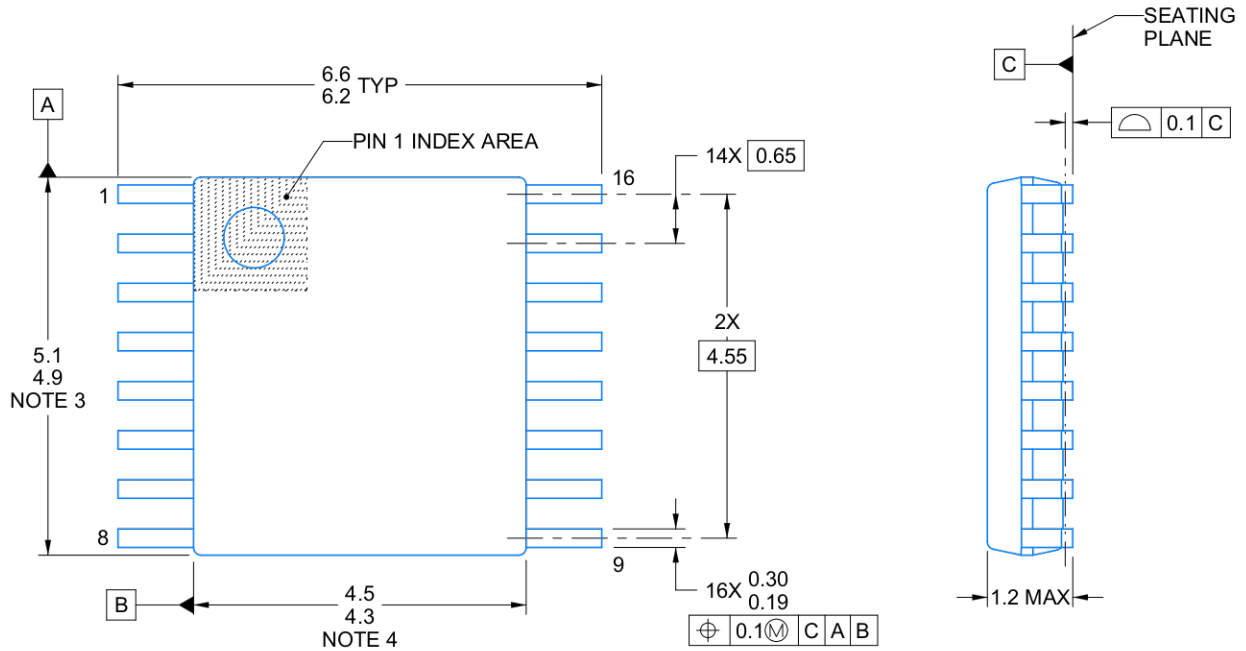

4220204/A 02/2017

### NOTES:

1. All linear dimensions are in millimeters. Any dimensions in parenthesis are for reference only. Dimensioning and tolerancing per ASME Y14.5M.
2. This drawing is subject to change without notice.
3. This dimension does not include mold flash, protrusions, or gate burrs. Mold flash, protrusions, or gate burrs shall not exceed 0.15 mm per side.
4. This dimension does not include interlead flash. Interlead flash shall not exceed 0.25 mm per side.
5. Reference JEDEC registration MO-153.



# EXAMPLE BOARD LAYOUT

PW0016A

TSSOP - 1.2 mm max height

SMALL OUTLINE PACKAGE

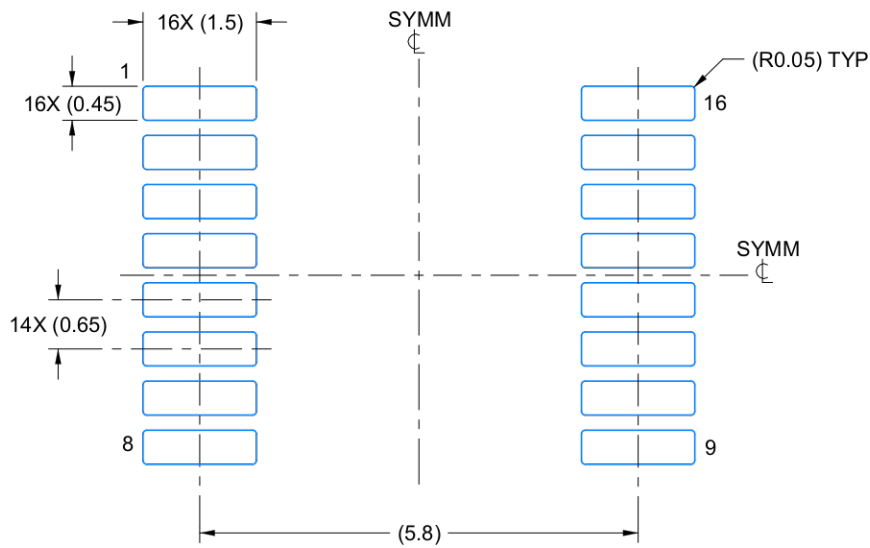

LAND PATTERN EXAMPLE  
EXPOSED METAL SHOWN  
SCALE: 10X

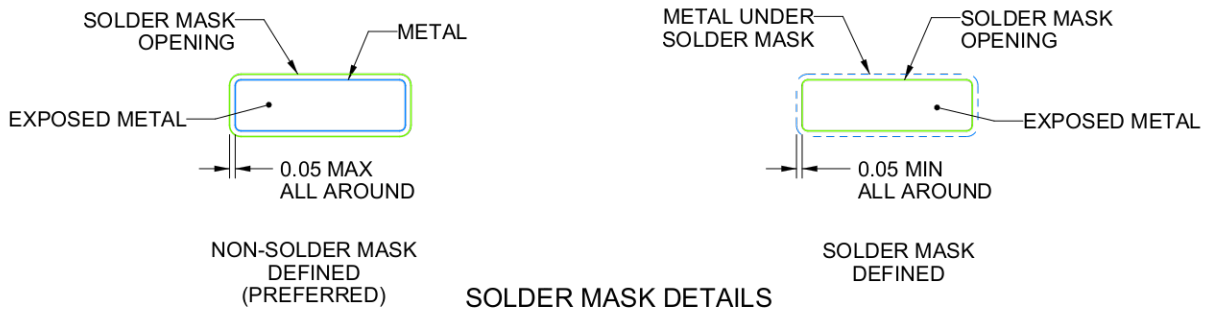

SOLDER MASK DETAILS

4220204/A 02/2017

NOTES: (continued)

- 6. Publication IPC-7351 may have alternate designs.
- 7. Solder mask tolerances between and around signal pads can vary based on board fabrication site.

# EXAMPLE STENCIL DESIGN

PW0016A

TSSOP - 1.2 mm max height

SMALL OUTLINE PACKAGE

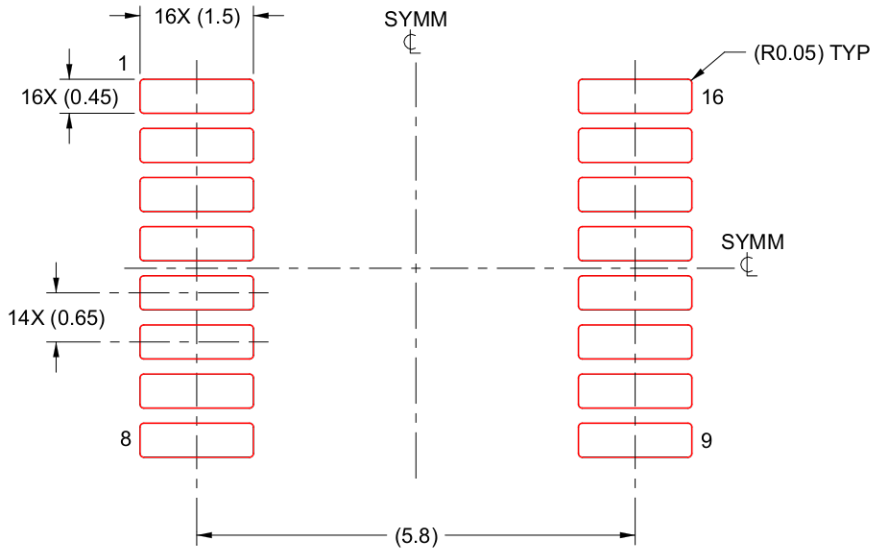

SOLDER PASTE EXAMPLE  
BASED ON 0.125 mm THICK STENCIL  
SCALE: 10X

4220204/A 02/2017

NOTES: (continued)

8. Laser cutting apertures with trapezoidal walls and rounded corners may offer better paste release. IPC-7525 may have alternate design recommendations.
9. Board assembly site may have different recommendations for stencil design.

## IMPORTANT NOTICE AND DISCLAIMER

TI PROVIDES TECHNICAL AND RELIABILITY DATA (INCLUDING DATASHEETS), DESIGN RESOURCES (INCLUDING REFERENCE DESIGNS), APPLICATION OR OTHER DESIGN ADVICE, WEB TOOLS, SAFETY INFORMATION, AND OTHER RESOURCES "AS IS" AND WITH ALL FAULTS, AND DISCLAIMS ALL WARRANTIES, EXPRESS AND IMPLIED, INCLUDING WITHOUT LIMITATION ANY IMPLIED WARRANTIES OF MERCHANTABILITY, FITNESS FOR A PARTICULAR PURPOSE OR NON-INFRINGEMENT OF THIRD PARTY INTELLECTUAL PROPERTY RIGHTS.

These resources are intended for skilled developers designing with TI products. You are solely responsible for (1) selecting the appropriate TI products for your application, (2) designing, validating and testing your application, and (3) ensuring your application meets applicable standards, and any other safety, security, or other requirements. These resources are subject to change without notice. TI grants you permission to use these resources only for development of an application that uses the TI products described in the resource. Other reproduction and display of these resources is prohibited. No license is granted to any other TI intellectual property right or to any third party intellectual property right. TI disclaims responsibility for, and you will fully indemnify TI and its representatives against, any claims, damages, costs, losses, and liabilities arising out of your use of these resources.

TI's products are provided subject to TI's Terms of Sale ([www.ti.com/legal/termsofsale.html](http://www.ti.com/legal/termsofsale.html)) or other applicable terms available either on [ti.com](http://ti.com) or provided in conjunction with such TI products. TI's provision of these resources does not expand or otherwise alter TI's applicable warranties or warranty disclaimers for TI products.

Mailing Address: Texas Instruments, Post Office Box 655303, Dallas, Texas 75265  
Copyright © 2020, Texas Instruments Incorporated