

CMOS BCD-to-7-Segment Latch Decoder Drivers

High-Voltage Types (20-Volt Rating)



CD4511B types are BCD-to-7-segment latch decoder drivers constructed with CMOS logic and n-p-n bipolar transistor output devices on a single monolithic structure. These devices combine the low quiescent power dissipation and high noise immunity features of RCA CMOS with n-p-n bipolar output transistors capable of sourcing up to 25 mA. This capability allows the CD4511B types to drive LED's and other displays directly.

Lamp Test (LT), Blanking (BL), and Latch Enable or Strobe inputs are provided to test the display, shut off or intensity-modulate it, and store or strobe a BCD code, respectively. Several different signals may be multiplexed and displayed when external multiplexing circuitry is used.

The CD4511B types are supplied in 16-lead hermetic dual-in-line ceramic packages (F3A suffix), 16-lead dual-in-line plastic packages (E suffix), 16-lead small-outline packages (NSR suffix), and 16-lead thin shrink small-outline packages (PW and PWR suffixes).

These devices are similar to the type MC14511.

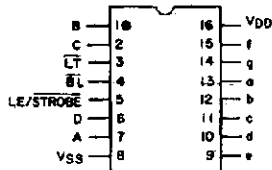

TOP VIEW
92CS-25084B
CD4511B
TERMINAL ASSIGNMENT

Features:

- High-output-sourcing capability up to 25 mA
- input latches for BCD Code storage
- Lamp Test and Blanking capability
- 7-segment outputs blanked for BCD input codes > 1001
- 100% tested for quiescent current at 20 V
- Max. input current of 1 μ A at 18 V, over full package-temperature range, 100 nA at 18 V and 25°C
- 5-V, 10-V, and 15-V parametric ratings

Applications:

- Driving common-cathode LED displays
- Multiplexing with common-cathode LED displays
- Driving incandescent displays
- Driving low-voltage fluorescent displays

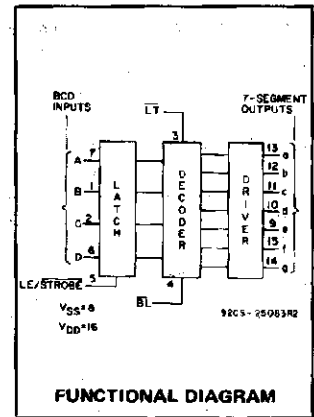

MAXIMUM RATINGS, Absolute-Maximum Values:

DC SUPPLY-VOLTAGE RANGE, (V _{DD})	Voltages referenced to V _{SS} Terminal		-0.5V to +20V
INPUT VOLTAGE RANGE, ALL INPUTS			-0.5V to V _{DD} +0.5V
DC INPUT CURRENT, ANY ONE INPUT			±10mA
POWER DISSIPATION, PER PACKAGE (P _D):			
For T _A = -55°C to +100°C			500mW
For T _A = +100°C to +125°C	Derate Linearly at 12mW/°C		to 200mW
DEVICE DISSIPATION PER OUTPUT TRANSISTOR			
FOR T _A = FULL PACKAGE-TEMPERATURE RANGE (All Package Types)			100mW
OPERATING-TEMPERATURE RANGE (T _A)			-55°C to +125°C
STORAGE TEMPERATURE RANGE (T _{stg})			-65°C to +150°C
LEAD TEMPERATURE (DURING SOLDERING):			
At distance 1/16 ± 1/32 Inch (1.58 ± 0.79mm) from case for 10s max			+265°C

OPERATING CONDITIONS AT T_A = 25°C Unless Otherwise Specified

For maximum reliability, nominal operating conditions should be selected so that operation is always within the following ranges

Characteristic	V _{DD}	Min.	Max.	Units
Supply Voltage Range (T _A): (Full Package-Temperature Range)	-	3	18	V
Set-Up Time (t _S)	5	150	-	ns
	10	70	-	ns
	15	40	-	ns
Hold Time (t _H)	5	0	-	ns
	10	0	-	ns
	15	0	-	ns
Strobe Pulse Width (t _W)	5	400	-	ns
	10	160	-	ns
	15	100	-	ns

3
COMMERCIAL CMOS
HIGH VOLTAGE ICs

CD4511B Types

STATIC ELECTRICAL CHARACTERISTICS

CHARACTERISTIC	TEST CONDITIONS				LIMITS AT INDICATED TEMPERATURES (°C)							Units
	I _{OH} (mA)	V _O (V)	V _{IN} (V)	V _{DD} (V)	-55	-40	+85	+125	+25			
									Min.	Typ.	Max.	
Quiescent Device Current: I _{DD} Max.	-	-	-	5	5	5	150	150	-	0.04	5	μA
	-	-	-	10	10	10	300	300	-	0.04	10	
	-	-	-	15	20	20	600	600	-	0.04	20	
	-	-	-	20	100	100	3000	3000	-	0.08	100	
Output Voltage: Low-Level V _{OL} Max.	-	-	0.5	5	0.05				-	0	0.05	V
	-	-	0.10	10	0.05				-	0	0.05	
High-Level V _{OH} Min.	-	-	0.5	5	4	4	4.2	4.2	4.1	4.55	-	V
	-	-	0.10	10	9	9	9.2	9.2	9.1	9.55	-	
Input Low Voltage, V _{IL} Max.	-	0.5, 3.8	-	5	1.5				-	-	1.5	V
	-	1.8, 8	-	10	3				-	-	3	
Input High Voltage, V _{IH} Min.	-	1.5, 13.8	-	15	4				-	-	4	V
	-	0.5, 3.8	-	5	3.5				3.5	-	-	
	-	1.8, 8	-	10	7				7	-	-	V
	-	1.5, 13.8	-	15	11				11	-	-	
Output Drive Voltage: High Level V _{OH} Min.	0	-	-	5	4.0	4.0	4.20	4.20	4.10	4.55	-	V
	5	-	-	5	-	-	-	-	-	4.25	-	
	10	-	-	5	3.80	3.80	3.90	3.90	3.90	4.10	-	
	15	-	-	5	-	-	3.50	3.50	-	3.95	-	
	20	-	-	5	3.55	3.55	3.30	-	3.40	3.75	-	
	25	-	-	5	3.40	3.40	-	-	3.10	3.55	-	
	0	-	-	10	9.0	9.0	9.20	9.20	9.10	9.55	-	V
	5	-	-	10	-	-	-	-	-	9.25	-	
	10	-	-	10	8.85	8.85	9.00	9.00	9.00	9.15	-	
	15	-	-	10	-	-	-	-	-	9.05	-	
	20	-	-	10	8.70	8.70	8.40	8.40	8.60	8.90	-	
	25	-	-	10	8.60	8.60	-	-	8.30	8.75	-	
0	-	-	15	14.0	14.0	14.20	14.20	14.10	14.55	-	V	
5	-	-	15	-	-	-	-	-	14.30	-		
10	-	-	15	13.90	13.90	14.0	14.0	14.0	14.20	-		
15	-	-	15	-	-	-	-	-	14.10	-		
20	-	-	15	13.75	13.75	13.50	13.50	13.70	13.95	-		
25	-	-	15	13.65	13.65	-	-	13.50	13.80	-		
Output Low (Sink) Current, I _{OL} Min.	-	0.4	0.5	5	0.64	0.61	0.42	0.36	0.51	1	-	mA
	-	0.5	0.10	10	1.6	1.5	1.1	0.9	1.3	2.6	-	
Input Current, I _{IN} Max.	-	0.18	0.18	18	±0.1	±0.1	±1	±1	-	±10 ⁻⁸	±0.1	μA
	-	-	-	-	-	-	-	-	-	-	-	

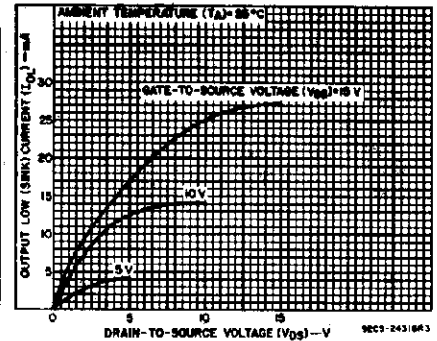

Fig. 1 - Typical output low (sink) current characteristics.

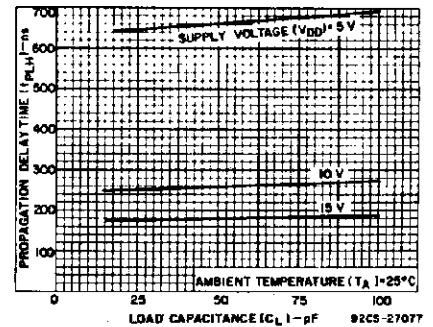

Fig. 2 - Typical data-to-output, low-to-high-level propagation delay time as a function of load capacitance.

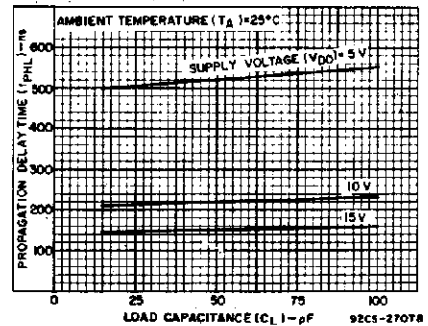

Fig. 3 - Typical data-to-output, high-to-low-level propagation delay time as a function of load capacitance.

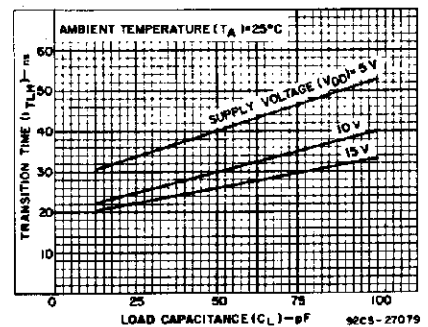

Fig. 4 - Typical low-to-high-level transition time as a function of load capacitance.

CD4511B Types

DYNAMIC ELECTRICAL CHARACTERISTICS at $T_A = 25^\circ\text{C}$, Input $t_r, t_f = 20\text{ ns}$,
 $C_L = 50\text{ pF}$, $R_L = 200\text{ k}\Omega$

CHARACTERISTIC	Test Conditions	LIMITS All Packages			UNITS
		V_{DD} Volts	Min.	Typ.	
Propagation Delay Time: (Data) High-to-Low Level, t_{PHL}	5	—	520	1040	ns
	10	—	210	420	
	15	—	150	300	
Low-to-High Level, t_{PLH}	5	—	660	1320	ns
	10	—	260	520	
	15	—	180	360	
Propagation Delay Time: (BL) High-to-Low Level, t_{PHL}	5	—	350	700	ns
	10	—	175	350	
	15	—	125	250	
Low-to-High Level, t_{PLH}	5	—	400	800	ns
	10	—	175	350	
	15	—	150	300	
Propagation Delay Time: (LT) High-to-Low Level, t_{PHL}	5	—	250	500	ns
	10	—	125	250	
	15	—	85	170	
Low-to-High Level, t_{PLH}	5	—	150	300	ns
	10	—	75	150	
	15	—	50	100	
Transition Time: Low-to-High Level, t_{TLH}	5	—	40	80	ns
	10	—	30	60	
	15	—	25	50	
High-to-Low Level, t_{THL}	5	—	125	310	ns
	10	—	75	185	
	15	—	65	160	
Minimum Set-Up Time, t_S	5	150	75	—	ns
10	70	35	—		
15	40	20	—		
Minimum Hold Time, t_H	5	0	-75	—	ns
	10	0	-35	—	
	15	0	-20	—	
Strobe Pulse Width, t_W	5	400	200	—	ns
	10	160	80	—	
	15	100	50	—	
Input Capacitance, C_{IN}		—	5	7.5	pF

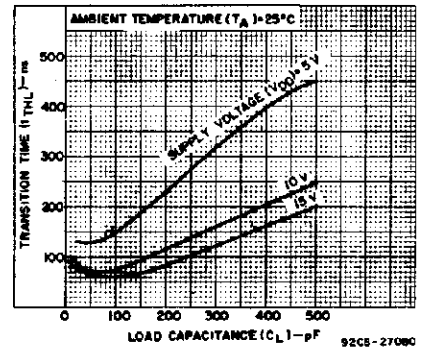

Fig. 5 - Typical high-to-low transition time as a function of load capacitance.

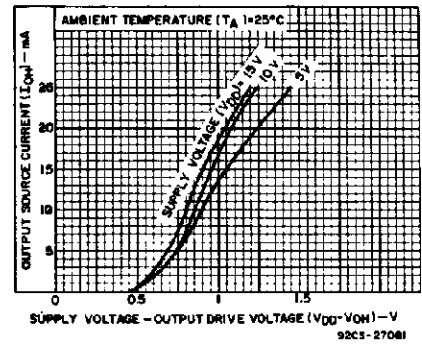

Fig. 6 - Typical voltage drop (V_{DD} to output) vs. output source current as a function of supply.

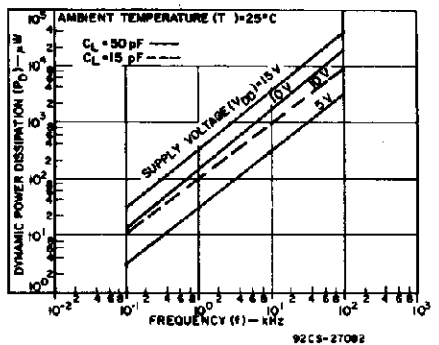

Fig. 7 - Typical dynamic power dissipation characteristics.

3
**COMMERCIAL CMOS
HIGH VOLTAGE ICs**

CD4511B Types

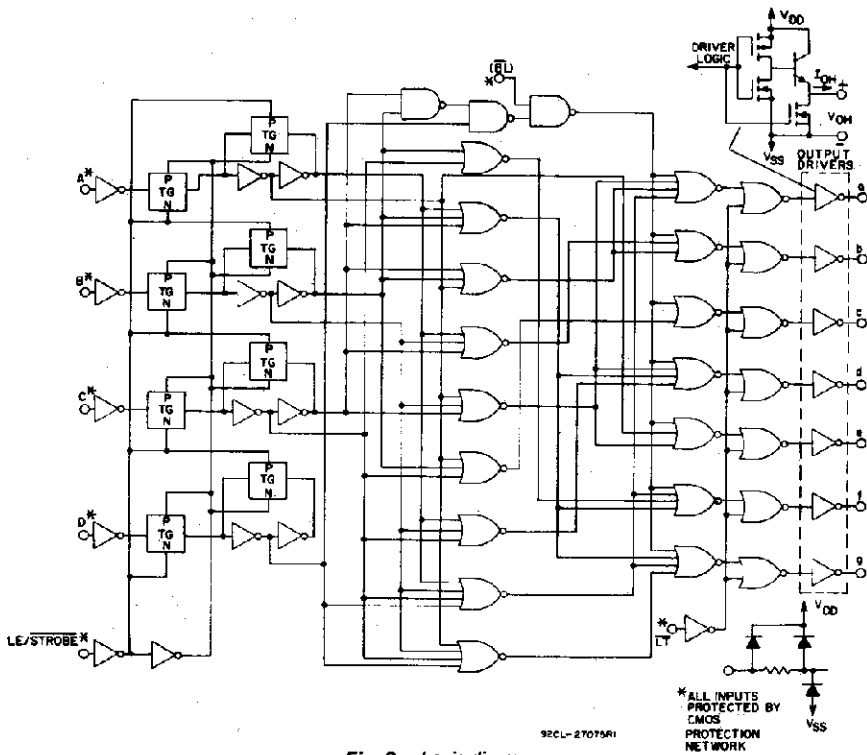

Fig. 8 - Logic diagram.

TRUTH TABLE

LE	BI	LT	D	C	B	A	a	b	c	d	e	f	g	Display
X	X	0	X	X	X	X	1	1	1	1	1	1	1	8
X	0	1	X	X	X	X	0	0	0	0	0	0	0	Blank
0	1	1	0	0	0	0	1	1	1	1	1	1	0	0
0	1	1	0	0	0	1	0	1	1	0	0	0	0	1
0	1	1	0	0	1	0	1	1	0	1	1	0	1	2
0	1	1	0	0	1	1	1	1	1	0	0	1	1	3
0	1	1	0	1	0	0	0	1	1	0	0	1	1	4
0	1	1	0	1	0	1	1	0	1	1	0	1	1	5
0	1	1	0	1	1	0	0	0	1	1	1	1	1	6
0	1	1	0	1	1	1	1	1	1	0	0	0	0	7
0	1	1	1	0	0	0	1	1	1	1	1	1	1	8
0	1	1	1	0	0	1	1	1	1	0	0	1	1	9
0	1	1	1	0	1	0	0	0	0	0	0	0	0	Blank
0	1	1	1	0	1	1	0	0	0	0	0	0	0	Blank
0	1	1	1	1	0	0	0	0	0	0	0	0	0	Blank
0	1	1	1	1	0	1	0	0	0	0	0	0	0	Blank
0	1	1	1	1	1	0	0	0	0	0	0	0	0	Blank
0	1	1	1	1	1	1	0	0	0	0	0	0	0	Blank
1	1	1	X	X	X	X	*	*	*	*	*	*	*	*

X = Don't Care * Depends on BCD code previously applied when LE = 0
 Note: Display is blank for all illegal input codes (BCD > 1001).

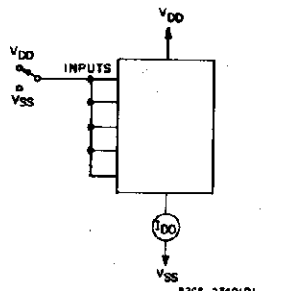

Fig. 9 - Quiescent device current.

TEST CIRCUITS

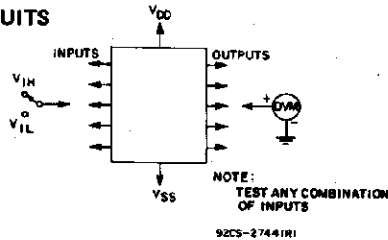

Fig. 10 - Input voltage.

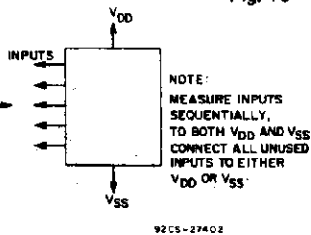

Fig. 11 - Input current.

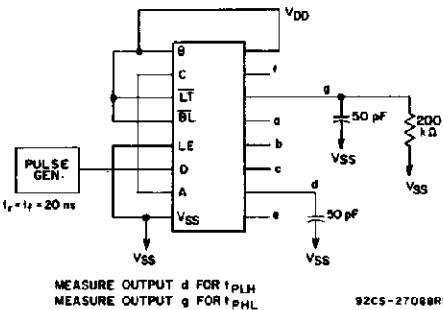

Fig. 12 - Data propagation delay.

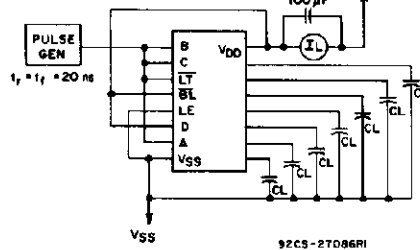
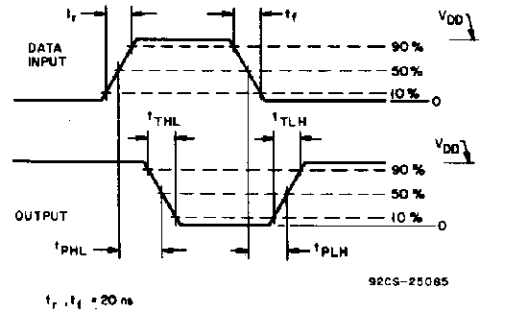

Fig. 13 - Dynamic power dissipation.



$t_r, t_f = 20 \text{ ns}$

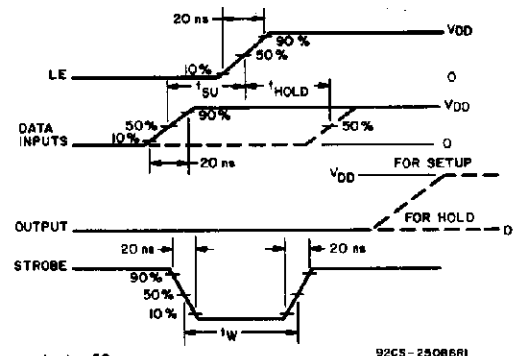
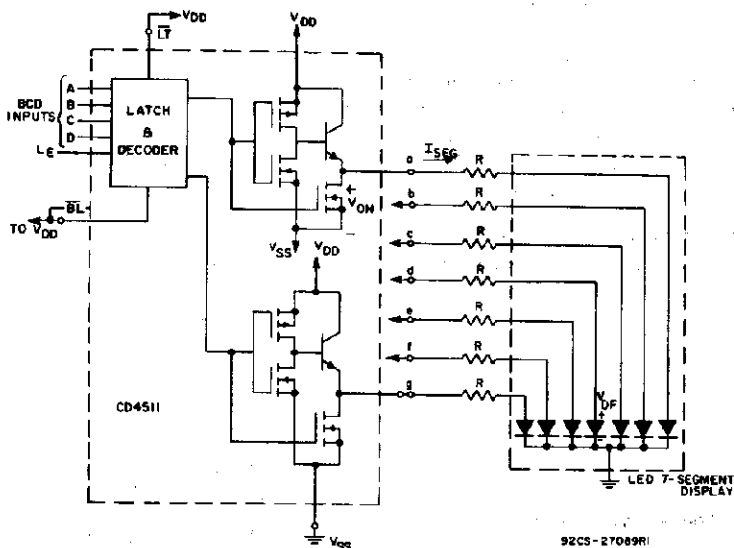

Fig. 14 - Dynamic waveforms.

CD4511B Types

APPLICATIONS Interfacing with Various Displays



Duty Cycle = 100%
 $I_{SEG} = I_{DIODE\ AVG.} = 20\text{ mA at Luminous Intensity/Segment} = 250\text{ microcandles}$
 $R = \frac{V_{OH} - V_{DF}}{I_{SEG}}$

Fig. 15 - Driving common-cathode 7-segment LED displays (example Hewlett-Packard 5082-7740).

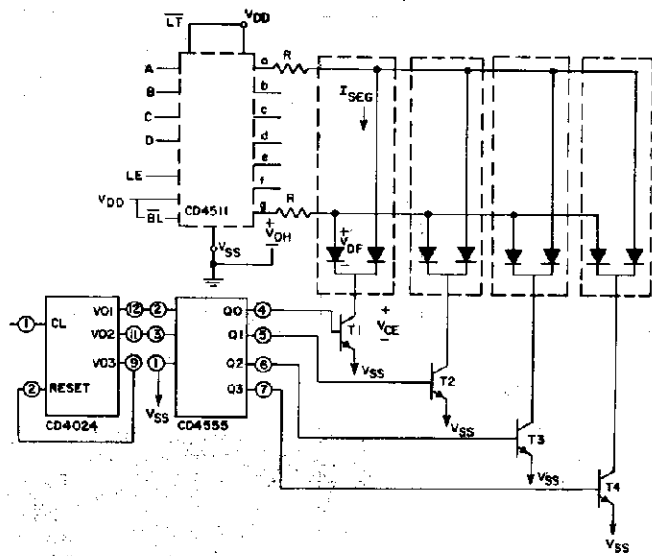

Multiplexing Scheme Showing 2 of 7 Segments Connected
 Transistors $T_1 - T_4$ (RCA-2N3053 or 2N2102) have I_C Max. rating $> 7 \times I_{SEG}$

Duty Cycle = 25%
 $I_{SEG} = [I_{DIODE\ AVG.}] \times 4$
 $R = \frac{(V_{OH} - V_{DF} - V_{CE})}{I_{SEG}}$

All unused inputs on CD4555 are connected to V_{DD} or V_{SS} .

Fig. 18 - Multiplexing with common-cathode 7-segment LED displays (example Hewlett-Packard 5082-7404 4 character display or 4 discrete Monosanto Man 3 displays).

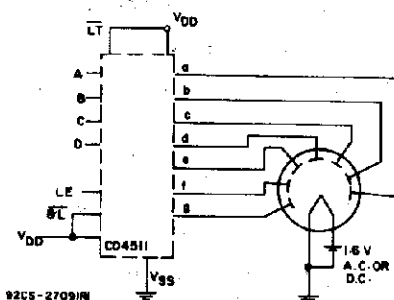

A medium-brightness intensity display can be obtained with low-voltage fluorescent displays such as the Tung-Sol Digivac S/G** Series.

**Trademark Tung-Sol Division Wagner Electric Co.
 Fig. 16 - Driving low-voltage fluorescent displays.

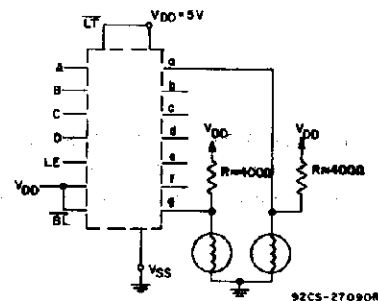

2 of 7 Segments Shown Connected
 Resistors R from V_{DD} to each 7-segment driver output are chosen to keep all Numitron segments slightly on and warm.
 Fig. 17 - Driving incandescent displays (RCA Numitron DR2000 series displays).

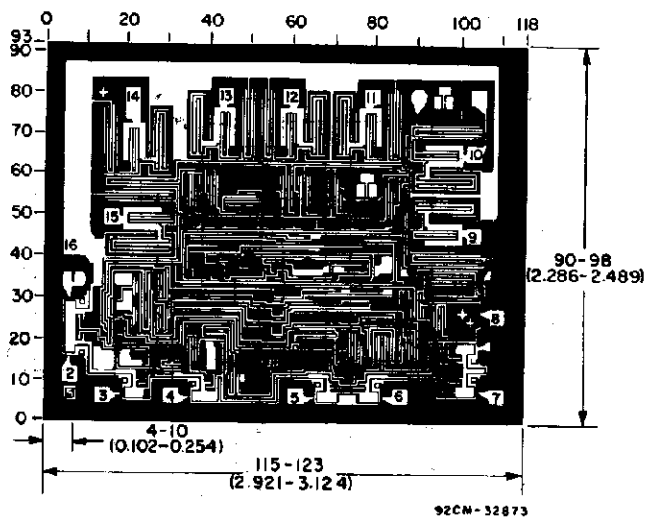

Dimensions and pad layout for CD4511B chip.

Dimensions in parentheses are in millimeters and are derived from the basic inch dimensions as indicated. Grid graduations are in mils (10^{-3} inch).

3
 COMMERCIAL CMOS
 HIGH VOLTAGE ICs

PACKAGING INFORMATION

Orderable Device	Status (1)	Package Type	Package Drawing	Pins	Package Qty	Eco Plan (2)	Lead finish/ Ball material (6)	MSL Peak Temp (3)	Op Temp (°C)	Device Marking (4/5)	Samples
CD4511BE	ACTIVE	PDIP	N	16	25	RoHS & Green	NIPDAU	N / A for Pkg Type	-55 to 125	CD4511BE	Samples
CD4511BEE4	ACTIVE	PDIP	N	16	25	RoHS & Green	NIPDAU	N / A for Pkg Type	-55 to 125	CD4511BE	Samples
CD4511BF	ACTIVE	CDIP	J	16	1	Non-RoHS & Non-Green	SNPB	N / A for Pkg Type	-55 to 125	CD4511BF	Samples
CD4511BF3A	ACTIVE	CDIP	J	16	1	Non-RoHS & Non-Green	SNPB	N / A for Pkg Type	-55 to 125	CD4511BF3A	Samples
CD4511BNSR	ACTIVE	SO	NS	16	2000	RoHS & Green	NIPDAU	Level-1-260C-UNLIM	-55 to 125	CD4511B	Samples
CD4511BNSRG4	ACTIVE	SO	NS	16	2000	RoHS & Green	NIPDAU	Level-1-260C-UNLIM	-55 to 125	CD4511B	Samples
CD4511BPW	ACTIVE	TSSOP	PW	16	90	RoHS & Green	NIPDAU	Level-1-260C-UNLIM	-55 to 125	CM511B	Samples
CD4511BPWG4	ACTIVE	TSSOP	PW	16	90	RoHS & Green	NIPDAU	Level-1-260C-UNLIM	-55 to 125	CM511B	Samples
CD4511BPWR	ACTIVE	TSSOP	PW	16	2000	RoHS & Green	NIPDAU	Level-1-260C-UNLIM	-55 to 125	CM511B	Samples

(1) The marketing status values are defined as follows:

ACTIVE: Product device recommended for new designs.

LIFEBUY: TI has announced that the device will be discontinued, and a lifetime-buy period is in effect.

NRND: Not recommended for new designs. Device is in production to support existing customers, but TI does not recommend using this part in a new design.

PREVIEW: Device has been announced but is not in production. Samples may or may not be available.

OBSOLETE: TI has discontinued the production of the device.

(2) **RoHS:** TI defines "RoHS" to mean semiconductor products that are compliant with the current EU RoHS requirements for all 10 RoHS substances, including the requirement that RoHS substance do not exceed 0.1% by weight in homogeneous materials. Where designed to be soldered at high temperatures, "RoHS" products are suitable for use in specified lead-free processes. TI may reference these types of products as "Pb-Free".

RoHS Exempt: TI defines "RoHS Exempt" to mean products that contain lead but are compliant with EU RoHS pursuant to a specific EU RoHS exemption.

Green: TI defines "Green" to mean the content of Chlorine (Cl) and Bromine (Br) based flame retardants meet JS709B low halogen requirements of <=1000ppm threshold. Antimony trioxide based flame retardants must also meet the <=1000ppm threshold requirement.

(3) MSL, Peak Temp. - The Moisture Sensitivity Level rating according to the JEDEC industry standard classifications, and peak solder temperature.

(4) There may be additional marking, which relates to the logo, the lot trace code information, or the environmental category on the device.

⁽⁵⁾ Multiple Device Markings will be inside parentheses. Only one Device Marking contained in parentheses and separated by a "~" will appear on a device. If a line is indented then it is a continuation of the previous line and the two combined represent the entire Device Marking for that device.

⁽⁶⁾ Lead finish/Ball material - Orderable Devices may have multiple material finish options. Finish options are separated by a vertical ruled line. Lead finish/Ball material values may wrap to two lines if the finish value exceeds the maximum column width.

Important Information and Disclaimer: The information provided on this page represents TI's knowledge and belief as of the date that it is provided. TI bases its knowledge and belief on information provided by third parties, and makes no representation or warranty as to the accuracy of such information. Efforts are underway to better integrate information from third parties. TI has taken and continues to take reasonable steps to provide representative and accurate information but may not have conducted destructive testing or chemical analysis on incoming materials and chemicals. TI and TI suppliers consider certain information to be proprietary, and thus CAS numbers and other limited information may not be available for release.

In no event shall TI's liability arising out of such information exceed the total purchase price of the TI part(s) at issue in this document sold by TI to Customer on an annual basis.

OTHER QUALIFIED VERSIONS OF CD4511B, CD4511B-MIL :

- Catalog: [CD4511B](#)
- Military: [CD4511B-MIL](#)

NOTE: Qualified Version Definitions:

- Catalog - TI's standard catalog product
- Military - QML certified for Military and Defense Applications

TAPE AND REEL INFORMATION

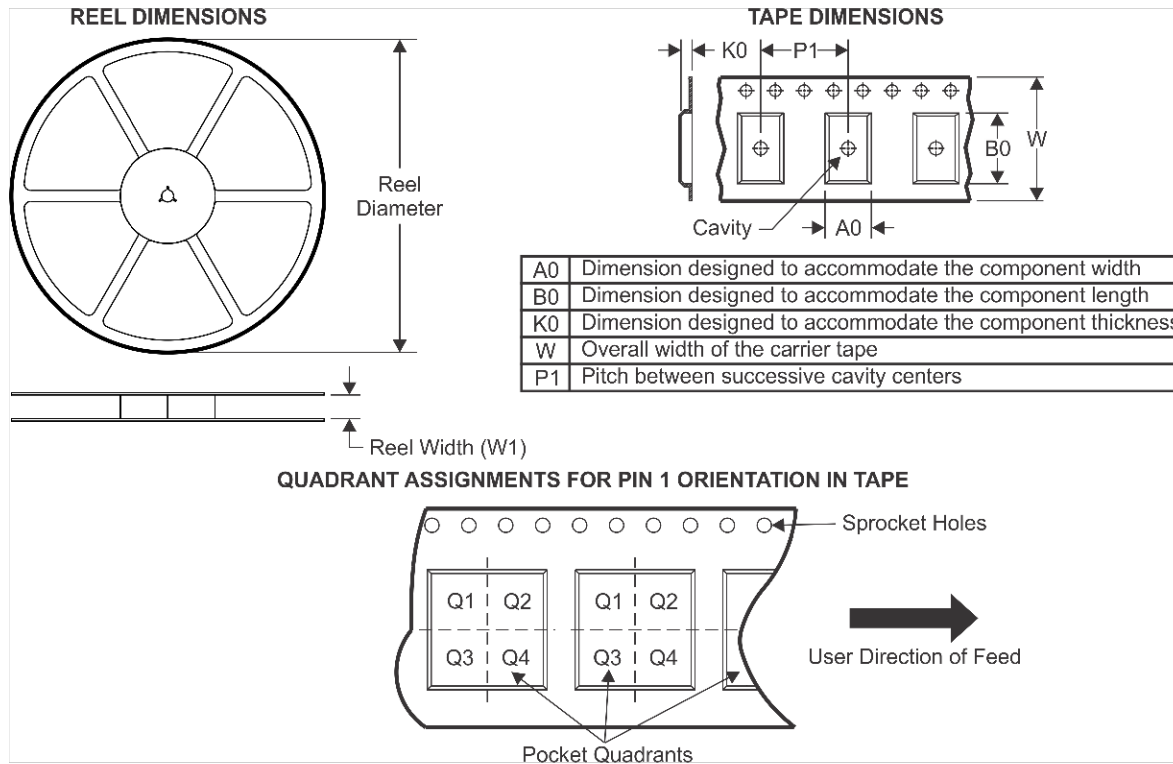

*All dimensions are nominal

Device	Package Type	Package Drawing	Pins	SPQ	Reel Diameter (mm)	Reel Width W1 (mm)	A0 (mm)	B0 (mm)	K0 (mm)	P1 (mm)	W (mm)	Pin1 Quadrant
CD4511BNSR	SO	NS	16	2000	330.0	16.4	8.2	10.5	2.5	12.0	16.0	Q1
CD4511BPWR	TSSOP	PW	16	2000	330.0	12.4	6.9	5.6	1.6	8.0	12.0	Q1

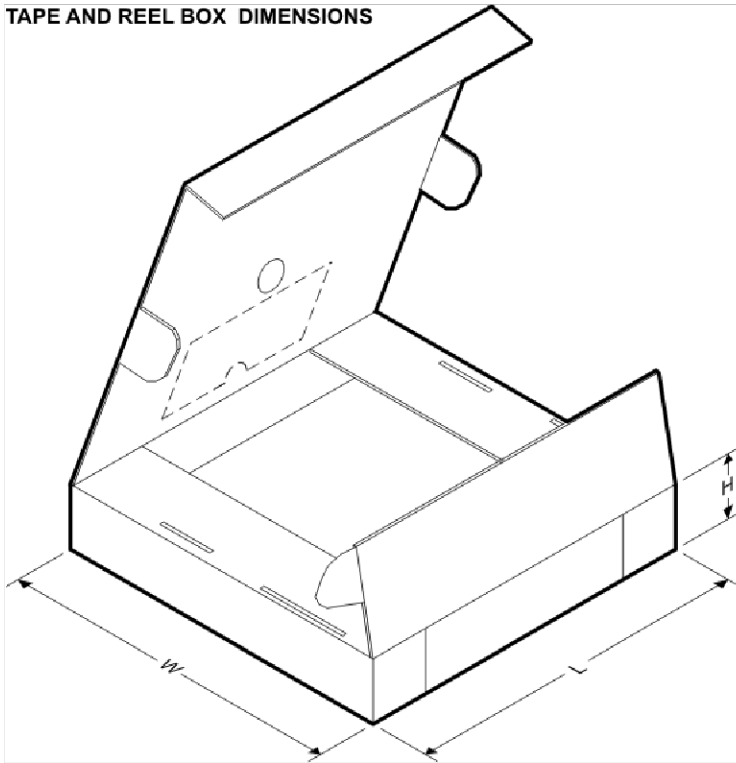
TAPE AND REEL BOX DIMENSIONS

*All dimensions are nominal

Device	Package Type	Package Drawing	Pins	SPQ	Length (mm)	Width (mm)	Height (mm)
CD4511BNSR	SO	NS	16	2000	367.0	367.0	38.0
CD4511BPWR	TSSOP	PW	16	2000	853.0	449.0	35.0

PW0016A

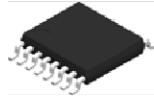

PACKAGE OUTLINE

TSSOP - 1.2 mm max height

SMALL OUTLINE PACKAGE

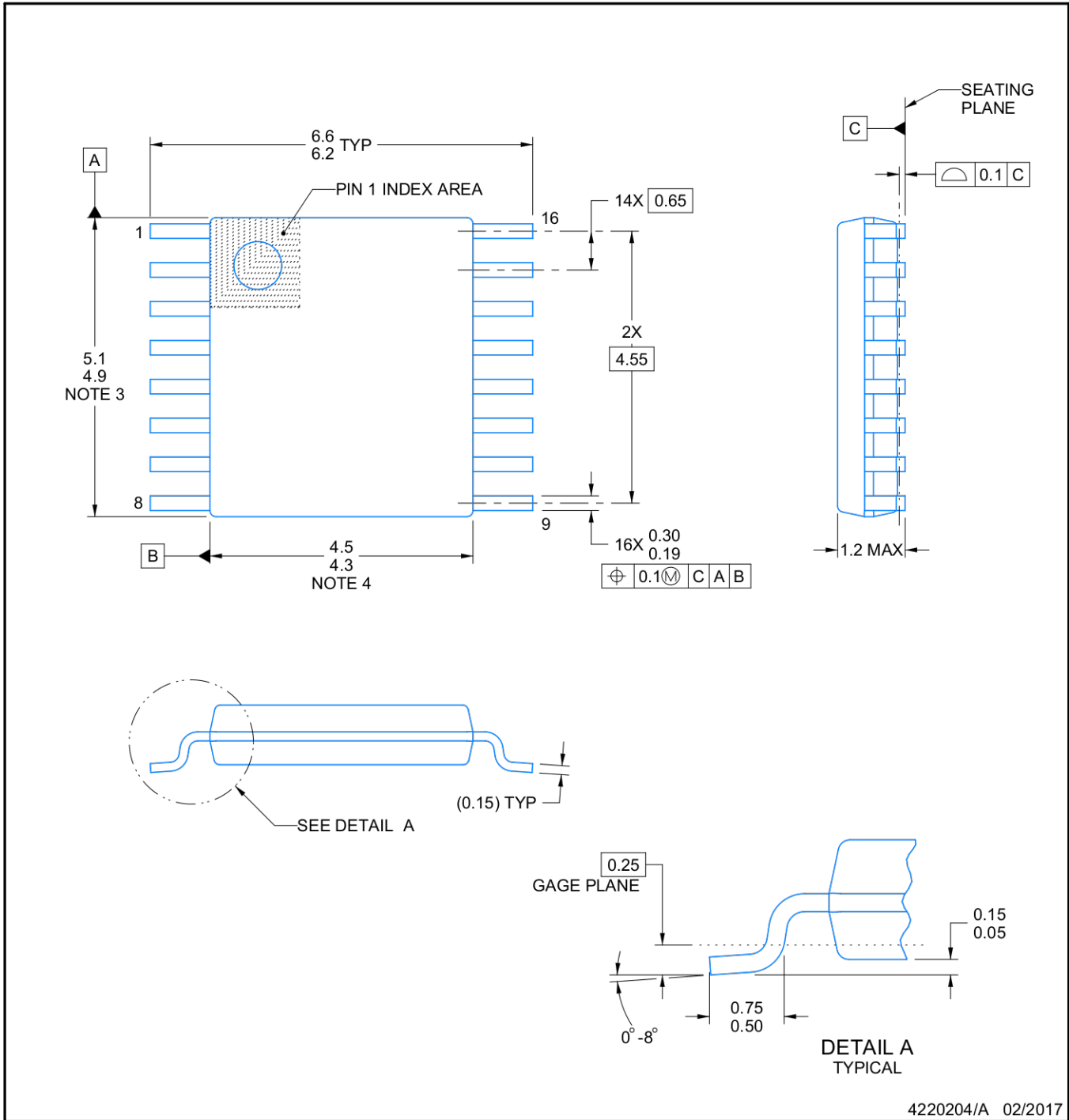

4220204/A 02/2017

NOTES:

1. All linear dimensions are in millimeters. Any dimensions in parenthesis are for reference only. Dimensioning and tolerancing per ASME Y14.5M.
2. This drawing is subject to change without notice.
3. This dimension does not include mold flash, protrusions, or gate burrs. Mold flash, protrusions, or gate burrs shall not exceed 0.15 mm per side.
4. This dimension does not include interlead flash. Interlead flash shall not exceed 0.25 mm per side.
5. Reference JEDEC registration MO-153.

EXAMPLE BOARD LAYOUT

PW0016A

TSSOP - 1.2 mm max height

SMALL OUTLINE PACKAGE

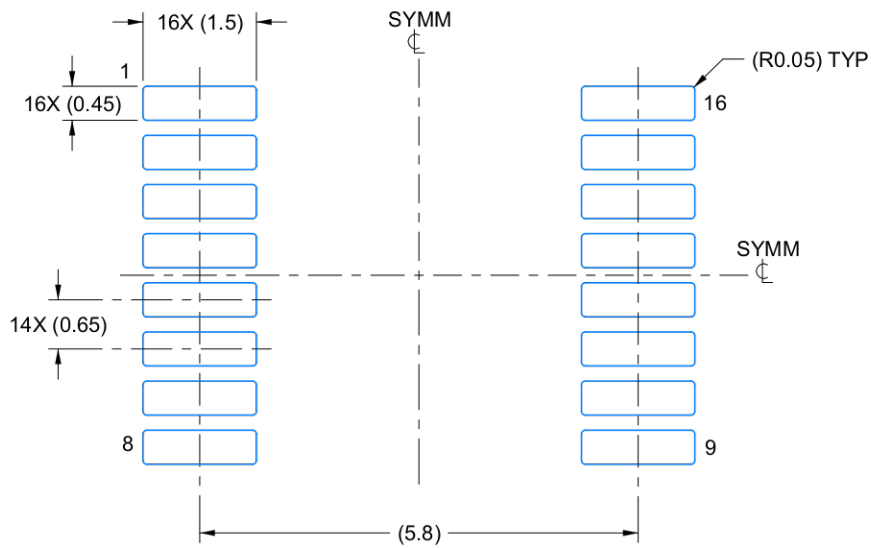

LAND PATTERN EXAMPLE
EXPOSED METAL SHOWN
SCALE: 10X

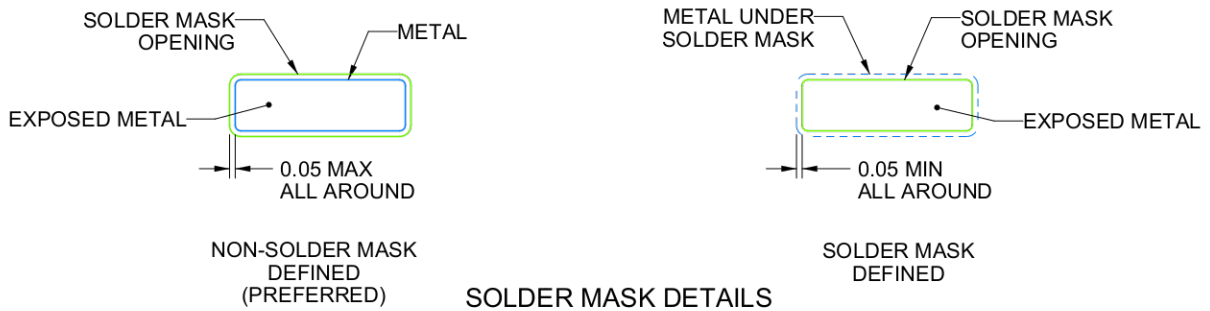

SOLDER MASK DETAILS

4220204/A 02/2017

NOTES: (continued)

- 6. Publication IPC-7351 may have alternate designs.
- 7. Solder mask tolerances between and around signal pads can vary based on board fabrication site.

EXAMPLE STENCIL DESIGN

PW0016A

TSSOP - 1.2 mm max height

SMALL OUTLINE PACKAGE

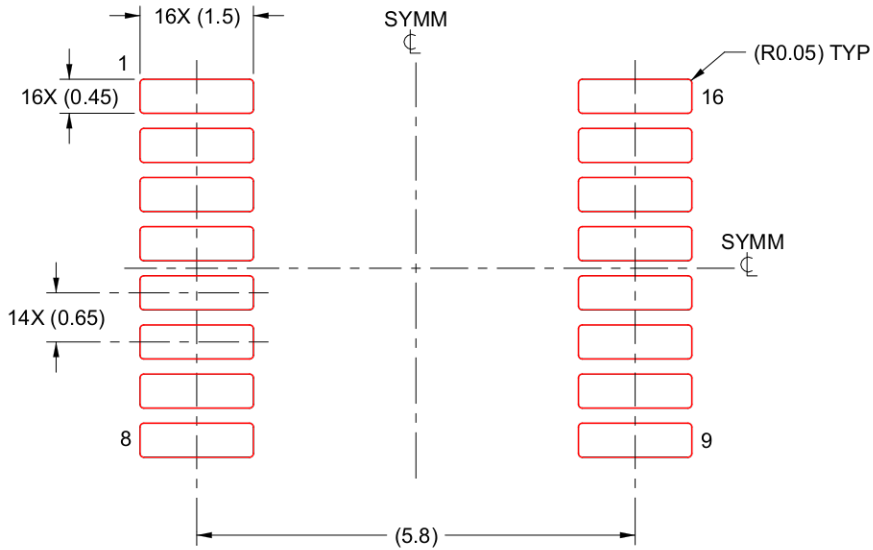

SOLDER PASTE EXAMPLE
BASED ON 0.125 mm THICK STENCIL
SCALE: 10X

4220204/A 02/2017

NOTES: (continued)

8. Laser cutting apertures with trapezoidal walls and rounded corners may offer better paste release. IPC-7525 may have alternate design recommendations.
9. Board assembly site may have different recommendations for stencil design.

MECHANICAL DATA

NS (R-PDSO-G**)

PLASTIC SMALL-OUTLINE PACKAGE

14-PINS SHOWN

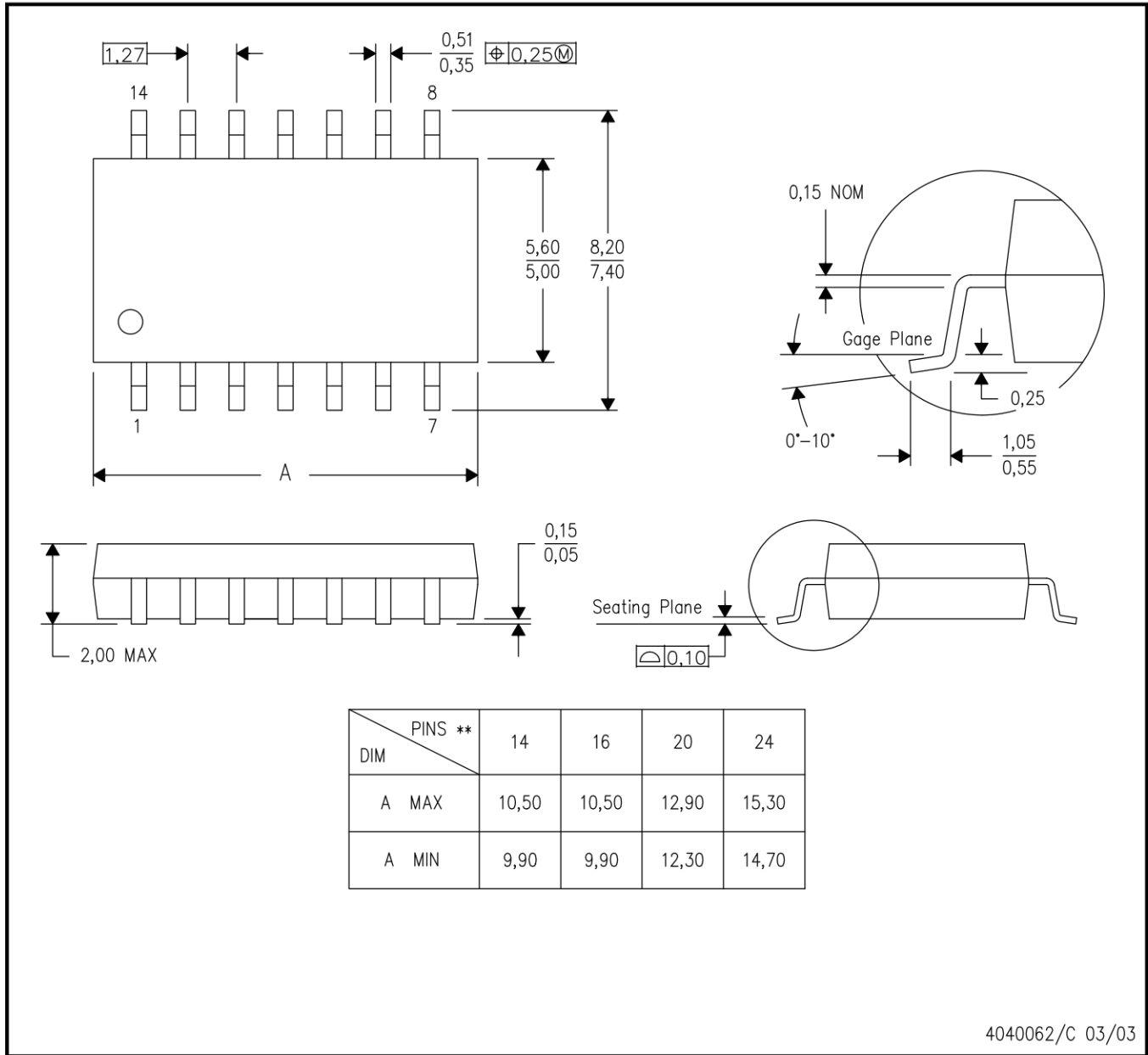

- NOTES:
- A. All linear dimensions are in millimeters.
 - B. This drawing is subject to change without notice.
 - C. Body dimensions do not include mold flash or protrusion, not to exceed 0,15.

J (R-GDIP-T**)
14 LEADS SHOWN

CERAMIC DUAL IN-LINE PACKAGE

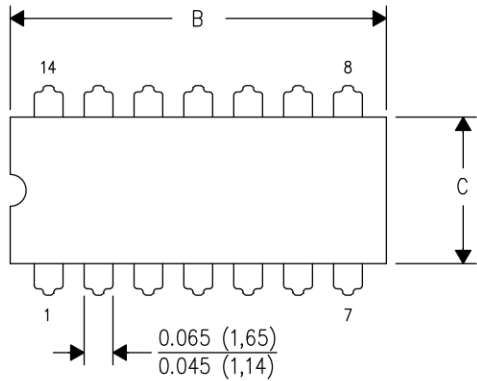

DIM \ PINS **	14	16	18	20
A	0.300 (7,62) BSC	0.300 (7,62) BSC	0.300 (7,62) BSC	0.300 (7,62) BSC
B MAX	0.785 (19,94)	.840 (21,34)	0.960 (24,38)	1.060 (26,92)
B MIN	—	—	—	—
C MAX	0.300 (7,62)	0.300 (7,62)	0.310 (7,87)	0.300 (7,62)
C MIN	0.245 (6,22)	0.245 (6,22)	0.220 (5,59)	0.245 (6,22)

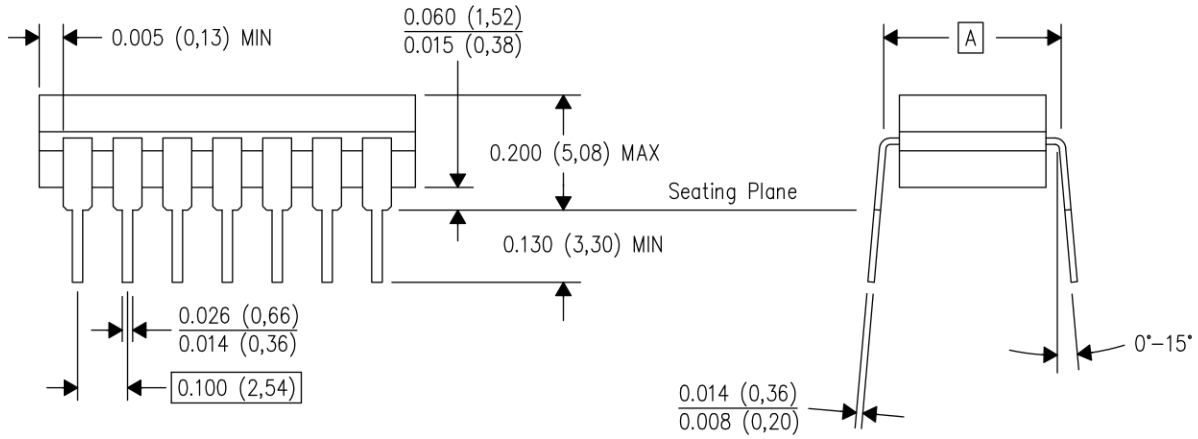

4040083/F 03/03

- NOTES:
- All linear dimensions are in inches (millimeters).
 - This drawing is subject to change without notice.
 - This package is hermetically sealed with a ceramic lid using glass frit.
 - Index point is provided on cap for terminal identification only on press ceramic glass frit seal only.
 - Falls within MIL STD 1835 GDIP1-T14, GDIP1-T16, GDIP1-T18 and GDIP1-T20.

N (R-PDIP-T**)

PLASTIC DUAL-IN-LINE PACKAGE

16 PINS SHOWN

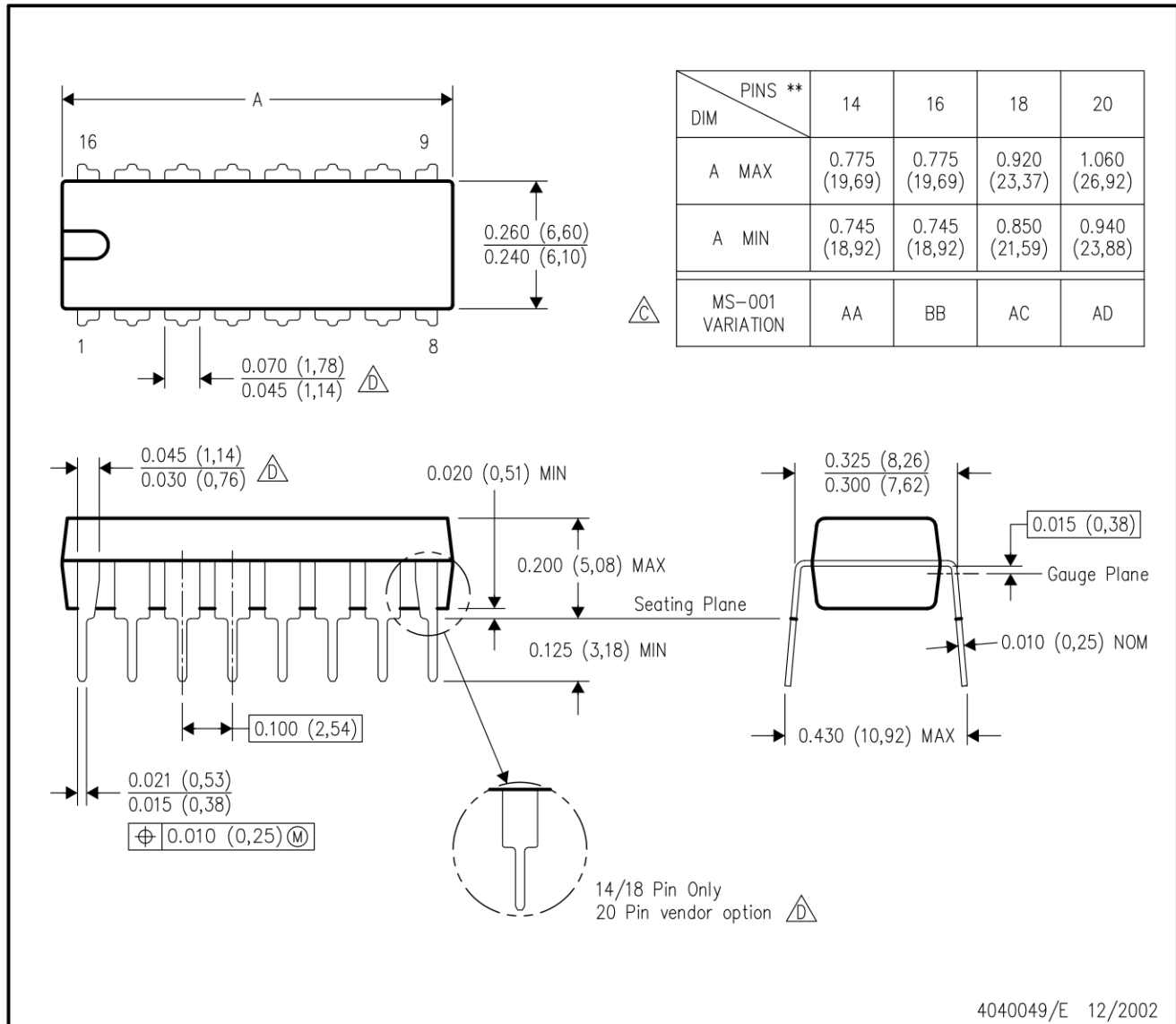

4040049/E 12/2002

- NOTES:
- A. All linear dimensions are in inches (millimeters).
 - B. This drawing is subject to change without notice.
 - Falls within JEDEC MS-001, except 18 and 20 pin minimum body length (Dim A).
 - The 20 pin end lead shoulder width is a vendor option, either half or full width.

IMPORTANT NOTICE AND DISCLAIMER

TI PROVIDES TECHNICAL AND RELIABILITY DATA (INCLUDING DATASHEETS), DESIGN RESOURCES (INCLUDING REFERENCE DESIGNS), APPLICATION OR OTHER DESIGN ADVICE, WEB TOOLS, SAFETY INFORMATION, AND OTHER RESOURCES "AS IS" AND WITH ALL FAULTS, AND DISCLAIMS ALL WARRANTIES, EXPRESS AND IMPLIED, INCLUDING WITHOUT LIMITATION ANY IMPLIED WARRANTIES OF MERCHANTABILITY, FITNESS FOR A PARTICULAR PURPOSE OR NON-INFRINGEMENT OF THIRD PARTY INTELLECTUAL PROPERTY RIGHTS.

These resources are intended for skilled developers designing with TI products. You are solely responsible for (1) selecting the appropriate TI products for your application, (2) designing, validating and testing your application, and (3) ensuring your application meets applicable standards, and any other safety, security, or other requirements. These resources are subject to change without notice. TI grants you permission to use these resources only for development of an application that uses the TI products described in the resource. Other reproduction and display of these resources is prohibited. No license is granted to any other TI intellectual property right or to any third party intellectual property right. TI disclaims responsibility for, and you will fully indemnify TI and its representatives against, any claims, damages, costs, losses, and liabilities arising out of your use of these resources.

TI's products are provided subject to TI's Terms of Sale (www.ti.com/legal/termsofsale.html) or other applicable terms available either on ti.com or provided in conjunction with such TI products. TI's provision of these resources does not expand or otherwise alter TI's applicable warranties or warranty disclaimers for TI products.

Mailing Address: Texas Instruments, Post Office Box 655303, Dallas, Texas 75265
Copyright © 2020, Texas Instruments Incorporated