

# SN74HC4851 8-Channel Analog Multiplexer/Demultiplexer With Injection-Current Effect Control

## 1 Features

- Injection-current cross coupling <math><1\text{mV/mA}</math> (see [Section 8.1](#) in *Application Information*)
- Low crosstalk between switches
- Terminal compatible with SN74HC4051, SN74LV4051A, and CD4051B devices
- 2V to 5.5V  $V_{CC}$  operation
- Latch-up performance exceeds 100mA per JESD 78, class II

## 2 Applications

- Analog and digital multiplexing and demultiplexing
- Diagnostics and monitoring
- Data center switch
- Remote radio unit (RRU)
- Rack server
- Electricity meter
- Appliances
- Air conditioner units
- Multifunction printers
- String inverter
- IP network camera
- Currency counters
- Off-highway vehicles control systems
- [Digital radio](#)

## 3 Description

This eight-channel CMOS analog multiplexer/demultiplexer is terminal compatible with the function of the '4051 device, and features injection-current effect control, which has excellent value in automotive applications where voltages in excess of normal supply voltages are common.

The injection-current effect control allows signals at disabled analog input channels to exceed the supply voltage without affecting the signal of the enabled analog channel. This feature eliminates the need for external diode/resistor networks typically used to keep the analog channel signals within the supply-voltage range.

### Package Information

PART NUMBER	PACKAGE <sup>(1)</sup>	PACKAGE SIZE <sup>(2)</sup>
SN74HC4851	PW (TSSOP, 16)	5mm × 6.4mm

- (1) For more information, see [Section 11](#)
- (2) The package size (length × width) is a nominal value and includes pins, where applicable.

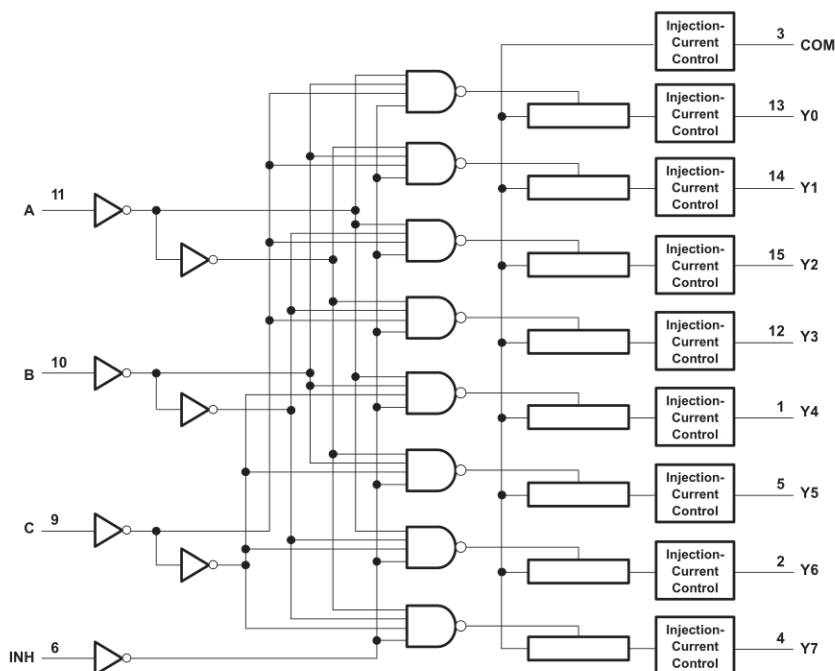

Logic Diagram (Positive Logic)



## Table of Contents

<b>1 Features</b> .....	<b>1</b>	<b>7 Detailed Description</b> .....	<b>9</b>
<b>2 Applications</b> .....	<b>1</b>	7.1 Functional Block Diagram.....	9
<b>3 Description</b> .....	<b>1</b>	<b>8 Application and Implementation</b> .....	<b>10</b>
<b>4 Pin Configuration and Functions</b> .....	<b>2</b>	8.1 Application Information.....	10
<b>5 Specifications</b> .....	<b>3</b>	<b>9 Device and Documentation Support</b> .....	<b>12</b>
5.1 Absolute Maximum Ratings.....	3	9.1 Receiving Notification of Documentation Updates....	12
5.2 ESD Ratings.....	3	9.2 Support Resources.....	12
5.3 Thermal Information: SN74HC485x.....	3	9.3 Trademarks.....	12
5.4 Recommended Operating Conditions.....	4	9.4 Electrostatic Discharge Caution.....	12
5.5 Electrical Characteristics.....	5	9.5 Glossary.....	12
5.6 Timing Characteristics.....	6	<b>10 Revision History</b> .....	<b>12</b>
5.7 Injection Current Coupling.....	6	<b>11 Mechanical, Packaging, and Orderable</b>	
<b>6 Parameter Measurement Information</b> .....	<b>7</b>	<b>Information</b> .....	<b>12</b>

## 4 Pin Configuration and Functions

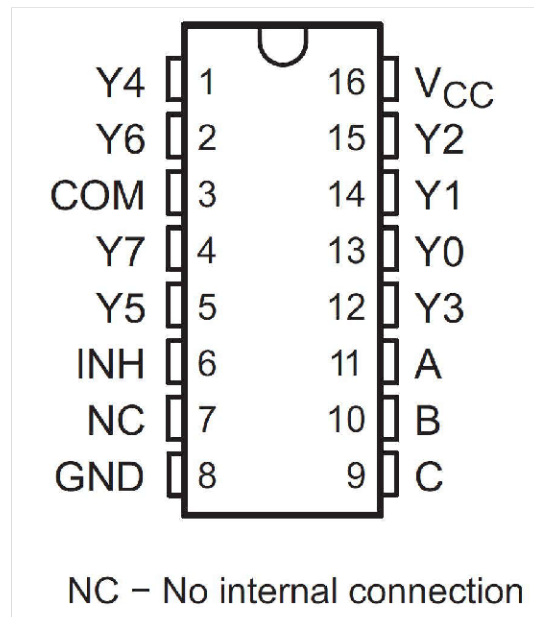

Figure 4-1. SN74HC4851 PW Package, 16-Pin TSSOP (Top View)

Table 4-1. Function Table

Inputs				On Channel
INH	C	B	A	Yx
L	L	L	L	Y0
L	L	L	H	Y1
L	L	H	L	Y2
L	L	H	H	Y3
L	H	L	L	Y4
L	H	L	H	Y5
L	H	H	L	Y6
L	H	H	H	Y7
H	X	X	X	None

## 5 Specifications

### 5.1 Absolute Maximum Ratings

over operating free-air temperature range (unless otherwise noted)<sup>(1) (2)</sup>

		MIN	MAX	UNIT
$V_{CC}$	Supply voltage	-0.5	6	V
$V_{SEL}$ or $V_{EN}$	Logic control input pin voltage ( $\overline{EN}$ , A0, A1, A2)	-0.5	$V_{CC}+0.5V$	V
$V_S$ or $V_D$	Source or drain voltage (Sx, D)	-0.5	$V_{CC}+0.5V$	V
$I_{IK}$	Input clamp current ( $V_I < 0$ or $V_I > V_{CC}$ )	-20	20	mA
$I_{IOK}$	I/O diode current ( $V_{IO} < 0$ or $V_{IO} > V_{CC}$ )	-20	20	mA
$I_T$	Switch through current ( $V_{IO} = 0$ to $V_{CC}$ )	-25	25	mA
$I_{GND}$	Continuous current through $V_{CC}$ or GND	-50	50	mA
$T_{stg}$	Storage temperature	-65	150	°C
$T_J$	Junction temperature		150	

- (1) Operation outside the *Absolute Maximum Ratings* may cause permanent device damage. Absolute maximum ratings do not imply functional operation of the device at these or any other conditions beyond those listed under *Recommended Operating Conditions*. If briefly operating outside the *Recommended Operating Conditions* but within the *Absolute Maximum Ratings*, the device may not sustain damage, but it may not be fully functional. Operating the device in this manner may affect device reliability, functionality, performance, and shorten the device lifetime.
- (2) The input and output voltage ratings may be exceeded if the input and output current ratings are observed.

### 5.2 ESD Ratings

			VALUE	UNIT
$V_{(ESD)}$	Electrostatic discharge	Human body model (HBM), per AEC Q100-002 <sup>(1)</sup>	±2000	V
		Charged device model (CDM), per AEC Q100-011	±750	

- (1) AEC Q100-002 indicates that HBM stressing shall be in accordance with the ANSI/ESDA/JEDEC JS-001 specification.

### 5.3 Thermal Information: SN74HC485x

	THERMAL METRIC <sup>(1)</sup>	SN74HC485x	UNIT
		PW (TSSOP)	
		PINS	
$R_{\theta JA}$	Junction-to-ambient thermal resistance	139.6	°C/W

- (1) For more information about traditional and new thermal metrics, see the [Semiconductor and IC Package Thermal Metrics](#) application report.

## 5.4 Recommended Operating Conditions

over operating free-air temperature range (unless otherwise noted)

			MIN	NOM	MAX	UNIT
$V_{CC}$	Supply voltage		2		5.5	V
$V_{IH}$	Input logic high	2V	1.5			V
		2.5V	2.1			
		3.3V	2.3			
		4.5V	3.15			
		5.5V	4.2			
$V_{IL}$	Input logic low	2V	0	0.5		V
		2.5V	0	0.7		
		3.3V	0	0.8		
		4.5V	0	0.95		
		5.5V	0	1.05		
$V_{SEL}$ or $V_{EN}$	Logic control input pin voltage ( $\overline{EN}$ , A0, A1, A2)		0		$V_{CC}$	V
$V_S$ or $V_D$	Signal path input/output voltage (source or drain pin) (Sx, D)		0		$V_{CC}$	V
$\Delta t/\Delta v$	Input transition rise or fall time	$V_{CC} = 2V$			1000	ns
		$V_{CC} = 3V$			800	
		$V_{CC} = 3.3V$			700	
		$V_{CC} = 4.5V$			500	
		$V_{CC} = 5.5V$			400	
$T_A$	Ambient temperature		-40		125	°C

## 5.5 Electrical Characteristics

At specified  $V_{CC} \pm 10\%$

Typical values measured at nominal  $V_{CC}$ .

PARAMETER		TEST CONDITIONS	$V_{CC}$	Operating free-air temperature ( $T_A$ )									UNIT
				25°C			–40°C to 85°C			–40°C to 125°C			
				MIN	TYP	MAX	MIN	TYP	MAX	MIN	TYP	MAX	
$R_{ON}$	On-state switch resistance	$V_S = 0V$ to $V_{CC}$ $I_{SD} = 0.5mA$	2V	500	650		670		700			$\Omega$	
			3V	215	280		320		360				
			3.3V	210	270		305		345				
			4.5V	160	210		240		270				
$\Delta_{RON}$	On-state switch resistance matching between inputs	$V_S = V_{CC} / 2$ $I_{SD} = 0.5mA$	2V	4	10		15		20			$\Omega$	
			3V	2	8		12		16				
			3.3V	2	8		12		16				
			4.5V	2	8		12		16				
$I_I$	Control input current	$V_I = V_{CC}$ or GND	5V		$\pm 0.1$		$\pm 0.1$		$\pm 1$		$\mu A$		
$I_{S(OFF)}$	Off-state switch leakage current (any one channel)	Switch Off $V_{INH} = V_{IH}$ $V_D = V_{CC} / GND$ $V_S = GND / V_{CC}$	5V		$\pm 0.1$		$\pm 0.5$		$\pm 1$		$\mu A$		
	Off-state switch leakage current (common channel)				$\pm 0.2$		$\pm 2$		$\pm 4$		$\mu A$		
$I_{S(ON)}$	Channel on-state leakage current	Switch Off $V_{INH} = V_{IL}$ $V_D = V_{CC} / GND$ $V_S = GND / V_{CC}$	5V		$\pm 0.1$		$\pm 0.5$		$\pm 1$		$\mu A$		
$I_{DD}$	$V_{CC}$ supply current	Logic inputs = 0V or $V_{CC}$	5V		2		20		40		$\mu A$		
$C_{IC}$	Control input capacitance	A, B, C, INH		3.5	10		10		10		pF		
$C_{IS}$	Common terminal capacitance	Switch off		22	40		40		40		pF		
$C_{OS}$	Switch terminal capacitance	Switch off		6.7	15		15		15		pF		
$C_{PD}$	Power Dissipation Capacitance	No Load $t_r = t_f = 1ns$ $f = 1MHz$	3.3V	32							pF		
			5V	37									

## 5.6 Timing Characteristics

At specified  $V_{CC} \pm 10\%$

Typical values measured at nominal  $V_{CC}$ .

PARAMETER	TEST CONDITIONS	$V_{CC}$	Operating free-air temperature ( $T_A$ )									UNIT
			25°C			-40°C to 85°C			-40°C to 125°C			
			MIN	TYP	MAX	MIN	TYP	MAX	MIN	TYP	MAX	
SWITCHING CHARACTERISTICS <sup>(1)</sup>												
$t_{PD}$	Propagation delay	$C_L = 50\text{pF}$ Sx to D, D to Sx	2V	19.5	25		29		32		ns	
			3V	12	15.5		17.5		19.5			
			3.3V	11	14.5		16.5		18.5			
			5V	8.6	11.5		12.5		13.5			
$t_{TRAN}$	Transition-time between inputs	$R_L = 10\text{k}\Omega$ , $C_L = 50\text{pF}$ Ax to D, Ax to Sx	2V	44	94		103		103		ns	
			3V	30	63		67		67			
			3.3V	23	51		54		54			
			5V	18	43		46		46			
$t_{ON(EN)}$	Turnon-time from enable	$R_L = 10\text{k}\Omega$ , $C_L = 50\text{pF}$ EN to D, EN to Sx	2V		95		105		115		ns	
			3V		90		100		110			
			3.3V		85		95		105			
			5V		80		90		100			
$t_{OFF(EN)}$	Turnoff time from enable	$R_L = 10\text{k}\Omega$ , $C_L = 50\text{pF}$ EN to D, EN to Sx	2V		95		105		115		ns	
			3V		90		100		110			
			3.3V		85		95		105			
			5V		80		90		100			

(1)  $t_{PLH}/t_{PHL} = t_{PD}$  propagation delay time,  $t_{PZH}/t_{PLZ} = t_{ON(EN)}$  enable delay time,  $t_{PHZ}/t_{PLZ} = t_{OFF(EN)}$  disable delay time,  $t_{PLH}/t_{PHL}$  Channel select =  $t_{TRAN}$

## 5.7 Injection Current Coupling

At specified  $V_{CC} \pm 10\%$

Typical values measured at nominal  $V_{CC}$  and  $T_A = 25^\circ\text{C}$ .

PARAMETER	$V_{CC}$	TEST CONDITIONS	-40°C to 125°C			UNIT	
			MIN	TYP	MAX		
INJECTION CURRENT COUPLING							
$\Delta V_{OUT}$	Maximum shift of output voltage of enabled analog input <sup>(1)</sup>	3.3V	$R_S \leq 3.9\text{k}\Omega$	$I_{INJ} \leq 1\text{mA}$	0.05	1	mV
		5V			0.1	1	
		3.3V		$I_{INJ} \leq 10\text{mA}$	0.345	5	
		5V			0.067	5	
		3.3V	$R_S \leq 20\text{k}\Omega$	$I_{INJ} \leq 1\text{mA}$	0.05	2	
		5V			0.11	2	
		3.3V		$I_{INJ} \leq 10\text{mA}$	0.05	20	
		5V			0.024	20	

(1)  $I_{INJ}$  = total current injected into all disabled channels

## 6 Parameter Measurement Information

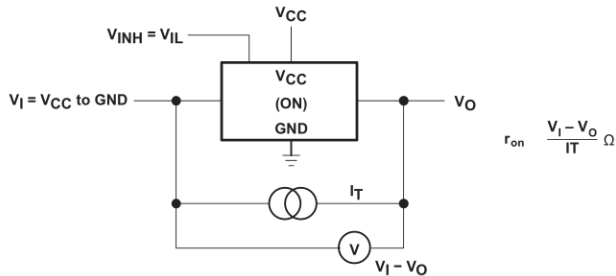

Figure 6-1. On-State-Resistance Test Circuit

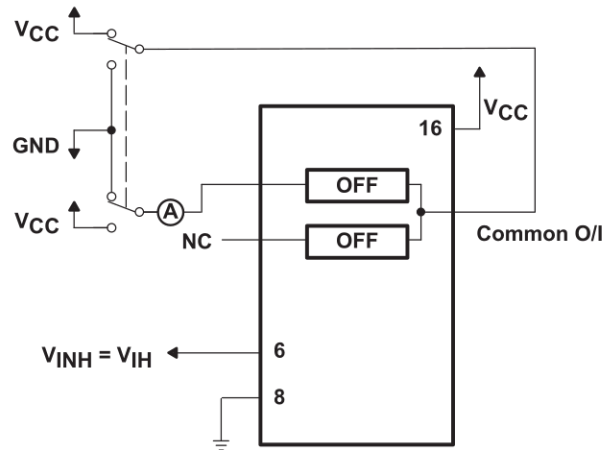

Figure 6-2. Maximum Off-Channel Leakage Current, Any One Channel, Test Setup

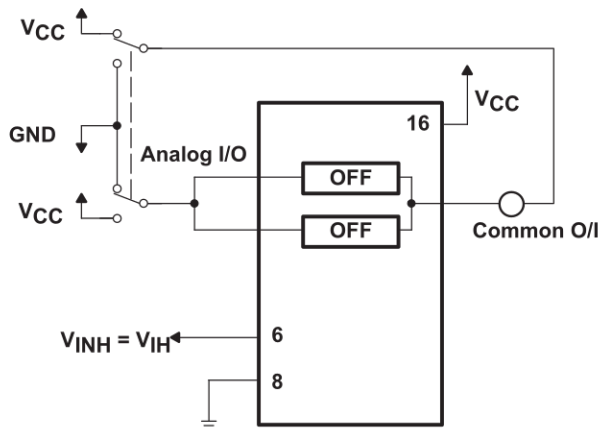

Figure 6-3. Maximum Off-Channel Leakage Current, Common Channel, Test Setup

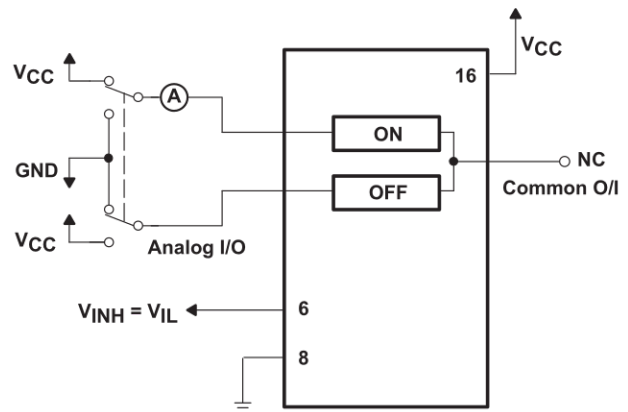

Figure 6-4. Maximum On-Channel Leakage Current, Channel To Channel, Test Setup

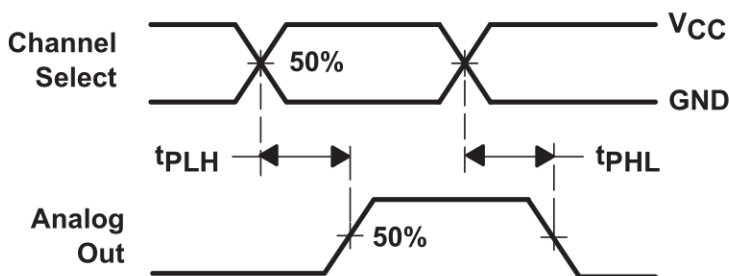
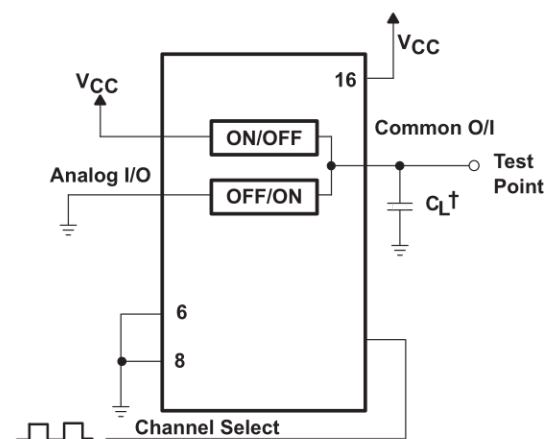

Figure 6-5. Propagation Delays, Channel Select to Analog Out



† Includes all probe and jig capacitance

Figure 6-6. Propagation-Delay Test Setup, Channel Select to Analog Out

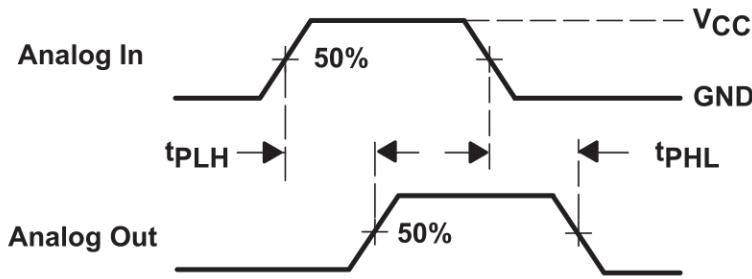
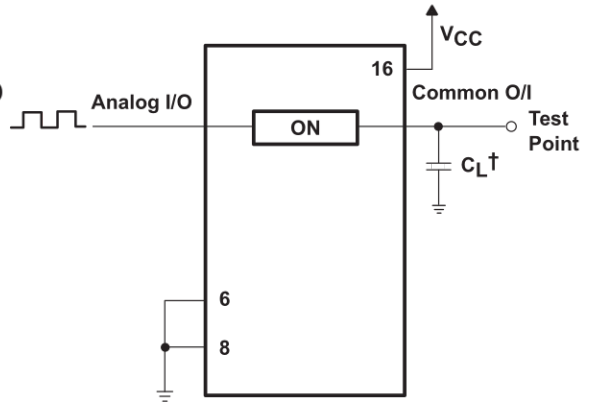

Figure 6-7. Propagation Delays, Analog In to Analog Out



† Includes all probe and jig capacitance

Figure 6-8. Propagation-Delay Test Setup, Analog In to Analog Out

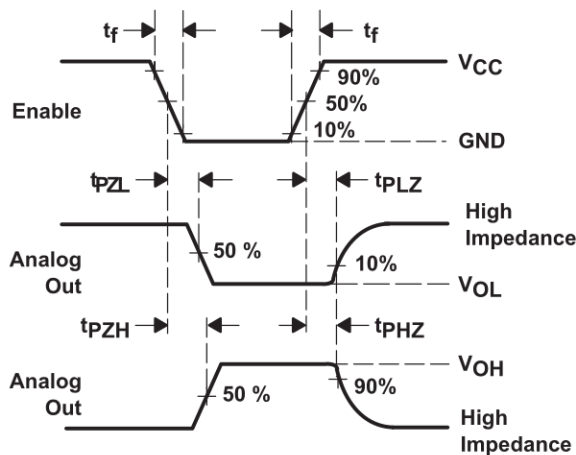

Figure 6-9. Propagation Delays, Enable to Analog Out

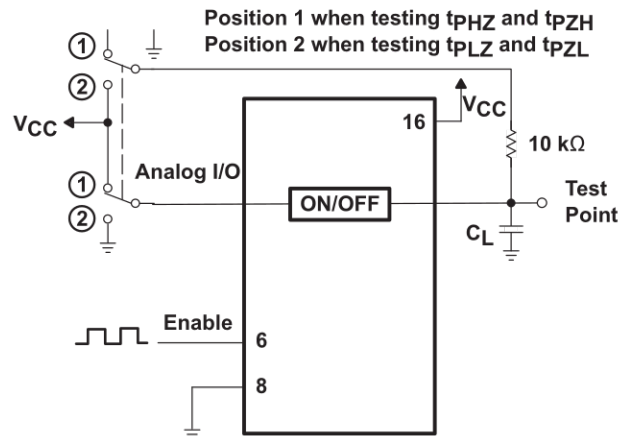

Figure 6-10. Propagation-Delay Test Setup, Enable to Analog Out

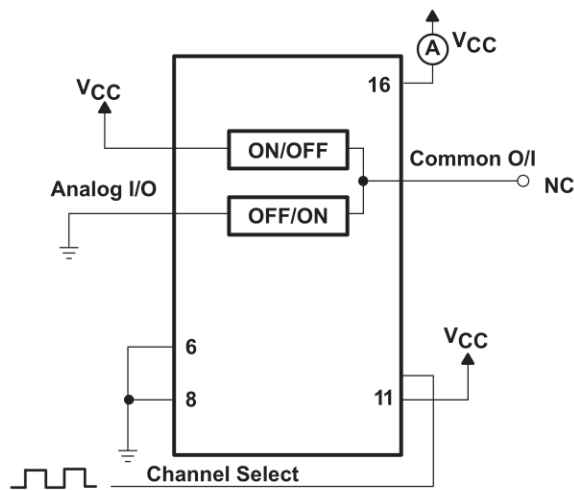

Figure 6-11. Power-Dissipation Capacitance Test Setup



## 7 Detailed Description

### 7.1 Functional Block Diagram

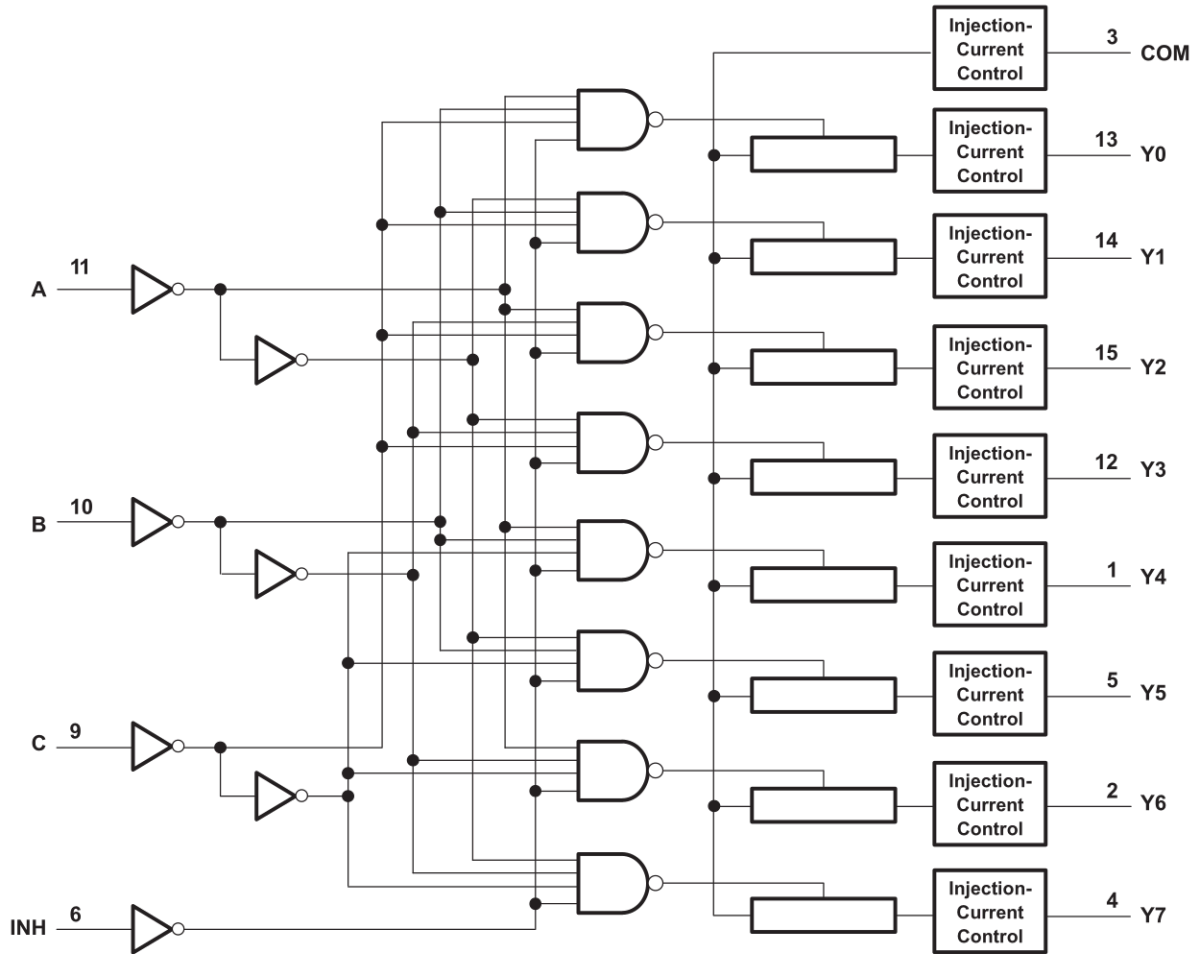

Figure 7-1. Logic Diagram (Positive Logic)

## 8 Application and Implementation

### Note

Information in the following applications sections is not part of the TI component specification, and TI does not warrant its accuracy or completeness. TI's customers are responsible for determining suitability of components for their purposes, as well as validating and testing their design implementation to confirm system functionality.

### 8.1 Application Information

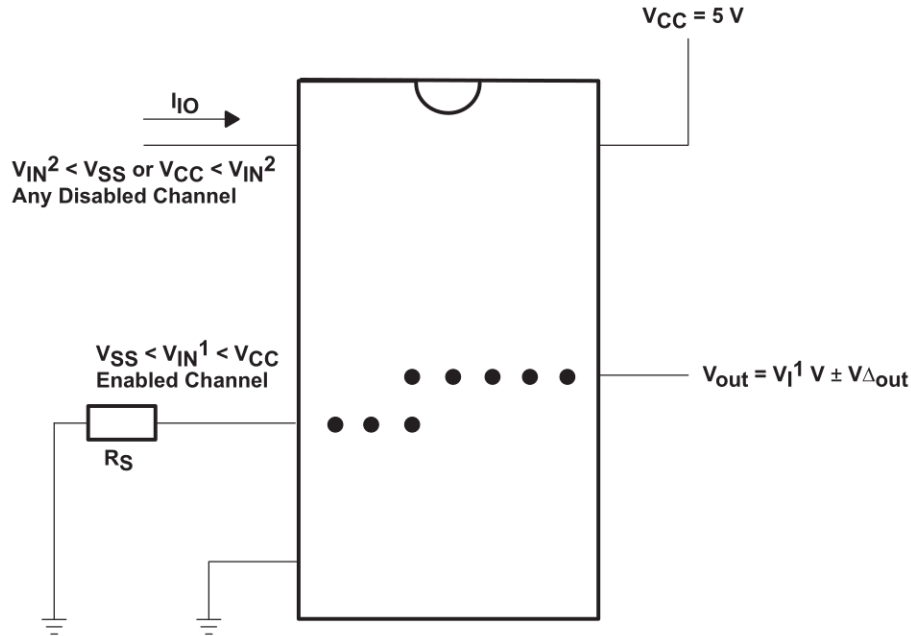

Figure 8-1. Injection-Current Coupling Specification

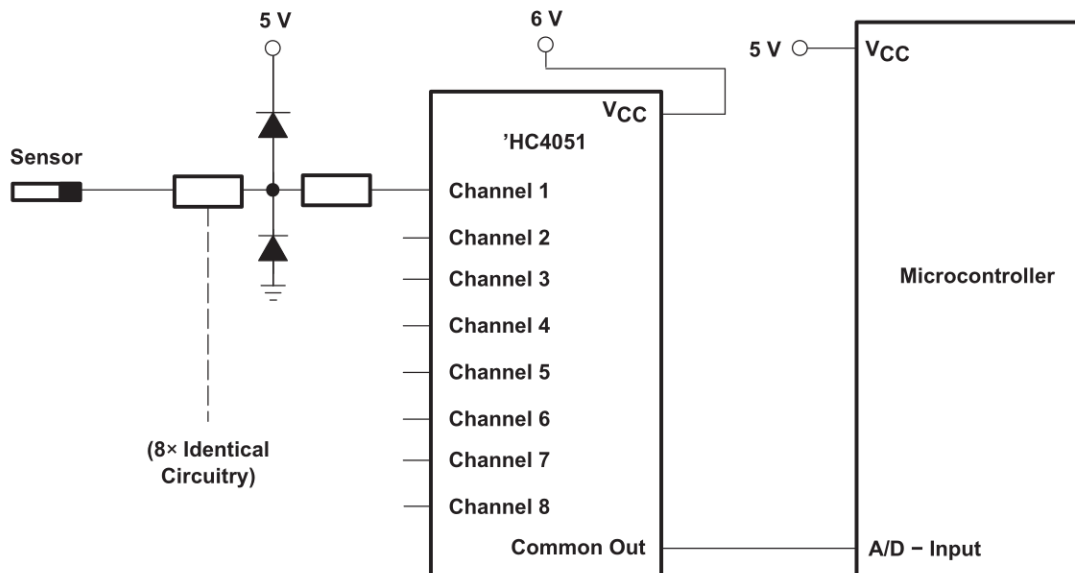

Figure 8-2. Alternate Solution Requires 32 Passive Components and One Extra 6-V Regulator to Suppress Injection Current Into a Standard 'HC4051 Multiplexer

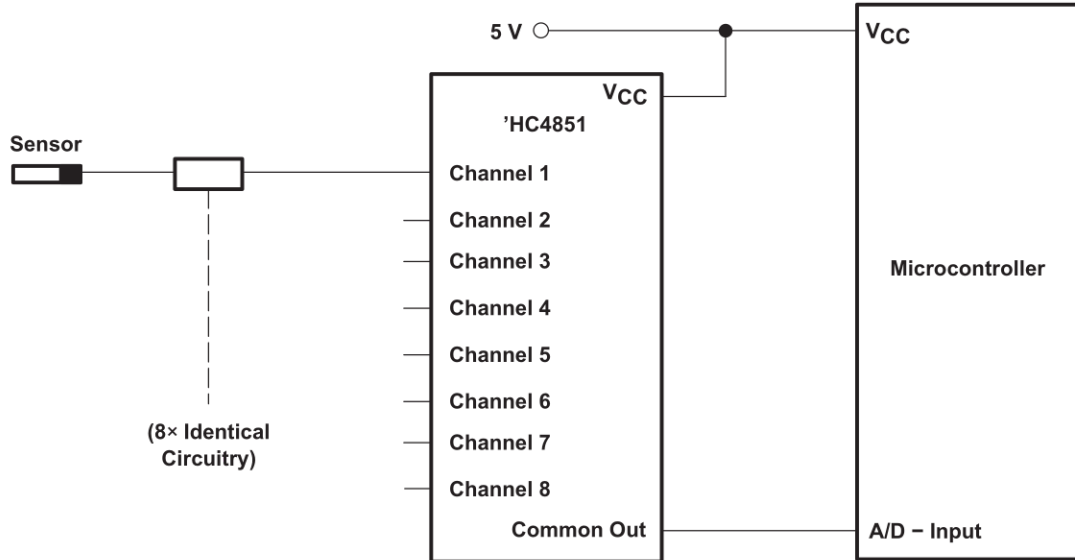

Figure 8-3. Solution by Applying the 'HC4851 Multiplexer

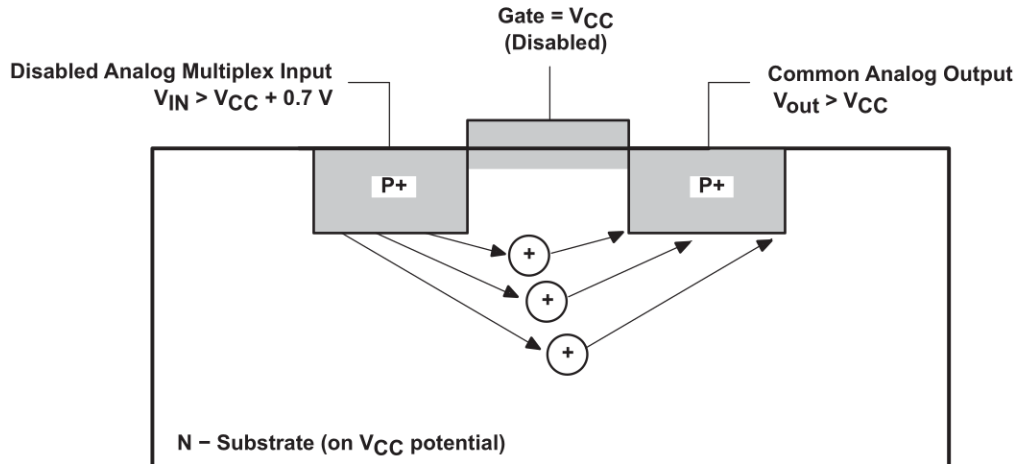

Figure 8-4. Diagram of Bipolar Coupling Mechanism (Appears if  $V_{IN}$  Exceeds  $V_{CC}$ , Driving Injection Current Into the Substrate)

## 9 Device and Documentation Support

TI offers an extensive line of development tools. Tools and software to evaluate the performance of the device, generate code, and develop solutions are listed below.

### 9.1 Receiving Notification of Documentation Updates

To receive notification of documentation updates, navigate to the device product folder on [ti.com](http://ti.com). Click on *Notifications* to register and receive a weekly digest of any product information that has changed. For change details, review the revision history included in any revised document.

### 9.2 Support Resources

TI E2E™ [support forums](#) are an engineer's go-to source for fast, verified answers and design help — straight from the experts. Search existing answers or ask your own question to get the quick design help you need.

Linked content is provided "AS IS" by the respective contributors. They do not constitute TI specifications and do not necessarily reflect TI's views; see TI's [Terms of Use](#).

### 9.3 Trademarks

TI E2E™ is a trademark of Texas Instruments.

All trademarks are the property of their respective owners.

### 9.4 Electrostatic Discharge Caution



This integrated circuit can be damaged by ESD. Texas Instruments recommends that all integrated circuits be handled with appropriate precautions. Failure to observe proper handling and installation procedures can cause damage.

ESD damage can range from subtle performance degradation to complete device failure. Precision integrated circuits may be more susceptible to damage because very small parametric changes could cause the device not to meet its published specifications.

### 9.5 Glossary

[TI Glossary](#) This glossary lists and explains terms, acronyms, and definitions.

## 10 Revision History

NOTE: Page numbers for previous revisions may differ from page numbers in the current version.

Changes from Revision B (January 2004) to Revision C (June 2024)	Page
• Updated the numbering format for tables, figures, and cross-references throughout the document.....	1
• Changed VCC ABS Max from 7V to 6V.....	3
• Changed R0JA.....	3
• Recommended supply changed from 6V to 5.5V and all test conditions using 6V were removed.....	4
• Changed ttran, tON, tOFF parameters.....	6
• Added Mechanical, Packaging, and Orderable Information section.....	12

## 11 Mechanical, Packaging, and Orderable Information

The following pages include mechanical packaging and orderable information. This information is the most current data available for the designated devices. This data is subject to change without notice and revision of this document. For browser based versions of this data sheet, refer to the left hand navigation.

## PACKAGING INFORMATION

Orderable Device	Status (1)	Package Type	Package Drawing	Pins	Package Qty	Eco Plan (2)	Lead finish/ Ball material (6)	MSL Peak Temp (3)	Op Temp (°C)	Device Marking (4/5)	Samples
SN74HC4851D	NRND	SOIC	D	16	40	RoHS & Green	NIPDAU	Level-1-260C-UNLIM	-40 to 125	HC4851	
SN74HC4851DGVR	NRND	TVSOP	DGV	16	2000	RoHS & Green	NIPDAU	Level-1-260C-UNLIM	-40 to 125	HC4851	
SN74HC4851DR	NRND	SOIC	D	16	2500	RoHS & Green	NIPDAU   SN	Level-1-260C-UNLIM	-40 to 125	HC4851	
SN74HC4851DRG4	NRND	SOIC	D	16	2500	RoHS & Green	NIPDAU	Level-1-260C-UNLIM	-40 to 125	HC4851	
SN74HC4851N	NRND	PDIP	N	16	25	RoHS & Green	NIPDAU	N / A for Pkg Type	-40 to 125	SN74HC4851N	
SN74HC4851PW	ACTIVE	TSSOP	PW	16	90	RoHS & Green	NIPDAU	Level-1-260C-UNLIM	-40 to 125	HC4851	Samples
SN74HC4851PWR	ACTIVE	TSSOP	PW	16	2000	RoHS & Green	NIPDAU	Level-1-260C-UNLIM	-40 to 125	HC4851	Samples
SN74HC4851PWRG4	ACTIVE	TSSOP	PW	16	2000	RoHS & Green	NIPDAU	Level-1-260C-UNLIM	-40 to 125	HC4851	Samples

(1) The marketing status values are defined as follows:

**ACTIVE:** Product device recommended for new designs.

**LIFEBUY:** TI has announced that the device will be discontinued, and a lifetime-buy period is in effect.

**NRND:** Not recommended for new designs. Device is in production to support existing customers, but TI does not recommend using this part in a new design.

**PREVIEW:** Device has been announced but is not in production. Samples may or may not be available.

**OBSELETE:** TI has discontinued the production of the device.

(2) **RoHS:** TI defines "RoHS" to mean semiconductor products that are compliant with the current EU RoHS requirements for all 10 RoHS substances, including the requirement that RoHS substance do not exceed 0.1% by weight in homogeneous materials. Where designed to be soldered at high temperatures, "RoHS" products are suitable for use in specified lead-free processes. TI may reference these types of products as "Pb-Free".

**RoHS Exempt:** TI defines "RoHS Exempt" to mean products that contain lead but are compliant with EU RoHS pursuant to a specific EU RoHS exemption.

**Green:** TI defines "Green" to mean the content of Chlorine (Cl) and Bromine (Br) based flame retardants meet JS709B low halogen requirements of <=1000ppm threshold. Antimony trioxide based flame retardants must also meet the <=1000ppm threshold requirement.

(3) MSL, Peak Temp. - The Moisture Sensitivity Level rating according to the JEDEC industry standard classifications, and peak solder temperature.

(4) There may be additional marking, which relates to the logo, the lot trace code information, or the environmental category on the device.

(5) Multiple Device Markings will be inside parentheses. Only one Device Marking contained in parentheses and separated by a "~" will appear on a device. If a line is indented then it is a continuation of the previous line and the two combined represent the entire Device Marking for that device.

(6) Lead finish/Ball material - Orderable Devices may have multiple material finish options. Finish options are separated by a vertical ruled line. Lead finish/Ball material values may wrap to two lines if the finish value exceeds the maximum column width.

**Important Information and Disclaimer:** The information provided on this page represents TI's knowledge and belief as of the date that it is provided. TI bases its knowledge and belief on information provided by third parties, and makes no representation or warranty as to the accuracy of such information. Efforts are underway to better integrate information from third parties. TI has taken and continues to take reasonable steps to provide representative and accurate information but may not have conducted destructive testing or chemical analysis on incoming materials and chemicals. TI and TI suppliers consider certain information to be proprietary, and thus CAS numbers and other limited information may not be available for release.

In no event shall TI's liability arising out of such information exceed the total purchase price of the TI part(s) at issue in this document sold by TI to Customer on an annual basis.

**OTHER QUALIFIED VERSIONS OF SN74HC4851 :**

- Automotive : [SN74HC4851-Q1](#)

NOTE: Qualified Version Definitions:

- Automotive - Q100 devices qualified for high-reliability automotive applications targeting zero defects

## TAPE AND REEL INFORMATION

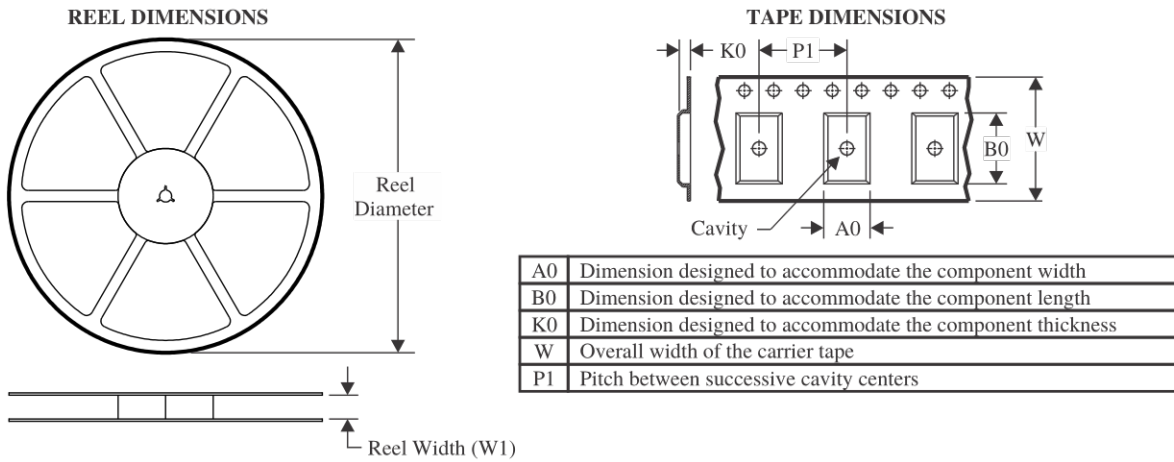

### QUADRANT ASSIGNMENTS FOR PIN 1 ORIENTATION IN TAPE

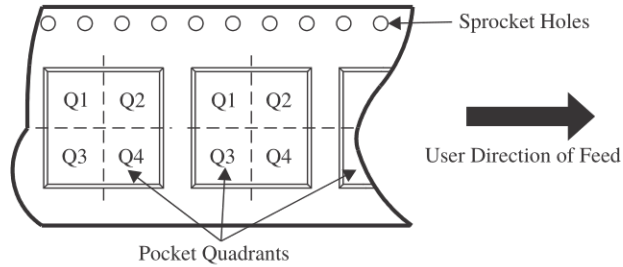

\*All dimensions are nominal

Device	Package Type	Package Drawing	Pins	SPQ	Reel Diameter (mm)	Reel Width W1 (mm)	A0 (mm)	B0 (mm)	K0 (mm)	P1 (mm)	W (mm)	Pin1 Quadrant
SN74HC4851DGVR	TVSOP	DGV	16	2000	330.0	12.4	6.8	4.0	1.6	8.0	12.0	Q1
SN74HC4851DR	SOIC	D	16	2500	330.0	16.4	6.5	10.3	2.1	8.0	16.0	Q1
SN74HC4851DRG4	SOIC	D	16	2500	330.0	16.4	6.5	10.3	2.1	8.0	16.0	Q1
SN74HC4851PWR	TSSOP	PW	16	2000	330.0	12.4	6.9	5.6	1.6	8.0	12.0	Q1
SN74HC4851PWR	TSSOP	PW	16	2000	330.0	12.4	6.9	5.6	1.6	8.0	12.0	Q1
SN74HC4851PWRG4	TSSOP	PW	16	2000	330.0	12.4	6.9	5.6	1.6	8.0	12.0	Q1

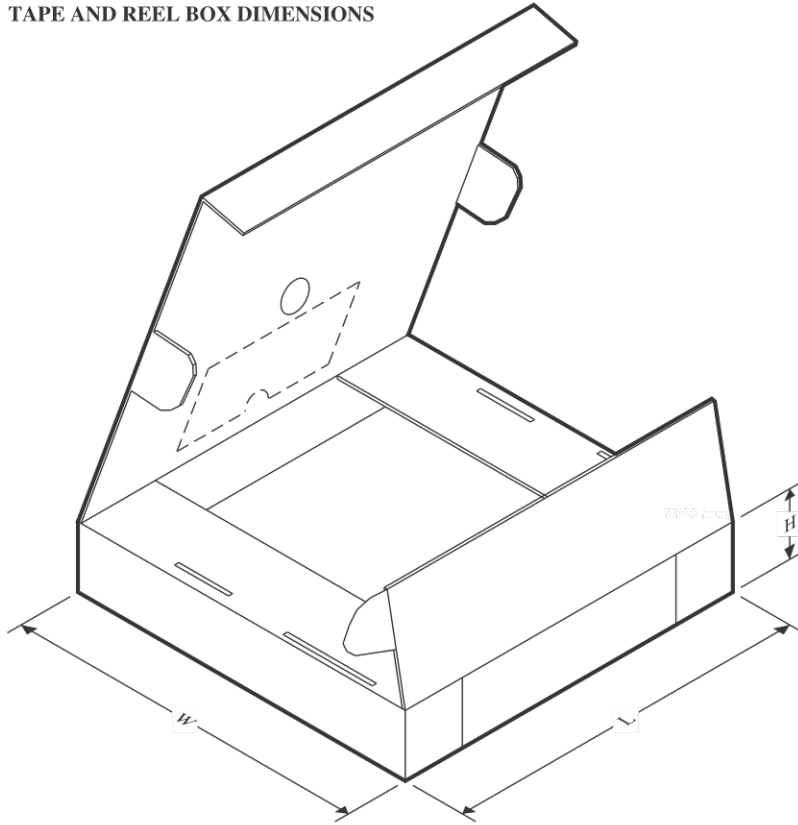
**TAPE AND REEL BOX DIMENSIONS**

\*All dimensions are nominal

Device	Package Type	Package Drawing	Pins	SPQ	Length (mm)	Width (mm)	Height (mm)
SN74HC4851DGVR	TVSOP	DGV	16	2000	356.0	356.0	35.0
SN74HC4851DR	SOIC	D	16	2500	353.0	353.0	32.0
SN74HC4851DRG4	SOIC	D	16	2500	353.0	353.0	32.0
SN74HC4851PWR	TSSOP	PW	16	2000	356.0	356.0	35.0
SN74HC4851PWR	TSSOP	PW	16	2000	210.0	185.0	35.0
SN74HC4851PWRG4	TSSOP	PW	16	2000	356.0	356.0	35.0

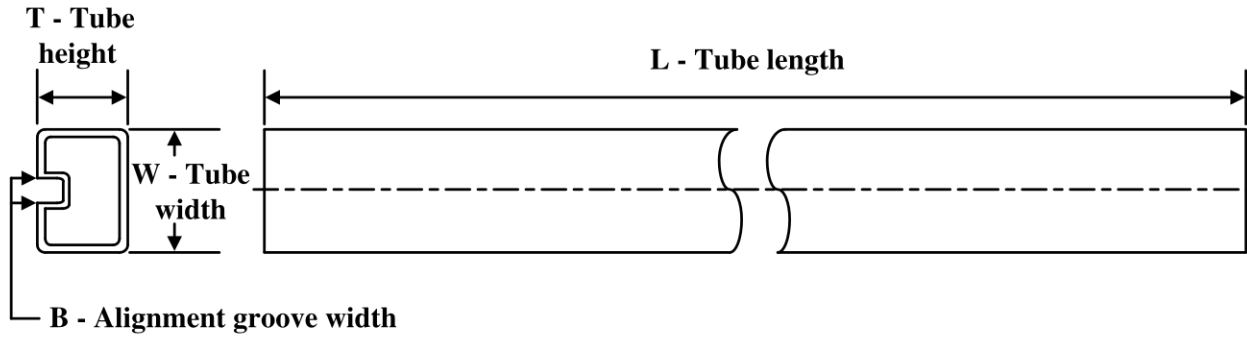

**TUBE**

\*All dimensions are nominal

Device	Package Name	Package Type	Pins	SPQ	L (mm)	W (mm)	T (μm)	B (mm)
SN74HC4851D	D	SOIC	16	40	507	8	3940	4.32
SN74HC4851N	N	PDIP	16	25	506	13.97	11230	4.32
SN74HC4851PW	PW	TSSOP	16	90	530	10.2	3600	3.5

D (R-PDSO-G16)

PLASTIC SMALL OUTLINE

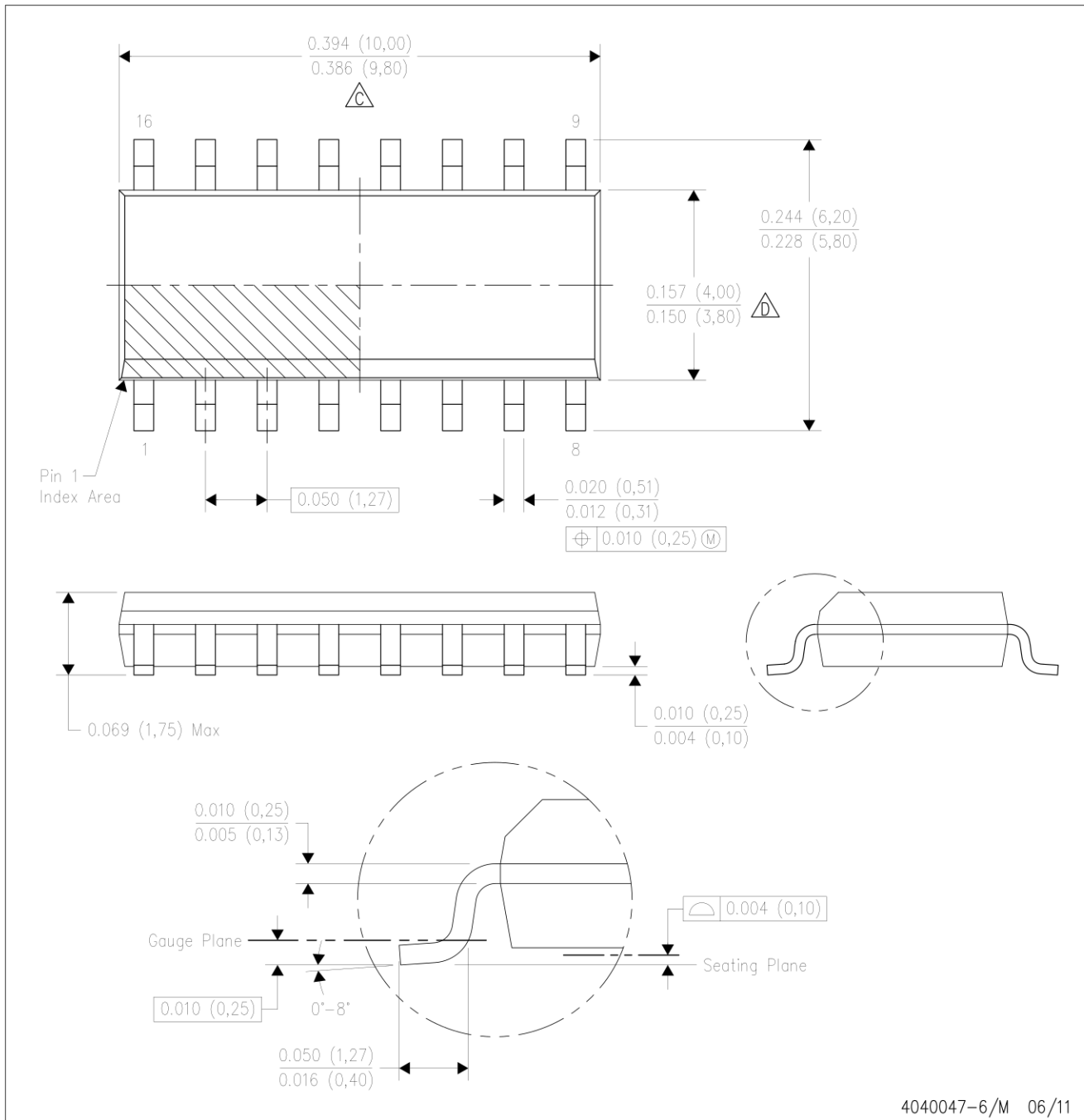

- NOTES:
- A. All linear dimensions are in inches (millimeters).
  - B. This drawing is subject to change without notice.
  - C. Body length does not include mold flash, protrusions, or gate burrs. Mold flash, protrusions, or gate burrs shall not exceed 0.006 (0,15) each side.
  - D. Body width does not include interlead flash. Interlead flash shall not exceed 0.017 (0,43) each side.
  - E. Reference JEDEC MS-012 variation AC.

# PW0016A

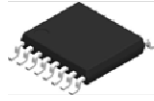

# PACKAGE OUTLINE

## TSSOP - 1.2 mm max height

SMALL OUTLINE PACKAGE

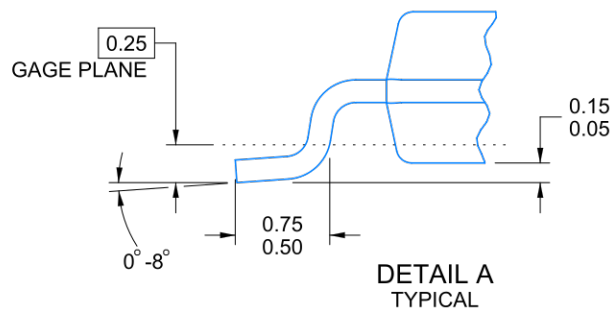
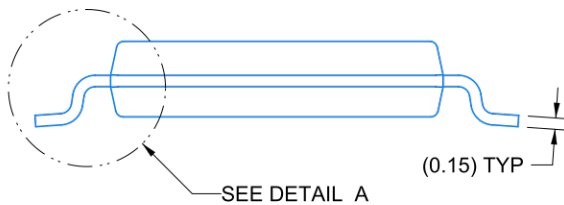
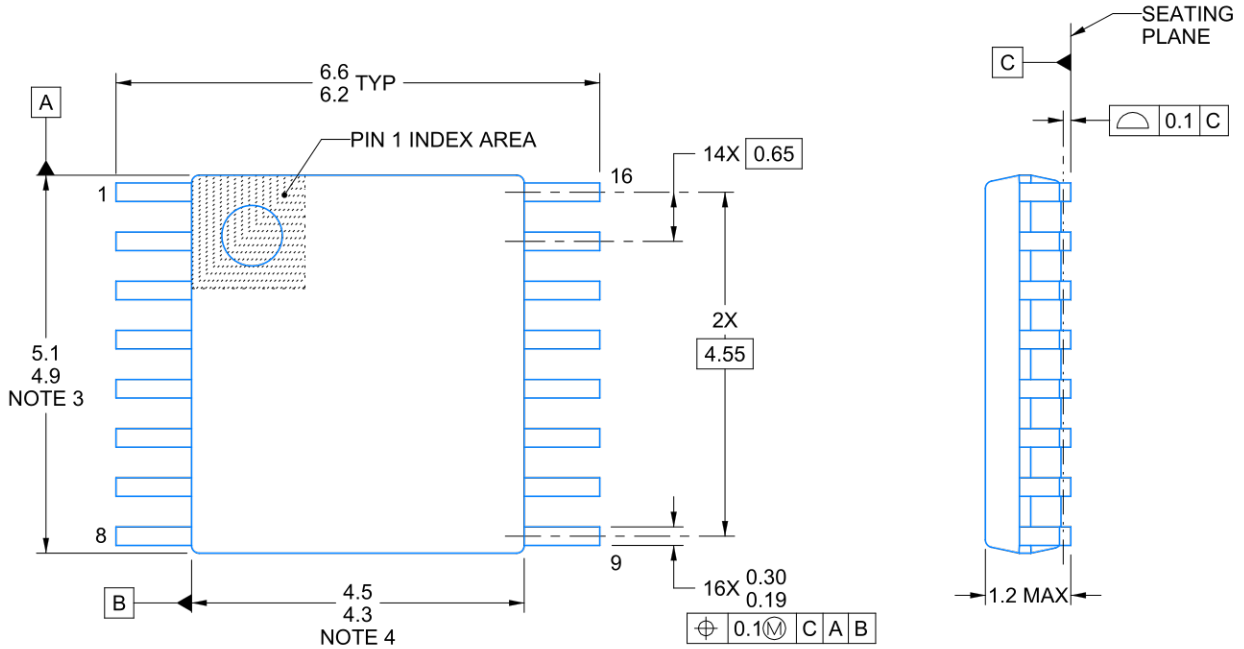

4220204/A 02/2017

### NOTES:

1. All linear dimensions are in millimeters. Any dimensions in parenthesis are for reference only. Dimensioning and tolerancing per ASME Y14.5M.
2. This drawing is subject to change without notice.
3. This dimension does not include mold flash, protrusions, or gate burrs. Mold flash, protrusions, or gate burrs shall not exceed 0.15 mm per side.
4. This dimension does not include interlead flash. Interlead flash shall not exceed 0.25 mm per side.
5. Reference JEDEC registration MO-153.

# EXAMPLE BOARD LAYOUT

PW0016A

TSSOP - 1.2 mm max height

SMALL OUTLINE PACKAGE

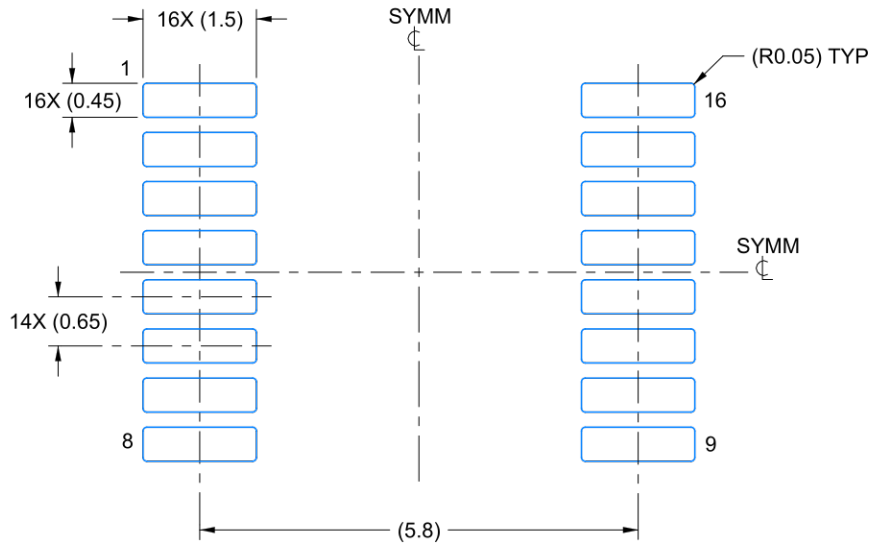

LAND PATTERN EXAMPLE  
EXPOSED METAL SHOWN  
SCALE: 10X

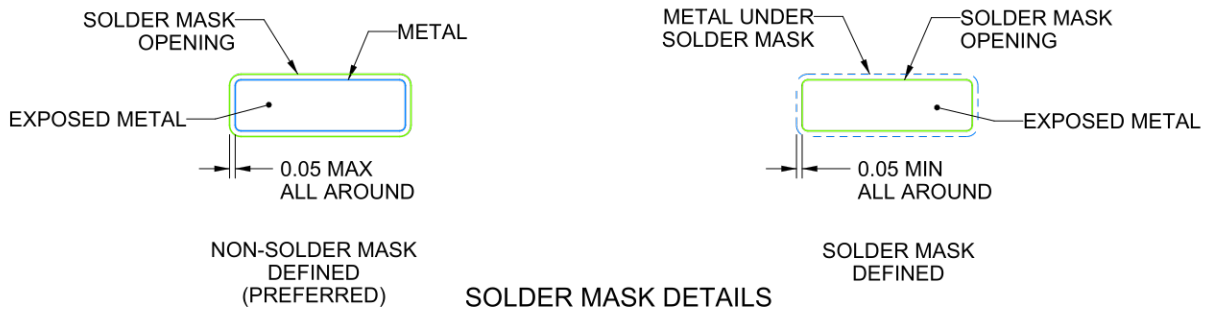

SOLDER MASK DETAILS

4220204/A 02/2017

NOTES: (continued)

- 6. Publication IPC-7351 may have alternate designs.
- 7. Solder mask tolerances between and around signal pads can vary based on board fabrication site.

# EXAMPLE STENCIL DESIGN

PW0016A

TSSOP - 1.2 mm max height

SMALL OUTLINE PACKAGE

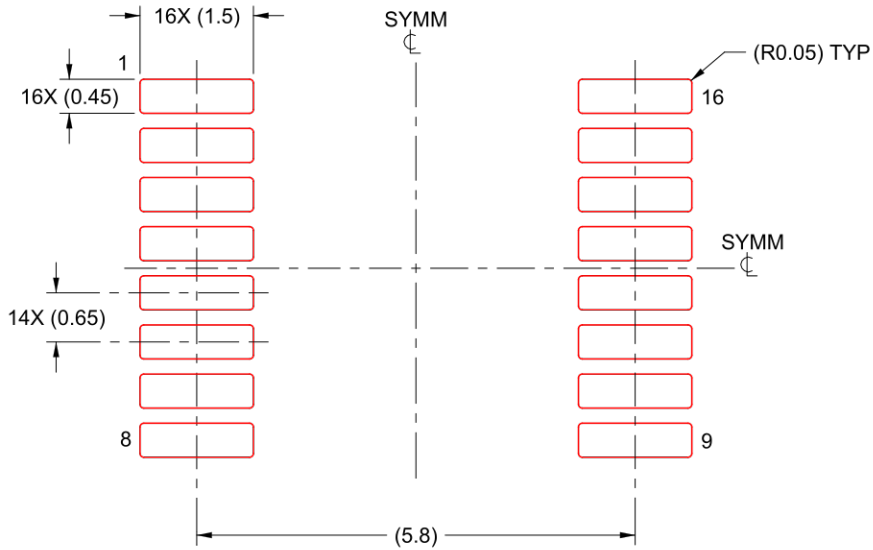

SOLDER PASTE EXAMPLE  
BASED ON 0.125 mm THICK STENCIL  
SCALE: 10X

4220204/A 02/2017

NOTES: (continued)

8. Laser cutting apertures with trapezoidal walls and rounded corners may offer better paste release. IPC-7525 may have alternate design recommendations.
9. Board assembly site may have different recommendations for stencil design.

DGV (R-PDSO-G\*\*)

PLASTIC SMALL-OUTLINE

24 PINS SHOWN

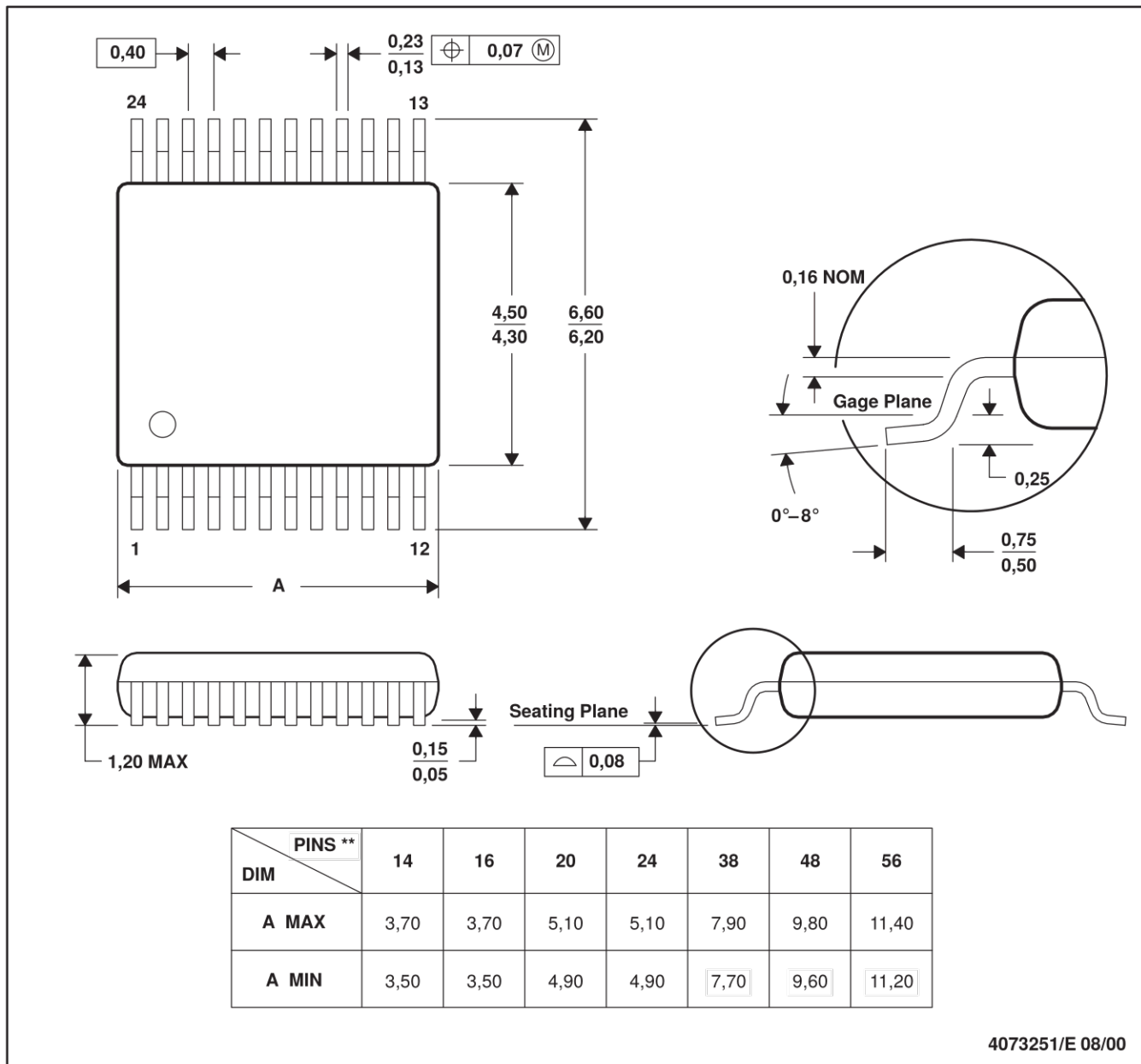

- NOTES: A. All linear dimensions are in millimeters.  
 B. This drawing is subject to change without notice.  
 C. Body dimensions do not include mold flash or protrusion, not to exceed 0,15 per side.  
 D. Falls within JEDEC: 24/48 Pins – MO-153  
 14/16/20/56 Pins – MO-194

N (R-PDIP-T\*\*)

PLASTIC DUAL-IN-LINE PACKAGE

16 PINS SHOWN

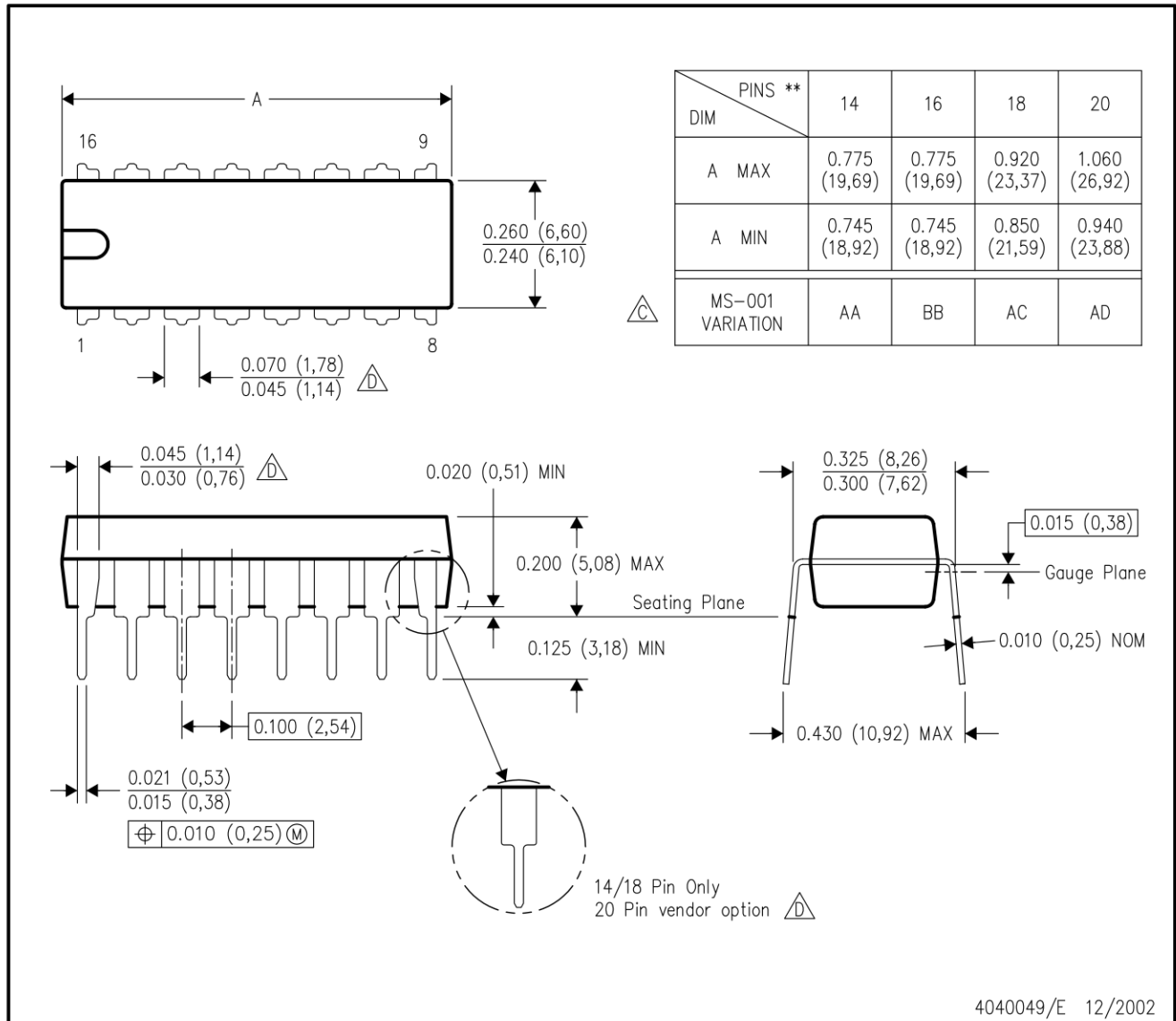

- NOTES:
- A. All linear dimensions are in inches (millimeters).
  - B. This drawing is subject to change without notice.
  - Falls within JEDEC MS-001, except 18 and 20 pin minimum body length (Dim A).
  - The 20 pin end lead shoulder width is a vendor option, either half or full width.

## IMPORTANT NOTICE AND DISCLAIMER

TI PROVIDES TECHNICAL AND RELIABILITY DATA (INCLUDING DATA SHEETS), DESIGN RESOURCES (INCLUDING REFERENCE DESIGNS), APPLICATION OR OTHER DESIGN ADVICE, WEB TOOLS, SAFETY INFORMATION, AND OTHER RESOURCES "AS IS" AND WITH ALL FAULTS, AND DISCLAIMS ALL WARRANTIES, EXPRESS AND IMPLIED, INCLUDING WITHOUT LIMITATION ANY IMPLIED WARRANTIES OF MERCHANTABILITY, FITNESS FOR A PARTICULAR PURPOSE OR NON-INFRINGEMENT OF THIRD PARTY INTELLECTUAL PROPERTY RIGHTS.

These resources are intended for skilled developers designing with TI products. You are solely responsible for (1) selecting the appropriate TI products for your application, (2) designing, validating and testing your application, and (3) ensuring your application meets applicable standards, and any other safety, security, regulatory or other requirements.

These resources are subject to change without notice. TI grants you permission to use these resources only for development of an application that uses the TI products described in the resource. Other reproduction and display of these resources is prohibited. No license is granted to any other TI intellectual property right or to any third party intellectual property right. TI disclaims responsibility for, and you will fully indemnify TI and its representatives against, any claims, damages, costs, losses, and liabilities arising out of your use of these resources.

TI's products are provided subject to [TI's Terms of Sale](#) or other applicable terms available either on [ti.com](https://www.ti.com) or provided in conjunction with such TI products. TI's provision of these resources does not expand or otherwise alter TI's applicable warranties or warranty disclaimers for TI products.

TI objects to and rejects any additional or different terms you may have proposed. [IMPORTANT NOTICE](#)

Mailing Address: Texas Instruments, Post Office Box 655303, Dallas, Texas 75265  
Copyright © 2024, Texas Instruments Incorporated