

SN74LVC4245A Octal Bus Transceiver and 3.3-V to 5-V Shifter With 3-State Outputs

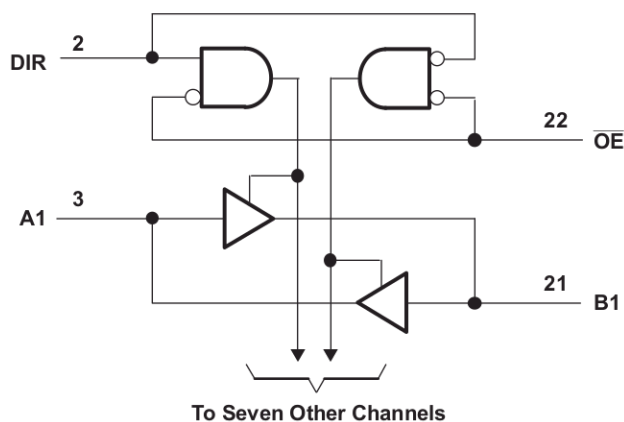
1 Features

- Bidirectional Voltage Translator
- 5.5 V on A Port and 2.7 V to 3.6 V on B Port
- Control Inputs V_{IH}/V_{IL} Levels Are Referenced to V_{CCA} Voltage
- Latch-Up Performance Exceeds 250 mA Per JESD 17
- ESD Protection Exceeds JESD 22
 - 2000-V Human-Body Model
 - 200-V Machine Model
 - 1000-V Charged-Device Model

2 Applications

- ATCA Solutions
- CPAP Machines
- Cameras: Surveillance Analog
- Chemical or Gas Sensors
- CT Scanners
- DLP 3D Machine Vision and Optical Networking
- Digital Signage
- ECGs: Electrocardiograms
- Field Transmitters: Pressure Sensors and Temperature Sensors
- High-Speed Data Acquisition and Generation
- HMI (Human Machine Interface)
- RF4CE Remote Controls
- Server Motherboards
- Software Defined Radios (SDR)
- Wireless LAN Cards and Data Access Cards
- X-ray: Medical, Dental, and Baggage Scanners

4 Simplified Schematic



3 Description

This 8-bit (octal) noninverting bus transceiver contains two separate supply rails; B port has V_{CCB} , which is set at 3.3 V, and A port has V_{CCA} , which is set at 5 V. This allows for translation from a 3.3-V to a 5-V environment, and vice versa.

The SN74LVC4245A device is designed for asynchronous communication between data buses. The device transmits data from the A bus to the B bus or from the B bus to the A bus, depending on the logic level at the direction-control (DIR) input. The output-enable (\overline{OE}) input can be used to disable the device so the buses are effectively isolated. The control circuitry (DIR, \overline{OE}) is powered by V_{CCA} .

The SN74LVC4245A device terminal out allows the designer to switch to a normal all-3.3-V or all-5-V 20-terminal SN74LVC4245 device without board re-layout. The designer uses the data paths for pins 2–11 and 14–23 of the SN74LVC4245A device to align with the conventional '245 terminal out.

Device Information⁽¹⁾

PART NUMBER	PACKAGE	BODY SIZE (NOM)
SN74LVC4245A	SSOP (24)	8.20 mm × 5.30 mm
	SOIC (24)	15.40 mm × 7.50 mm
	TSSOP (24)	7.80 mm × 4.40 mm

(1) For all available packages, see the orderable addendum at the end of the data sheet.



Table of Contents

1 Features	1	8.2 B Port	9
2 Applications	1	9 Detailed Description	10
3 Description	1	9.1 Overview	10
4 Simplified Schematic	1	9.2 Functional Block Diagram	10
5 Revision History	2	9.3 Feature Description	10
6 Pin Configuration and Functions	3	9.4 Device Functional Modes	10
7 Specifications	4	10 Application and Implementation	11
7.1 Absolute Maximum Ratings	4	10.1 Application Information	11
7.2 Absolute Maximum Ratings	4	10.2 Typical Application	11
7.3 ESD Ratings	4	11 Power Supply Recommendations	13
7.4 Recommended Operating Conditions	5	11.1 Power-Up Consideration	13
7.5 Recommended Operating Conditions	5	12 Layout	13
7.6 Thermal Information	5	12.1 Layout Guidelines	13
7.7 Electrical Characteristics	6	12.2 Layout Example	13
7.8 Electrical Characteristics	6	13 Device and Documentation Support	14
7.9 Switching Characteristics	7	13.1 Trademarks	14
7.10 Operating Characteristics	7	13.2 Electrostatic Discharge Caution	14
7.11 Typical Characteristics	7	13.3 Glossary	14
8 Parameter Measurement Information	8	14 Mechanical, Packaging, and Orderable Information	14
8.1 A Port	8		

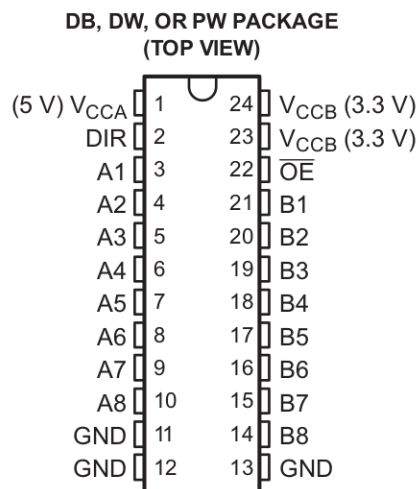
5 Revision History

Changes from Revision H (March 2005) to Revision I

Page

- Added *Applications*, *Device Information* table, *Pin Functions* table, *ESD Ratings* table, *Thermal Information* table, *Typical Characteristics*, *Feature Description* section, *Device Functional Modes*, *Application and Implementation* section, *Power Supply Recommendations* section, *Layout* section, *Device and Documentation Support* section, and *Mechanical, Packaging, and Orderable Information* section. **1**
- Deleted *Ordering Information* table. **1**

6 Pin Configuration and Functions



Pin Functions

PIN		TYPE	DESCRIPTION
NO.	NAME		
1	V_{CCA}	—	Power supply for side A
2	DIR	I	Direction control
3	A1	I/O	Transceiver I/O pin
4	A2	I/O	Transceiver I/O pin
5	A3	I/O	Transceiver I/O pin
6	A4	I/O	Transceiver I/O pin
7	A5	I/O	Transceiver I/O pin
8	A6	I/O	Transceiver I/O pin
9	A7	I/O	Transceiver I/O pin
10	A8	I/O	Transceiver I/O pin
11	GND	—	Ground
12	GND	—	Ground
13	GND	—	Ground
14	B8	I/O	Transceiver I/O pin
15	B7	I/O	Transceiver I/O pin
16	B6	I/O	Transceiver I/O pin
17	B5	I/O	Transceiver I/O pin
18	B4	I/O	Transceiver I/O pin
19	B3	I/O	Transceiver I/O pin
20	B2	I/O	Transceiver I/O pin
21	B1	I/O	Transceiver I/O pin
22	\overline{OE}	I	Output Enable
23	V_{CCB}	—	Power supply for side B
24	V_{CCB}	—	Power supply for side B

7 Specifications

7.1 Absolute Maximum Ratings

over operating free-air temperature range for $V_{CCA} = 4.5\text{ V to }5.5\text{ V}$ (unless otherwise noted)⁽¹⁾

		MIN	MAX	UNIT
V_{CCA}	Supply voltage range	-0.5	6.5	V
V_I	Input voltage range	A port ⁽²⁾	$V_{CCA} + 0.5$	V
		Control inputs	6	
V_O	Output voltage range	A port ⁽²⁾	$V_{CCA} + 0.5$	V
I_{IK}	Input clamp current	$V_I < 0$	-50	mA
I_{OK}	Output clamp current	$V_O < 0$	-50	mA
I_O	Continuous output current		±50	mA
	Continuous current through each V_{CCA} or GND		±100	mA
T_{stg}	Storage temperature range	-65	150	°C

- (1) Stresses beyond those listed under *Absolute Maximum Ratings* may cause permanent damage to the device. These are stress ratings only, and functional operation of the device at these or any other conditions beyond those indicated under *Recommended Operating Conditions* is not implied. Exposure to absolute-maximum-rated conditions for extended periods may affect device reliability.
- (2) This value is limited to 6 V maximum.

7.2 Absolute Maximum Ratings

over operating free-air temperature range for $V_{CCB} = 2.7\text{ V to }3.6\text{ V}$ (unless otherwise noted)⁽¹⁾

		MIN	MAX	UNIT
V_{CCB}	Supply voltage range	-0.5	4.6	V
V_I	Input voltage range	B port ⁽²⁾	$V_{CCB} + 0.5$	V
V_O	Output voltage range	B port ⁽²⁾	$V_{CCB} + 0.5$	V
I_{IK}	Input clamp current	$V_I < 0$	-50	mA
I_{OK}	Output clamp current	$V_O < 0$	-50	mA
I_O	Continuous output current		±50	mA
	Continuous current through V_{CCB} or GND		±100	mA
T_{stg}	Storage temperature range	-65	150	°C

- (1) Stresses beyond those listed under *Absolute Maximum Ratings* may cause permanent damage to the device. These are stress ratings only, and functional operation of the device at these or any other conditions beyond those indicated under *Recommended Operating Conditions* is not implied. Exposure to absolute-maximum-rated conditions for extended periods may affect device reliability.
- (2) This value is limited to 4.6 V maximum.

7.3 ESD Ratings

PARAMETER	DEFINITION	VALUE	UNIT
$V_{(ESD)}$	Electrostatic discharge	Human body model (HBM), per ANSI/ESDA/JEDEC JS-001, all pins ⁽¹⁾	2000
		Charged device model (CDM), per JEDEC specification JESD22-C101, all pins ⁽²⁾	1000

- (1) JEDEC document JEP155 states that 500-V HBM allows safe manufacturing with a standard ESD control process.
- (2) JEDEC document JEP157 states that 250-V CDM allows safe manufacturing with a standard ESD control process.

7.4 Recommended Operating Conditions

 for $V_{CCA} = 4.5\text{ V to }5.5\text{ V}^{(1)}$

		MIN	MAX	UNIT
V_{CCA}	Supply voltage	4.5	5.5	V
V_{IH}	High-level input voltage	2		V
V_{IL}	Low-level input voltage		0.8	V
V_{IA}	Input voltage	0	V_{CCA}	V
V_{OA}	Output voltage	0	V_{CCA}	V
I_{OH}	High-level output current		-24	mA
I_{OL}	Low-level output current		24	mA
T_A	Operating free-air temperature	-40	85	°C

(1) All unused inputs of the device must be held at the associated V_{CC} or GND to ensure proper device operation. Refer to the TI application report, *Implications of Slow or Floating CMOS Inputs*, literature number [SCBA004](#).

7.5 Recommended Operating Conditions

 for $V_{CCB} = 2.7\text{ V to }3.6\text{ V}^{(1)}$

			MIN	MAX	UNIT
V_{CCB}	Supply voltage		2.7	3.6	V
V_{IH}	High-level input voltage	$V_{CCB} = 2.7\text{ V to }3.6\text{ V}$	2		V
V_{IL}	Low-level input voltage	$V_{CCB} = 2.7\text{ V to }3.6\text{ V}$		0.8	V
V_{IB}	Input voltage		0	V_{CCB}	V
V_{OB}	Output voltage		0	V_{CCB}	V
I_{OH}	High-level output current	$V_{CCB} = 2.7\text{ V}$		-12	mA
		$V_{CCB} = 3\text{ V}$		-24	
I_{OL}	Low-level output current	$V_{CCB} = 2.7\text{ V}$		12	mA
		$V_{CCB} = 3\text{ V}$		24	
T_A	Operating free-air temperature		-40	85	°C

(1) All unused inputs of the device must be held at the associated V_{CC} or GND to ensure proper device operation. Refer to the TI application report, *Implications of Slow or Floating CMOS Inputs*, literature number [SCBA004](#).

7.6 Thermal Information

THERMAL METRIC ⁽¹⁾	SN74LVC4245A			UNIT	
	DB	DW	PW		
	24 PINS				
$R_{\theta JA}$	Junction-to-ambient thermal resistance	63	46	88	°C/W

(1) For more information about traditional and new thermal metrics, see the *IC Package Thermal Metrics* application report, [SPRA953](#).

7.7 Electrical Characteristics

 over recommended operating free-air temperature range for $V_{CCA} = 4.5\text{ V}$ to 5.5 V (unless otherwise noted)⁽¹⁾

PARAMETER		TEST CONDITIONS	V_{CCA}	MIN	TYP ⁽²⁾	MAX	UNIT
V_{OH}		$I_{OH} = -100\ \mu\text{A}$	4.5 V	4.3		V	
			5.5 V	5.3			
		$I_{OH} = -24\ \text{mA}$	4.5 V	3.7			
			5.5 V	4.7			
V_{OL}		$I_{OL} = 100\ \mu\text{A}$	4.5 V	0.2		V	
			5.5 V	0.2			
		$I_{OL} = 24\ \text{mA}$	4.5 V	0.55			
			5.5 V	0.55			
I_i	Control inputs	$V_i = V_{CCA}$ or GND	5.5 V	± 1		μA	
I_{OZ} ⁽³⁾	A port	$V_o = V_{CCA}$ or GND	5.5 V	± 5		μA	
I_{CCA}		$V_i = V_{CCA}$ or GND, $I_o = 0$	5.5 V	80		μA	
ΔI_{CCA} ⁽⁴⁾		One input at 3.4 V, Other inputs at V_{CCA} or GND	5.5 V	1.5		mA	
C_i	Control inputs	$V_i = V_{CCA}$ or GND	Open	5		pF	
C_{io}	A port	$V_o = V_{CCA}$ or GND	5 V	11		pF	

 (1) $V_{CCB} = 2.7\text{ V}$ to 3.6 V .

 (2) All typical values are measured at $V_{CC} = 5\text{ V}$, $T_A = 25^\circ\text{C}$.

 (3) For I/O ports, the parameter I_{OZ} includes the input leakage current.

 (4) This is the increase in supply current for each input that is at one of the specified TTL voltage levels, rather than 0 V or the associated V_{CC} .

7.8 Electrical Characteristics

 over recommended operating free-air temperature range for $V_{CCB} = 2.7\text{ V}$ to 3.6 V (unless otherwise noted)⁽¹⁾

PARAMETER		TEST CONDITIONS	V_{CCB}	MIN	TYP ⁽²⁾	MAX	UNIT
V_{OH}		$I_{OH} = -100\ \mu\text{A}$	2.7 V to 3.6 V	$V_{CC} - 0.2$		V	
			2.7 V	2.2			
		$I_{OH} = -24\ \text{mA}$	3 V	2.4			
			3 V	2			
V_{OL}		$I_{OL} = 100\ \mu\text{A}$	2.7 V to 3.6 V	0.2		V	
		$I_{OL} = 12\ \text{mA}$	2.7 V	0.4			
		$I_{OL} = 24\ \text{mA}$	3 V	0.55			
I_{OZ} ⁽³⁾	B port	$V_o = V_{CCB}$ or GND	3.6 V	± 5		μA	
I_{CCB}		$V_i = V_{CCB}$ or GND, $I_o = 0$	3.6 V	50		μA	
ΔI_{CCB} ⁽⁴⁾		One input at $V_{CCB} - 0.6\text{ V}$, Other inputs at V_{CCB} or GND	2.7 V to 3.6 V	0.5		mA	
C_{io}	B port	$V_o = V_{CCB}$ or GND	3.3 V	11		pF	

 (1) $V_{CCA} = 5\text{ V} \pm 0.5\text{ V}$.

 (2) All typical values are measured at $V_{CC} = 3.3\text{ V}$, $T_A = 25^\circ\text{C}$.

 (3) For I/O ports, the parameter I_{OZ} includes the input leakage current.

 (4) This is the increase in supply current for each input that is at one of the specified TTL voltage levels, rather than 0 V or the associated V_{CC} .

7.9 Switching Characteristics

over recommended operating free-air temperature range, $C_L = 50$ pF (unless otherwise noted) (see Figure 3 and Figure 4)

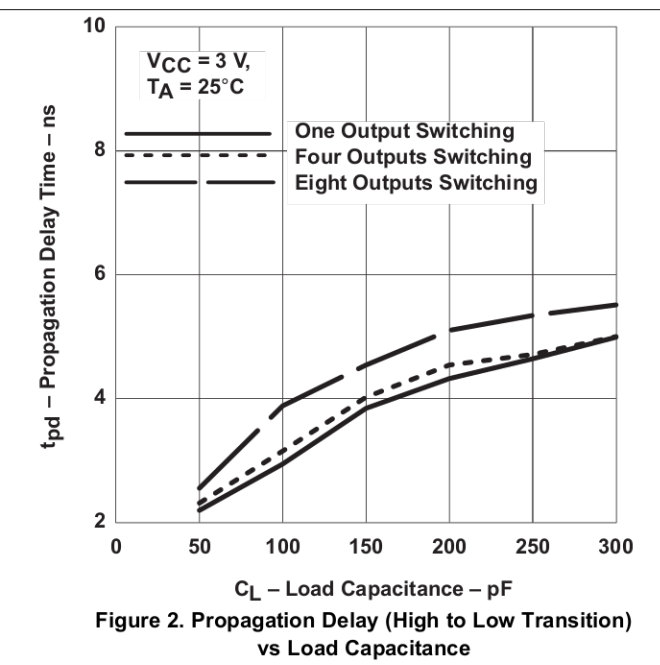
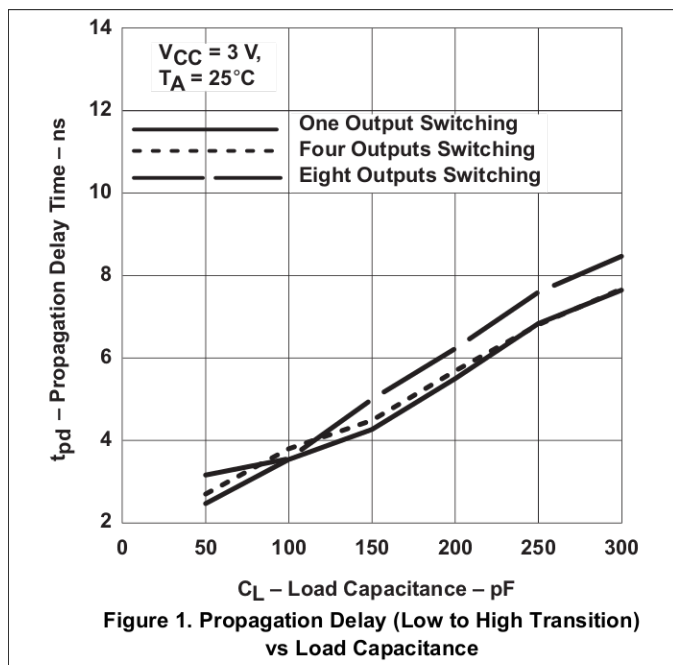
PARAMETER	FROM (INPUT)	TO (OUTPUT)	$V_{CCA} = 5 V \pm 0.5 V$, $V_{CCB} = 2.7 V$ to $3.6 V$		UNIT
			MIN	MAX	
t_{PHL}	A	B	1	6.3	ns
t_{PLH}			1	6.7	
t_{PHL}	B	A	1	6.1	ns
t_{PLH}			1	5	
t_{PZL}	\overline{OE}	A	1	9	ns
t_{PZH}			1	8.1	
t_{PZL}	\overline{OE}	B	1	8.8	ns
t_{PZH}			1	9.8	
t_{PLZ}	\overline{OE}	A	1	7	ns
t_{PHZ}			1	5.8	
t_{PLZ}	\overline{OE}	B	1	7.7	ns
t_{PHZ}			1	7.8	

7.10 Operating Characteristics

$V_{CCA} = 4.5 V$ to $5.5 V$, $V_{CCB} = 2.7 V$ to $3.6 V$, $T_A = 25^\circ C$

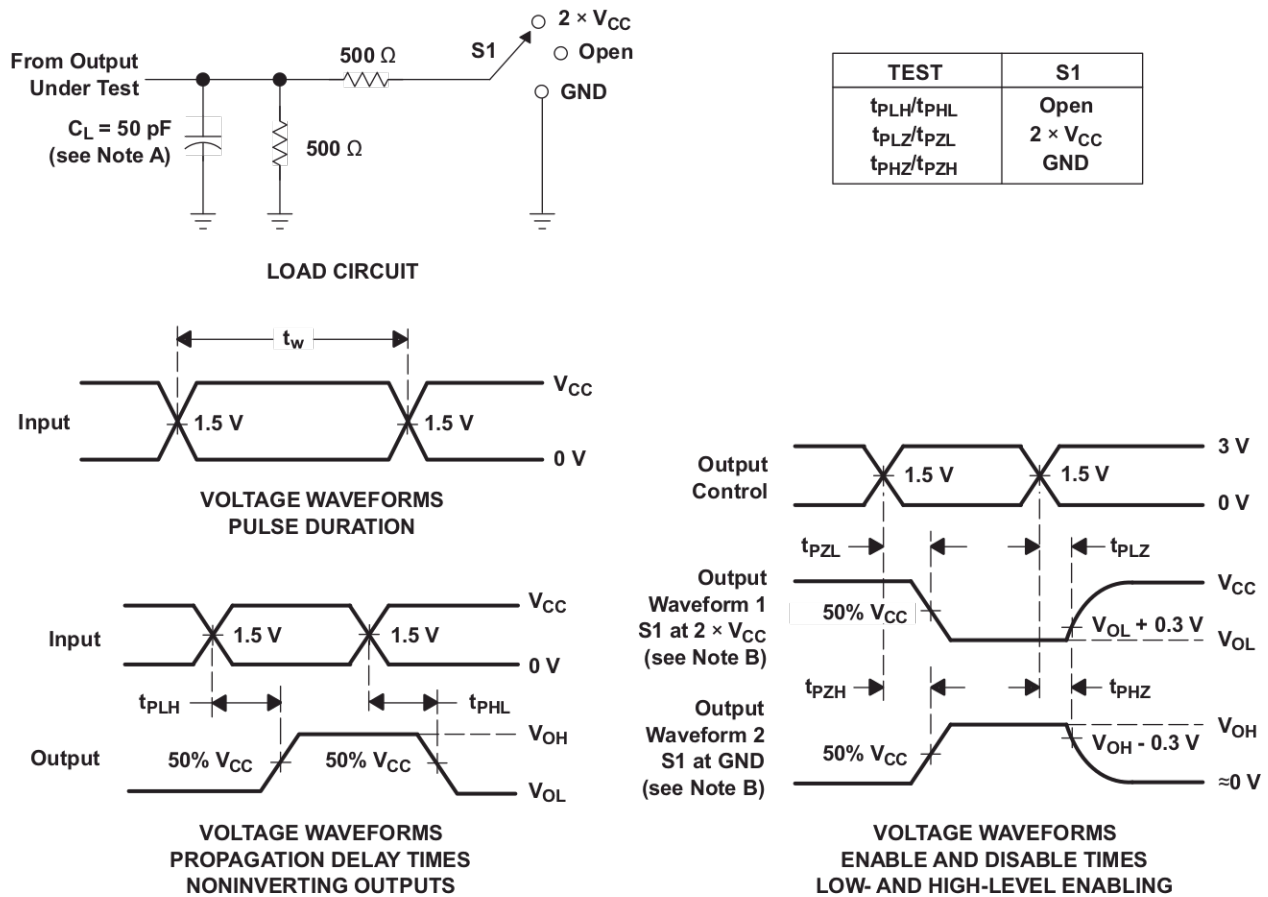
PARAMETER		TEST CONDITIONS		TYP	UNIT
C_{pd}	Power dissipation capacitance per transceiver	Outputs enabled	$C_L = 0$, $f = 10$ MHz	39.5	pF
		Outputs disabled		5	

7.11 Typical Characteristics



8 Parameter Measurement Information

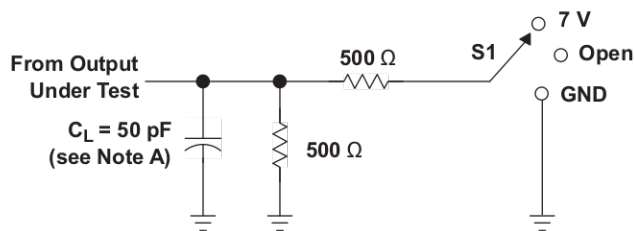
8.1 A Port



- NOTES:
- C_L includes probe and jig capacitance.
 - Waveform 1 is for an output with internal conditions such that the output is low, except when disabled by the output control. Waveform 2 is for an output with internal conditions such that the output is high, except when disabled by the output control.
 - All input pulses are supplied by generators having the following characteristics: $PRR \leq 10 \text{ MHz}$, $Z_O = 50 \Omega$, $t_r \leq 2.5 \text{ ns}$, $t_f \leq 2.5 \text{ ns}$.
 - The outputs are measured one at a time, with one transition per measurement.
 - All parameters and waveforms are not applicable to all devices.

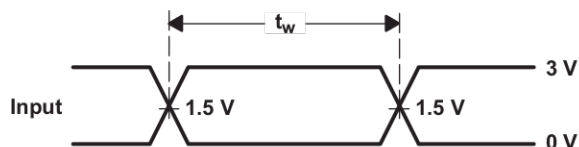
Figure 3. Load Circuit and Voltage Waveforms

8.2 B Port

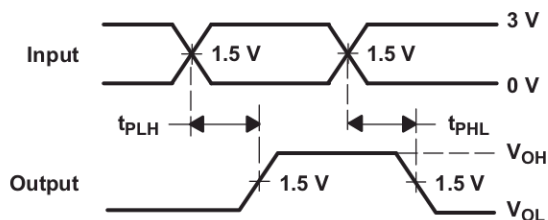


LOAD CIRCUIT

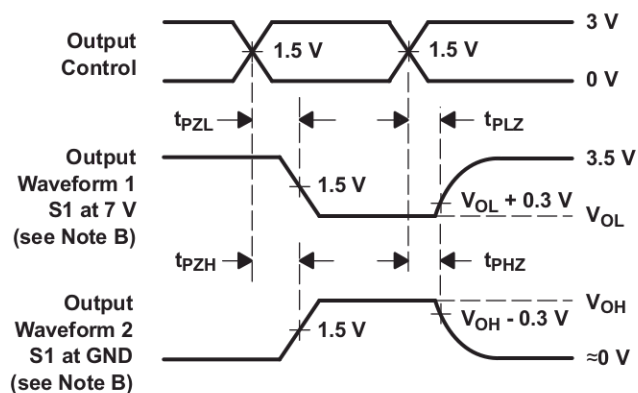
TEST	S1
t_{PLH}/t_{PHL}	Open
t_{PLZ}/t_{PZL}	7 V
t_{PHZ}/t_{PZH}	GND



VOLTAGE WAVEFORMS
PULSE DURATION



VOLTAGE WAVEFORMS
PROPAGATION DELAY TIMES
NONINVERTING OUTPUTS



VOLTAGE WAVEFORMS
ENABLE AND DISABLE TIMES
LOW- AND HIGH-LEVEL ENABLING

- NOTES: A. C_L includes probe and jig capacitance.
- B. Waveform 1 is for an output with internal conditions such that the output is low, except when disabled by the output control. Waveform 2 is for an output with internal conditions such that the output is high, except when disabled by the output control.
- C. All input pulses are supplied by generators having the following characteristics: $PRR \leq 10 \text{ MHz}$, $Z_O = 50 \Omega$, $t_r \leq 2.5 \text{ ns}$, $t_f \leq 2.5 \text{ ns}$.
- D. The outputs are measured one at a time, with one transition per measurement.
- E. All parameters and waveforms are not applicable to all devices.

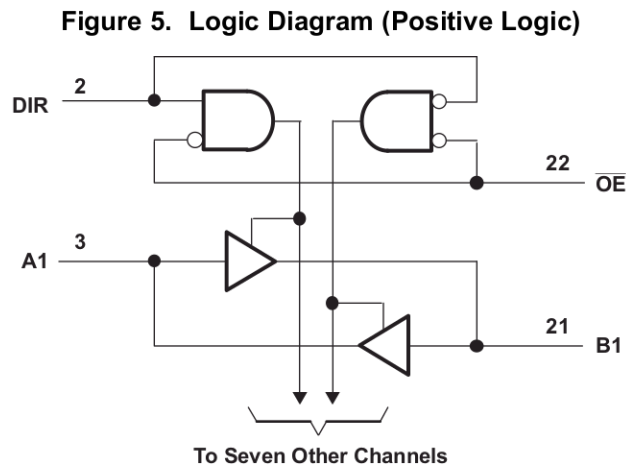
Figure 4. Load Circuit and Voltage Waveforms

9 Detailed Description

9.1 Overview

SN74LVC4245A is an 8-bit (octal) noninverting bus transceiver contains two separate supply rails; B port has V_{CCB} , which is set at 3.3 V, and A port has V_{CCA} , which is set at 5 V. This allows for translation from a 3.3-V to a 5-V environment, and vice versa, designed for asynchronous communication between data buses. The device transmits data from the A bus to the B bus or from the B bus to the A bus, depending on the logic level at the direction-control (DIR) input. The output-enable (\overline{OE}) input can be used to disable the device so the buses are effectively isolated. The control circuitry (DIR, \overline{OE}) is powered by V_{CCA} .

9.2 Functional Block Diagram



9.3 Feature Description

- 24 mA drive at 3-V supply
 - Good for heavier loads and longer traces
- Low V_{IH}
 - Allows 3.3-V to 5-V translation

9.4 Device Functional Modes

Function Table

INPUTS		OPERATION
\overline{OE}	DIR	
L	L	B data to A bus
L	H	A data to B bus
H	X	Isolation

10 Application and Implementation

10.1 Application Information

The SN74LVC4245A device pinout allows the designer to switch to a normal all-3.3-V or all-5-V 20-pin '245 device without board re-layout. The designer uses the data paths for pins 2–11 and 14–23 of the SN74LVC4245A to align with the conventional SN74LVC4245 device's pinout. SN74LVC4245A is a high drive CMOS device that can be used for a multitude of bus interface type applications where output drive or PCB trace length is a concern.

10.2 Typical Application

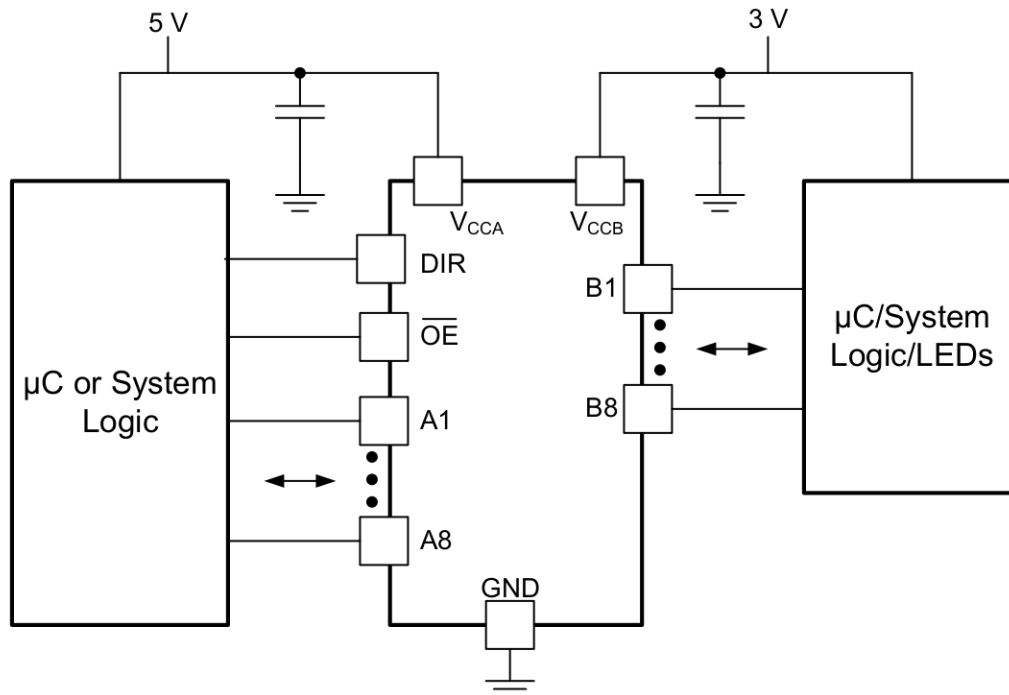


Figure 6. Typical Application Schematic

10.2.1 Design Requirements

This device uses CMOS technology and has balanced output drive. Care should be taken to avoid bus contention because it can drive currents that would exceed maximum limits. The high drive will also create fast edges into light loads so routing and load conditions should be considered to prevent ringing.

10.2.2 Detailed Design Procedure

1. Recommended Input Conditions:
 - For rise time and fall time specifications, see $(\Delta t/\Delta V)$ in the [Recommended Operating Conditions](#) table.
 - For specified high and low levels, see $(V_{IH}$ and $V_{IL})$ in the [Recommended Operating Conditions](#) table.
2. Recommend Output Conditions:
 - Load currents should not exceed $(I_O \text{ max})$ per output and should not exceed (Continuous current through V_{CC} or GND) total current for the part. These limits are located in the [Absolute Maximum Ratings](#) table.
 - Outputs should not be pulled above V_{CC} .
 - Series resistors on the output may be used if the user desires to slow the output edge signal or limit the output current.

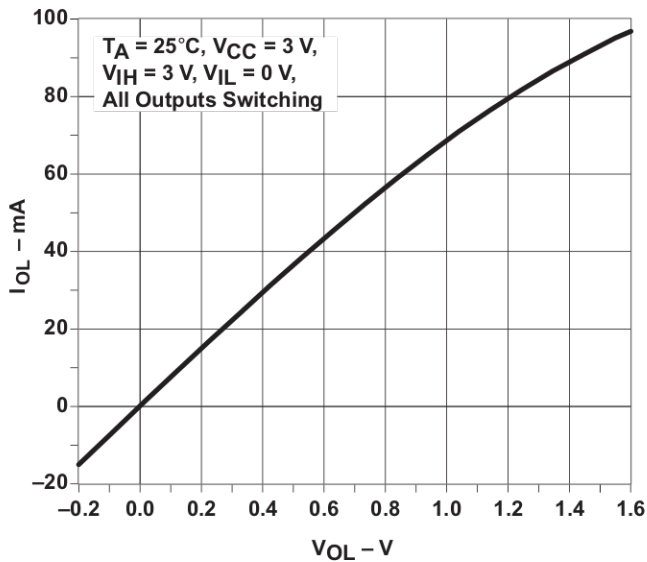
Typical Application (continued)
10.2.3 Application Curves


Figure 7. Output Drive Current (I_{OL}) vs LOW-level Output Voltage (V_{OL})

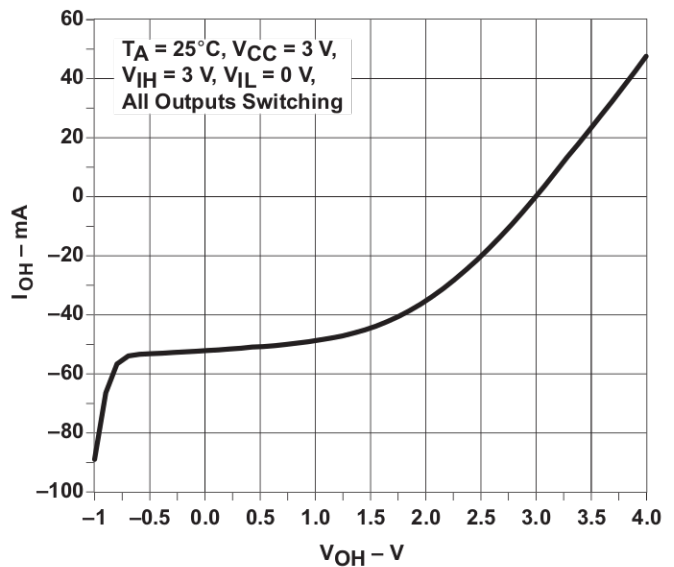


Figure 8. Output Drive Current (I_{OH}) vs HIGH-level Output Voltage (V_{OH})

11 Power Supply Recommendations

11.1 Power-Up Consideration

⁽¹⁾TI level-translation devices offer an opportunity for successful mixed-voltage signal design. A proper power-up sequence always should be followed to avoid excessive supply current, bus contention, oscillations, or other anomalies caused by improperly biased device terminals. Take these precautions to guard against such power-up problems:

1. Connect ground before any supply voltage is applied.
2. Power up the control side of the device (V_{CCA} for all four of these devices).
3. Tie \overline{OE} to V_{CCA} with a pullup resistor so that it ramps with V_{CCA} .
4. Depending on the direction of the data path, DIR can be high or low. If DIR high is needed (A data to B bus), ramp it with V_{CCA} . Otherwise, keep DIR low.

(1) Refer to the TI application report, *Texas Instruments Voltage-Level-Translation Devices*, literature number [SCEA021](#).

12 Layout

12.1 Layout Guidelines

When using multiple bit logic devices, inputs should not float. In many cases, functions or parts of functions of digital logic devices are unused. Some examples are when only two inputs of a triple-input AND gate are used, or when only 3 of the 4-buffer gates are used. Such input pins should not be left unconnected because the undefined voltages at the outside connections result in undefined operational states.

Specified in [Figure 9](#) are rules that must be observed under all circumstances. All unused inputs of digital logic devices must be connected to a high or low bias to prevent them from floating. The logic level that should be applied to any particular unused input depends on the function of the device. Generally they will be tied to GND or V_{CC} , whichever makes more sense or is more convenient.

12.2 Layout Example

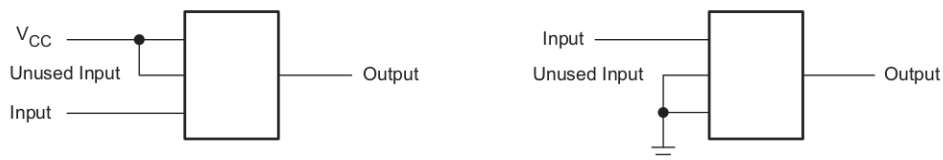


Figure 9. Layout Diagram

13 Device and Documentation Support

13.1 Trademarks

All trademarks are the property of their respective owners.

13.2 Electrostatic Discharge Caution



These devices have limited built-in ESD protection. The leads should be shorted together or the device placed in conductive foam during storage or handling to prevent electrostatic damage to the MOS gates.

13.3 Glossary

[SLYZ022](#) — *TI Glossary*.

This glossary lists and explains terms, acronyms, and definitions.

14 Mechanical, Packaging, and Orderable Information

The following pages include mechanical, packaging, and orderable information. This information is the most current data available for the designated devices. This data is subject to change without notice and revision of this document. For browser-based versions of this data sheet, refer to the left-hand navigation.

PACKAGING INFORMATION

Orderable Device	Status (1)	Package Type	Package Drawing	Pins	Package Qty	Eco Plan (2)	Lead finish/ Ball material (6)	MSL Peak Temp (3)	Op Temp (°C)	Device Marking (4/5)	Samples
SN74LVC4245ADBR	ACTIVE	SSOP	DB	24	2000	RoHS & Green	NIPDAU	Level-1-260C-UNLIM	-40 to 85	LJ245A	Samples
SN74LVC4245ADBRE4	ACTIVE	SSOP	DB	24	2000	RoHS & Green	NIPDAU	Level-1-260C-UNLIM	-40 to 85	LJ245A	Samples
SN74LVC4245ADW	ACTIVE	SOIC	DW	24	25	RoHS & Green	NIPDAU	Level-1-260C-UNLIM	-40 to 85	LVC4245A	Samples
SN74LVC4245ADWE4	ACTIVE	SOIC	DW	24	25	RoHS & Green	NIPDAU	Level-1-260C-UNLIM	-40 to 85	LVC4245A	Samples
SN74LVC4245ADWG4	ACTIVE	SOIC	DW	24	25	RoHS & Green	NIPDAU	Level-1-260C-UNLIM	-40 to 85	LVC4245A	Samples
SN74LVC4245ADWR	ACTIVE	SOIC	DW	24	2000	RoHS & Green	NIPDAU SN	Level-1-260C-UNLIM	-40 to 85	LVC4245A	Samples
SN74LVC4245ADWRE4	ACTIVE	SOIC	DW	24	2000	RoHS & Green	NIPDAU	Level-1-260C-UNLIM	-40 to 85	LVC4245A	Samples
SN74LVC4245ADWRG4	ACTIVE	SOIC	DW	24	2000	RoHS & Green	NIPDAU	Level-1-260C-UNLIM	-40 to 85	LVC4245A	Samples
SN74LVC4245APW	ACTIVE	TSSOP	PW	24	60	RoHS & Green	NIPDAU	Level-1-260C-UNLIM	-40 to 85	LJ245A	Samples
SN74LVC4245APWG4	ACTIVE	TSSOP	PW	24	60	RoHS & Green	NIPDAU	Level-1-260C-UNLIM	-40 to 85	LJ245A	Samples
SN74LVC4245APWR	ACTIVE	TSSOP	PW	24	2000	RoHS & Green	NIPDAU	Level-1-260C-UNLIM	-40 to 85	LJ245A	Samples
SN74LVC4245APWRE4	ACTIVE	TSSOP	PW	24	2000	RoHS & Green	NIPDAU	Level-1-260C-UNLIM	-40 to 85	LJ245A	Samples
SN74LVC4245APWRG4	ACTIVE	TSSOP	PW	24	2000	RoHS & Green	NIPDAU	Level-1-260C-UNLIM	-40 to 85	LJ245A	Samples
SN74LVC4245APWT	ACTIVE	TSSOP	PW	24	250	RoHS & Green	NIPDAU	Level-1-260C-UNLIM	-40 to 85	LJ245A	Samples
SN74LVC4245APWTG4	ACTIVE	TSSOP	PW	24	250	RoHS & Green	NIPDAU	Level-1-260C-UNLIM	-40 to 85	LJ245A	Samples

(1) The marketing status values are defined as follows:

ACTIVE: Product device recommended for new designs.

LIFEBUY: TI has announced that the device will be discontinued, and a lifetime-buy period is in effect.

NRND: Not recommended for new designs. Device is in production to support existing customers, but TI does not recommend using this part in a new design.

PREVIEW: Device has been announced but is not in production. Samples may or may not be available.

OBSOLETE: TI has discontinued the production of the device.

(2) **RoHS:** TI defines "RoHS" to mean semiconductor products that are compliant with the current EU RoHS requirements for all 10 RoHS substances, including the requirement that RoHS substance do not exceed 0.1% by weight in homogeneous materials. Where designed to be soldered at high temperatures, "RoHS" products are suitable for use in specified lead-free processes. TI may reference these types of products as "Pb-Free".

RoHS Exempt: TI defines "RoHS Exempt" to mean products that contain lead but are compliant with EU RoHS pursuant to a specific EU RoHS exemption.

Green: TI defines "Green" to mean the content of Chlorine (Cl) and Bromine (Br) based flame retardants meet JS709B low halogen requirements of ≤ 1000 ppm threshold. Antimony trioxide based flame retardants must also meet the ≤ 1000 ppm threshold requirement.

(3) MSL, Peak Temp. - The Moisture Sensitivity Level rating according to the JEDEC industry standard classifications, and peak solder temperature.

(4) There may be additional marking, which relates to the logo, the lot trace code information, or the environmental category on the device.

(5) Multiple Device Markings will be inside parentheses. Only one Device Marking contained in parentheses and separated by a "~" will appear on a device. If a line is indented then it is a continuation of the previous line and the two combined represent the entire Device Marking for that device.

(6) Lead finish/Ball material - Orderable Devices may have multiple material finish options. Finish options are separated by a vertical ruled line. Lead finish/Ball material values may wrap to two lines if the finish value exceeds the maximum column width.

Important Information and Disclaimer: The information provided on this page represents TI's knowledge and belief as of the date that it is provided. TI bases its knowledge and belief on information provided by third parties, and makes no representation or warranty as to the accuracy of such information. Efforts are underway to better integrate information from third parties. TI has taken and continues to take reasonable steps to provide representative and accurate information but may not have conducted destructive testing or chemical analysis on incoming materials and chemicals. TI and TI suppliers consider certain information to be proprietary, and thus CAS numbers and other limited information may not be available for release.

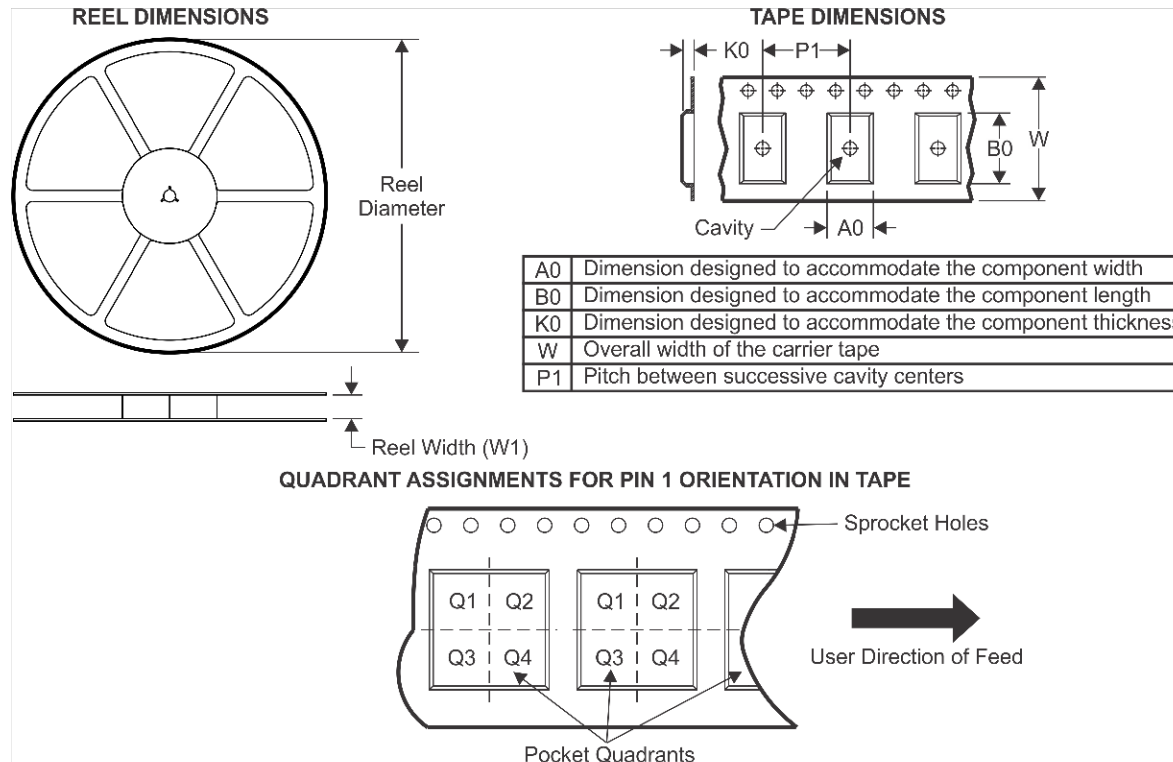
In no event shall TI's liability arising out of such information exceed the total purchase price of the TI part(s) at issue in this document sold by TI to Customer on an annual basis.

OTHER QUALIFIED VERSIONS OF SN74LVC4245A :

- Enhanced Product: [SN74LVC4245A-EP](#)

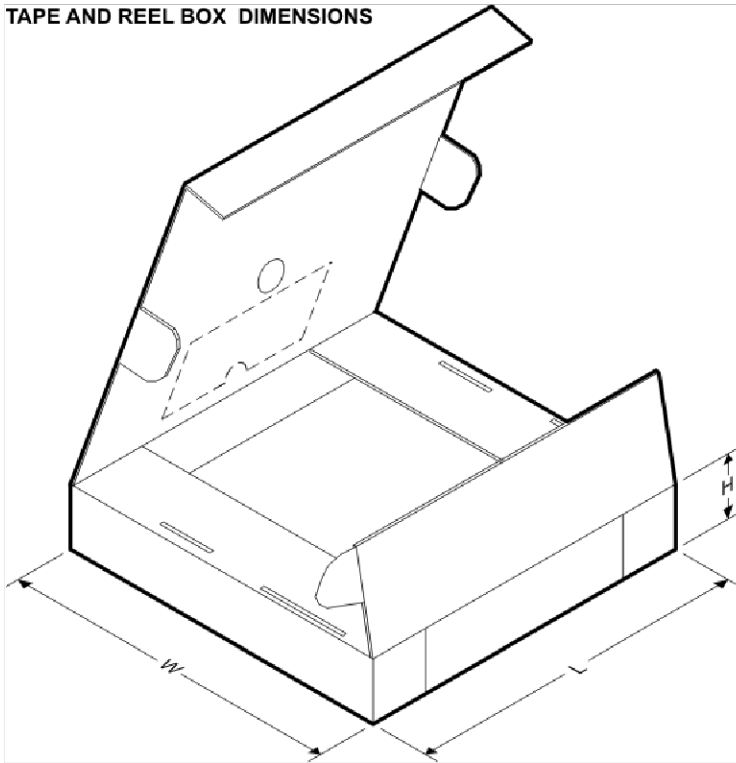
NOTE: Qualified Version Definitions:

- Enhanced Product - Supports Defense, Aerospace and Medical Applications

TAPE AND REEL INFORMATION


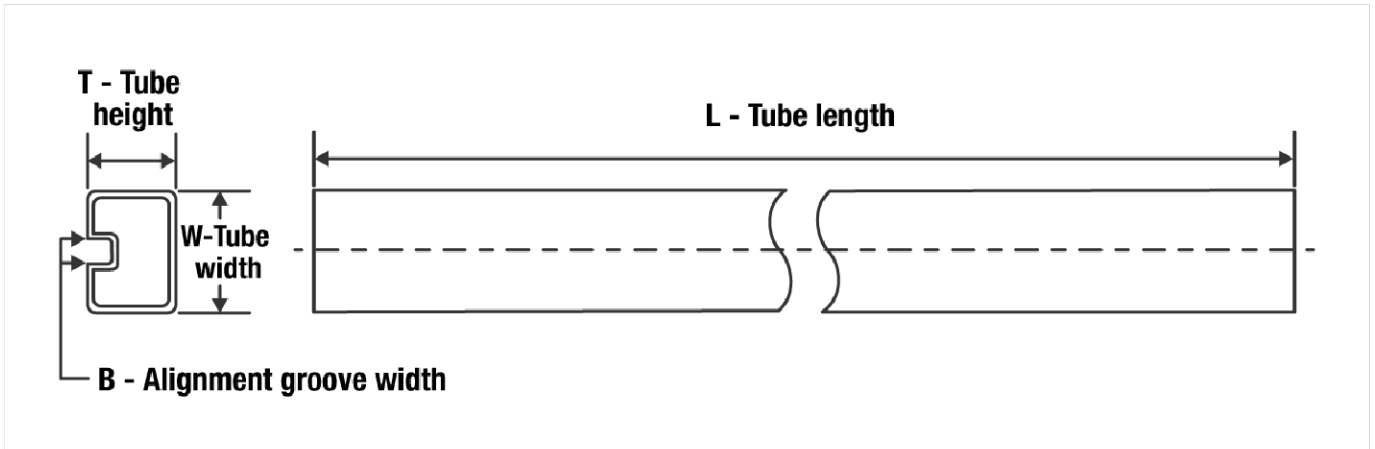
*All dimensions are nominal

Device	Package Type	Package Drawing	Pins	SPQ	Reel Diameter (mm)	Reel Width W1 (mm)	A0 (mm)	B0 (mm)	K0 (mm)	P1 (mm)	W (mm)	Pin1 Quadrant
SN74LVC4245ADBR	SSOP	DB	24	2000	330.0	16.4	8.2	8.8	2.5	12.0	16.0	Q1
SN74LVC4245ADWR	SOIC	DW	24	2000	330.0	24.4	10.75	15.7	2.7	12.0	24.0	Q1
SN74LVC4245ADWR	SOIC	DW	24	2000	330.0	24.4	10.75	15.7	2.7	12.0	24.0	Q1
SN74LVC4245ADWRG4	SOIC	DW	24	2000	330.0	24.4	10.75	15.7	2.7	12.0	24.0	Q1
SN74LVC4245APWR	TSSOP	PW	24	2000	330.0	16.4	6.95	8.3	1.6	8.0	16.0	Q1
SN74LVC4245APWT	TSSOP	PW	24	250	330.0	16.4	6.95	8.3	1.6	8.0	16.0	Q1

TAPE AND REEL BOX DIMENSIONS


*All dimensions are nominal

Device	Package Type	Package Drawing	Pins	SPQ	Length (mm)	Width (mm)	Height (mm)
SN74LVC4245ADBR	SSOP	DB	24	2000	853.0	449.0	35.0
SN74LVC4245ADWR	SOIC	DW	24	2000	364.0	361.0	36.0
SN74LVC4245ADWR	SOIC	DW	24	2000	350.0	350.0	43.0
SN74LVC4245ADWRG4	SOIC	DW	24	2000	350.0	350.0	43.0
SN74LVC4245APWR	TSSOP	PW	24	2000	853.0	449.0	35.0
SN74LVC4245APWT	TSSOP	PW	24	250	853.0	449.0	35.0

TUBE


*All dimensions are nominal

Device	Package Name	Package Type	Pins	SPQ	L (mm)	W (mm)	T (μm)	B (mm)
SN74LVC4245ADW	DW	SOIC	24	25	506.98	12.7	4826	6.6
SN74LVC4245ADWE4	DW	SOIC	24	25	506.98	12.7	4826	6.6
SN74LVC4245ADWG4	DW	SOIC	24	25	506.98	12.7	4826	6.6
SN74LVC4245APW	PW	TSSOP	24	60	530	10.2	3600	3.5
SN74LVC4245APWG4	PW	TSSOP	24	60	530	10.2	3600	3.5

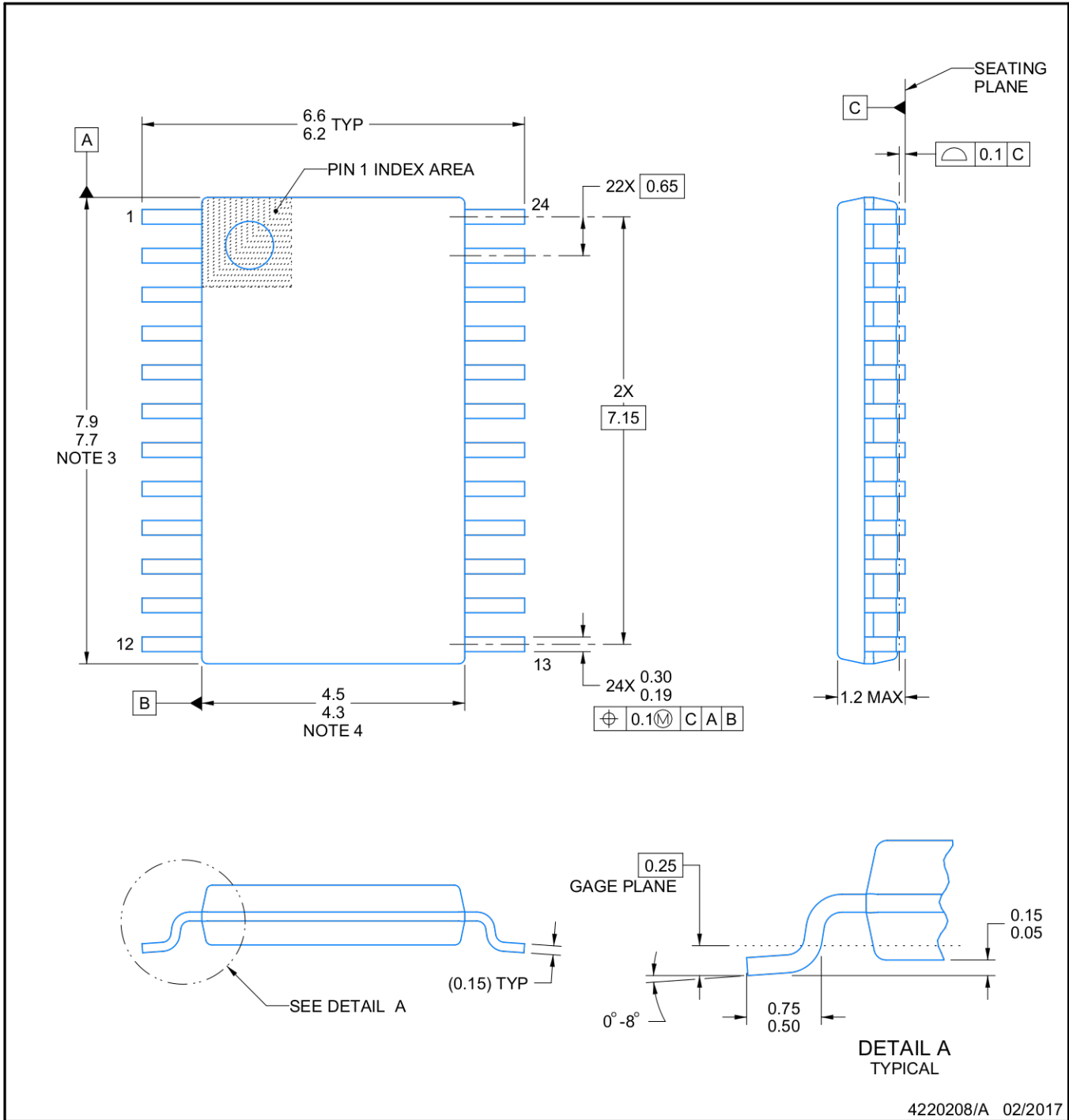
PW0024A



PACKAGE OUTLINE

TSSOP - 1.2 mm max height

SMALL OUTLINE PACKAGE



4220208/A 02/2017

NOTES:

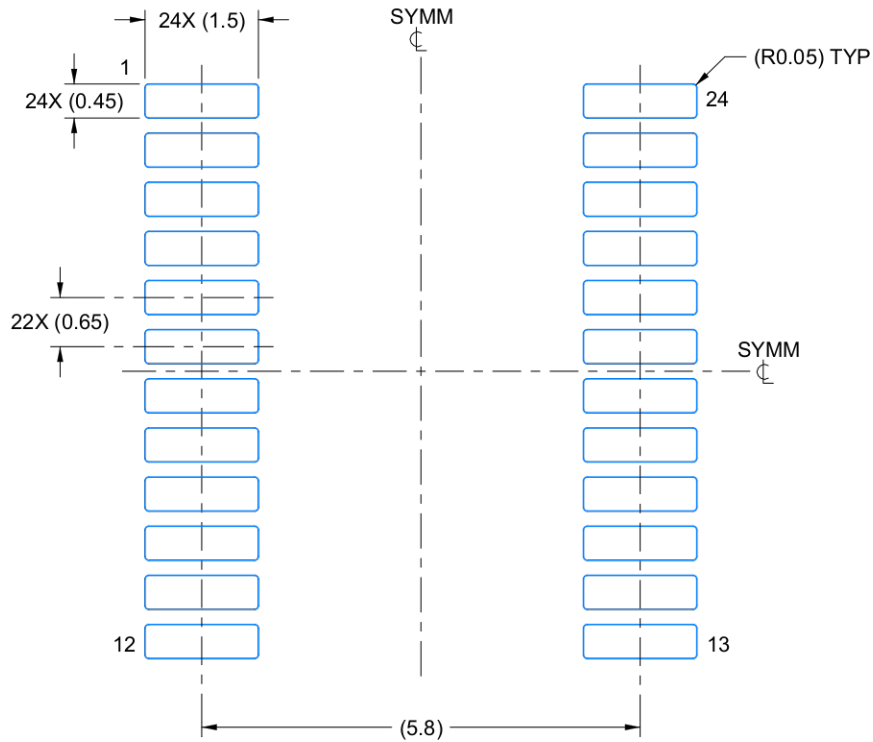
1. All linear dimensions are in millimeters. Any dimensions in parenthesis are for reference only. Dimensioning and tolerancing per ASME Y14.5M.
2. This drawing is subject to change without notice.
3. This dimension does not include mold flash, protrusions, or gate burrs. Mold flash, protrusions, or gate burrs shall not exceed 0.15 mm per side.
4. This dimension does not include interlead flash. Interlead flash shall not exceed 0.25 mm per side.
5. Reference JEDEC registration MO-153.

EXAMPLE BOARD LAYOUT

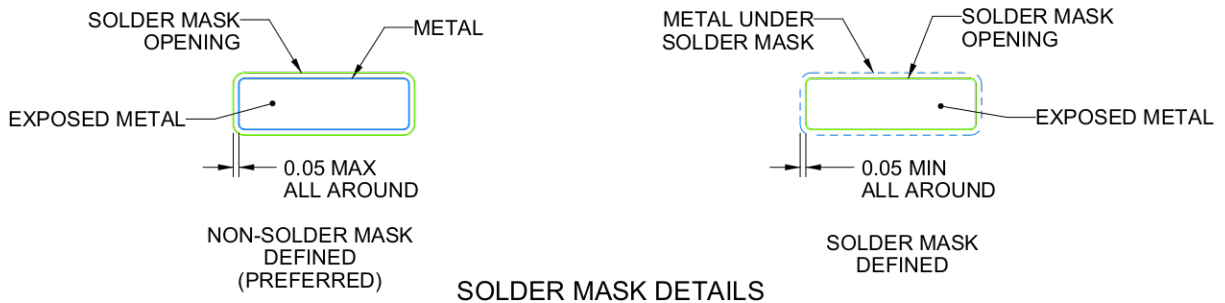
PW0024A

TSSOP - 1.2 mm max height

SMALL OUTLINE PACKAGE



LAND PATTERN EXAMPLE
EXPOSED METAL SHOWN
SCALE: 10X



SOLDER MASK DETAILS

4220208/A 02/2017

NOTES: (continued)

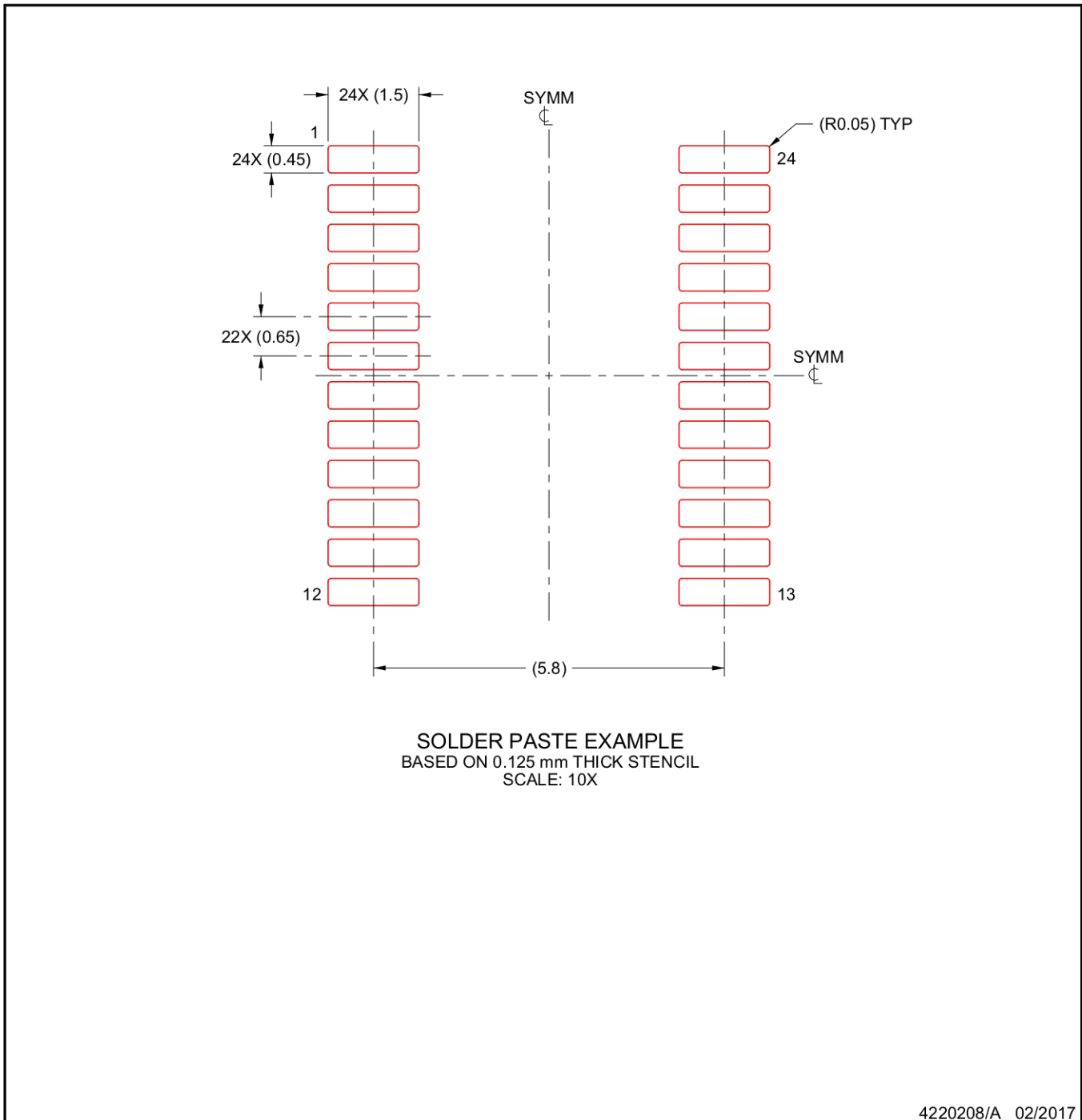
6. Publication IPC-7351 may have alternate designs.
7. Solder mask tolerances between and around signal pads can vary based on board fabrication site.

EXAMPLE STENCIL DESIGN

PW0024A

TSSOP - 1.2 mm max height

SMALL OUTLINE PACKAGE

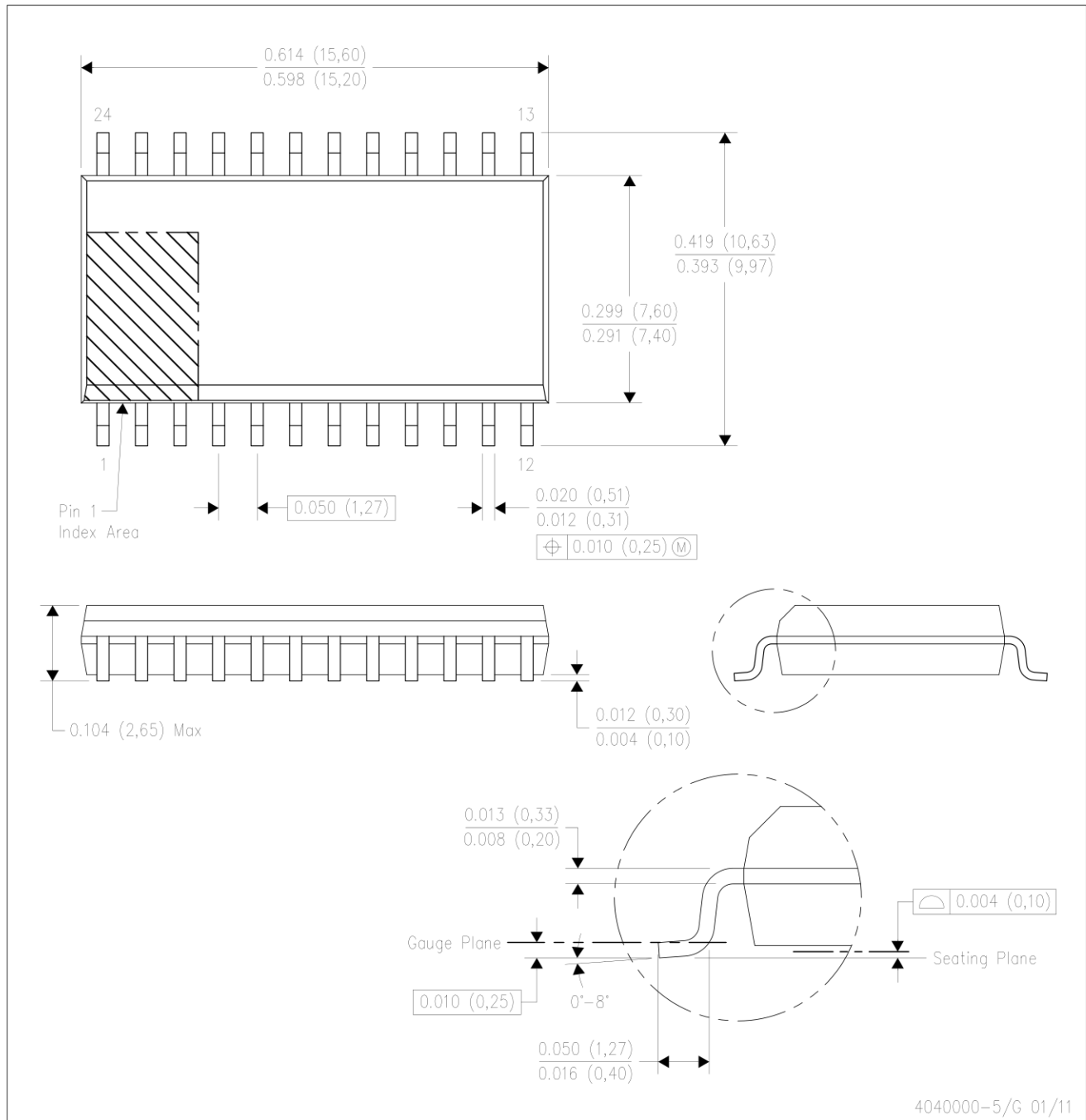


NOTES: (continued)

8. Laser cutting apertures with trapezoidal walls and rounded corners may offer better paste release. IPC-7525 may have alternate design recommendations.
9. Board assembly site may have different recommendations for stencil design.

DW (R-PDSO-G24)

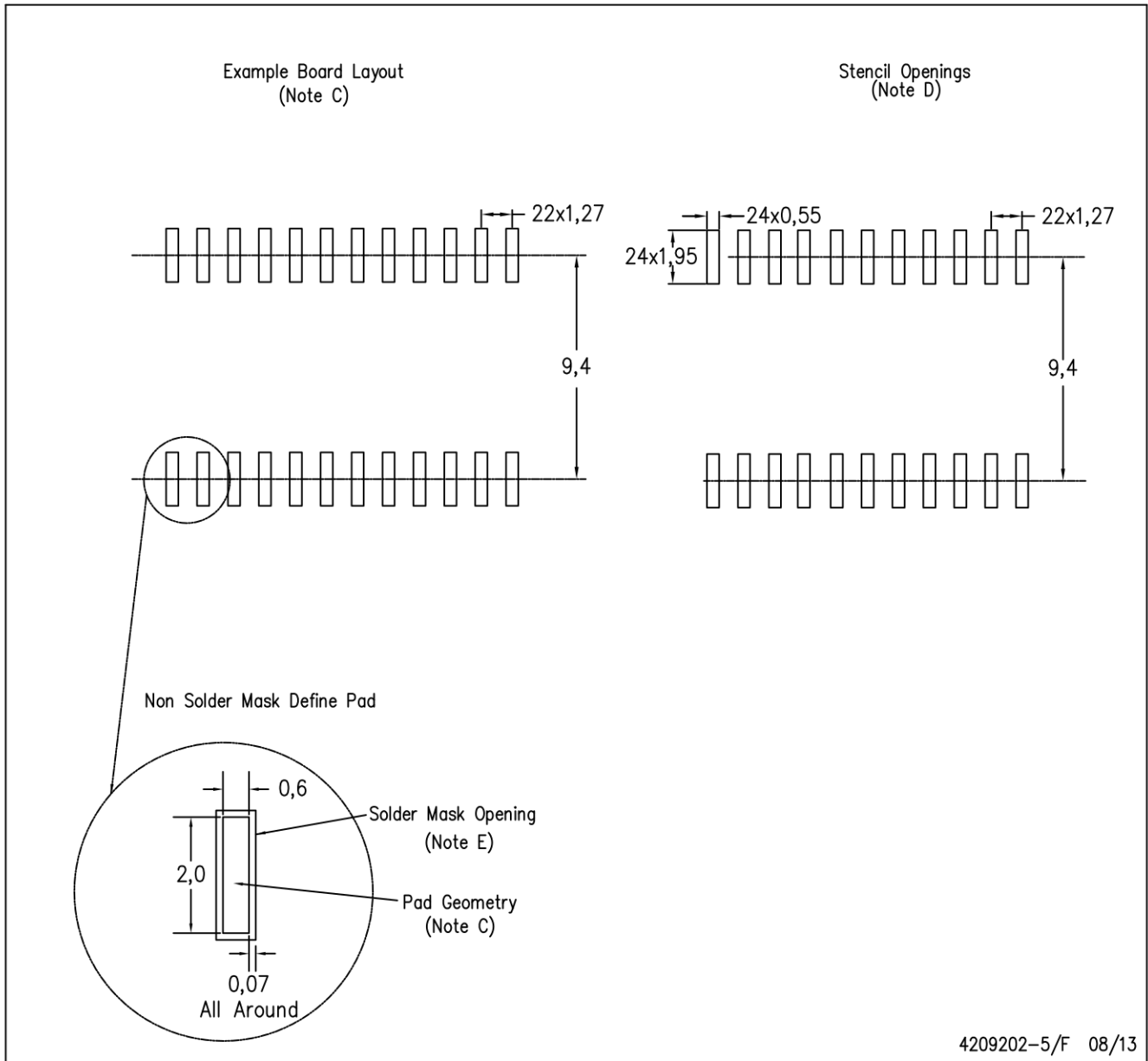
PLASTIC SMALL OUTLINE



- NOTES:
- A. All linear dimensions are in inches (millimeters). Dimensioning and tolerancing per ASME Y14.5M-1994.
 - B. This drawing is subject to change without notice.
 - C. Body dimensions do not include mold flash or protrusion not to exceed 0.006 (0,15).
 - D. Falls within JEDEC MS-013 variation AD.

DW (R-PDSO-G24)

PLASTIC SMALL OUTLINE



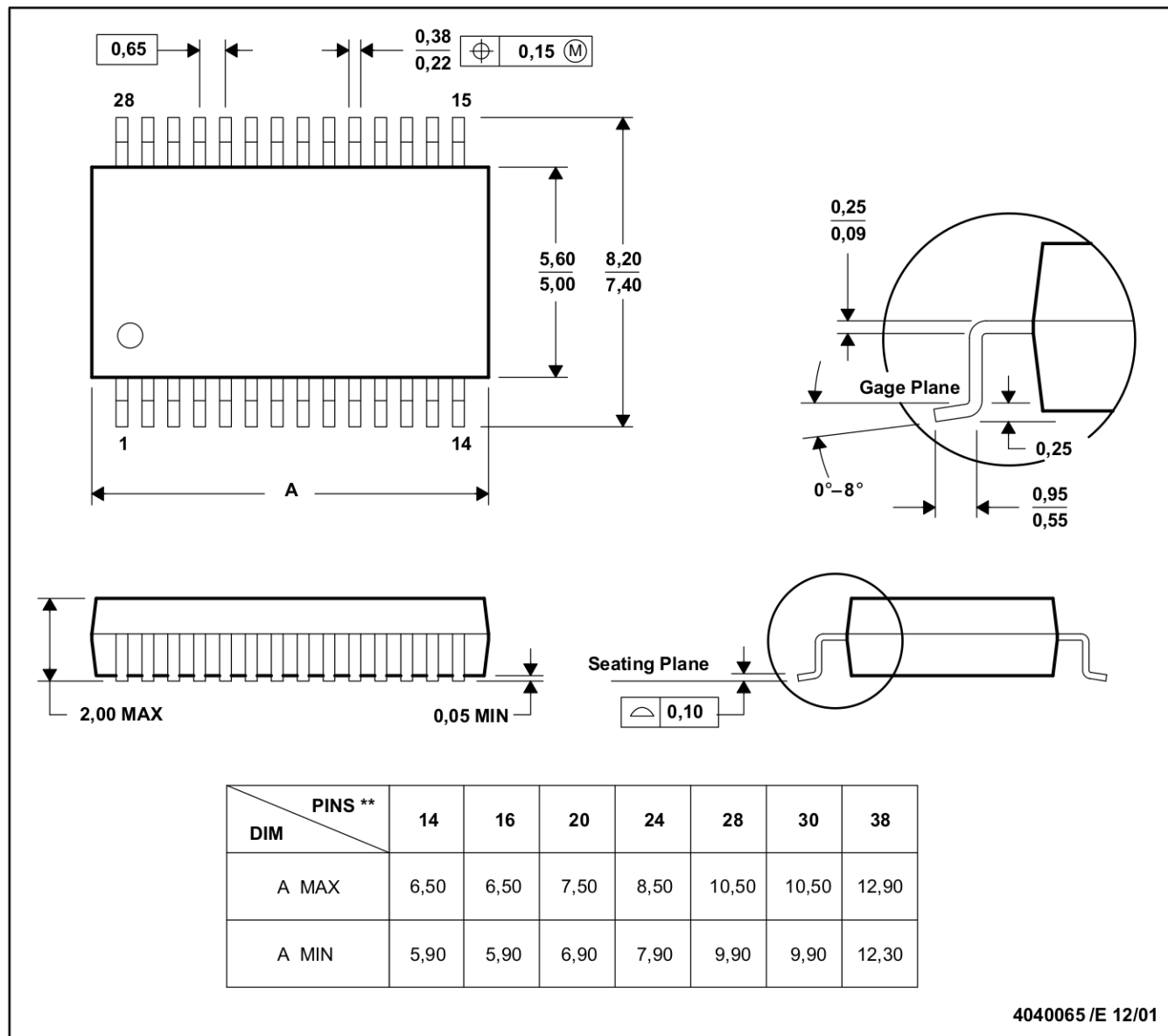
4209202-5/F 08/13

- NOTES:
- A. All linear dimensions are in millimeters.
 - B. This drawing is subject to change without notice.
 - C. Refer to IPC7351 for alternate board design.
 - D. Laser cutting apertures with trapezoidal walls and also rounding corners will offer better paste release. Customers should contact their board assembly site for stencil design recommendations. Refer to IPC-7525
 - E. Customers should contact their board fabrication site for solder mask tolerances between and around signal pads.

DB (R-PDSO-G**)

PLASTIC SMALL-OUTLINE

28 PINS SHOWN



- NOTES: A. All linear dimensions are in millimeters.
 B. This drawing is subject to change without notice.
 C. Body dimensions do not include mold flash or protrusion not to exceed 0,15.
 D. Falls within JEDEC MO-150

4040065 /E 12/01

IMPORTANT NOTICE AND DISCLAIMER

TI PROVIDES TECHNICAL AND RELIABILITY DATA (INCLUDING DATA SHEETS), DESIGN RESOURCES (INCLUDING REFERENCE DESIGNS), APPLICATION OR OTHER DESIGN ADVICE, WEB TOOLS, SAFETY INFORMATION, AND OTHER RESOURCES "AS IS" AND WITH ALL FAULTS, AND DISCLAIMS ALL WARRANTIES, EXPRESS AND IMPLIED, INCLUDING WITHOUT LIMITATION ANY IMPLIED WARRANTIES OF MERCHANTABILITY, FITNESS FOR A PARTICULAR PURPOSE OR NON-INFRINGEMENT OF THIRD PARTY INTELLECTUAL PROPERTY RIGHTS.

These resources are intended for skilled developers designing with TI products. You are solely responsible for (1) selecting the appropriate TI products for your application, (2) designing, validating and testing your application, and (3) ensuring your application meets applicable standards, and any other safety, security, regulatory or other requirements.

These resources are subject to change without notice. TI grants you permission to use these resources only for development of an application that uses the TI products described in the resource. Other reproduction and display of these resources is prohibited. No license is granted to any other TI intellectual property right or to any third party intellectual property right. TI disclaims responsibility for, and you will fully indemnify TI and its representatives against, any claims, damages, costs, losses, and liabilities arising out of your use of these resources.

TI's products are provided subject to [TI's Terms of Sale](#) or other applicable terms available either on [ti.com](#) or provided in conjunction with such TI products. TI's provision of these resources does not expand or otherwise alter TI's applicable warranties or warranty disclaimers for TI products.

TI objects to and rejects any additional or different terms you may have proposed. [IMPORTANT NOTICE](#)

Mailing Address: Texas Instruments, Post Office Box 655303, Dallas, Texas 75265
Copyright © 2022, Texas Instruments Incorporated