

# SN75372 DUAL MOSFET DRIVER

SLLS025A - JULY 1986

- Dual Circuits Capable of Driving High-Capacitance Loads at High Speeds
- Output Supply Voltage Range up to 24 V
- Low Standby Power Dissipation

## description

The SN75372 is a dual NAND gate interface circuit designed to drive power MOSFETs from TTL inputs. It provides high current and voltage levels necessary to drive large capacitive loads at high speeds. The device operates from a  $V_{CC1}$  of 5 V and a  $V_{CC2}$  of up to 24 V.

The SN75372 is characterized for operation from 0°C to 70°C.

D OR P PACKAGE  
(TOP VIEW)

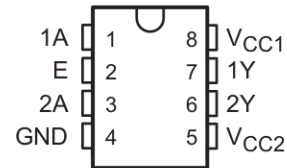

## logic symbol†

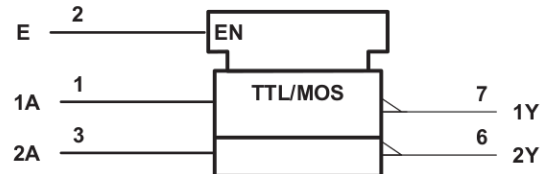

† This symbol is in accordance with ANSI/IEEE Std 91-1984 and IEC Publication 617-12.

## schematic (each driver)

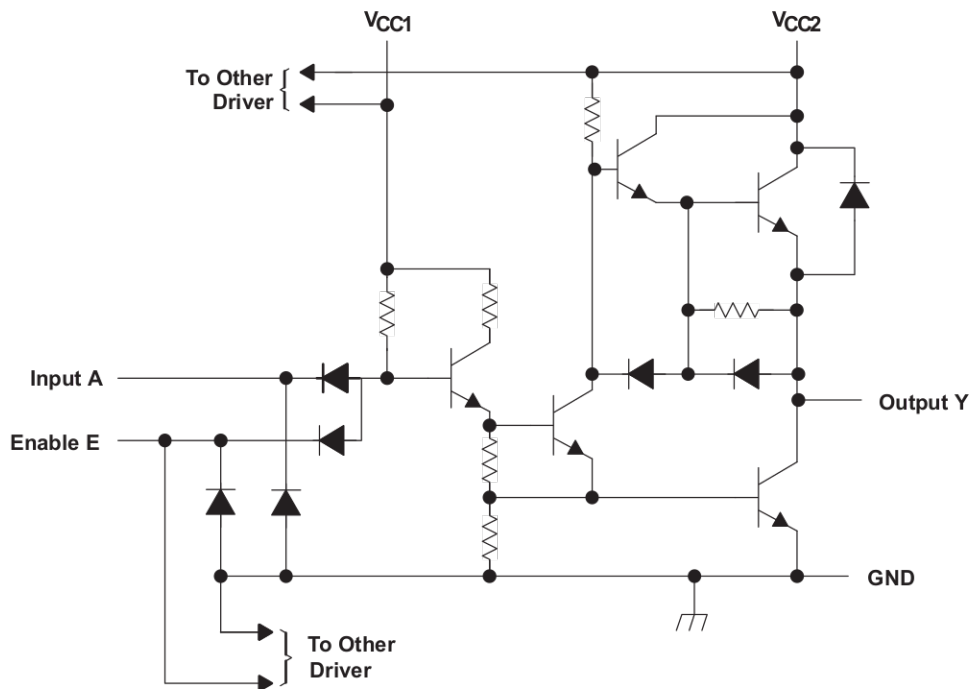

PRODUCTION DATA information is current as of publication date. Products conform to specifications per the terms of Texas Instruments standard warranty. Production processing does not necessarily include testing of all parameters.

 **TEXAS  
INSTRUMENTS**

POST OFFICE BOX 655303 • DALLAS, TEXAS 75265  
POST OFFICE BOX 1443 • HOUSTON, TEXAS 77251-1443

Copyright © 1986, Texas Instruments Incorporated  
Revision Information

# SN75372 DUAL MOSFET DRIVER

SLLS025A – JULY 1986

## absolute maximum ratings over operating free-air temperature range (unless otherwise noted)†

Supply voltage range, $V_{CC1}$ (see Note 1)	-0.5 V to 7 V
Supply voltage range, $V_{CC2}$	-0.5 V to 25 V
Input voltage, $V_I$	5.5 V
Peak output current, $I_O$ ( $t_w < 10$ ms, duty cycle $< 50\%$ )	500 mA
Continuous total power dissipation	See Dissipation Rating Table
Operating free-air temperature range, $T_A$	0°C to 70°C
Storage temperature range, $T_{stg}$	-65°C to 150°C
Lead temperature 1,6 mm (1/16 inch) from case for 10 seconds	260°C

† Stresses beyond those listed under “absolute maximum ratings” may cause permanent damage to the device. These are stress ratings only, and functional operation of the device at these or any other conditions beyond those indicated under “recommended operating conditions” is not implied. Exposure to absolute-maximum-rated conditions for extended periods may affect device reliability.

NOTE 1: Voltage values are with respect to network GND.

DISSIPATION RATING TABLE

PACKAGE	$T_A = 25^\circ\text{C}$ POWER RATING	DERATING FACTOR ABOVE $T_A = 25^\circ\text{C}$	$T_A = 70^\circ\text{C}$ POWER RATING
D	725 mW	5.8 mW/°C	464 mW
P	1000 mW	8.0 mW/°C	640 mW

## recommended operating conditions

	MIN	NOM	MAX	UNIT
Supply voltage, $V_{CC1}$	4.75	5	5.25	V
Supply voltage, $V_{CC2}$	4.75	20	24	V
High-level input voltage, $V_{IH}$	2			V
Low-level input voltage, $V_{IL}$			0.8	V
High-level output current, $I_{OH}$			-10	mA
Low-level output current, $I_{OL}$			40	mA
Operating free-air temperature, $T_A$	0		70	°C

**electrical characteristics over recommended ranges of  $V_{CC1}$ ,  $V_{CC2}$ , and operating free-air temperature (unless otherwise noted)**

PARAMETER		TEST CONDITIONS	MIN	TYP†	MAX	UNIT	
$V_{IK}$	Input clamp voltage	$I_I = -12 \text{ mA}$			-1.5	V	
$V_{OH}$	High-level output voltage	$V_{IL} = 0.8 \text{ V}$ , $I_{OH} = -50 \mu\text{A}$	$V_{CC2} - 1.3$	$V_{CC2} - 0.8$		V	
		$V_{IL} = 0.8 \text{ V}$ , $I_{OH} = -10 \text{ mA}$	$V_{CC2} - 2.5$	$V_{CC2} - 1.8$			
$V_{OL}$	Low-level output voltage	$V_{IH} = 2 \text{ V}$ , $I_{OL} = 10 \text{ mA}$		0.15	0.3	V	
		$V_{CC2} = 15 \text{ V to } 24 \text{ V}$ , $V_{IH} = 2 \text{ V}$ , $I_{OL} = 40 \text{ mA}$		0.25	0.5		
$V_F$	Output clamp-diode forward voltage	$V_I = 0$ , $I_F = 20 \text{ mA}$			1.5	V	
$I_I$	Input current at maximum input voltage	$V_I = 5.5 \text{ V}$			1	mA	
$I_{IH}$	High-level input current	$V_I = 2.4 \text{ V}$			40	$\mu\text{A}$	
			Any A				80
$I_{IL}$	Low-level input current	$V_I = 0.4 \text{ V}$		-1	-1.6	mA	
			Any E		-2		-3.2
$I_{CC1(H)}$	Supply current from $V_{CC1}$ , both outputs high	$V_{CC1} = 5.25 \text{ V}$ , All inputs at 0 V,	$V_{CC2} = 24 \text{ V}$ , No load		2	4	mA
$I_{CC2(H)}$	Supply current from $V_{CC2}$ , both outputs high					0.5	mA
$I_{CC1(L)}$	Supply current from $V_{CC1}$ , both outputs low	$V_{CC1} = 5.25 \text{ V}$ , All inputs at 5 V,	$V_{CC2} = 24 \text{ V}$ , No load		16	24	mA
$I_{CC2(L)}$	Supply current from $V_{CC2}$ , both outputs low				7	13	mA
$I_{CC2(S)}$	Supply current from $V_{CC2}$ , standby condition	$V_{CC1} = 0$ , All inputs at 5 V,	$V_{CC2} = 24 \text{ V}$ , No load			0.5	mA

† All typical values are at  $V_{CC1} = 5 \text{ V}$ ,  $V_{CC2} = 20 \text{ V}$ , and  $T_A = 25^\circ\text{C}$ .

### switching characteristics, $V_{CC1} = 5 \text{ V}$ , $V_{CC2} = 20 \text{ V}$ , $T_A = 25^\circ\text{C}$

PARAMETER		TEST CONDITIONS	MIN	TYP	MAX	UNIT	
$t_{DLH}$	Delay time, low-to-high-level output	$C_L = 390 \text{ pF}$ , $R_D = 10 \Omega$ , See Figure 1		20	35	ns	
$t_{DHL}$	Delay time, high-to-low-level output			10	20	ns	
$t_{TLH}$	Transition time, low-to-high-level output			20	30	ns	
$t_{THL}$	Transition time, high-to-low-level output			20	30	ns	
$t_{PLH}$	Propagation delay time, low-to-high-level output			10	40	65	ns
$t_{PHL}$	Propagation delay time, high-to-low-level output			10	30	50	ns

# SN75372 DUAL MOSFET DRIVER

SLLS025A - JULY 1986

## PARAMETER MEASUREMENT INFORMATION

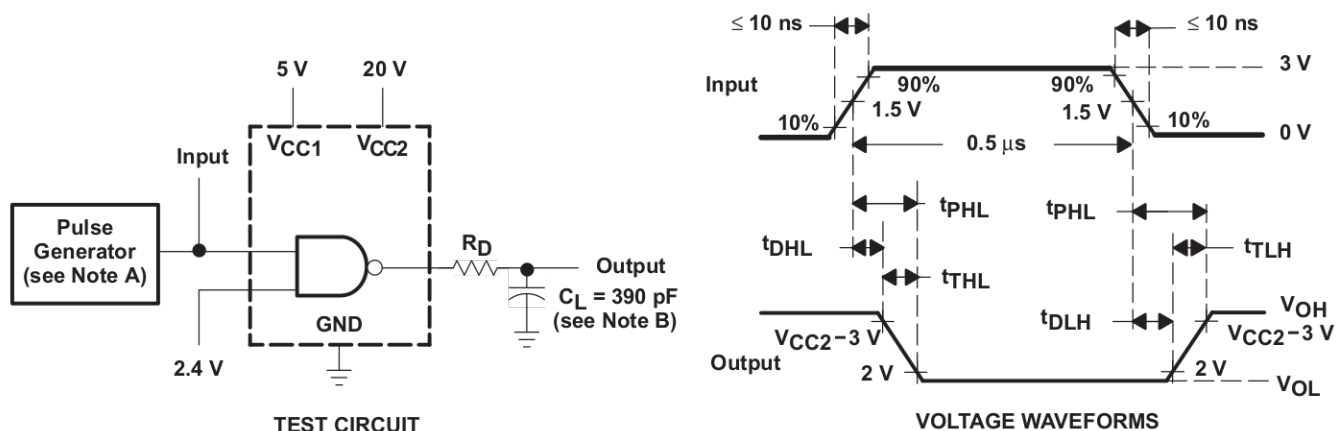

NOTES: A. The pulse generator has the following characteristics: PRR = 1 MHz,  $Z_O \approx 50 \Omega$ .  
B.  $C_L$  includes probe and jig capacitance.

Figure 1. Test Circuit and Voltage Waveforms, Each Driver

## TYPICAL CHARACTERISTICS

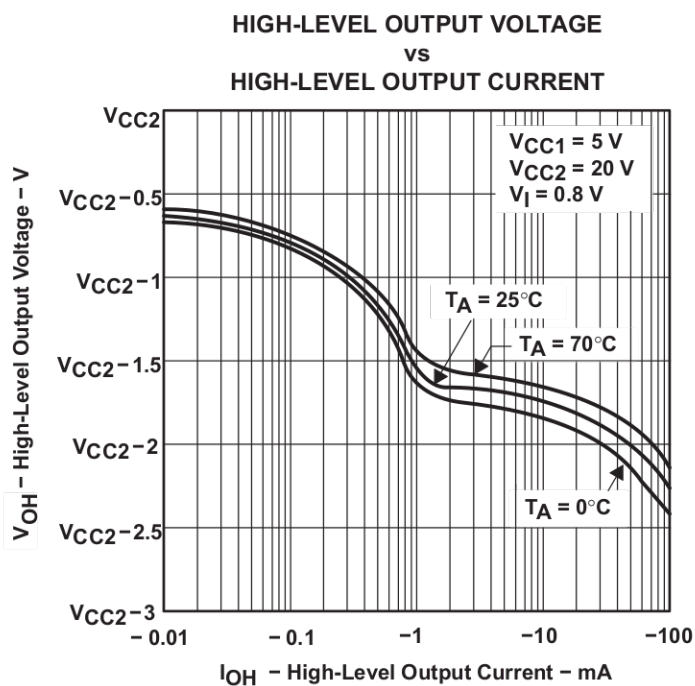

Figure 2

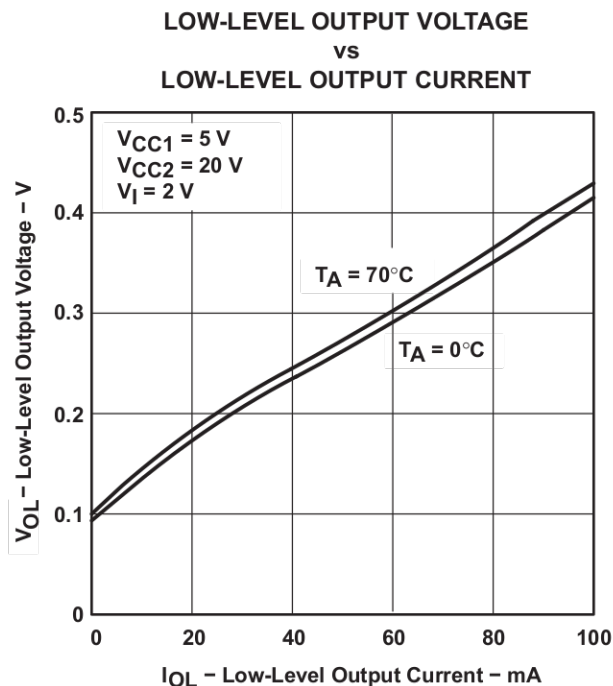

Figure 3



TYPICAL CHARACTERISTICS

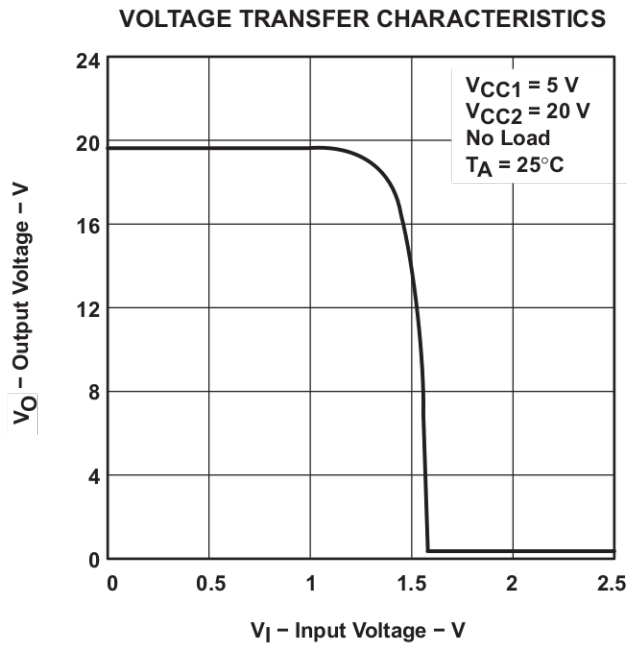

Figure 4

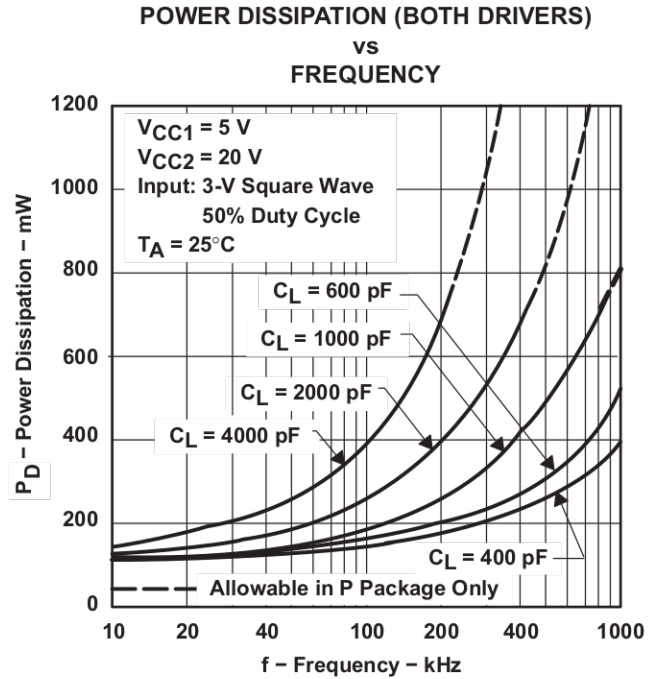

Figure 5

PROPAGATION DELAY TIME,  
LOW-TO-HIGH-LEVEL OUTPUT  
vs  
FREE-AIR TEMPERATURE

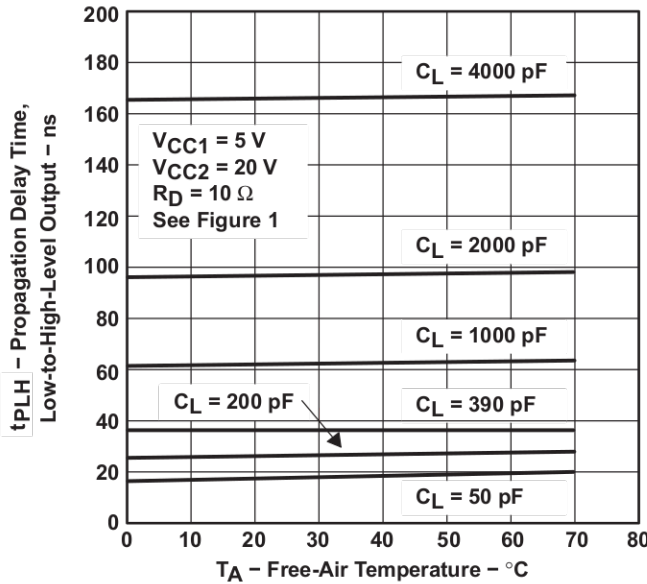

Figure 6

PROPAGATION DELAY TIME,  
HIGH-TO-LOW-LEVEL OUTPUT  
vs  
FREE-AIR TEMPERATURE

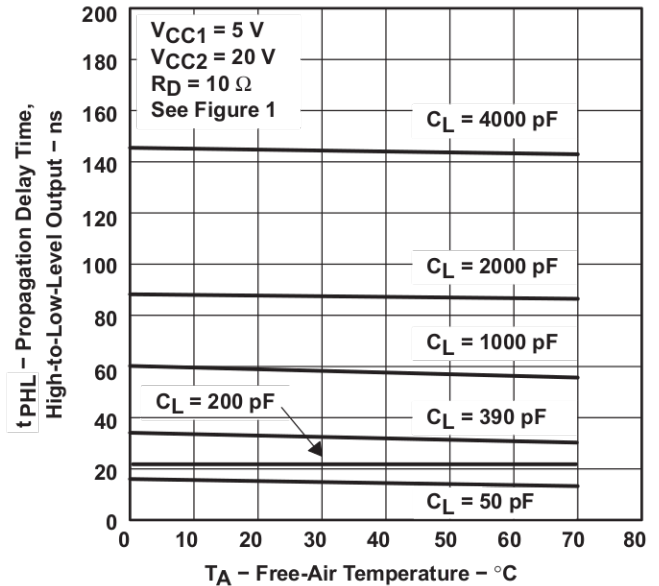
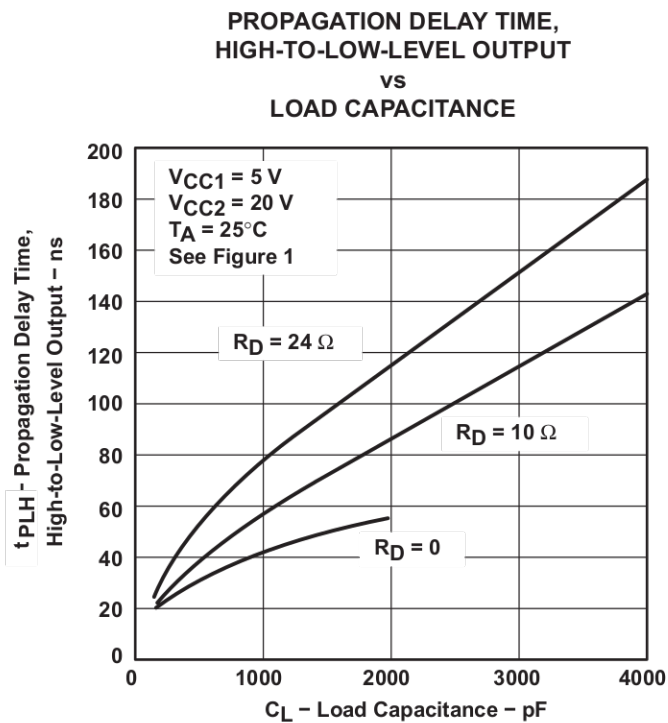
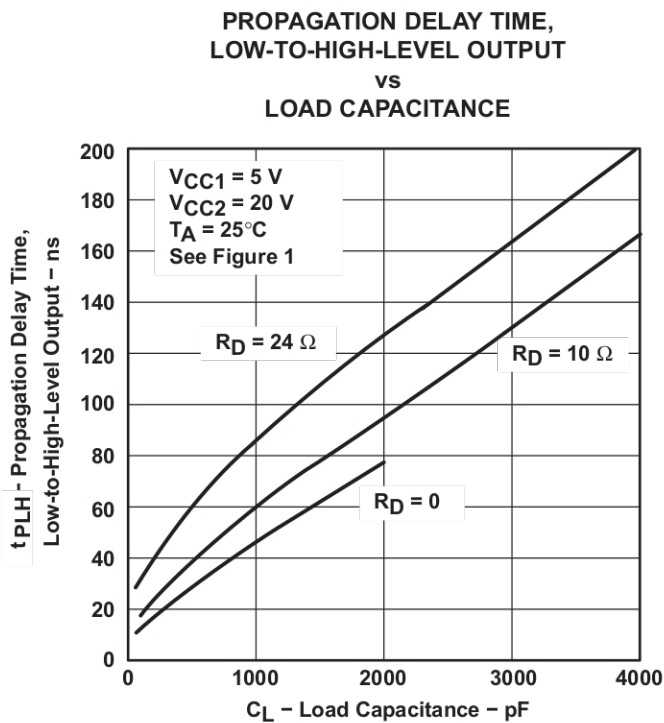
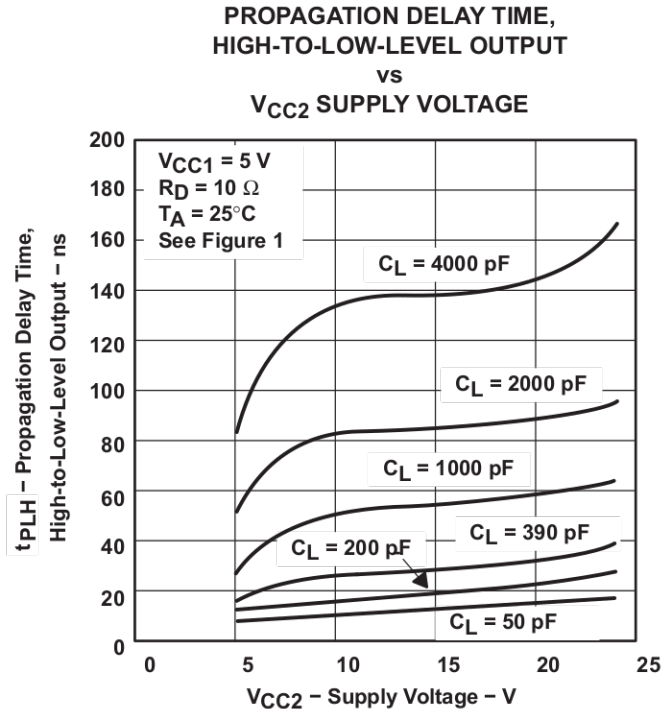
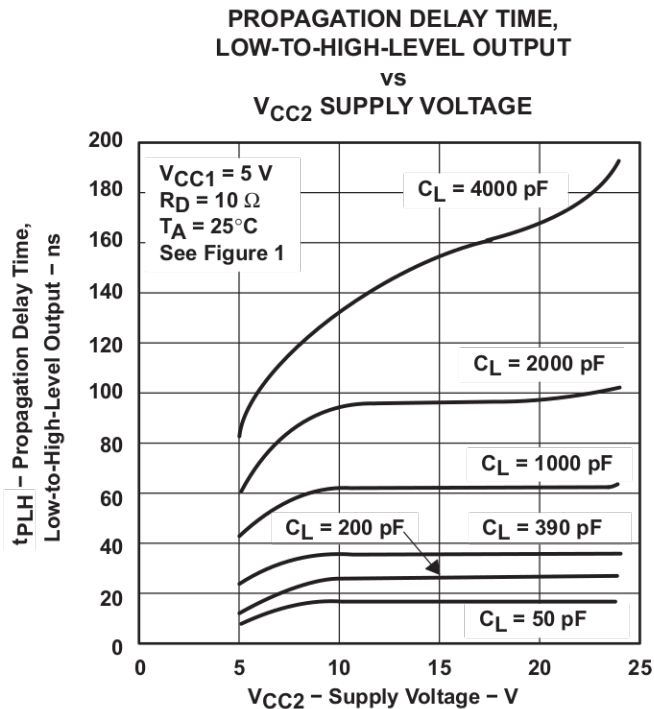

Figure 7

## TYPICAL CHARACTERISTICS



NOTE: For  $R_D = 0$ , operation with  $C_L > 2000$  pF violates absolute maximum current rating.

THERMAL INFORMATION

power dissipation precautions

Significant power may be dissipated in the SN75372 driver when charging and discharging high-capacitance loads over a wide voltage range at high frequencies. Figure 5 shows the power dissipated in a typical SN75372 as a function of load capacitance and frequency. Average power dissipated by this driver is derived from the equation

$$P_{T(AV)} = P_{DC(AV)} + P_{C(AV)} = P_{S(AV)}$$

where  $P_{DC(AV)}$  is the steady-state power dissipation with the output high or low,  $P_{C(AV)}$  is the power level during charging or discharging of the load capacitance, and  $P_{S(AV)}$  is the power dissipation during switching between the low and high levels. None of these include energy transferred to the load, and all are averaged over a full cycle.

The power components per driver channel are

$$P_{DC(AV)} = \frac{P_H t_H + P_L t_L}{T}$$

$$P_{C(AV)} \approx C V_C^2 f$$

$$P_{S(AV)} = \frac{P_{LH} t_{LH} + P_{HL} t_{HL}}{T}$$

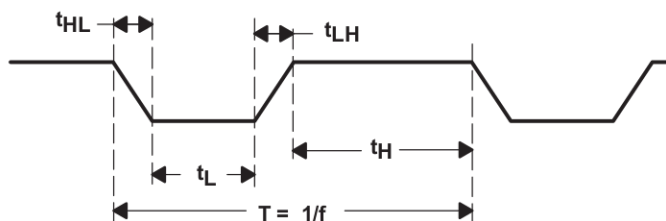

Figure 12. Output Voltage Waveform

where the times are as defined in Figure 14.

$P_L$ ,  $P_H$ ,  $P_{LH}$ , and  $P_{HL}$  are the respective instantaneous levels of power dissipation,  $C$  is the load capacitance.  $V_C$  is the voltage across the load capacitance during the charge cycle shown by the equation

$$V_C = V_{OH} - V_{OL}$$

$P_{S(AV)}$  may be ignored for power calculations at low frequencies.

In the following power calculation, both channels are operating under identical conditions:  $V_{OH} = 19.2$  V and  $V_{OL} = 0.15$  V with  $V_{CC1} = 5$  V,  $V_{CC2} = 20$  V,  $V_C = 19.05$  V,  $C = 1000$  pF, and the duty cycle = 60%. At 0.5 MHz,  $P_{S(AV)}$  is negligible and can be ignored. When the output voltage is high,  $I_{CC2}$  is negligible and can be ignored.

On a per-channel basis using data sheet values,

$$P_{DC(AV)} = \left[ (5 \text{ V}) \left( \frac{2 \text{ mA}}{2} \right) + (20 \text{ V}) \left( \frac{0 \text{ mA}}{2} \right) \right] (0.6) + \left[ (5 \text{ V}) \left( \frac{16 \text{ mA}}{2} \right) + (20 \text{ V}) \left( \frac{7 \text{ mA}}{2} \right) \right] (0.4)$$

$$P_{DC(AV)} = 47 \text{ mW per channel}$$

Power during the charging time of the load capacitance is

$$P_{C(AV)} = (1000 \text{ pF}) (19.05 \text{ V})^2 (0.5 \text{ MHz}) = 182 \text{ mW per channel}$$

Total power for each driver is

$$P_{T(AV)} = 47 \text{ mW} + 182 \text{ mW} = 229 \text{ mW}$$

and total package power is

$$P_{T(AV)} = (229) (2) = 458 \text{ mW.}$$



# SN75372 DUAL MOSFET DRIVER

SLLS025A - JULY 1986

## APPLICATION INFORMATION

### driving power MOSFETs

The drive requirements of power MOSFETs are much lower than comparable bipolar power transistors. The input impedance of a FET consists of a reverse biased PN junction that can be described as a large capacitance in parallel with a very high resistance. For this reason, the commonly used open-collector driver with a pullup resistor is not satisfactory for high-speed applications. In Figure 12(a), an IRF151 power MOSFET switching an inductive load is driven by an open-collector transistor driver with a 470- $\Omega$  pullup resistor. The input capacitance ( $C_{iss}$ ) specification for an IRF151 is 4000 pF maximum. The resulting long turn-on time due to the combination of  $C_{iss}$  and the pullup resistor is shown in Figure 12(b).

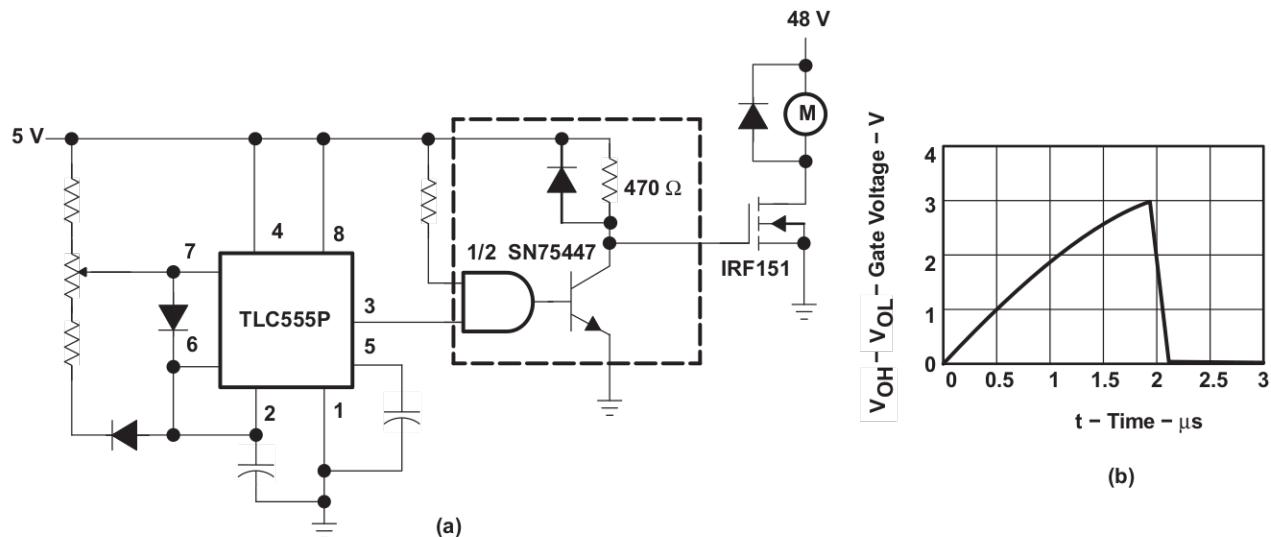
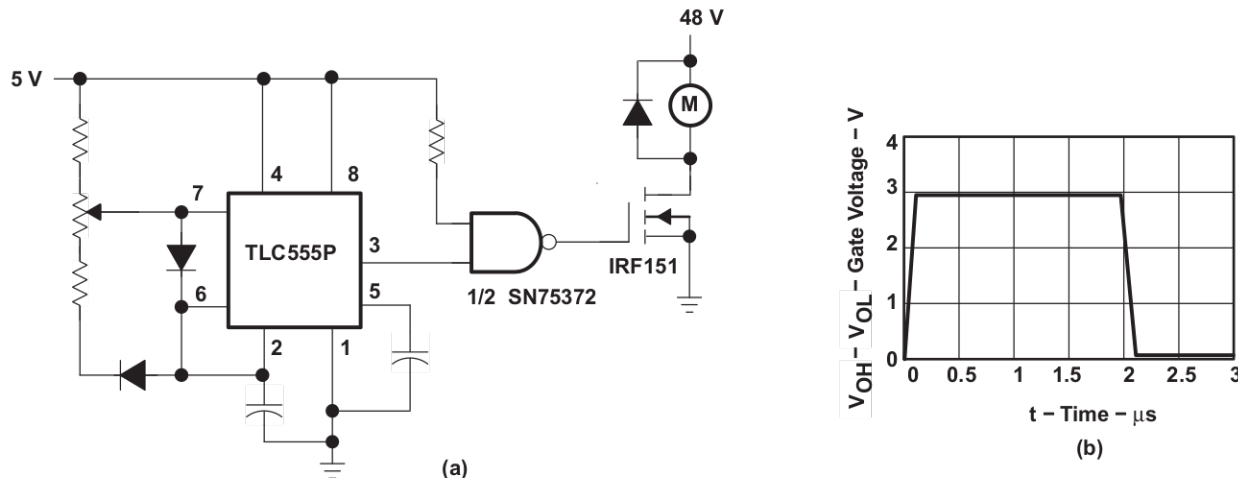

Figure 13. Power MOSFET Drive Using SN75447



**APPLICATION INFORMATION**

A faster, more efficient drive circuit uses an active pullup as well as an active pulldown output configuration, referred to as a totem-pole output. The SN75372 driver provides the high speed, totem-pole drive desired in an application of this type, see Figure 13(a). The resulting faster switching speeds are shown in Figure 13(b).



**Figure 14. Power MOSFET Drive Using SN75372**

Power MOSFET drivers must be capable of supplying high peak currents to achieve fast switching speeds as shown by the equation

$$I_{pk} = \frac{VC}{t_r}$$

where C is the capacitive load, and  $t_r$  is the desired drive time. V is the voltage that the capacitance is charged to. In the circuit shown in Figure 13(a), V is found by the equation

$$V = V_{OH} - V_{OL}$$

Peak current required to maintain a rise time of 100 ns in the circuit of Figure 13(a) is

$$I_{PK} = \frac{(3 - 0)4(10^{-9})}{100(10^{-9})} = 120 \text{ mA}$$

Circuit capacitance can be ignored because it is very small compared to the input capacitance of the IRF151. With a  $V_{CC}$  of 5 V, and assuming worst-case conditions, the gate drive voltage is 3 V.

For applications in which the full voltage of  $V_{CC2}$  must be supplied to the MOSFET gate, the SN75374 quad MOSFET driver should be used.

**PACKAGING INFORMATION**

Orderable Device	Status (1)	Package Type	Package Drawing	Pins	Package Qty	Eco Plan (2)	Lead finish/ Ball material (6)	MSL Peak Temp (3)	Op Temp (°C)	Device Marking (4/5)	Samples
SN75372D	ACTIVE	SOIC	D	8	75	RoHS & Green	NIPDAU	Level-1-260C-UNLIM	0 to 70	75372	<a href="#">Samples</a>
SN75372DR	ACTIVE	SOIC	D	8	2500	RoHS & Green	NIPDAU	Level-1-260C-UNLIM	0 to 70	75372	<a href="#">Samples</a>
SN75372P	ACTIVE	PDIP	P	8	50	RoHS & Green	NIPDAU	N / A for Pkg Type	0 to 70	SN75372P	<a href="#">Samples</a>
SN75372PE4	ACTIVE	PDIP	P	8	50	RoHS & Green	NIPDAU	N / A for Pkg Type	0 to 70	SN75372P	<a href="#">Samples</a>
SN75372PSR	ACTIVE	SO	PS	8	2000	RoHS & Green	NIPDAU	Level-1-260C-UNLIM	0 to 70	A372	<a href="#">Samples</a>
SN75372PSRE4	ACTIVE	SO	PS	8	2000	RoHS & Green	NIPDAU	Level-1-260C-UNLIM	0 to 70	A372	<a href="#">Samples</a>

(1) The marketing status values are defined as follows:

**ACTIVE:** Product device recommended for new designs.

**LIFEBUY:** TI has announced that the device will be discontinued, and a lifetime-buy period is in effect.

**NRND:** Not recommended for new designs. Device is in production to support existing customers, but TI does not recommend using this part in a new design.

**PREVIEW:** Device has been announced but is not in production. Samples may or may not be available.

**OBSOLETE:** TI has discontinued the production of the device.

(2) **RoHS:** TI defines "RoHS" to mean semiconductor products that are compliant with the current EU RoHS requirements for all 10 RoHS substances, including the requirement that RoHS substance do not exceed 0.1% by weight in homogeneous materials. Where designed to be soldered at high temperatures, "RoHS" products are suitable for use in specified lead-free processes. TI may reference these types of products as "Pb-Free".

**RoHS Exempt:** TI defines "RoHS Exempt" to mean products that contain lead but are compliant with EU RoHS pursuant to a specific EU RoHS exemption.

**Green:** TI defines "Green" to mean the content of Chlorine (Cl) and Bromine (Br) based flame retardants meet JS709B low halogen requirements of <=1000ppm threshold. Antimony trioxide based flame retardants must also meet the <=1000ppm threshold requirement.

(3) MSL, Peak Temp. - The Moisture Sensitivity Level rating according to the JEDEC industry standard classifications, and peak solder temperature.

(4) There may be additional marking, which relates to the logo, the lot trace code information, or the environmental category on the device.

(5) Multiple Device Markings will be inside parentheses. Only one Device Marking contained in parentheses and separated by a "~" will appear on a device. If a line is indented then it is a continuation of the previous line and the two combined represent the entire Device Marking for that device.

(6) Lead finish/Ball material - Orderable Devices may have multiple material finish options. Finish options are separated by a vertical ruled line. Lead finish/Ball material values may wrap to two lines if the finish value exceeds the maximum column width.

**Important Information and Disclaimer:** The information provided on this page represents TI's knowledge and belief as of the date that it is provided. TI bases its knowledge and belief on information provided by third parties, and makes no representation or warranty as to the accuracy of such information. Efforts are underway to better integrate information from third parties. TI has taken and continues to take reasonable steps to provide representative and accurate information but may not have conducted destructive testing or chemical analysis on incoming materials and chemicals. TI and TI suppliers consider certain information to be proprietary, and thus CAS numbers and other limited information may not be available for release.

In no event shall TI's liability arising out of such information exceed the total purchase price of the TI part(s) at issue in this document sold by TI to Customer on an annual basis.

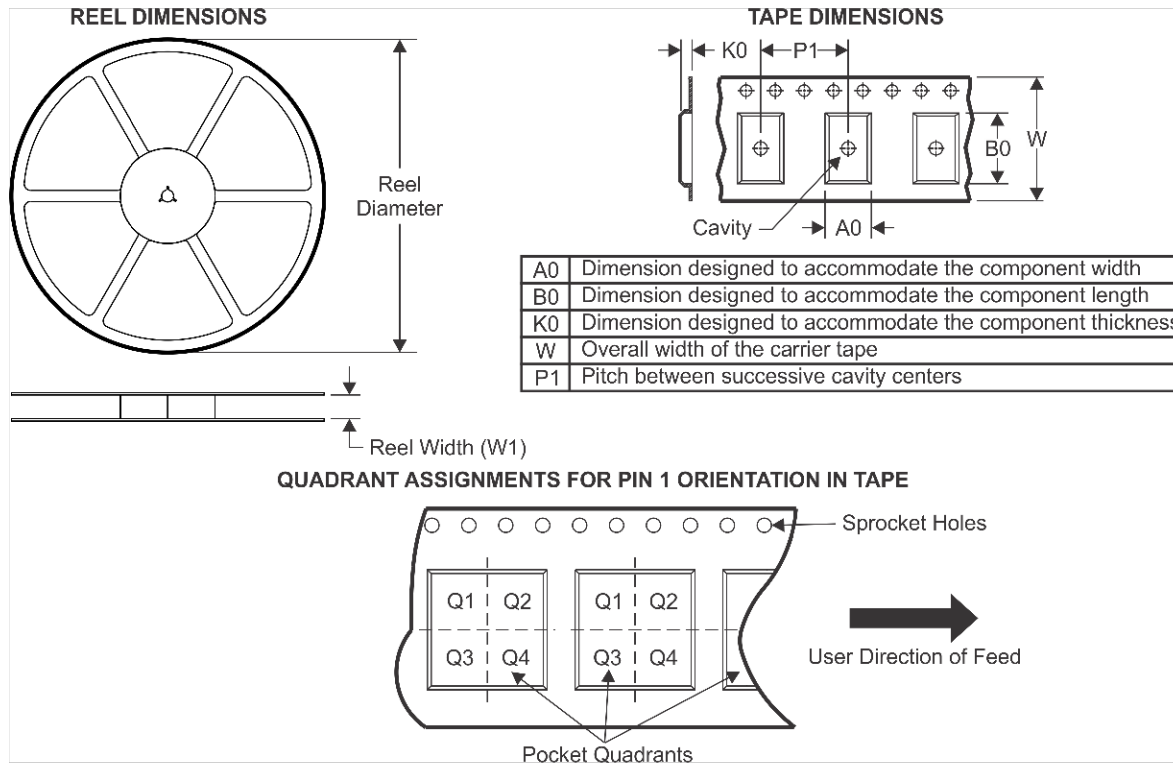
**TAPE AND REEL INFORMATION**

\*All dimensions are nominal

Device	Package Type	Package Drawing	Pins	SPQ	Reel Diameter (mm)	Reel Width W1 (mm)	A0 (mm)	B0 (mm)	K0 (mm)	P1 (mm)	W (mm)	Pin1 Quadrant
SN75372DR	SOIC	D	8	2500	330.0	12.4	6.4	5.2	2.1	8.0	12.0	Q1
SN75372PSR	SO	PS	8	2000	330.0	16.4	8.35	6.6	2.4	12.0	16.0	Q1

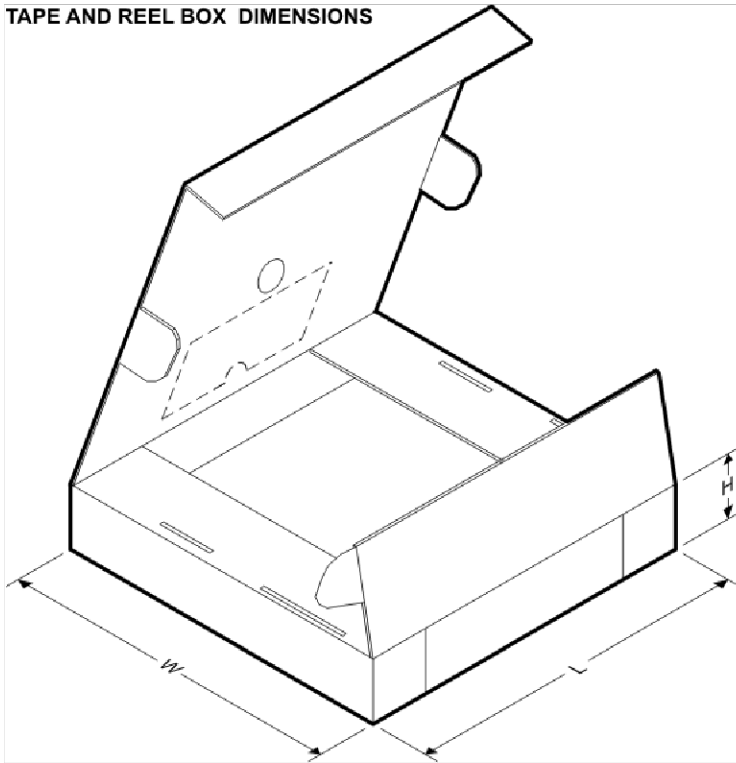
**TAPE AND REEL BOX DIMENSIONS**

\*All dimensions are nominal

Device	Package Type	Package Drawing	Pins	SPQ	Length (mm)	Width (mm)	Height (mm)
SN75372DR	SOIC	D	8	2500	340.5	336.1	25.0
SN75372PSR	SO	PS	8	2000	853.0	449.0	35.0

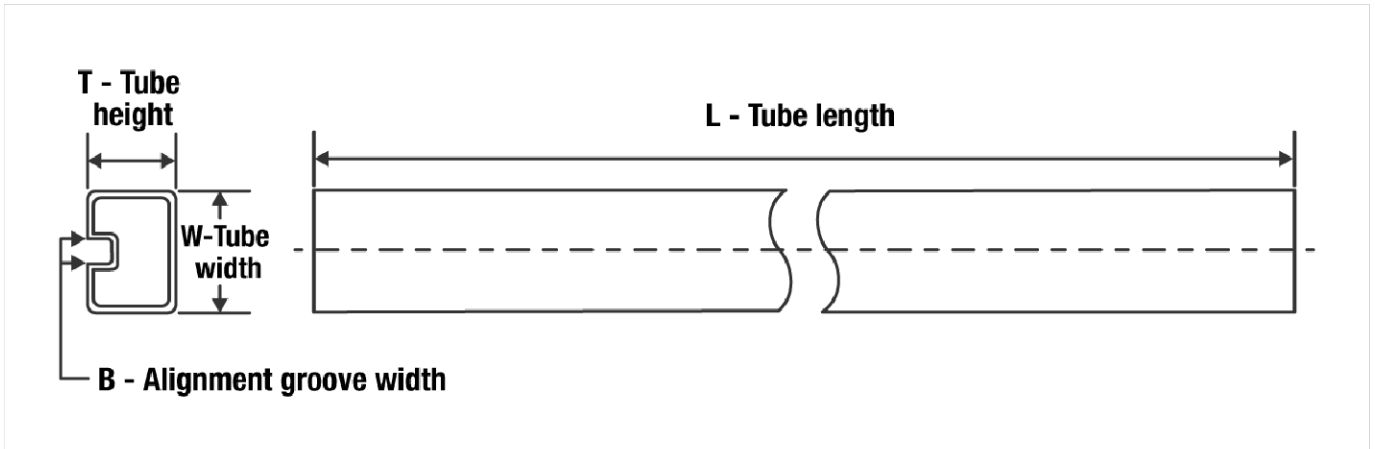
**TUBE**

\*All dimensions are nominal

Device	Package Name	Package Type	Pins	SPQ	L (mm)	W (mm)	T (μm)	B (mm)
SN75372D	D	SOIC	8	75	507	8	3940	4.32
SN75372P	P	PDIP	8	50	506	13.97	11230	4.32
SN75372PE4	P	PDIP	8	50	506	13.97	11230	4.32



D0008A

# PACKAGE OUTLINE

## SOIC - 1.75 mm max height

SMALL OUTLINE INTEGRATED CIRCUIT

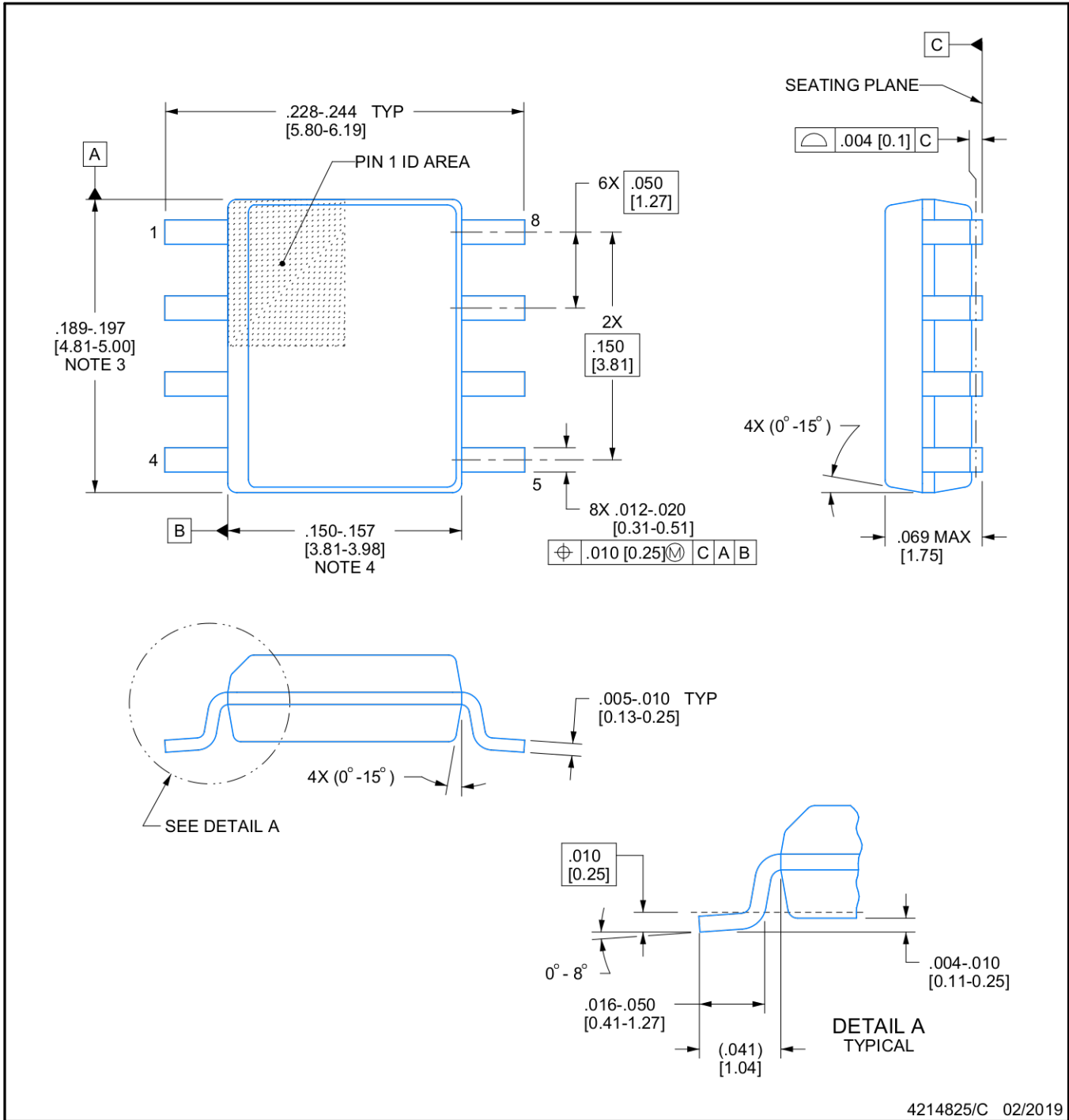

### NOTES:

1. Linear dimensions are in inches [millimeters]. Dimensions in parenthesis are for reference only. Controlling dimensions are in inches. Dimensioning and tolerancing per ASME Y14.5M.
2. This drawing is subject to change without notice.
3. This dimension does not include mold flash, protrusions, or gate burrs. Mold flash, protrusions, or gate burrs shall not exceed  $.006$  [0.15] per side.
4. This dimension does not include interlead flash.
5. Reference JEDEC registration MS-012, variation AA.



# EXAMPLE BOARD LAYOUT

D0008A

SOIC - 1.75 mm max height

SMALL OUTLINE INTEGRATED CIRCUIT

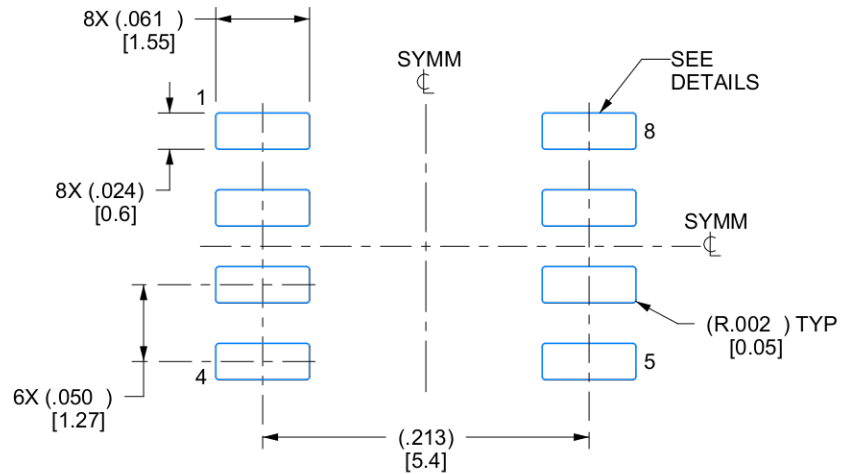

LAND PATTERN EXAMPLE  
EXPOSED METAL SHOWN  
SCALE:8X

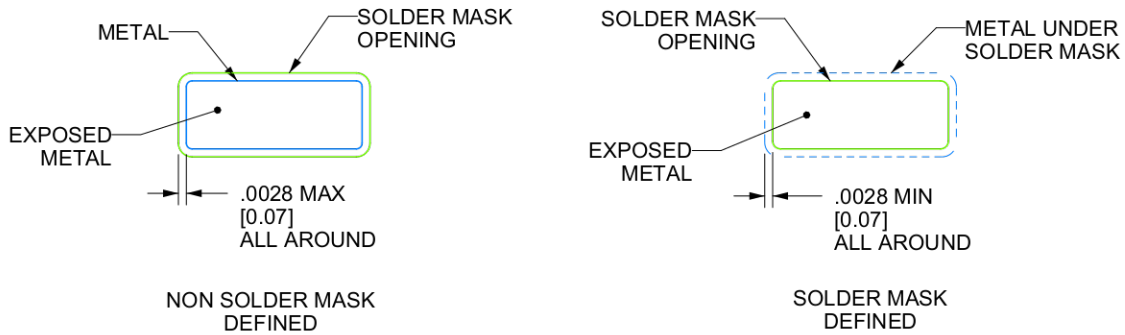

SOLDER MASK DETAILS

4214825/C 02/2019

NOTES: (continued)

- 6. Publication IPC-7351 may have alternate designs.
- 7. Solder mask tolerances between and around signal pads can vary based on board fabrication site.

# EXAMPLE STENCIL DESIGN

D0008A

SOIC - 1.75 mm max height

SMALL OUTLINE INTEGRATED CIRCUIT

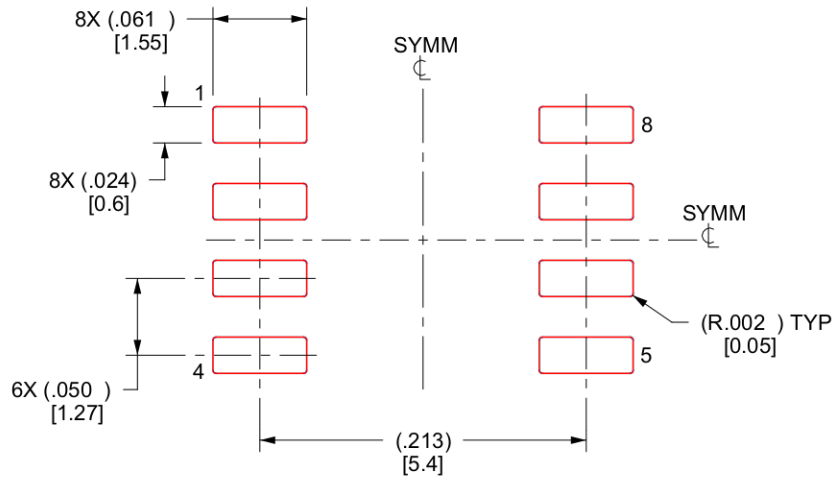

SOLDER PASTE EXAMPLE  
BASED ON .005 INCH [0.125 MM] THICK STENCIL  
SCALE:8X

4214825/C 02/2019

NOTES: (continued)

8. Laser cutting apertures with trapezoidal walls and rounded corners may offer better paste release. IPC-7525 may have alternate design recommendations.
9. Board assembly site may have different recommendations for stencil design.

## MECHANICAL DATA

PS (R-PDSO-G8)

PLASTIC SMALL-OUTLINE PACKAGE

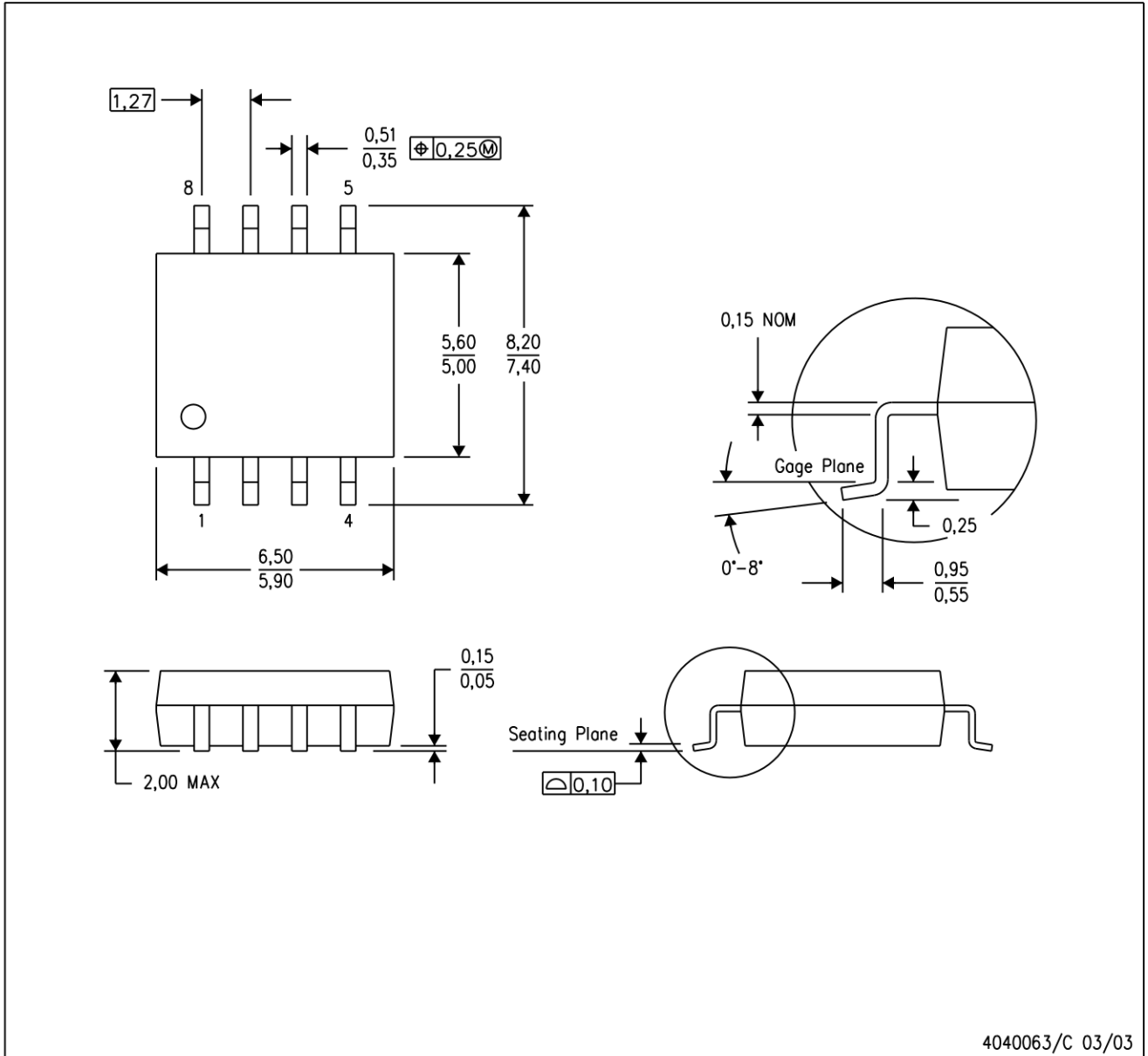

- NOTES:
- A. All linear dimensions are in millimeters.
  - B. This drawing is subject to change without notice.
  - C. Body dimensions do not include mold flash or protrusion, not to exceed 0,15.

PS (R-PDSO-G8)

PLASTIC SMALL OUTLINE

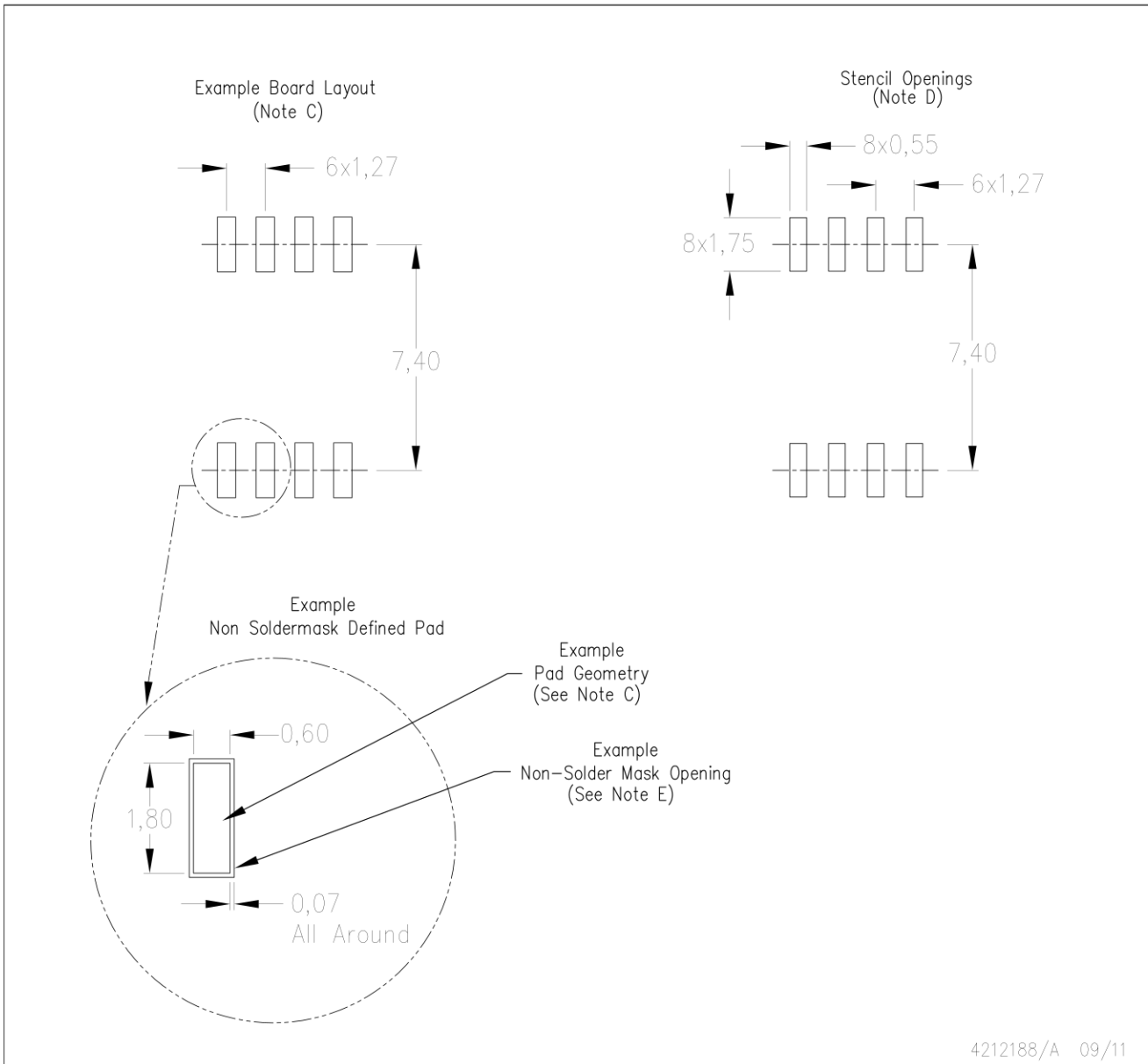

- NOTES:
- A. All linear dimensions are in millimeters.
  - B. This drawing is subject to change without notice.
  - C. Publication IPC-7351 is recommended for alternate designs.
  - D. Laser cutting apertures with trapezoidal walls and also rounding corners will offer better paste release. Customers should contact their board assembly site for stencil design recommendations. Refer to IPC-7525 for other stencil recommendations.
  - E. Customers should contact their board fabrication site for solder mask tolerances between and around signal pads.

P (R-PDIP-T8)

PLASTIC DUAL-IN-LINE PACKAGE

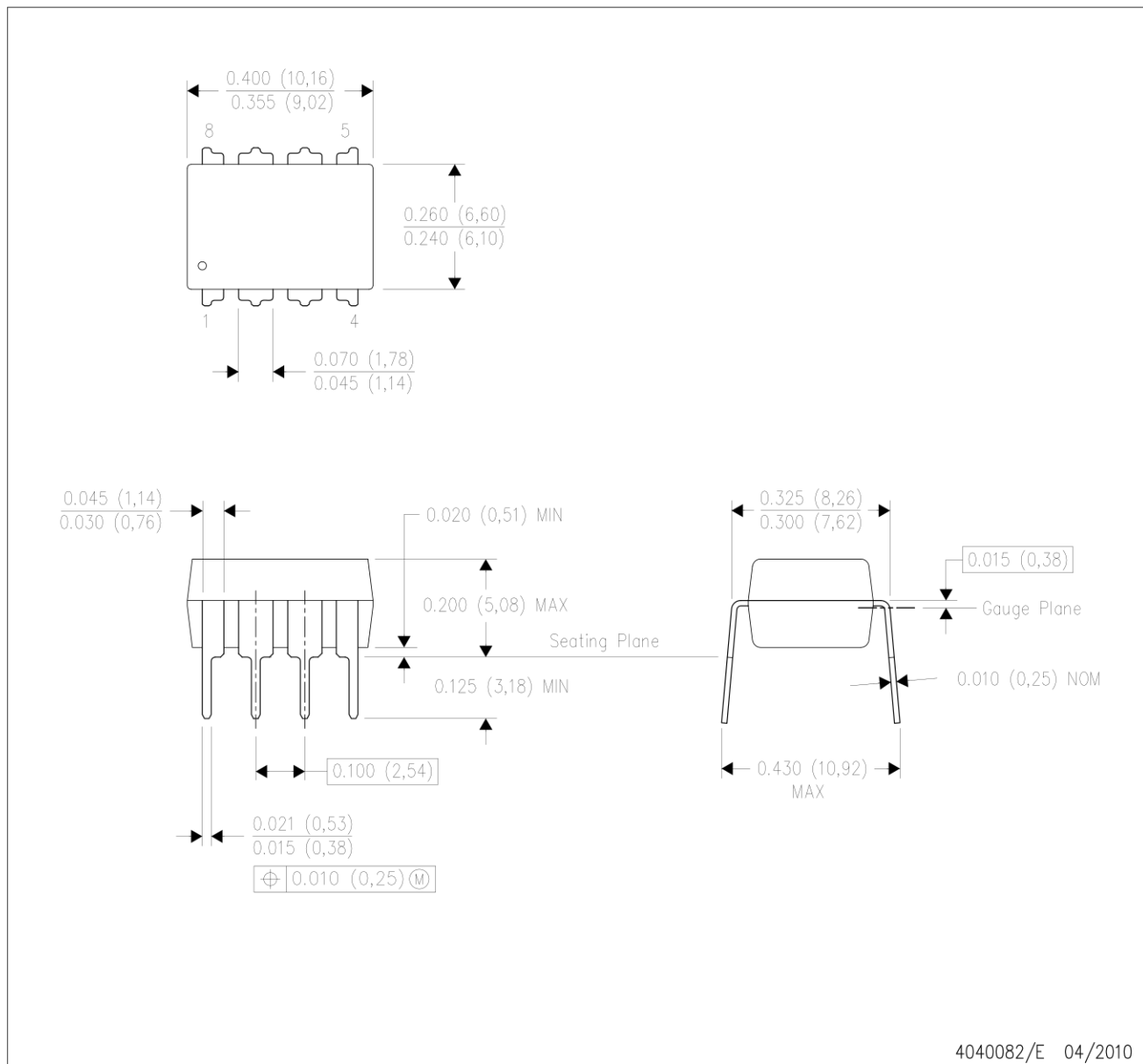

- NOTES:
- A. All linear dimensions are in inches (millimeters).
  - B. This drawing is subject to change without notice.
  - C. Falls within JEDEC MS-001 variation BA.

## IMPORTANT NOTICE AND DISCLAIMER

TI PROVIDES TECHNICAL AND RELIABILITY DATA (INCLUDING DATA SHEETS), DESIGN RESOURCES (INCLUDING REFERENCE DESIGNS), APPLICATION OR OTHER DESIGN ADVICE, WEB TOOLS, SAFETY INFORMATION, AND OTHER RESOURCES "AS IS" AND WITH ALL FAULTS, AND DISCLAIMS ALL WARRANTIES, EXPRESS AND IMPLIED, INCLUDING WITHOUT LIMITATION ANY IMPLIED WARRANTIES OF MERCHANTABILITY, FITNESS FOR A PARTICULAR PURPOSE OR NON-INFRINGEMENT OF THIRD PARTY INTELLECTUAL PROPERTY RIGHTS.

These resources are intended for skilled developers designing with TI products. You are solely responsible for (1) selecting the appropriate TI products for your application, (2) designing, validating and testing your application, and (3) ensuring your application meets applicable standards, and any other safety, security, regulatory or other requirements.

These resources are subject to change without notice. TI grants you permission to use these resources only for development of an application that uses the TI products described in the resource. Other reproduction and display of these resources is prohibited. No license is granted to any other TI intellectual property right or to any third party intellectual property right. TI disclaims responsibility for, and you will fully indemnify TI and its representatives against, any claims, damages, costs, losses, and liabilities arising out of your use of these resources.

TI's products are provided subject to [TI's Terms of Sale](#) or other applicable terms available either on [ti.com](https://www.ti.com) or provided in conjunction with such TI products. TI's provision of these resources does not expand or otherwise alter TI's applicable warranties or warranty disclaimers for TI products.

TI objects to and rejects any additional or different terms you may have proposed. [IMPORTANT NOTICE](#)

Mailing Address: Texas Instruments, Post Office Box 655303, Dallas, Texas 75265  
Copyright © 2022, Texas Instruments Incorporated