

**TOSHIBA**

# **Microcomputer**

**PRODUCT GUIDE**

# The Dawn of the “Computer-on-Silicon” Age



Applications continue to diversify, and devices are becoming more highly integrated. To ensure that your product will be brought to market on time, Toshiba offers a “computer-on-silicon” (COS) solution that combines computer and silicon technologies.

The COS solution is not simply a combination of hardware components plus a basic software library. Rather, COS provides you with total support including extensive services and a line of development systems. This means that you can devote all your efforts to developing your application.

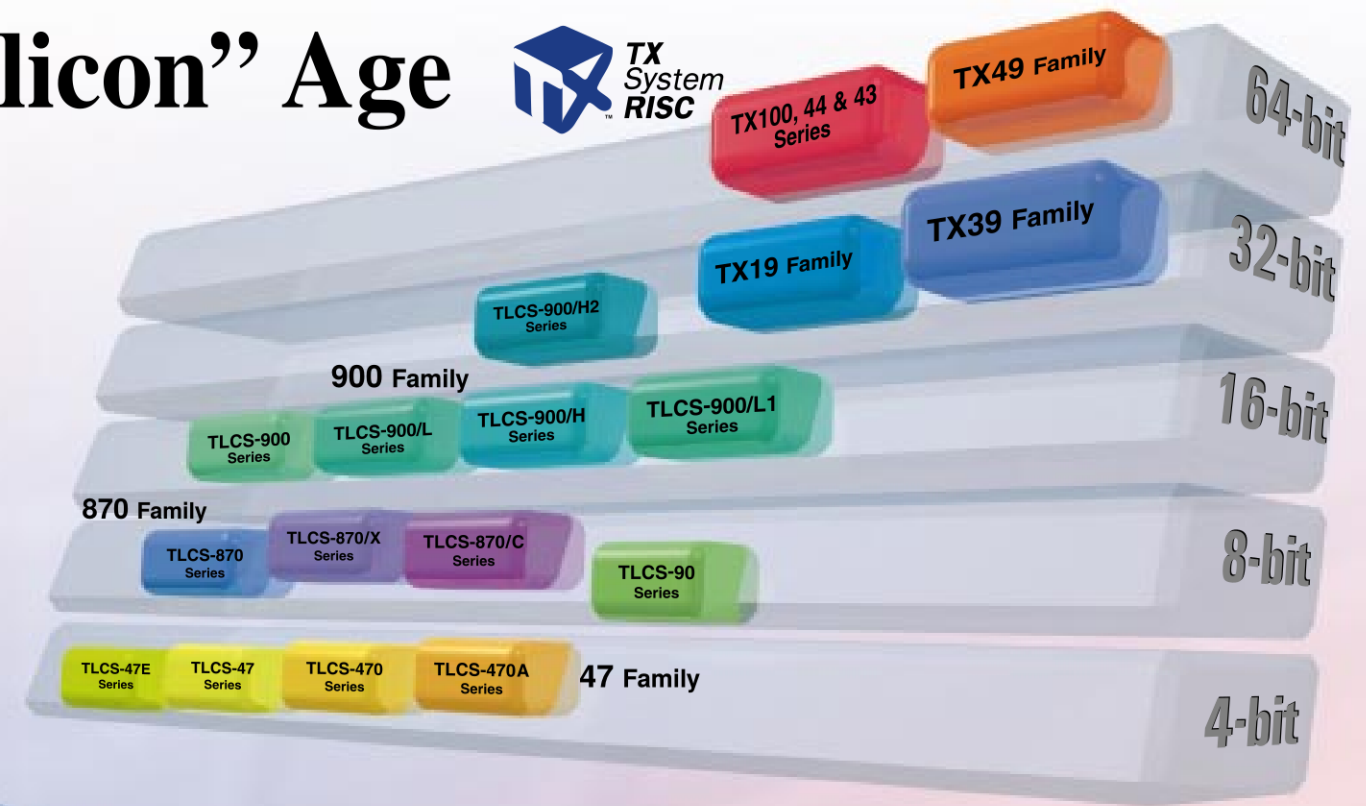
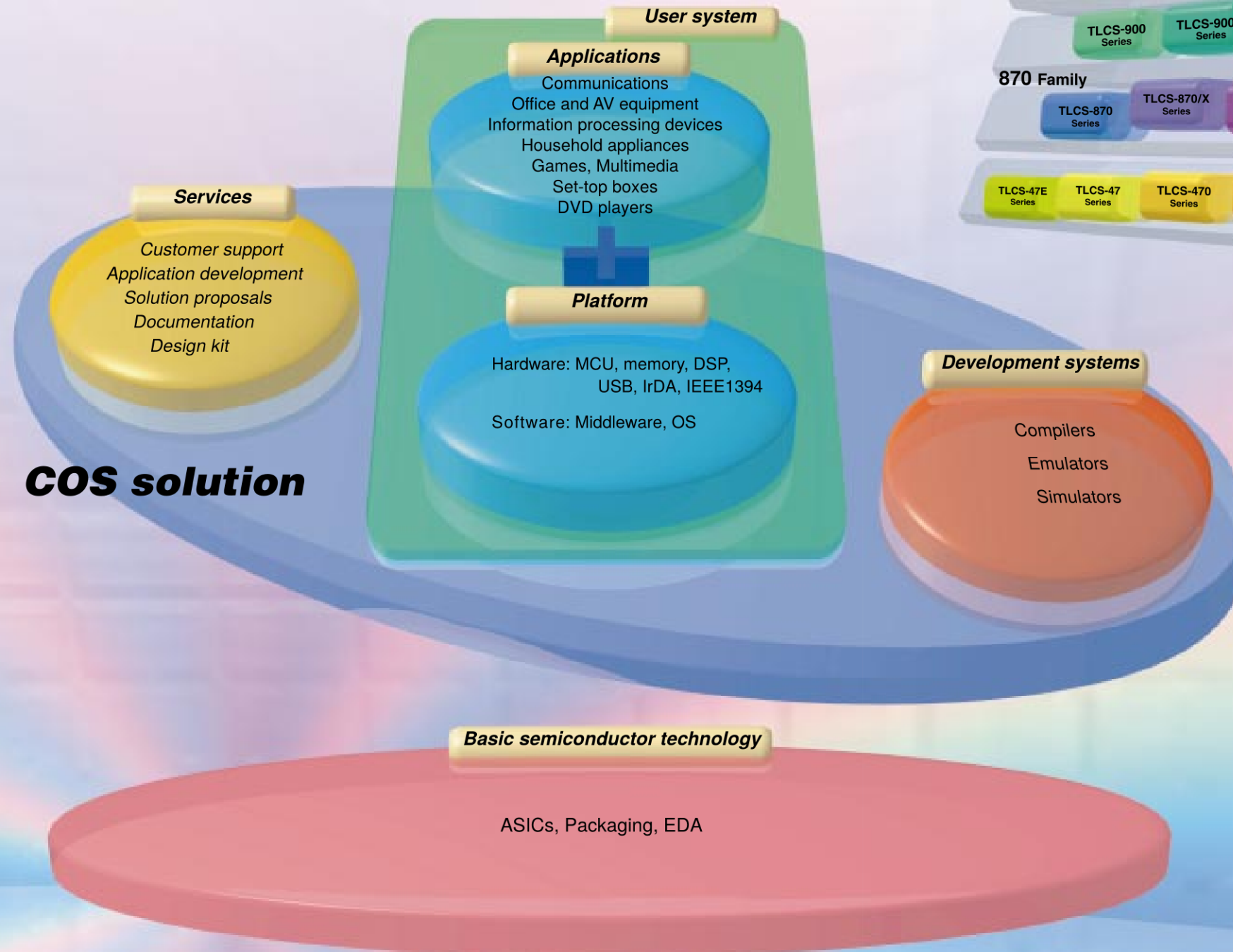

## CONTENTS

<b>RISC</b> .....	4
32-bit TX System RISC	
<b>TX System RISC TX19 Family</b> .....	6
<b>NEW PRODUCTS</b> .....	7
<b>TX System RISC TX39 Family</b> .....	8
<b>NEW PRODUCTS</b> .....	9
64-bit TX System RISC	
<b>TX System RISC TX49 Family</b> .....	12
<b>NEW PRODUCTS</b> .....	13
<b>TX100, TX44 and TX43 Series</b> .....	15
<b>CISC</b> .....	16
<b>Low-pin-count, small-ROM general-purpose microcontrollers</b> .....	17
<b>Microcontrollers with built-in LCD driver</b> .....	18
<b>Microcontrollers with built-in fluorescent display tube driver</b> .....	20
<b>Single-chip TV microcontrollers</b> .....	22
<b>Microcontrollers with built-in AD converter</b> .....	23
<b>16-bit and 32-bit Microcontrollers</b> .....	24
<b>900 Family</b> .....	24
900/L Series.....	25
900/H Series.....	26
900/L1 Series.....	27
900/H2 Series.....	28
<b>900 Family Selection Guide</b> .....	29
<b>NEW PRODUCTS</b> .....	30
<b>8-bit Microcontrollers</b> .....	32
90 Series.....	32
90 Series Selection Guide.....	33
<b>870 Family</b> .....	34
870 Series.....	35
870 Series Selection Guide.....	36
870/C Series.....	38
870/X Series.....	39
<b>NEW PRODUCTS</b> .....	40
<b>4-bit Microcontrollers</b> .....	43
47 Family.....	43
47 Family Selection Guide.....	44
<b>Surface-Mount Package List</b> .....	46
Toshiba Development Tools.....	46
<b>Development Environment</b> .....	47

To meet diverse customer needs, Toshiba provides a wide range of CISC and RISC microcomputers. The product line includes 32-bit and 64-bit TX System RISCs and also features 4-bit to 32-bit original Toshiba microcontrollers. This wide selection allows you to find the best product for your application.

**Microcomputers of the COS age – Proposal for a new COS solution from Toshiba.**



**RISC** stands for **reduced instruction set computer**. By limiting the computer instruction set used, this architecture enables instructions to be executed at high speed. Compared to the conventional **CISC** (complex instruction set computer), its simplified circuit structure offers attractive features such as increased execution speed and reduced power consumption.

Since we introduced the RISC processor technology (pioneered by the MIPS Group in the U.S.A.) into our product line, we at Toshiba have marketed various RISC products, including the **TX39** Family of embedded 32-bit processors, the **TX43** Series of 64-bit processors for office equipment, and the **TX44/TX100** Series of 64-bit processors for high-end workstations. More recently, the **TX19** Family of processors, with part of the instruction set compressed to 16 bits, and the **TX49** Family of 64-bit processors for embedded use have been added to the product line.

■ TX System RISC road map

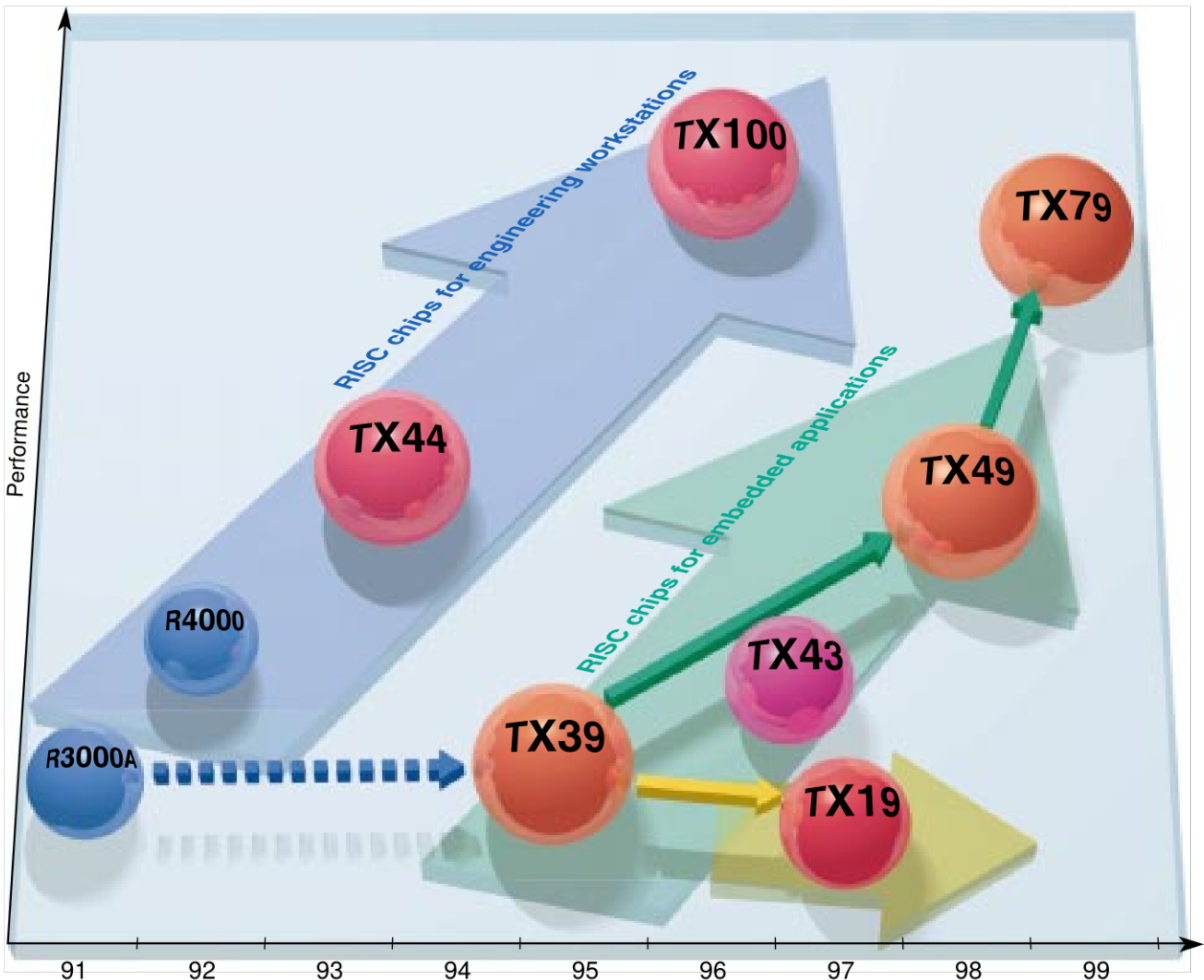

# TX19 Family



The **TX19** Family of RISC microprocessors for embedded-system use is derived from the **TX39** Family that was developed by Toshiba based on the R3000A architecture designed by the MIPS Group in the U.S.A. The **TX19** Family features the MIPS16™ ASE (Application Specific Extension), a highly efficient instruction set from the MIPS Group. The result is a new Toshiba 32-bit RISC processor family.

Future development of the **TX19** Family will focus on products built around the **TX19** processor core; peripheral functions will be incorporated. The **TX19** processor core will also be made available as a CPU core for ASIC (application-specific IC) microcomputers. Hence, the **TX19** Family will offer you the resources necessary to create a system using a single chip.

### High-performance RISC technology

- R3000A architecture
- Processing performance: **21 MIPS**  
(when operating at 20 MHz)  
(Dhrystone 2.1)
- Built-in cache and high-speed memory
- Non-blocking load function  
The instructions which follow the instruction currently being executed are executed while the cache is being refilled.
- DSP function  
A 32-bit multiply/add operation takes four clock cycles to execute.

### Functions suitable for embedded applications

- Code size reduction based on 16-bit codes  
Object code-compatible with MIPS16™ ASE
- Increased real-time capability  
Faster interrupt response  
Instruction/Data cache lock function

### Low power consumption

- Design optimized using low power consumption libraries
- Low power consumption modes  
Clock gear  
Dual clock  
Various standby modes

### Useful as CPU core for gate arrays/cell-based ICs

- TC240 process technology
- Compact core
- Based on Virtual Socket Interface (VSI)
- Complete development environment

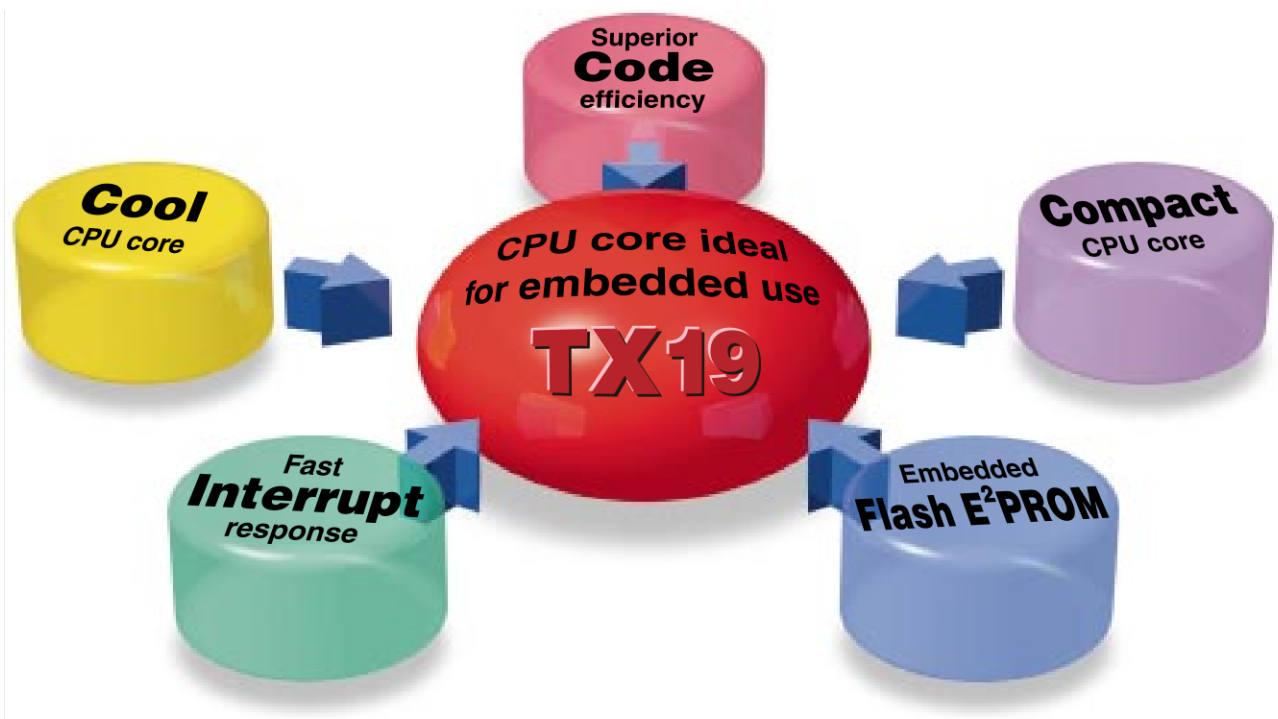

\*R3000A and MIPS16 are trademarks of MIPS Technologies, Inc.

**Core simultaneously realizes low power dissipation and high performance.**

- **Low power dissipation**
  - Design optimized for low power dissipation
  - Clock gear
  - Standby modes
- **Low operating voltage**
- **2.7-V operation possible**

**Twin 16-/32-bit instruction sets improve code efficiency and computing performance.**

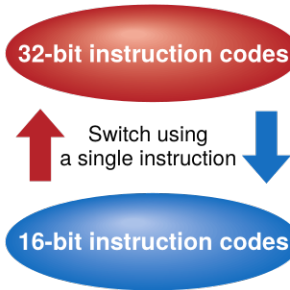

- **Better computing performance**
- **Object code-compatible with TX39**
- **Support for multiply/add operations and coprocessor instructions**
- **Increased code efficiency**
- **Support for PC-relative instructions**

**■ Main applications**

- Portable devices: PCI, personal organizers, digital cellular 'phones
- PC peripherals: HDDs, DVD-ROM, printers
- Home electronics: DVD players, DVCs, DSCs



# NEW PRODUCTS

**Built-in peripheral functions**

**TMP1904AF\***

**NEW**

\*Under development

**■ 32-bit general-purpose RISC microprocessor with peripheral functions**

The **TMP1904AF** is a 32-bit RISC microprocessor built around the **TX19** processor core and incorporating peripheral circuits such as a memory controller, DMAC, UART and timer – all highly suitable for general-purpose use.

This microprocessor can be used for a wide range of applications, from portable information equipment to copiers and other office equipment.

- Instruction cache: 4 Kbytes built in
- Data cache: 1 Kbyte built in
- SRAM/ROM controller: 16-bit bus width can also be set. Page Mode Read supported
- DRAM controller: 16-bit bus width can also be set. Fast Page Mode, Hyper Page Mode
- DMA controller: 2 channels  
Memory-to-memory transfer, memory-to-I/O transfer
- Interrupt controller: 6 external sources
- Timer: 3 channels
- UART: 2 channels
- PIO: 8 bits × 3 ports
- Maximum operating frequency: 20 MHz
- Supply voltage: 2.7 V to 3.6 V
- Package: 160-pin QFP

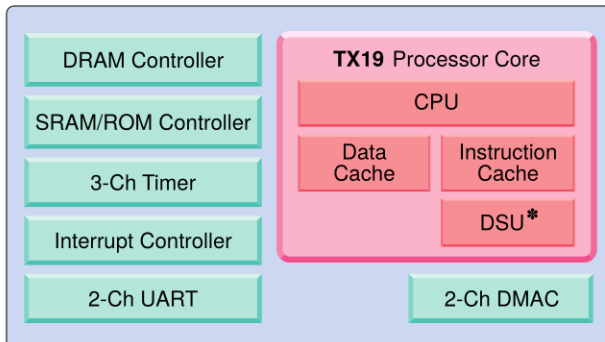

\*DSU: debug support unit

# TX39 Family



The **TX39** Family of embedded-use RISC microprocessors was developed by Toshiba based on the R3000A architecture designed by the MIPS Group, a division of Silicon Graphics, Inc. It is an original Toshiba 32-bit processor family. Using the **TX39** or the high-speed **TX39/H** as the CPU core for gate arrays and cell-based ICs, you can accomplish greater integration in your system.

## High-performance RISC technology

- R3000A architecture
- **TX39/H** processing performance: **74 MIPS**  
(when operating at 20 MHz)
- **TX39** processing performance: **52 MIPS**  
(when operating at 20 MHz)  
(Dhrystone 2.1)
- Built-in cache memory
- Non-blocking load function  
The instructions which follow the instruction currently being executed are executed while the cache is being refilled.
- DSP function  
A 32-bit multiply/add operation takes only a single clock cycle to execute.

## Low power consumption

- Low power consumption modes
- Clock stop function

## Functions suitable for embedded applications

- Reduced code size and improved performance  
Use of **branch-likely** instructions  
Hardware interlock function
- Increased real-time capability  
Cache lock function
- Real-time debugger system connection  
Real-time debugging is possible while cache is on.

## Useful as CPU core for gate arrays/cell-based ICs

- **TX39/H**: **TC220** process technology
- **TX39**: **TC200** process technology
- Complete development environment

# NEW PRODUCTS

## General-purpose MPU

### TMPR3901AF-70

#### ■ 32-bit general-purpose RISC microprocessor based on the TX39/H core

The **TMPR3901AF** is built around the **TX39/H** high-speed core and incorporates peripheral circuits such as a clock generator and a write buffer.

As well as being used as a general-purpose MPU, this microprocessor can also be used to evaluate performance or create function prototypes when ASICs using the **TX39/H** core are being developed.



- Instruction cache: 4 Kbytes built in
- Data cache: 1 Kbyte built in
- Clock generator with ×8 PLL
- 4-stage write buffer
- Half-Speed Bus Mode  
System bus frequency is halved.
- Low power consumption modes  
Doze/Halt Mode to reduce power consumption when idle  
RF function to reduce operating frequency
- Built-in debug support unit
- Maximum operating frequency: 70 MHz
- Supply voltage: 3.3 V
- Package: 160-pin QFP

# NEW PRODUCTS

## Built-in graphics controller

### TMPR3903AF

#### ■ 32-bit RISC microprocessor with graphics controller

The **TMPR3903AF** is a 32-bit RISC microprocessor, incorporating graphics control and other functions suitable for car navigation systems, portable information terminals and other systems that require color displays. In addition, this microprocessor contains a memory controller, DMA controller, SIO, PIO and other peripheral circuits all encapsulated together in a 208-pin QFP package.

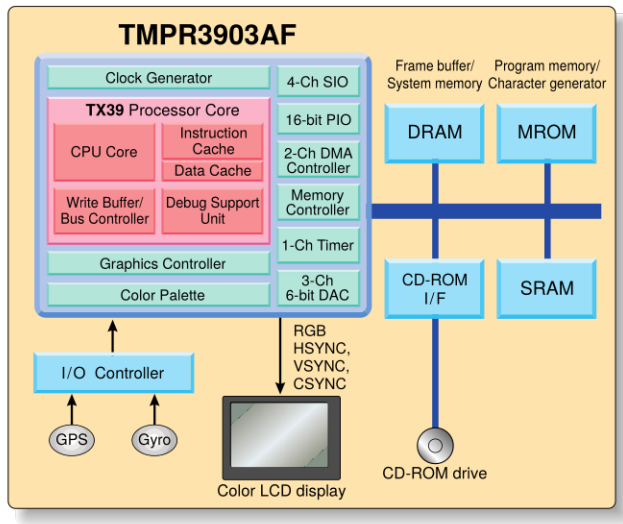

- Instruction cache: 4 Kbytes built in
- Data cache: 1 Kbyte built in
- Clock generator with ×4 PLL
- 4-stage write buffer
- Half-Speed Mode
  - System bus frequency is halved.
- Built-in debug support unit
- Graphics control functions
  - Frame buffer configured using DRAM
  - Fast Page Mode/Hyper Page Mode
  - 4-plane superimposition performed by hardware
  - Display synchronization signals  
HSYNC, VSYNC and CSYNC are generated.
  - Built-in color palette and 3-ch video DAC
- DMA controller: 2 channels
- Interrupt controller: 3 external sources
- SIO: 4 channels; PIO: 16 bits
- Timer (free-running counter)
- Maximum operating frequency: 50 MHz
- Operating temperature range: -40° to 85°C
- Supply voltage: 3.3 V
- Package: 208-pin QFP

## Built-in peripheral functions

### TMPR3904AF-66

#### ■ 32-bit general-purpose RISC microprocessors with peripheral functions

The **TMPR3904AF** is a 32-bit RISC microprocessor built around the **TX39/H** high-speed processor core and incorporating peripheral circuits such as a memory controller, DMA controller, UART and timer – all highly suitable for general-purpose use.

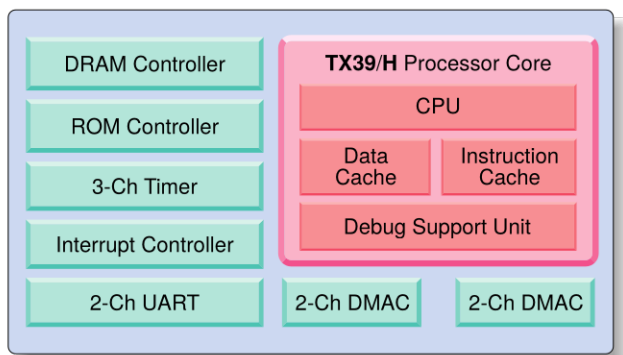

- Instruction cache: 4 Kbytes built in
- Data cache: 1 Kbyte built in
- ROM controller: 16-bit bus width can also be set.
  - Page Mode Read supported
- DRAM controller: 16-bit bus width can also be set.
  - Fast Page Mode, Hyper Page Mode
- DMA controller: 4 channels
  - Memory-to-memory transfer, memory-to-I/O transfer
- Interrupt controller: 8 external sources
- Timer: 3 channels
- UART: 2 channels
- PIO: 8 bits × 3 ports
- Maximum operating frequency: 66 MHz
- Supply voltage: 3.3 V
- Package: 208-pin QFP

# NEW PRODUCTS

## Built-in PCI controller

### TMPR3907F

#### 32-bit RISC microprocessor with PCI controller

The **TMPR3907F** is a 32-bit RISC microprocessor built around the **TX39/H** processor core. It incorporates a PCI controller and other peripheral circuits such as a memory controller, UART and timer.

Using the **TX39/H** high-speed core, this microprocessor operates at 66 MHz, with the PCI bus operating at 33 MHz.

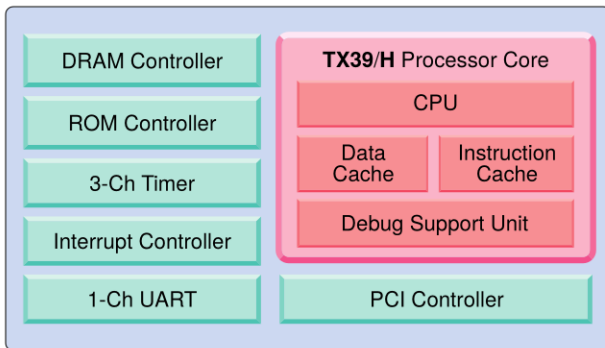

- Instruction cache: 4 Kbytes built in
- Data cache: 1 Kbyte built in
- PCI controller: 3 slots supported
- ROM controller: interleaved operation also possible
- DRAM controller
- Interrupt controller: 3 external sources
- Timer: 3 channels
- UART: 1 channel
- Maximum operating frequency: 66 MHz
- Supply voltage: 3.3 V
- Package: 208-pin QFP

## Built-in peripheral functions

### TMPR3912U

#### 32-bit RISC microprocessor with peripheral functions for portable information equipment

The **TMPR3912U** is an application-specific standard product (ASSP) built around the **TX39/H** processor core and incorporating the peripheral functions required for portable information communicators (PICs) on a single chip. In addition, this microprocessor has an enhanced power management function, making it ideal for PICs. All told, the **TMPR3912U** helps you minimize the size, reduce the cost, and increase the functionality of your portable information terminal system.

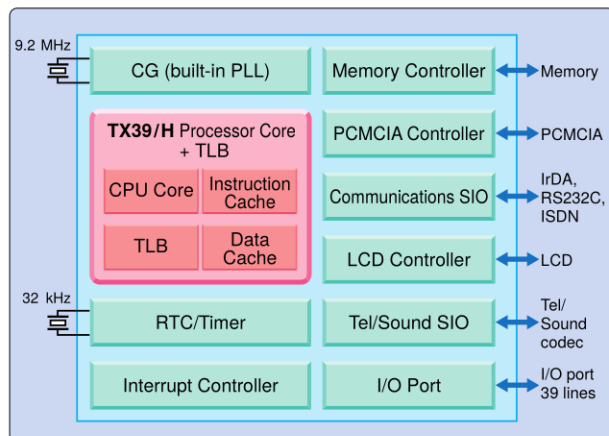

- Instruction cache: 4 Kbytes built in
- Data cache: 1 Kbyte built in
- Memory management unit (TLB): 32-entry, 4-Kbyte pages
- Memory controller: supports DRAM (EDO), SDRAM, SRAM, ROM and flash memory.
- Communications interface: supports RS232C, IrDA (rev 1.0) and ISDN.
- PCMCIA interface
- LCD interface: supports monochrome and color. 1024 × 1024 pixels maximum
- Timer: 2 channels (RTC and/or watchdog timer)
- I/O port: 39 bits
- Low power consumption modes: Doze/Sleep
- Maximum operating frequency: 75 MHz
- Supply voltage: 3.3 V
- Package: 208-pin LQFP (1.4 mm thick)



# NEW PRODUCTS

Built-in peripheral functions

**NEW**

## TMPR3922U\*/AU\*

\*Under development

### ■ 32-bit RISC microprocessor with peripheral functions for high performance

The **TMPR3922U** is an application-specific standard product (ASSP) built around the **TX3920** processor core and incorporating the peripheral functions required for portable information communicators (PICs) on a single chip. In addition, this microprocessor has an enhanced power management function, making it ideal for PICs. All told, the **TMPR3922U** helps you minimize the size, reduce the cost, and increase the functionality of your portable information terminal system or multimedia device.

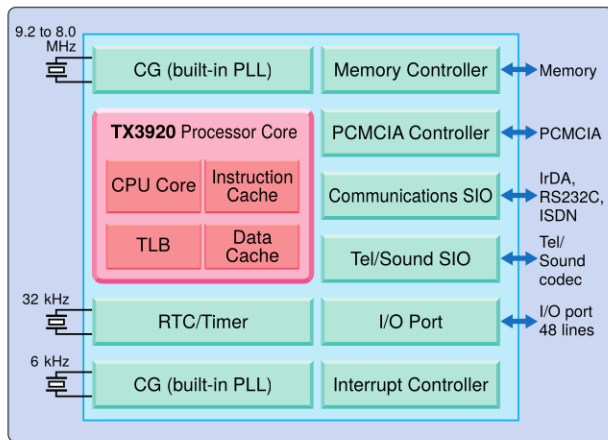

- Instruction cache: 16 Kbytes built in (2-way set-associative)
- Data cache: 8 Kbytes built in (2-way set-associative)
- Memory management unit (TLB): 64-entry 4-Kbyte/16-Kbyte/64-Kbyte/256-Kbyte/1-Mbyte/4-Mbyte pages
- Memory controller: supports DRAM (EDO), SDRAM, SRAM, ROM and flash memory.
- Communications interface: supports RS232C, IrDA (rev 1.1) and ISDN.
- PCMCIA interface
- Timer: 2 channels, watchdog timer
- RTC
- I/O port: 48 pins
- Low power dissipation modes: Sleep (only RTC operates.) Doze (device operates at low frequency.)
- Maximum operating frequency: 148 MHz / 129 MHz
- I/O supply voltage: 3.3 V
- Internal supply voltage: 2.5 V
- Package: 208-pin LQFP (1.4 mm thick)

### ■ Advanced PIC system solution

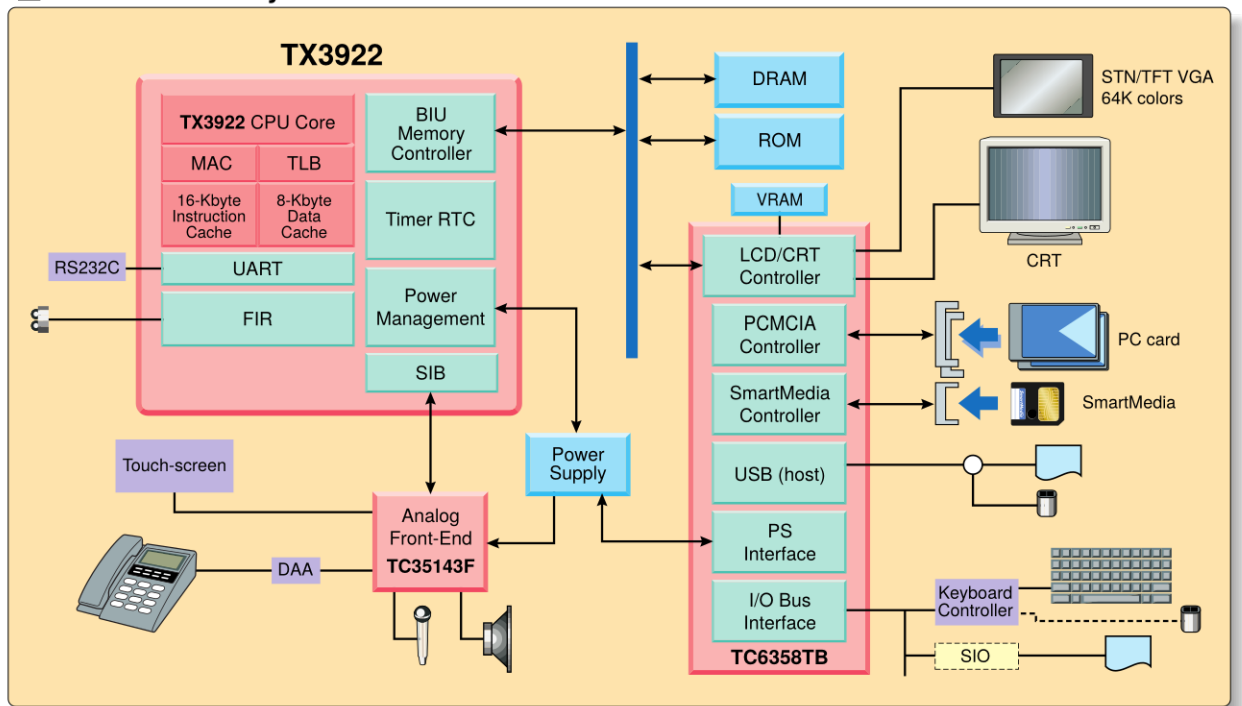

# TX49 Family



The **TX49** Family of RISC microprocessors for embedded use is an original Toshiba 64-bit processor family and is based on the RISC architecture designed by the MIPS Group in the U.S.A. The **TX49** Family processors can also be used as ASSPs or as the CPU core for gate arrays and cell-based ICs, allowing you to attain a higher level of integration in your system than has ever been possible before.

### 64-bit RISC architecture

- 64-bit operation
- Thirty-two 64-bit general-purpose registers
- Optimized 5-stage pipelining
- Upward-compatible instruction set including MIPS I, MIPS II and MIPS III instruction set architectures (ISAs)
  - Multiply/add instructions and debugging instructions added
- Built-in 48 double-entry TLB

### Built-in high-capacity primary cache

- Instruction cache: 8/16/32 KB (selectable)
  - 4-way set-associative
  - Supports lock function.
- Data cache: 8/16/32 KB (selectable)
  - 4-way set-associative
  - Supports lock function.
  - Write-back/write-through (every page)
  - Supports snoop function.

### Numerous optional functions

- Debug support unit
  - Supports EJTAG.
- Single- or double-precision floating-point unit

### Low power consumption design

- Low power consumption modes (Doze/Halt)
- Supply voltage: 3.3 V

## ■ TX49 processor block diagram

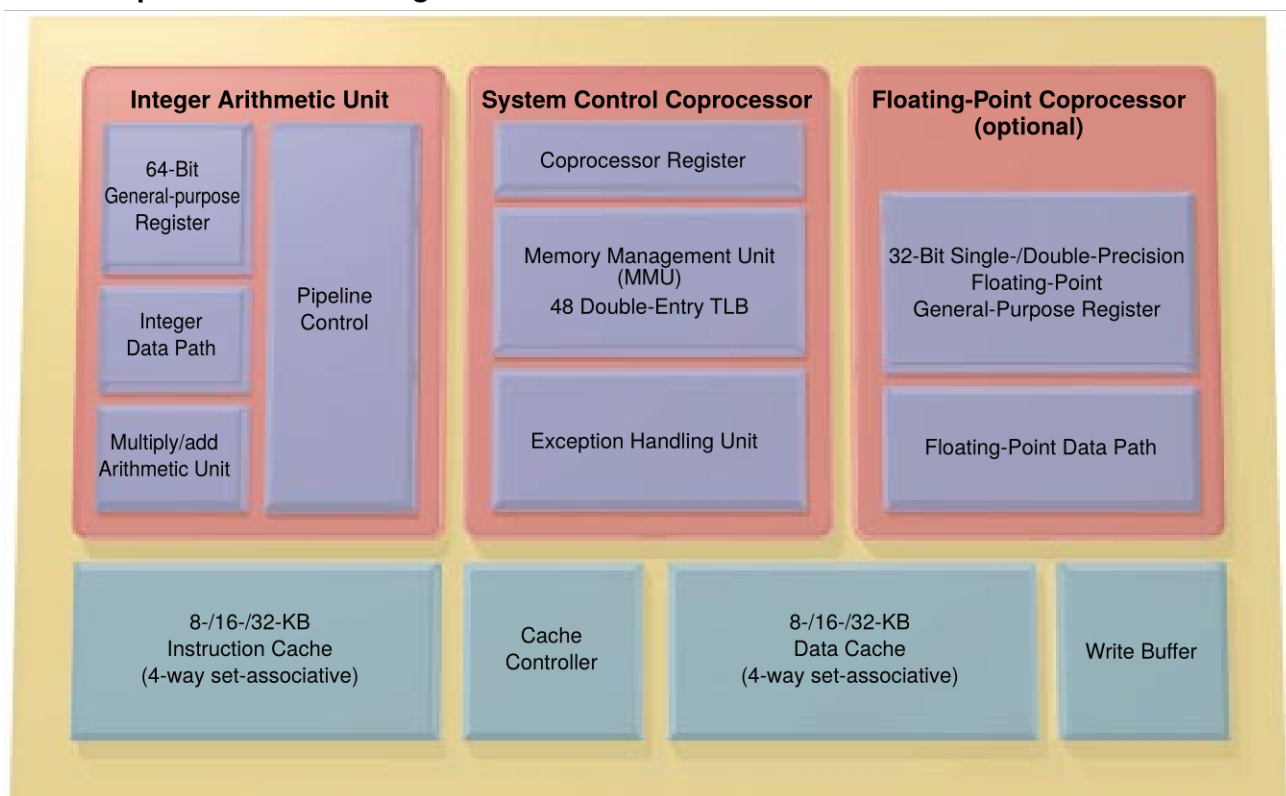

# NEW PRODUCTS

General-purpose MPU

**NEW**

## TMPR4901F-133\*

\*Under development

### ■ 64-bit general-purpose RISC microprocessor based on the TX49 processor core

The **TMPR4901F** is the first product in the **TX49** Family. Built around the **TX49** processor core, it incorporates a clock generator and a debug support unit. This microprocessor is not just a general-purpose MPU, it can also be used to verify functions and evaluate device performance during the development of ASICs which feature the **TX49** processor core.

- TX49 processor core
- Instruction cache: 16 Kbytes built in
- Data cache: 16 Kbytes built in
- Separate 36-bit address bus and 64-bit data bus
- Clock generator with ×16 PLL
- Low power consumption modes (Doze/Halt)
- Built-in debug support unit
- Maximum Internal operating frequency: 133 MHz
- Maximum external operating frequency: 66 MHz
- Supply voltage: 3.3 V
- Package: 208-pin QFP

### ■ TMPR4901F block diagram

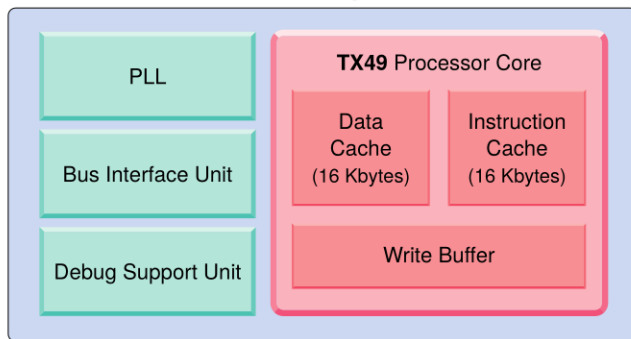

### ■ System block diagram

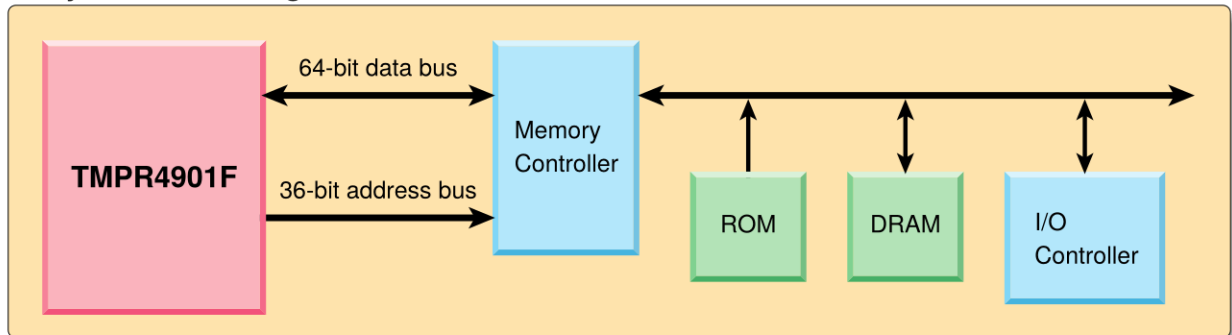

### ■ Target applications

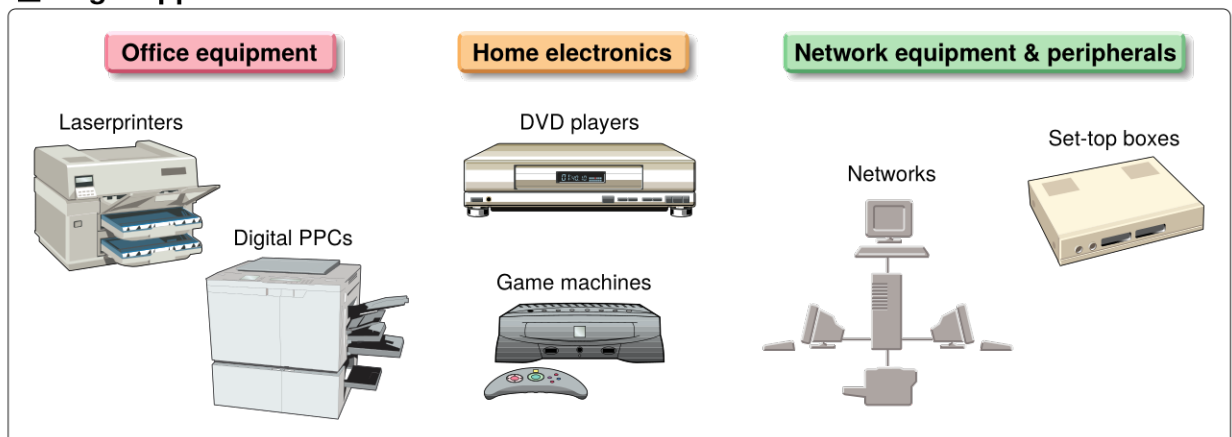

# NEW PRODUCTS

General-purpose MPU

NEW

## TMPR4951F-133\*

\* Under development

### ■ 64-bit general-purpose RISC microprocessor based on the TX49 processor core

Built around the **TX49** processor core, the **TMPR4951F** incorporates a SysAD bus interface function. This microprocessor is not just a general-purpose MPU, it can also be used as a base for future products incorporating a SysAD bus interface function. The device is also pin-compatible with our existing **TC86R4300** microprocessor. The high-capacity 4-way set-associative caches enable the device to meet demands for improved performance and high-speed processing.

- 64-bit **TX49** core
- Instruction cache: 16 Kbytes built in
- Data cache: 16 Kbytes built in
- 32-bit system interface (SysAD bus interface)
- Support for JTAG
- Supply voltage: 3.3 V
- Maximum internal operating frequency: 133 MHz
- Maximum external operating frequency: 66 MHz
- Power dissipation : 1.2 W (at 133 MHz)
- Package: 120-pin QFP

### ■ TMPR4951F block diagram

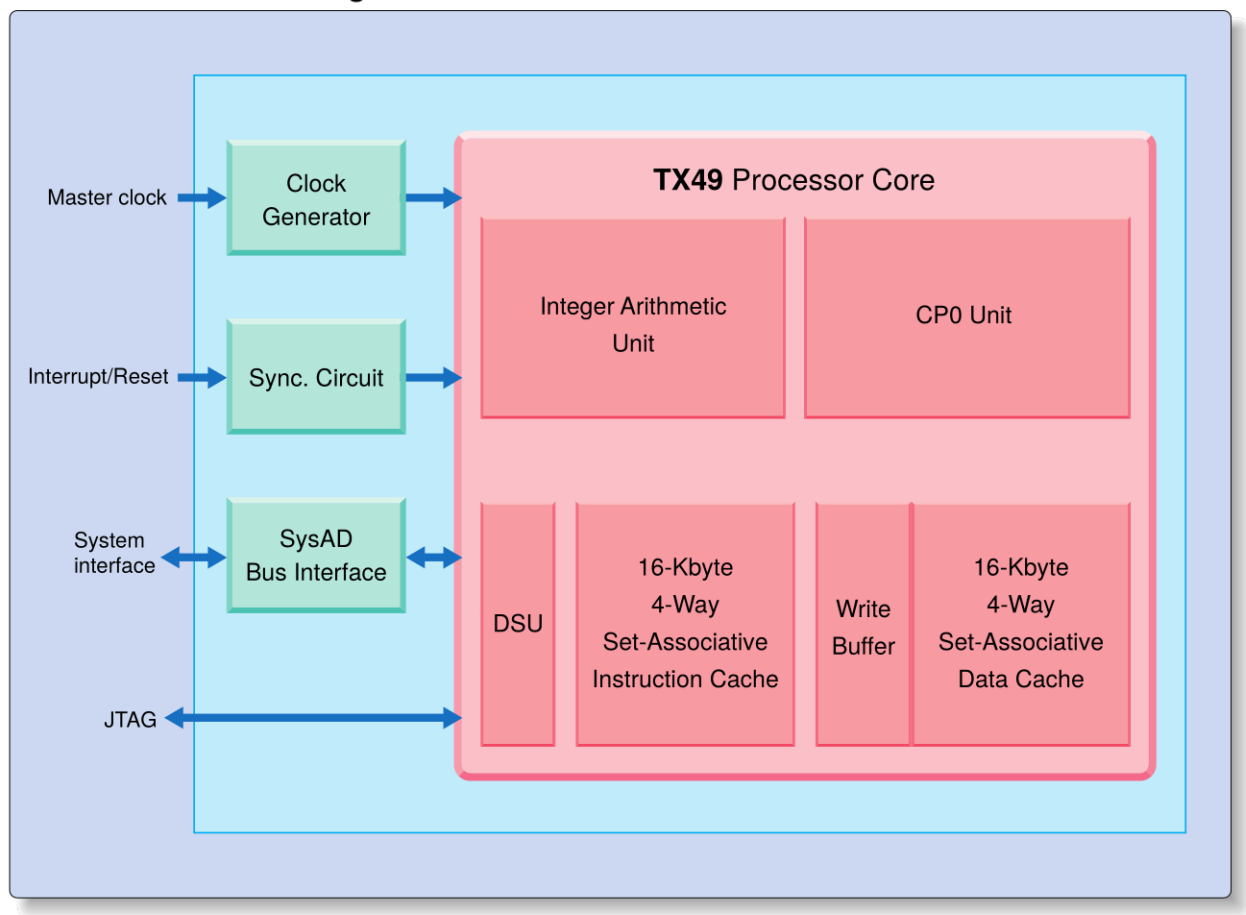

## 64-Bit TX System RISC

# TX100 Series



### 64-bit superscalar RISC processors for workstations and servers

- Compatible with the R10000 RISC processors available from MIPS Technologies, Inc.
- 64-bit superscalar architecture
- Capable of operating at 200 MHz
- Built-in 32-Kbyte instruction and data caches



Product No.	Internal Frequency	Supply Voltage	Package	Features
<b>TC86R10000</b>	200 MHz	3.3 V	LGA 599	Superscalar architecture Built-in primary cache memory (64 KB) Built-in secondary cache memory controller

## 64-Bit TX System RISC

# TX44 Series



The **TX44** Series is comprised of 64-bit RISC microprocessors that are compatible with the R4000/R4400 microprocessors from MIPS Technologies, Inc. The microprocessors in this series are suited to a wide variety of applications, ranging from personal computers to high-end workstations. In addition to the internal operating frequency of 200 MHz, 8-stage super-pipeline and 32 Kbytes of primary cache memory, the microprocessors in this series contain an FPU based on the ANSI/IEEE-754-1985 standard, enhancing their integer and floating-point arithmetic capability.



- Integer arithmetic performance: 141 SPECint92 (at 200 MHz)
- Floating-point arithmetic performance: 143 SPECfp92 (at 200 MHz)
- 8-stage super-pipeline
- Built-in secondary cache memory controller
- Multiprocessing capability
- Package: 447-pin PGA

Product No.	Internal Frequency	Supply Voltage	Operating Temperature Range	Package
<b>TC86R4400-200(L)</b>	200 MHz	3.3 V	0° to 70°C	PGA447
<b>TC86R4400-200(SB)</b>	200 MHz	3.3 V	0° to 85°C	PGA447
<b>TC86R4400-150(S)</b>	150 MHz	3.3 V	0° to 85°C	PGA447

## 64-Bit TX System RISC

# TX43 Series



Product No.	Internal Frequency	Supply Voltage	Operating Temperature Range	Package
<b>TC86R4300F-100</b>	100 MHz	3.3 V	0° to 85°C	QFP120

## Small package general-purpose microcontrollers



In addition to the SOP and SSOP, Toshiba offer a line-up of 10 mm × 10 mm 44-pin and 64-pin miniflat packages. Some products incorporate functions such as a built-in 8-bit AD converter.

### Applications

- Home electronics
- Audio
- Remote control
- Game machines
- Portable devices
- VCRs
- Telephones
- Battery chargers

		In mass production	Under development	Low-pin-count, small-ROM, general-purpose microcontrollers							
32 KB									TMP87CM48	TMP87CM41	
24 KB									TMP87CK41		
16 KB									TMP87CH48	TMP87CH41	
12 KB									TMP86CH06	TMP87CC41	
8 KB									TMP87C808	TMP87C809	
4 KB									TMP87C405A	TMP87C409	
2 KB									TMP87C408	TMP47C443	
1 KB									TMP47E487	TMP47E486	
									TMP47C408D	TMP47C443D	
									TMP47C201	TMP47C206	
									TMP47C202	TMP47C203	
									TMP47C241	TMP47C243	
									TMP47C243D		
									TMP47C101	TMP47E186	
									TMP47E187	TMP47C102	
										TMP47C103	
		SOP			SSOP		μQFP				
		16-pin		20-pin		28-pin		30-pin		44-pin 64-pin	

### ● 8-bit microcontrollers (870 Series, 870/C Series)

Series Name	Product No.	ROM (bytes)	RAM (bytes)	I/O	Small Package	Additional Functions	Version with Built-in OTP			
870	TMP87C405AM	4K	256	22	SOP28	● Clock gear	TMP87P808M			
	TMP87C408M	4K				● 8-bit AD converter: 6 channels				
	TMP87C808M	8K				● Clock gear	TMP87P808LM			
	TMP87C408LM	4K				● 8-bit SIO: 1 channel				
	TMP87C808LM	8K								
	TMP87C409M	4K					TMP87P809M			
	TMP87C809M	8K				● 10-bit AD converter: 8 channels				
	TMP87C408DM	4K				● 8-bit SIO/I <sup>2</sup> C bus: 1 channel (selectable by software)				
	TMP87C807U	8K				512	37	μQFP44 (10 × 10 mm)	● 8-bit AD converter: 6 channels ● 8-bit SIO: 1 channel	TMP87P808M
	TMP87C847U	4K							● 8-bit SIO: 1 channel, high-speed serial output	
	TMP87C847U	8K	● 8-bit AD converter: 8 channels	TMP87PH47U						
	TMP87CH47U	16K	● 8-bit SIO: 1 channel, high-speed serial output							
	TMP87C847LU	8K	● 16-bit timer/counter: 2 channels	TMP87PH47LU						
	TMP87CH47LU	16K	8-bit timer/counter: 2 channels							
	TMP87C841U	8K	256		56				μQFP64 (10 × 10 mm)	● 10-bit AD converter: 16 channels
	TMP87CC41U	12K	512	● 8-bit SIO: 2 channels						
	TMP87CH41U	16K	1K	● 16-bit timer/counter: 2 channels						
TMP87CK41U	24K	1K	8-bit timer/counter: 2 channels							
TMP87CM41U	32K	1K								
TMP87CH48U	16K	512				● 10-bit AD converter: 16 channels ● UART ● I <sup>2</sup> C bus	TMP87PH48U			
*TMP87CM48U	32K	1K					TMP87PM48U			
870/C	*TMP86CH06U	16K	512	35		μQFP44 (10 × 10 mm)	● UART: 2 channels ● SIO: 1 channel (switchable)	*TMP86PH06U		

†For details of the products listed above, please refer to the 870 Series Selection Guide on pages 36 and 37, or the 870/C Series Selection Guide on page 38.

\* Under development

### ● 4-bit microcontrollers (47E Series)

Series Name	Product No.	ROM (bytes)	RAM (nibbles)	I/O	Small Package	Additional Functions	Version with Built-in OTP
47E	TMP47C101M	1K	64	11	SOP16	● High-current output port: 4 pins	TMP47P201VP
	TMP47C201M	2K	128			● 16-byte E <sup>2</sup> PROM built in	
	TMP47E186M	1K	64				
	TMP47E187M	1K	64				
	TMP47C102M	1K	64	15	SOP20	● High-current output port: 4 pins	TMP47P202VM
	TMP47C202M	2K	128			● Pulse output: buzzer drive, remote transmission	
	TMP47C103M	1K	64	23	SOP28	● High-current output port: 8 pins	TMP47P403VM
	TMP47C203M	2K	128			● 8-bit SIO: 1 channel	
	TMP47C241M	2K	128	21	SOP28	● 8-bit AD converter: 4 channels	TMP47P241VM
	TMP47C241IM	2K	128			● 4-bit SIO: 1 channel	
	TMP47C241WM	2K	128				
	TMP47C243M	2K	256	23	SOP28	● 8-bit AD converter: 8 channels ● 8-bit SIO: 1 channel	TMP47P443VM
	TMP47C443M	2K	256			● Pulse output: buzzer drive, remote transmission	
	TMP47E486M	4K	256	21	SOP28	● 64-byte E <sup>2</sup> PROM built in	*TMP47W486M
	TMP47E487M	4K	256				*TMP47W487M
	TMP47C243DM	2K	128	23	SSOP30	● 8-bit AD converter: 8 channels ● 8-bit SIO: 1 channel	TMP47P443VDM
	TMP47C443DM	4K	256			● Pulse output: buzzer drive, remote transmission	

†For details of the products listed above, please refer to the 47 Family Selection Guide on pages 44 and 45.

\* Under development

## Microcontrollers with built-in LCD driver

The following microcontrollers contain LCD driver circuitry which incorporates a voltage booster, enabling it to continue to drive the LCD, even at a low operating voltage, and to dissipate little power during operation.

### Applications

- Home electronics
- Audio
- Remote control
- Telephones
- Game machines

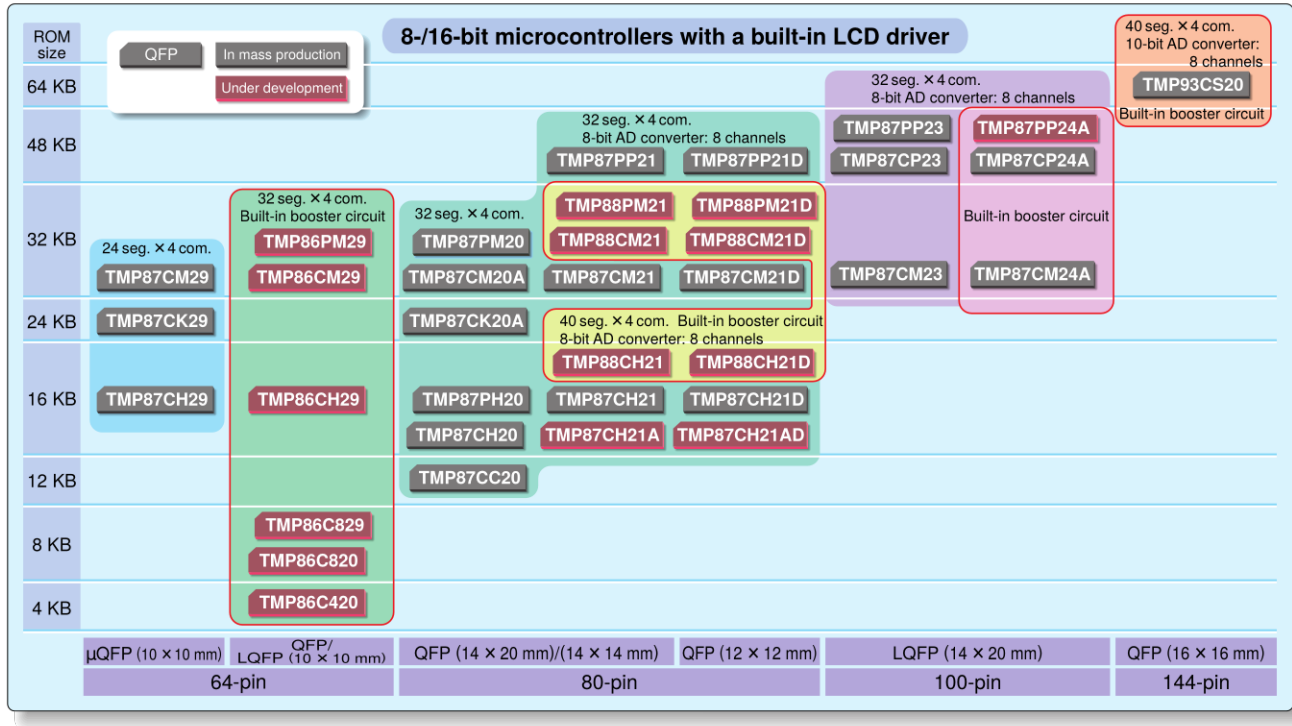

### ● 16-bit microcontroller (900/L Series)

Series Name	Product No.	ROM (bytes)	RAM (bytes)	I/O	LCD Driver	Additional Functions	Supply Voltage (V)	Version with Built-in OTP	Package
900/L	TMP93CS20F	64K	2K	88	40 seg. x 4 com. (built-in booster circuit)	<ul style="list-style-type: none"> <li>● Serial interface: 3 channels</li> <li>● 10-bit AD converter: 8 channels</li> <li>● 16-bit timer/counter: 4 channels</li> <li>● 8-bit timer/counter: 4 channels</li> </ul>	5 ±10% 3 ±10%	●	QFP144 (16 x 16 mm)

† For details of the products listed above, please refer to the 900 Family Selection Guide on page 29.

### ● 8-bit microcontrollers (870 Series, 870/X Series, 870/C Series)

Series Name	Product No.	ROM (bytes)	RAM (bytes)	I/O	LCD Driver	Additional Functions	Supply Voltage (V)	Version with Built-in OTP	Packages
870	TMP87CC20F	12K	512	45	32 seg. x 4 com.	<ul style="list-style-type: none"> <li>● 8-bit SIO: 1 channel</li> <li>● 16-bit timer/counter: 1 channel</li> <li>● 8-bit timer/counter: 4 channels</li> </ul>	4.5 to 6.0 2.7 to 6.0	●	QFP80
	TMP87CH20F	16K							
	TMP87CK20AF	24K							
	TMP87CM20AF	32K	1K	52	32 seg. x 4 com.	<ul style="list-style-type: none"> <li>● 8-bit AD converter: 8 channels</li> <li>● 8-bit SIO: 2 channels</li> <li>● 16-bit timer/counter: 2 channels</li> <li>● 8-bit timer/counter: 2 channels</li> </ul>	4.5 to 5.5 2.7 to 5.5	●	QFP80/ QFP80 (12 x 12 mm)
	TMP87CH21F/DF	16K							
	*TMP87CH21AF/ADF	32K	1K	70	40 seg. x 4 com.	<ul style="list-style-type: none"> <li>● 16-bit timer/counter: 2 channels</li> <li>● 8-bit timer/counter: 2 channels</li> </ul>	4.5 to 5.5 2.2 to 5.5	●	QFP100
	TMP87CM21F/DF	32K							
	TMP87CM23F	32K	1K	43	24 seg. x 4 com.	<ul style="list-style-type: none"> <li>● 8-bit AD converter: 5 channels</li> <li>● UART: 1 channel</li> <li>● 16-bit timer/counter: 1 channel</li> <li>● 8-bit timer/counter: 4 channels</li> </ul>	4.5 to 5.5 2.7 to 5.5	●	SDIP64/ μQFP64 (10 x 10 mm)
	TMP87CM24AF	48K							
	TMP87CP23F	48K	2K	39	32 seg. x 4 com. (built-in booster circuit)	<ul style="list-style-type: none"> <li>● 8-bit AD converter: 8 channels</li> <li>● 8-bit SIO: 1 channel</li> <li>● 18-bit timer/counter: 1 channel</li> <li>● 8-bit timer/counter: 2 channels</li> </ul>	1.8 to 5.5	●	μQFP64 (10 x 10 mm)/ LQFP64
TMP87CP24AF	48K								
TMP87CH29N/U	16K	256	39	32 seg. x 4 com. (built-in booster circuit)	<ul style="list-style-type: none"> <li>● 10-bit AD converter: 8 channels</li> <li>● 8-bit SIO/UART: 1 channel</li> <li>● 16-bit timer/counter: 1 channel</li> <li>● 8-bit timer/counter: 4 channels</li> </ul>	1.8 to 5.5	●	μQFP64 (10 x 10 mm)/ LQFP64	
TMP87CK29N/U	24K								
TMP87CM29N/U	32K								
*TMP88CH21F/DF	16K								
870/X	*TMP88CM21F/DF	32K	1K	47	40 seg. x 4 com.	<ul style="list-style-type: none"> <li>● 8-bit AD converter: 8 channels</li> <li>● 8-bit SIO/UART: 1 channel</li> <li>● 16-bit timer/counter: 2 channels</li> <li>● 8-bit timer/counter: 2 channels</li> </ul>	4.5 to 5.5 2.7 to 4.5	●	QFP80/ LQFP80 (12 x 12 mm)
870/C	*TMP86C420U/F	4K	256	39	32 seg. x 4 com. (built-in booster circuit)	<ul style="list-style-type: none"> <li>● 8-bit AD converter: 8 channels</li> <li>● 8-bit SIO: 1 channel</li> <li>● 18-bit timer/counter: 1 channel</li> <li>● 8-bit timer/counter: 2 channels</li> </ul>	1.8 to 5.5	●	μQFP64 (10 x 10 mm)/ LQFP64
	*TMP88C820U/F	8K							
	*TMP86C829U/F	8K							
	*TMP86CH29U/F	16K							
	*TMP86CM29U/F	32K							

† For details of the products listed above, please refer to the 870 Series Selection Guide on pages 36 and 37, the 870/C Series Selection Guide on page 38, or the 870/X Series Selection Guide on page 39.

\* Under development

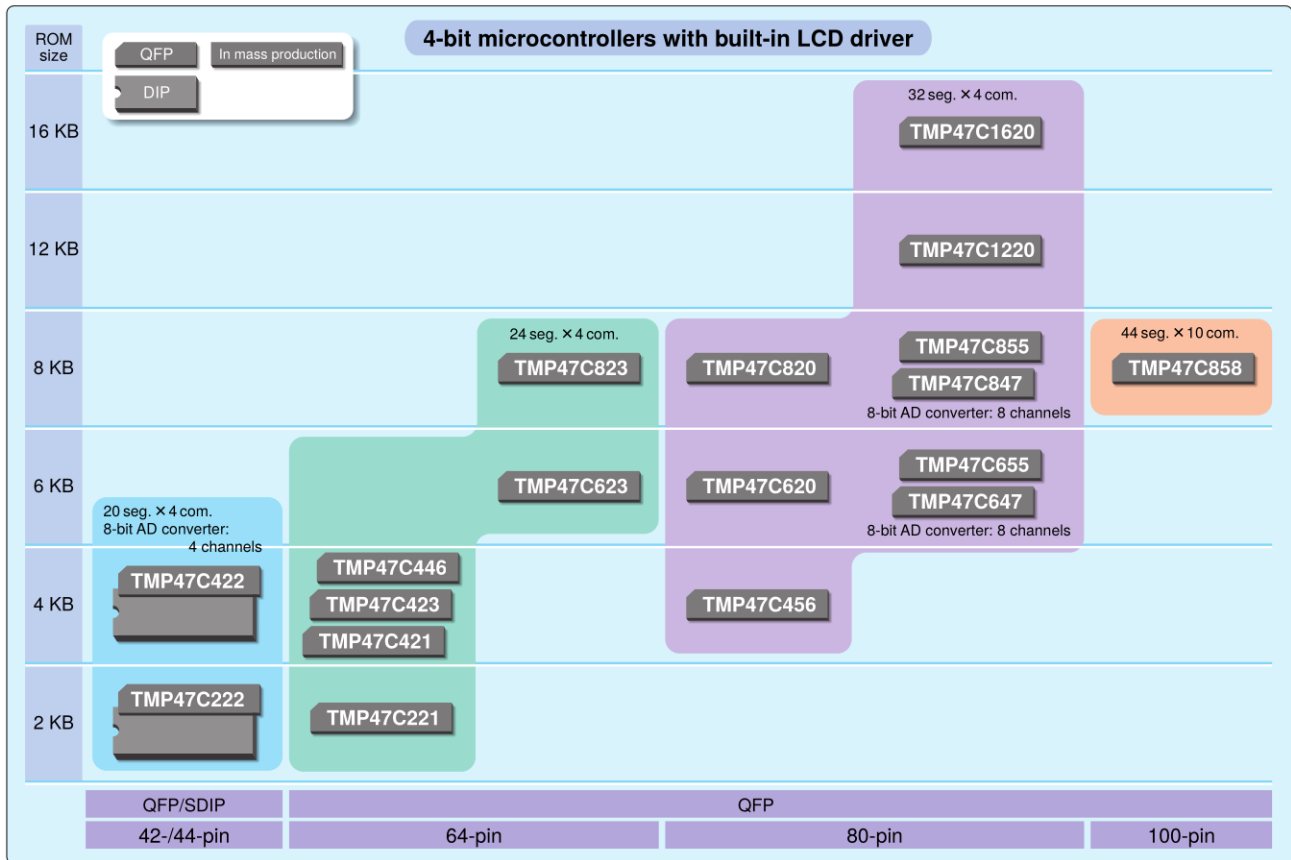

### ● 4-bit microcontroller (47 Family)

Series Name	Product No.	ROM (bytes)	RAM (nibbles)	I/O	LCD Driver	Additional Functions	Supply Voltage (V)	Version with Built-in OTP	Packages
47E	TMP47C222N/F	2K	192	22	20 seg. × 4 com.	• 8-bit AD converter: 4 channels • 8-bit SIO: 1 channel • Pulse output: remote control transmission carrier	2.5 to 5.5	●	SDIP42/ QFP44
	TMP47C422N/F	4K	256						
47	TMP47C221ADF	2K	192	28	24 seg. × 4 com.	• 4-bit SIO: 1 channel • 12-bit timer/counter: 2 channels	4.5 to 6.0	●	QFP64
	TMP47C421ADF	4K	256						
	TMP47C423ADF			24	• 4-bit SIO: 1 channel • Pulse output • 16-bit high-speed event counter: 1 channel	4.5 to 6.0	-	QFP64	
	TMP47C446ADF			34					
	TMP47C456ADF	768	34		• DTMF generator	2.7 to 6.0	-	QFP100	
470	TMP47C620DF	6K	384	36	32 seg. × 4 com.	• 8-bit SIO: 1 channel • Pulse output • 8-bit high-speed event counter: 2 channels	4.5 to 6.0	●	QFP80
	TMP47C820DF	8K	512						
	TMP47C647F	6K	384	35	32 seg. × 4 com.	• 8-bit AD converter: 8 channels • 8-bit SIO: 1 channel • Pulse output	4.5 to 6.0	●	QFP80
	TMP47C847F	8K	512						
	TMP47C655F	6K	896	36	32 seg. × 4 com.	• DTMF generator • 8-bit SIO: 1 channel • Pulse output	2.2 to 6.0	●	QFP80
	TMP47C855F	8K	1024						
	TMP47C858F		512	36	44 seg. × 10 com.	• DTMF generator	2.7 to 6.0	-	QFP100
470A	TMP47C623F	6K	384	32 to 28	24 seg. × 4 com.	• 8-bit SIO: 1 channel • Pulse output • 16-bit high-speed event counter: 1 channel	4.5 to 6.0	●	QFP64
	TMP47C823F	8K	512						
	TMP47C1220F	12K	768	36	32 seg. × 4 com.	• 8-bit SIO: 1 channel • Pulse output • 8-bit high-speed event counter: 2 channels	4.5 to 6.0	●	QFP80
	TMP47C1620F	16K							

†For details of the products listed above, please refer to the 47 Family Selection Guide on pages 45 and 46.



# CISC APPLICATIONS

## Microcontrollers with built-in fluorescent display tube drivers

The following microcontrollers incorporate a display circuit with high breakdown voltage output which can automatically transfer display data to a port so as to drive a fluorescent display tube directly. In addition to existing products, such as a VFT driver circuit which can display digits on a segmented display, Toshiba offer a line-up of products which support automatic display to universal grid display tubes.

### Applications

- Home electronics
- Audio
- VCRs

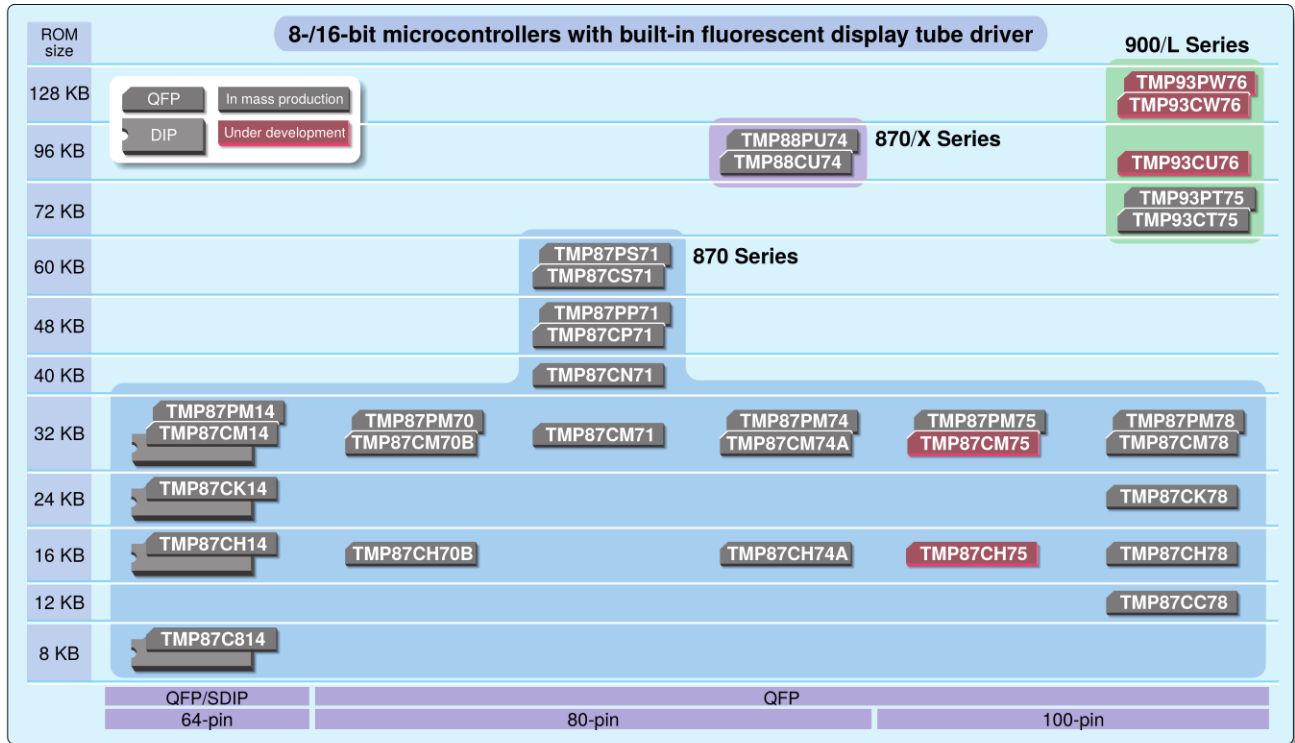

### ● 16-bit microcontroller (900/L Series)

Series Name	Product No.	ROM (bytes)	RAM (bytes)	I/O	VFT Driver	Additional Functions	Version with Built-in OTP	Package
900/L	TMP93CT75F	72K	1.8K	85	14 seg. × 10 dig. (maximum breakdown voltage: 40 V)	<ul style="list-style-type: none"> <li>● Serial interface: 1 channel; I<sup>2</sup>C bus: 2 channels</li> <li>● 8-bit AD converter: 10 channels</li> <li>● 14-bit PWM timer: 3 channels</li> <li>● VCR servo controller</li> </ul>	●	QFP100 (14 × 20 mm)
	*TMP93CU76F	96K	2.5K	85		<ul style="list-style-type: none"> <li>● Serial interface: 1 channel; I<sup>2</sup>C bus: 2 channels (including FIFO)</li> <li>● 8-bit AD converter: 10 channels</li> <li>● 14-bit PWM timer: 3 channels</li> <li>● VCR servo controller</li> </ul>	●	
	*TMP93CW76F	128K						

† For details of the products listed above, please refer to the **900 Family** Selection Guide on page 29.

\* Under development

### ● 8-bit microcontrollers (870 Series, 870/X Series)

Series Name	Product No.	ROM (bytes)	RAM (bytes)	I/O	VFT Driver	Additional Functions	Version with Built-in OTP	Packages
870	TMP87C814N/F	8K	512	55	Maximum breakdown voltage: 40 V on each of 24 pins	<ul style="list-style-type: none"> <li>● 8-bit AD converter: 8 channels</li> <li>● 8-bit SIO: 1 channel</li> <li>● 16-bit timer/counter: 2 channels</li> <li>● 8-bit timer/counter: 2 channels</li> </ul>	●	SDIP64/ QFP64
	*TMP87CH14N/F	16K						
	TMP87CK14N/F	24K						
	TMP87CM14N/F	32K	1K	73	Maximum breakdown voltage: 40 V on each of 32 pins	<ul style="list-style-type: none"> <li>● AD converter input: 6 channels</li> <li>● 8-bit SIO: 1 channel</li> <li>● High-speed serial output</li> </ul>	●	QFP80
	TMP87CH70BF	16K						
	TMP87CM70BF	32K						
	TMP87CM71F	32K	1.5K	73	16 seg. × 16 dig.	<ul style="list-style-type: none"> <li>● AD converter input: 6 channels</li> <li>● 8-bit SIO: 1 channel</li> <li>● High-speed serial output</li> </ul>	●	QFP80
	TMP87CN71F	40K						
	TMP87CP71F	48K						
	TMP87CS71F	60K	2K	71	Maximum breakdown voltage: 40 V on each of 37 pins Programmable grid scan output	<ul style="list-style-type: none"> <li>● 8-bit AD converter: 12 channels</li> <li>● 8-bit SIO: 2 channels</li> <li>● 16-bit timer/counter: 2 channels, 8-bit timer/counter: 2 channels</li> </ul>	●	QFP100
	TMP87CH74AF	16K	512					
	TMP87CM74AF	32K	1K					
	*TMP87CH75F	16K	512	89	Maximum breakdown voltage: 40 V on each of 51 pins Programmable grid scan output	<ul style="list-style-type: none"> <li>● 8-bit AD converter: 16 channels</li> <li>● 8-bit SIO: 2 channels</li> <li>● 16-bit timer/counter: 2 channels, 8-bit timer/counter: 2 channels</li> </ul>	●	QFP100
	*TMP87CM75F	32K	1K					
TMP87CC78F	12K							
TMP87CH78F	16K	512	89	Maximum breakdown voltage: 40 V on each of 50 pins	<ul style="list-style-type: none"> <li>● 8-bit AD converter: 8 channels</li> <li>● UART: 2 channels</li> <li>● 16-bit timer/counter: 1 channel</li> <li>● 8-bit timer/counter: 4 channels</li> </ul>	●	QFP100	
TMP87CK78F	24K							
TMP87CM78F	32K	1K						
870/X	TMP88CU74F	96K	2K	71	Maximum breakdown voltage: 40 V on each of 37 pins Programmable grid scan output	<ul style="list-style-type: none"> <li>● 8-bit SIO: 1 channel</li> <li>● 16-bit timer/counter: 2 channels</li> </ul>	●	QFP80

† For details of the products listed above, please refer to the **870 Series** Selection Guide on pages 36 and 37, or the **870/X Series** Selection Guide on page 39.

\* Under development

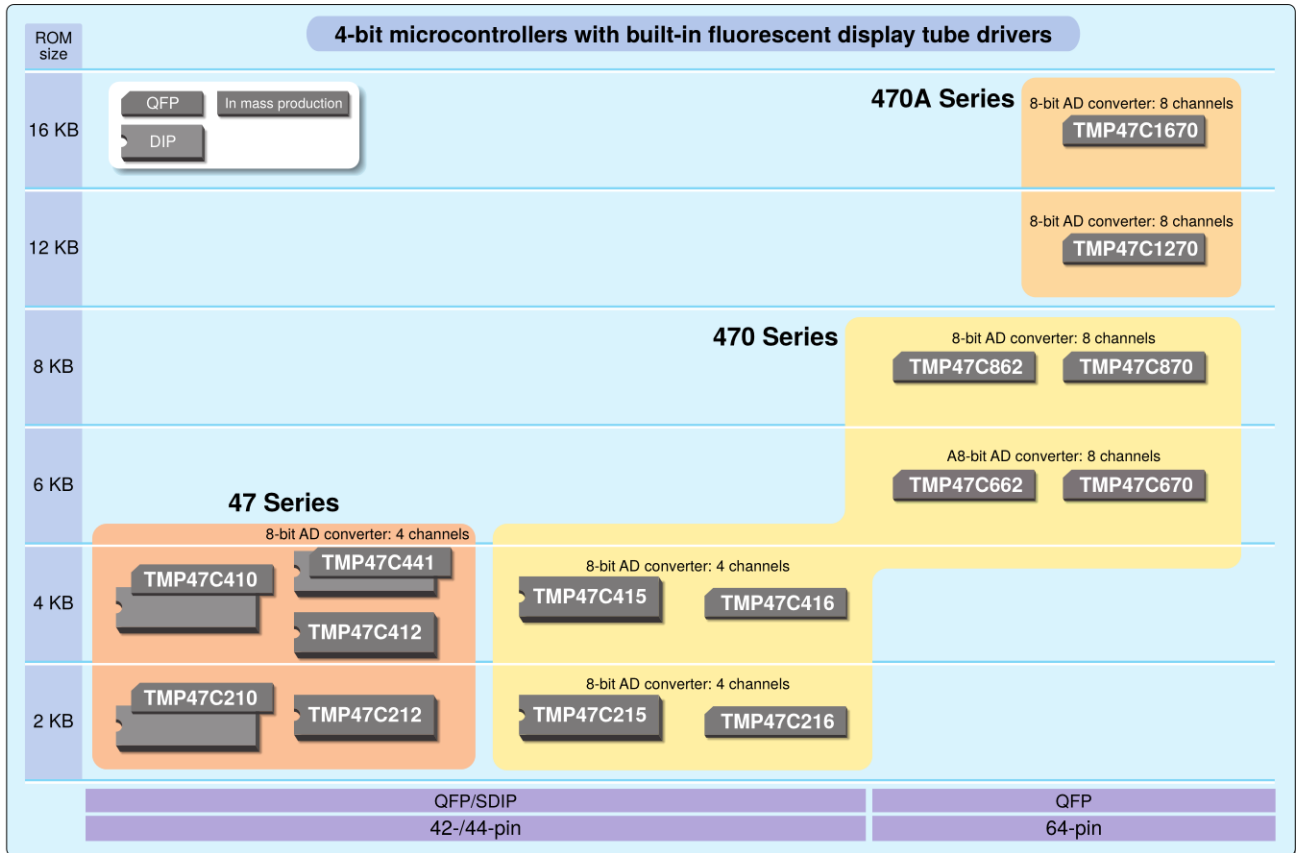

### ● 4-bit microcontroller (47 Family)

Series Name	Product No.	ROM (bytes)	RAM (nibbles)	I/O	VFT Driver	Additional Functions	Version with Built-in OTP	Packages
47	TMP47C210AN/AF	2K	128	36	Maximum breakdown voltage: 42 V on each of 20 pins	<ul style="list-style-type: none"> <li>● 4-bit SIO: 1 channel</li> <li>● 12-bit timer/counter: 2 channels</li> </ul>	●	SDIP42/QFP44
	TMP47C410AN/AF	4K	256	35			–	SDIP42
	TMP47C212AN	2K	128	34	Maximum breakdown voltage: 42 V on each of 16 pins	<ul style="list-style-type: none"> <li>● 8-bit AD converter: 4 channels</li> <li>● 4-bit SIO: 1 channel</li> </ul>	●	SDIP42/QFP44
	TMP47C412AN	4K	256					
	TMP47C441AN/AF	4K	4K					
470	TMP47C215N	2K	128	36	High breakdown voltage output: 23 pins	<ul style="list-style-type: none"> <li>● 8-bit AD converter: 4 channels</li> <li>● 8-bit SIO: 1 channel</li> </ul>	●	SDIP42
	TMP47C415N	4K	256	38	High breakdown voltage output: 24 pins		●	QFP44
	TMP47C216F	2K	128	55	Maximum breakdown voltage: 42 V on each of 27 pins	<ul style="list-style-type: none"> <li>● 8-bit AD converter: 8 channels</li> <li>● 8-bit SIO: 1 channel</li> <li>● Remote control signal preprocessing capability</li> <li>● Pulse output</li> </ul>	●	SDIP64
	TMP47C416F	4K	256					
	TMP47C662AN	6K	384	53	Maximum breakdown voltage: 42 V on each of 28 pins	<ul style="list-style-type: none"> <li>● 8-bit AD converter: 8 channels</li> <li>● 8-bit SIO: 1 channel</li> <li>● Remote control signal preprocessing capability</li> <li>● Pulse output</li> </ul>	●	
	TMP47C862AN	8K	512					
	TMP47C670N	6K	384	768	12 seg. × 16 dig. to 16 seg. × 12 dig.		●	
TMP47C870N	8K	512						
470A	TMP47C1270AN	12K	768				●	
	TMP47C1670AN	16K						

†For details of the products listed above, please refer to the **47 Family** Selection Guide on pages 45 and 46.

# CISC APPLICATIONS



## Single-chip TV microcontrollers

These single-chip 8-bit microcontrollers for TV incorporate an on-screen display circuit, which can be used to display characters and symbols on screen, and a peripheral circuit for controlling station selection. The devices are optimized for digital tuning system applications. The product line-up features devices with ROM sizes ranging from 12 Kbytes to 60 Kbytes (in the case of the **870 Series**).

### Main Functions

- Advanced 8-bit core (870 Series)
- High ROM and RAM capacity
- High-speed operation, low power dissipation
- Serial interface: I<sup>2</sup>C bus

ROM size	8-bit TV microcontrollers with a built-in OSD circuit					OSD (24-digit × 12-line)	
60 KB	 QFP    In mass production DIP    Under development	A8700PS	A8700PS			8-bit AD converter: 6 channels I <sup>2</sup> C bus interface: 2 channels 14-bit PWM: 1 channel 7-bit PWM: 9 channels	
		A8700CS				87PS38 87CS38 87PS39 87CS39	
48 KB		A8700CP				OSD (24-digit × 12-line) 8-bit AD converter input: 4 channels I <sup>2</sup> C bus interface: 1 channel 14-bit PWM: 1 channel 7-bit PWM: 9 channels	
32 KB		87PM34A 87CM34B	A8700CM	A8701CM	87PM36 87CM36	87CP38 87CP39 87CM38 87CM39	
24 KB	OSD (24-digit × 4-line) 8-bit AD converter input: 4 channels 14-bit PWM: 1 channel 7-bit PWM: 9 channels	87CK34B	A8700CK	A8701CK	87CK36	87CK38	OSD (24-digit × 12-line) 8-bit AD converter: 8 channels I <sup>2</sup> C bus interface: 2 channels 14-bit PWM: 1 channel 7-bit PWM: 9 channels
16 KB		87CH31 87CH34B	A8700CH	A8701CH	87CH36	87CH38	
12 KB		87CC31					OSD for U.S. broadcast sub-titles (32-digit × 8-line) 8-bit AD converter input: 4 channels I <sup>2</sup> C bus interface: 2 channels 14-bit PWM: 1 channel 7-bit PWM: 9 channels
							OSD for U.S. broadcast sub-titles (32-digit × 8-line) 8-bit AD converter: 6 channels I <sup>2</sup> C bus interface: 2 channels
							OSD (24-digit × 8-line) 8-bit AD converter: 6 channels I <sup>2</sup> C bus interface: 2 channels 14-bit PWM: 1 channel 7-bit PWM: 9 channels
	SDIP/QFP (14 × 14mm)					SDIP	
	42/44-pin					64-pin	

### ● 8-bit microcontrollers (870 Series)

Series Name	Product No.	ROM (bytes)	RAM (bytes)	I/O	On-Screen Display	Additional Functions	Version with Built-in OTP
870	TMPA8700CHN/F	16K	1K	33	For U.S. broadcast sub-titles 32-digit × 8-line display	● 8-bit AD converter: 6 channels ● I <sup>2</sup> C bus interface: 2 channels ● 14-bit PWM: 1 channel ● 7-bit PWM: 9 channels	TMPA8700PSN/F
	TMPA8700CKN/F	24K					
	TMPA8700CMN/F	32K					
	TMPA8700CPN/F	48K					
	TMPA8700CSN/F	60K	2K				
	TMPA8701CHN/F	16K	768	33	For U.S. broadcast sub-titles 32-digit × 8-line display	● 8-bit AD converter: 6 channels ● I <sup>2</sup> C bus interface: 2 channels	TMPA8700PSN/F
	TMPA8701CKN/F	24K					
	TMPA8701CMN/F	32K					
	TMP87CC31N	12K	256	34	24-digit × 4-line display	● 6-bit AD converter input: 4 channels ● 14-bit PWM: 1 channel 7-bit PWM: 9 channels	TMP87PM36N
	TMP87CH31N	16K					
	TMP87CH34BN	16K					
	TMP87CK34BN	24K	1K	33	For U.S. broadcast sub-titles 32-digit × 8-line display	● 6-bit AD converter input: 4 channels ● I <sup>2</sup> C bus interface: 2 channels ● 14-bit PWM: 1 channel 7-bit PWM: 9 channels	TMP87PM34AN
	TMP87CM34BN	32K					
	TMP87CH36N	16K					
	TMP87CK36N	24K					
	TMP87CM36N	32K	512	34	24-digit × 12-line display	● 6-bit AD converter input: 4 channels ● I <sup>2</sup> C bus interface: 1 channel ● 14-bit PWM: 1 channel 7-bit PWM: 9 channels	TMP87PM36N
	TMP87CH38N/F	16K					
	TMP87CK38N/F	24K					
	TMP87CM38N/F*	32K					
TMP87CM38N/F*	32K	1K	33	24-digit × 12-line display	● 8-bit AD converter: 6 channels ● I <sup>2</sup> C bus interface: 2 channels ● 14-bit PWM: 1 channel 7-bit PWM: 9 channels	TMP87PS38N/F	
TMP87CP38N/F*	48K						
TMP87CS38N/F*	60K						
TMP87CM39N	32K	1K	55	24-digit × 12-line display	● 8-bit AD converter: 8 channels ● I <sup>2</sup> C bus interface: 2 channels ● 14-bit PWM: 1 channel 7-bit PWM: 9 channels	TMP87PS39N	
TMP87CP39N	48K						
TMP87CS39N	60K						

\* For details of the products listed above, please refer to the **870 Series** Selection Guide on pages 36 and 37.

\* Under development

# Microcontrollers with built-in AD converter



ROM size		8-bit microcontrollers with built-in AD converter					
	<b>TMPxxxxxx</b> QFP In mass production DIP						
60 KB					87PS64 87CS64		
48 KB					87CP64		
32 KB		8-bit AD converter: 6 channels I <sup>2</sup> C bus interface 87PM43 87CM43	8-bit AD converter: 8 channels 87PM40A 87CM40A	10-bit AD converter: 16 channels 87PM41 87CM41	8-bit AD converter: 8 channels 87PM53 87CM53 87CM64 8-bit AD converter: 16 channels		
24 KB		87CK43 8-bit AD converter: 6 channels		87CK40 87CK41			
16 KB			87PH46 87CH46 87PH47 87CH47 87PH47L 87CH47L (1.8-V, 4.2-MHz version)	87PH40A 87CH40 87CH41			
12 KB				87CC40 87CC41			
8 KB		8-bit AD converter: 4 channels 8-bit DA converter: 8 channels I <sup>2</sup> C bus interface 87P808 87C808 87P808L 87C808L 87P844 87C844 87C846 87C847		87C840 87C841			
4 KB		87C408 87C408L 87C444 87C446 87C447 (1.8-V, 4.2-MHz version)					
		SOP/SDIP	SDIP	μQFP (10 × 10mm)	QFP/SDIP	μQFP/QFP SDIP	QFP
		28-pin	42-pin	44-pin	64-pin	80-pin	100-pin

ROM size		4-bit microcontrollers with built-in AD converter				
	<b>TMPxxxxxx</b> Built-in OTP Mask ROM					
16 KB					8-bit SIO 47P1660V 47C1660	
12 KB					47C1260	
8 KB			8-bit SIO 47P840V 47C840	8-bit SIO VFT 47P862 47C862A	8-bit SIO LCD 47P860 47C860 47C847	
6 KB				47C640	47C662A 47C660 47C647	
4 KB		8-bit SIO 47P443V 47C443	8-bit SIO LCD 47P422V 47C422	8-bit SIO VFT 47P441A 47C441	4-bit SIO 47P440V 47C440B	
				4-bit SIO LCD 47P446V 47C446A		
2 KB		8-bit SIO 47P241V 47C241	47C243 47C222			
		28-pin	42-pin (QFP-44)	64-pin	80-pin	

# 900 Family

## 16-bit and 32-bit microcontrollers developed for C language code efficiency

The 900 Family is made up of highly functional microcontrollers combining the best of Toshiba technologies.

The microcontrollers in this family are available as the processor core for a wide variety of applications, including office equipment, such as printers and fax machines, complex electronic household appliances, such as VCRs and video cameras, cellular 'phones and other information-based equipment.

### Core expansion keeping pace with applications

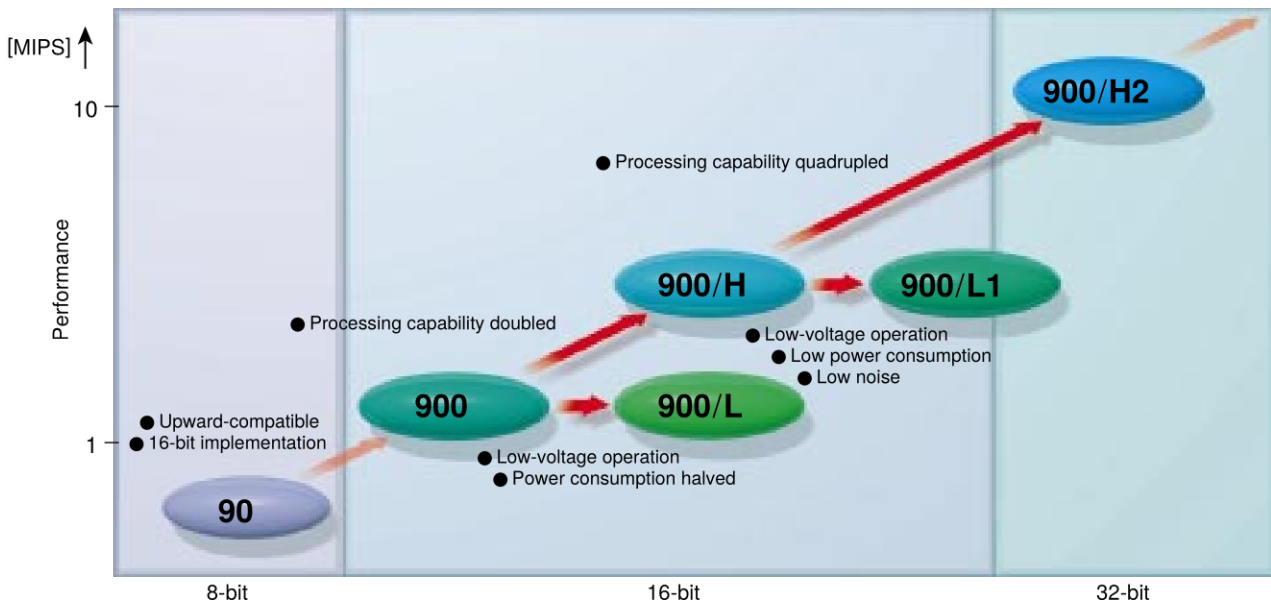

### Processor core features

	900/H2 Series	900/H & 900/L1 Series	900 & 900/L Series
Maximum operating frequency (@input frequency)	20 MHz (@10 MHz)	12.5 MHz (@25 MHz)	10 MHz (@20 MHz)
Minimum instruction execution time	50 ns	160 ns	200 ns
Address space	16 Mbytes of linear address space (for program and data)		
Data transfer rate (micro DMA)	0.25 $\mu$ s	0.64 $\mu$ s	1.6 $\mu$ s
32-bit data-processing instructions	Transfer, arithmetic/logic operations and shift instructions		
Bit-processing instructions	Transfer, logic operations, test, set, reset and search		
Multiplication instruction execution time (16-bit operands, 32-bit result)	600 ns	960 ns	2.6 $\mu$ s
Dynamic bus sizing	8-/16-/32-bit	8-/16-bit	

### Register model

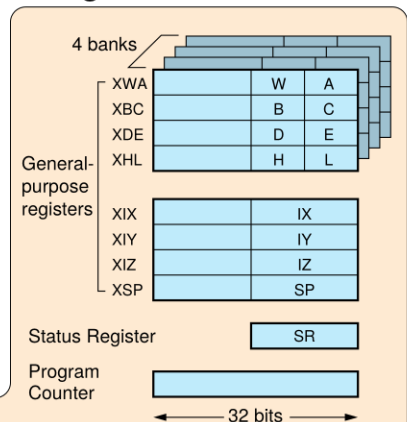

### Main applications

**Office equipment**

Printers

Fax machines

**Home electronics**

DVD players

Digital video cameras

**Portable devices**

PICs

Cellular 'phones  
e.g. PHS

- **32-bit wide general-purpose registers**  
Can be used for address calculations.  
Code size reduction is possible.
- **Numerous general-purpose registers**  
Flexible code generation by compiler.  
Code size reduction is possible.
- **Register bank method**  
Ideal for real-time processing.

900 Family

# 900/L Series

*Low power consumption design ideal for high-performance portable equipment*



- Low-voltage operation
  - Operating supply voltage: 4.5 V to 5.5 V @20 MHz
  - 2.7 V to 5.5 V @12.5 MHz
- Designed for low power consumption

## Comparison of power consumption levels

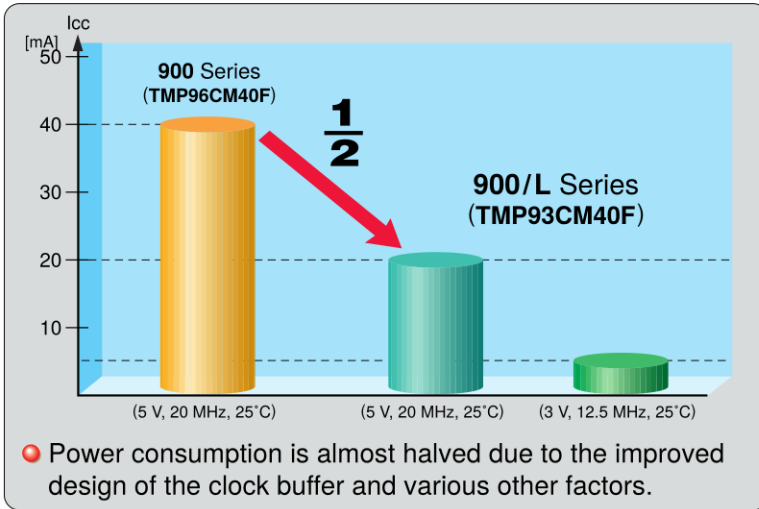

## Four standby modes

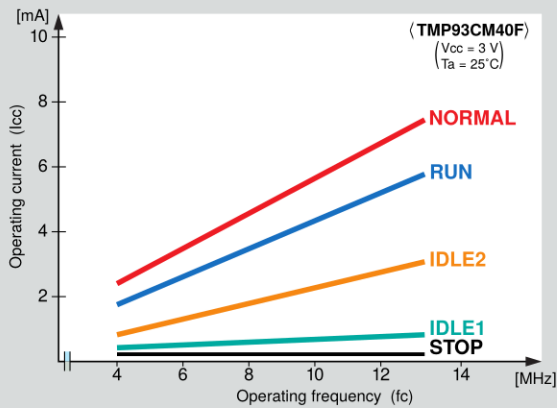

Operation Mode	CPU	AD	Peripheral I/O (other than AD)	Oscillator Circuit
NORMAL	●	●	●	●
RUN	—	●	●	●
IDLE2	—	—	●	●
IDLE1	—	—	—	●
STOP	—	—	—	—

● : Operating — : Operation halted

## Clock gear function

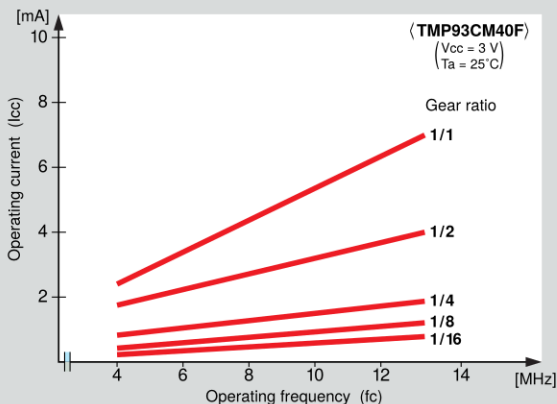

## Dual clock function

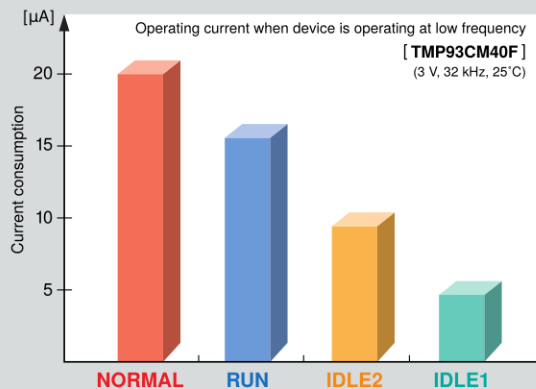

# 900 Family 900/H Series

High-performance devices ideally suited  
to high-end office equipment



- Processing capability doubled (relative to the 900 Series)
- Applications
  - Serial printers
  - Electronic musical instruments
- CD-ROM drives
- HDDs

## Block diagram of serial printer

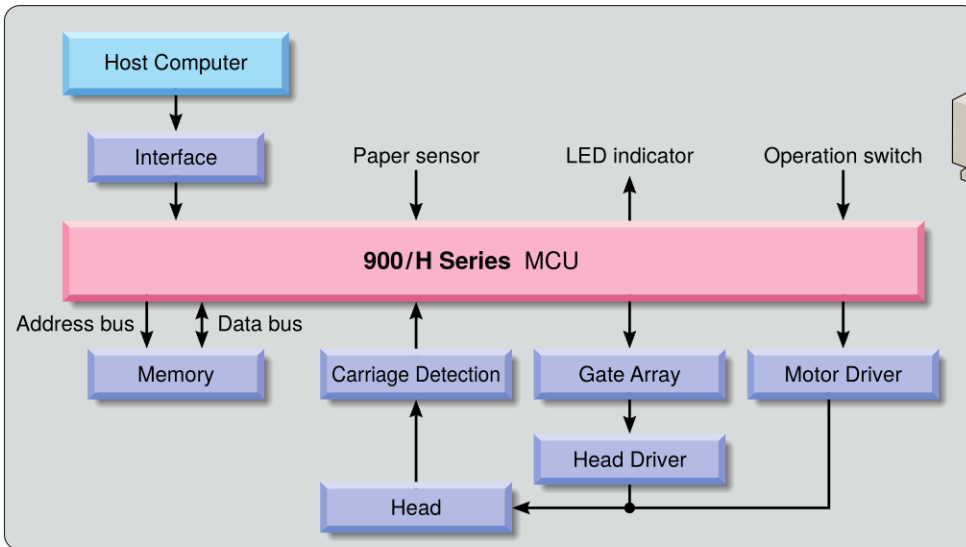

## Full DRAM control functions

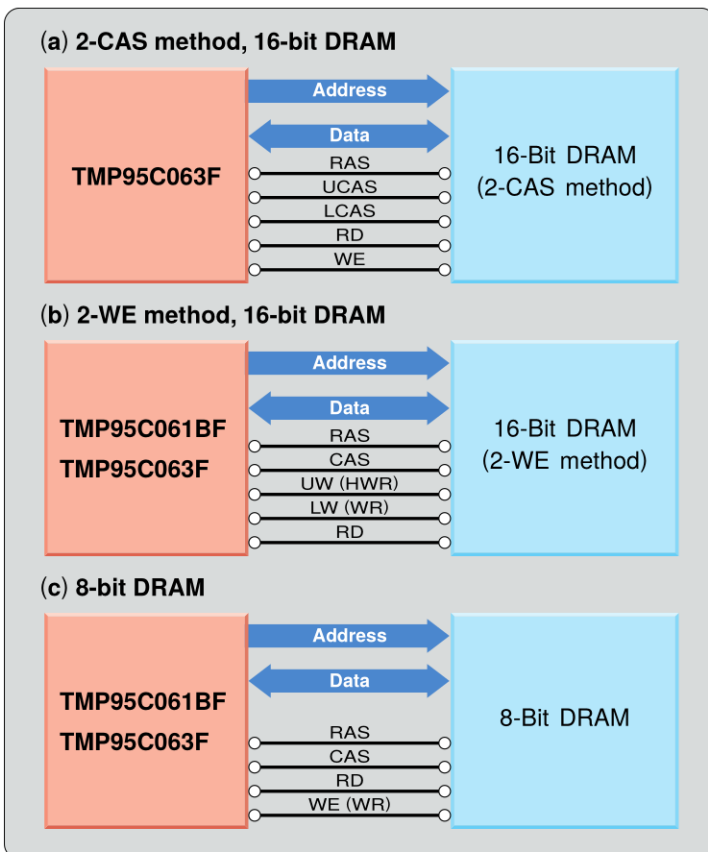

- Devices can be connected directly to various types of DRAM.
- Since memory is refreshed asynchronously from CPU operation, access to other resources is not degraded.

CD-ROM drives



Electronic musical instruments

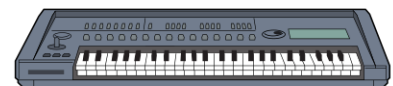

900 Family

# 900/L1 Series

*Next-generation 16-bit microprocessors offering both high performance and low-power operation*



- Low-voltage operation: 1.8 V to 5.5 V
- Low power consumption: 3.0 mA (when operating at 3 V and 16 MHz)
- Low noise (EMC register)
  - EMI: reduced by 30%
  - EMS: noise filter, protection register

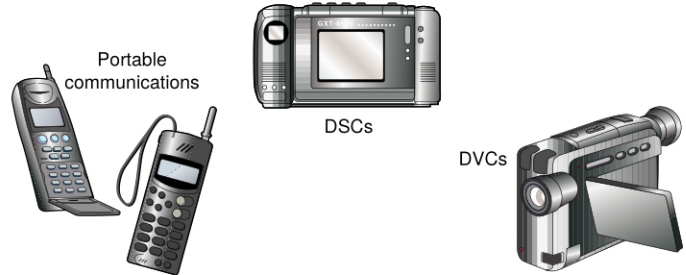

## Low power consumption design

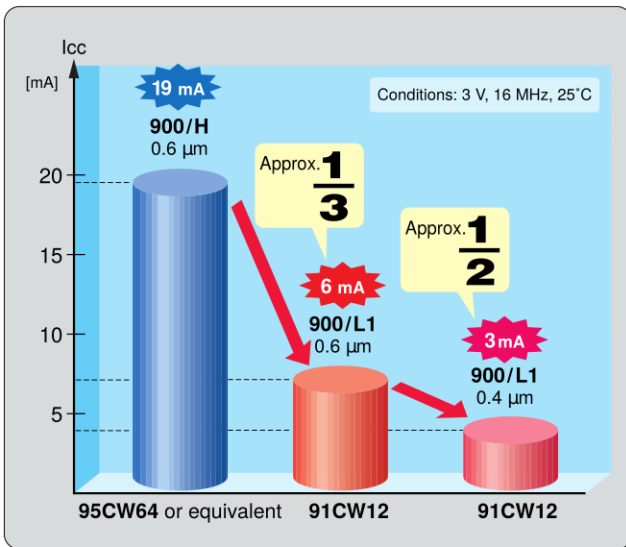

## Typical techniques for low power consumption design

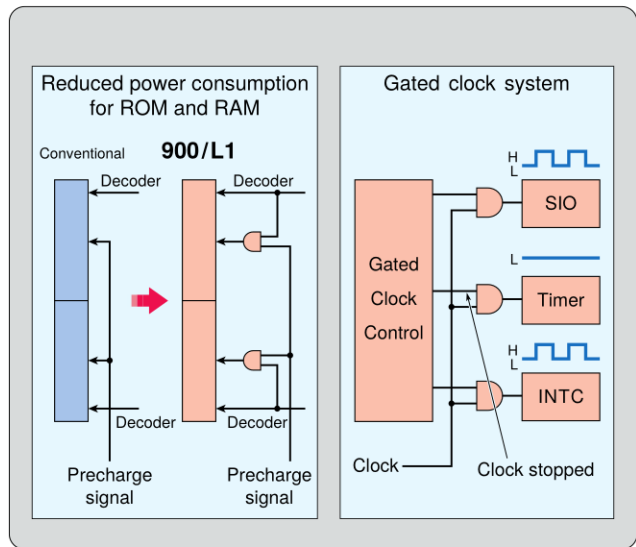

## Core expansion plan

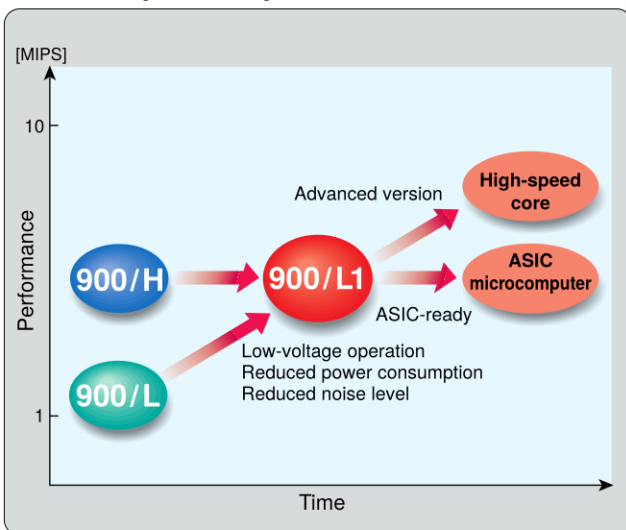

## Comparison of core performance (with 900/L)

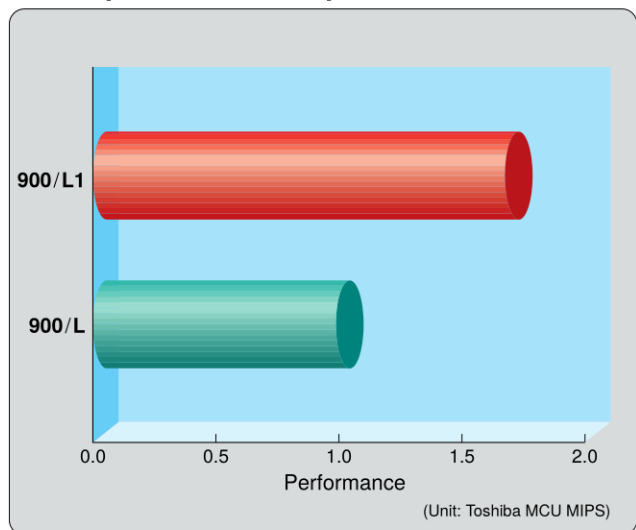



# 900 Family

# 900/H2 Series

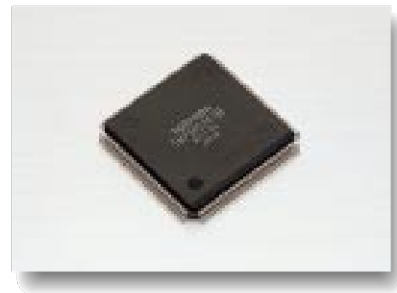

**High-performance microcontrollers  
incorporating a 32-bit CPU core**

- Approximately 4 times the processing performance of conventional products (e. g. the 900/H Series)

## Comparison of instruction execution times

Instruction	Operand Size		
	8-bit	16-bit	32-bit
● Data transfer 1 LD reg, reg	50 (900/H2 Series) vs 160 (Conventional products)	50 (900/H2 Series) vs 160 (Conventional products)	50 (900/H2 Series) vs 160 (Conventional products)
● Data transfer 2 LD reg, mem	100 vs 320	100 vs 320	100 vs 480
● Arithmetic operation ADD reg, imm	50 vs 240	50 vs 320	50 vs 480
● Bit manipulation SET imm, reg	50 vs 240	50 vs 240	
● Branching JR disp8	100 vs 400		

Unit: ns

- Enhanced high-speed data transfer function (micro DMA)

900/H2 Series microcontrollers come with a high-speed data transfer function, equivalent to that of a DMAC (direct memory access controller), as standard.

## Function and performance comparison

Parameter	900 Series 900/L Series	900/H Series 900/L1 Series	900/H2 Series
Number of channels	4 channels	4 channels	8 channels
Minimum transfer time	1600 ns (2 bytes)	640 ns (2 bytes)	250 ns (4 bytes)
Initiated by	Interrupt	Interrupt and software trigger	Interrupt and software trigger
Continuous Transfer Mode	NA	NA	Available

- Diverse memory types fully utilized

The 900/H2 Series architecture allows various kinds of external memory chip to be connected directly to the CPU core without the need for an external circuit. Furthermore, the internal memory is connected to the CPU core via a 32-bit data bus and the internal RAM can be accessed in a single clock cycle.

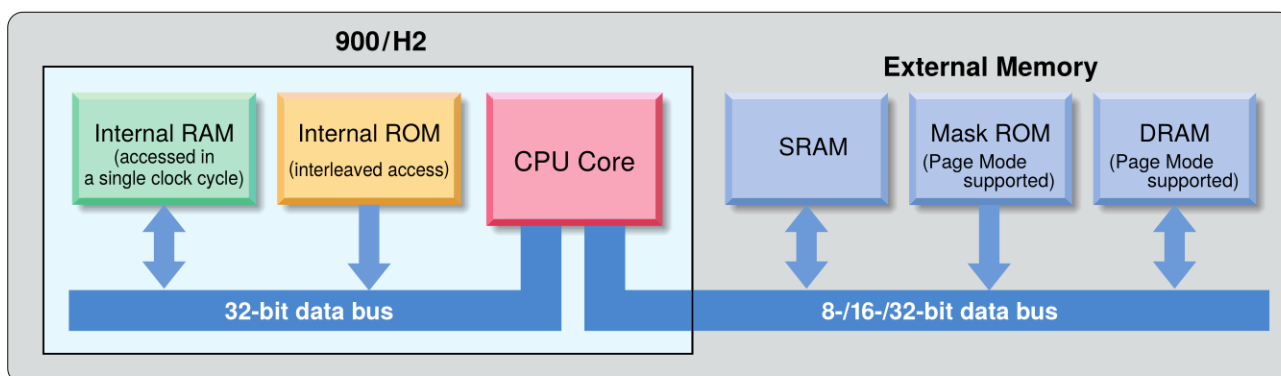

## 900 Family Selection Guide

ROM (bytes)	RAM (bytes)	Product No.	Minimum Instruction Execution Time (ns)		CAN	SEI	SIO/UART	Synchronous SIO	I <sup>2</sup> C Bus/SIO	DRAM Controller	AD Converter 10-bit channels 8-bit channels 6-bit channels	8-bit DA Converter	LCD Driver	VFT Driver	Timer/Counter 8-bit channels 16-bit channels	Clock timer	Timebase Counter	Pattern Generator	Stepping Motor Controller	8-bit PWM Timer	14-bit PWM Timer	CS Wait Controller	Watchdog Timer	Dual Clock	Clock Gear	I/O Port	Operating Temperature (°C)	Version with Built-in OTP	Packages (mm)
			5 V ± 10%	3 V ± 10%																									

### 900 Series

NA	NA	TMP96C041BF	Note 2 200	-	-	-	2	-	-	-	-	-	-	4	-	-	2	2	-	2	-	2	-	3	-	●	-	-	47	-40 to 85	-	QFP80 (14 × 20)	
		TMP96C031ZF					-	-	2	-	-	1	4	-	-	-	-	4	1	-	-	2	-	-	4	-	●	-	-		37		-
	1K	TMP96C141BF			-	-	2	-	-	-	-	-	-	4	-	-	2	2	-	-	2	-	2	-	3	-	●	-	-	47		-	QFP80 (14 × 20)
32K		TMP96CM40F			-	-	2	-	-	-	-	-	-	4	-	-	2	2	-	-	2	-	2	-	3	-	●	-	-	65		TMP96PM40F	

### 900/L Series

NA	2K	TMP93CS41F/DF	320	-	-	-	2	-	-	-	-	-	8	-	-	2	2	-	2	-	2	-	3	-	●	●	●	61	-40 to 85	-	QFP100 (14 × 14)		
		TMP93CS45F					-	-	2	-	1	-	-	-	8	-	-	4	2	-	-	-	-	-	-	-	●	●		●	44		-
	4K	TMP93CW41DF			-	-	2	-	-	-	-	-	8	-	-	2	2	-	-	2	-	2	-	3	-	●	●	●	61		-	QFP100 (14 × 14)	
	8K	TMP93C071F			-	-	1	2	1	-	-	16	-	-	-	1	5	●	●	-	-	3	3	●	●	●	-	69		-20 to 70	-	QFP120 (28 × 28)	
8K	1K	TMP93C852F			-	-	-	6	-	-	-	-	-	-	-	-	-	-	4	-	3	-	3	-	●	-	●	88		-	QFP160 (28 × 28)		
32K	2K	TMP93CM40F			400	-	-	2	-	-	-	-	8	-	-	2	2	-	-	2	-	2	-	3	-	●	●	●	79		TMP93PS40F/DF	QFP100 (14 × 14)	
		TMP93CS20F	200		-	-	2	-	1	-	-	-	8	-	●	-	4	4	●	-	-	-	-	-	●	●	●	88		TMP93PW20AF	QFP144 (16 × 16)		
		TMP93CS32F				320	-	-	2	-	-	-	-	6	-	-	4	2	-	-	-	-	-	-	-	●	-	●	49		TMP93PW32F	QFP64 (14 × 14)	
		TMP93CS40F/DF			-	-	2	-	-	-	-	-	8	-	-	2	2	-	-	2	-	2	-	3	-	●	●	●	79		TMP93PS40F/DF	QFP100 (14 × 14)	
		TMP93CS42AF			-	-	2	-	-	-	-	-	5	-	-	2	2	-	-	-	2	-	3	-	●	-	●	80		TMP93PS42AF	QFP64 (14 × 14)		
		TMP93CS44F			320	-	-	2	-	1	-	-	8	-	-	4	2	-	-	-	-	-	-	-	●	●	●	62		TMP93PS44F	QFP80 (12 × 12)		
72K	1.8K	TMP93CT75F	250		-	-	-	-	1	-	-	10	-	-	●	1	5	●	●	-	-	3	-	●	●	●	-	85		-10 to 70	TMP93PT75F	QFP100 (14 × 20)	
96K	3K	TMP93CU44DF	200	320	-	-	2	-	1	-	-	-	8	-	-	4	2	-	-	-	-	-	-	-	●	●	●	62		-40 to 85	*TMP93PW44DF TMP93PW44ADF	QFP80 (14 × 20)	
	2.5K	*TMP93CW76F	250		-	-	-	-	1	1	-	-	10	-	-	●	1	5	●	●	-	-	3	-	●	●	●	-	85		-20 to 70	*TMP93PW76F	QFP100 (14 × 20)
		TMP93CW40DF	200		-	-	2	-	-	-	-	-	8	-	-	2	2	-	-	2	-	2	-	3	-	●	●	●	79		TMP93PW40DF	QFP100 (14 × 14)	
	4K	TMP93CW46AF				320	-	-	5	-	-	-	-	8	-	-	2	2	-	-	-	2	-	3	-	●	●	●	79		-40 to 85	TMP93PW46AF	QFP100 (14 × 14)
		TMP93CW44DF			-	-	2	-	1	-	-	-	8	-	-	4	2	-	-	-	-	-	-	-	●	●	●	62		*TMP93PW44DF TMP93PW44ADF	QFP80 (14 × 20)		

### 900/H Series

NA	NA	TMP95C001F	160	320	-	-	-	-	-	-	-	-	-	-	-	-	-	-	-	-	-	-	-	-	-	-	-	-	4	-	-	-	0	-20 to 70	-	QFP64 (14 × 14)
		TMP95C061BF					-	-	2	-	-	1	-	-	4	-	-	4	2	-	-	2	-	-	-	4	-	●	-	-	56		-		QFP100 (14 × 14)	
		TMP95C063F			-	-	2	-	-	2	-	-	8	2	-	8	2	-	-	2	-	-	-	4	-	●	-	-	91		-	QFP144 (20 × 20)				
		TMP95C265F			400	-	-	3	-	-	-	-	8	2	-	8	2	-	-	-	-	-	-	4	-	●	-	-	55		-	-				
	2K	*TMP95CS54F	167		-	1	1	2	-	-	-	-	8	-	-	8	2	-	-	-	-	-	-	-	●	-	-	81		-40 to 85	TMP95PS54F	QFP100 (14 × 14)				
		TMP95CS64F			400	-	-	3	-	-	-	-	8	2	-	8	2	-	-	-	-	-	-	4	-	●	-	-	81		-40 to 85	TMP95PW64F	QFP100 (14 × 14)			
128K	4K	TMP95CW64F	160		-	-	3	-	-	-	-	-	8	2	-	8	2	-	-	-	-	-	-	4	-	●	-	-	81		-20 to 70	TMP95PW64F	QFP100 (14 × 14)			
256K	8K	*TMP95FY64F			-	-	3	-	-	-	-	-	8	2	-	8	2	-	-	-	-	-	-	4	-	●	-	-	81		-	-				

### 900/L1 Series

96K	3K	TMP91CU10F	-	296	-	-	3	-	-	-	-	-	8	-	-	8	2	-	-	-	-	-	-	3	-	●	●	●	80	-40 to 85	TMP91PW10F	QFP100 (14 × 14)
		TMP91CW11F		320	-	-	3	2	1	-	-	-	8	-	-	2	2	●	-	-	-	2	-	3	-	●	●	●	79			
	4K	TMP91CW12F		250	-	-	2	-	1	-	-	-	8	-	-	8	2	●	-	-	-	-	4	-	●	●	●	81		TMP91PW12F		
		*TMP91CW12AF		150	-	-	2	-	1	-	-	-	8	-	-	8	2	●	-	-	-	-	4	-	●	●	●	81		-		

### 900/H2 Series

NA	2K	TMP94C241BF	50	-	-	-	2	-	-	2	-	-	8	2	-	4	4	-	-	-	-	-	-	6	6	●	-	-	64	-20 to 70	-	QFP160 (28 × 28)
----	----	-------------	----	---	---	---	---	---	---	---	---	---	---	---	---	---	---	---	---	---	---	---	---	---	---	---	---	---	----	-----------	---	------------------

\* Under development

Note 1: The suffix F in a product number denotes a quad flat package (QFP).

Note 2: Guaranteed minimum instruction execution time is 200 ns when device is operating at temperatures of -20° to 70°C, or 250 ns when device is operating at temperatures of -40° to 85°C.

# NEW PRODUCTS

900/L1 Series product with ultra-low power consumption and low noise

NEW

## TMP91CW12F/PW12F

### Low-voltage operation, low power consumption and low-noise technology combined into one device

The **TMP91CW12F/PW12F** are new products, capable of operating at voltages of as low as 2.7 V. They feature low power consumption (1/3 that of conventional Toshiba products) and low-noise operation. The ground pin is positioned so as to minimize noise and the devices include a PLL circuit, a noise filter and an EMC register. They also contain both a 16-bit and an 8-bit timer/counter, a serial interface, a 10-bit AD converter and a timer, making them ideal for battery-powered portable equipment such as PDAs, portable 'phones, digital cameras and other highly functional devices.



- Internal ROM
  - TMP91CW12F**: mask ROM, 128 Kbytes
  - TMP91PW12F**: EPROM, 128 Kbytes
- Internal RAM
  - TMP91CW12F**: 4 Kbytes
  - TMP91PW12F**: 4 Kbytes
- Timer
- Programmable Idle Mode
  - Clock to any peripheral can be stopped to achieve low-power operation.
- 16-bit timer/counter: 2 channels
- 8-bit timer/counter: 8 channels
- SIO/UART: 2 channels
- I<sup>2</sup>C bus/SIO: 1 channel
- 10-bit AD converter: 8 channels
- 100-pin miniflat package
  - (14 mm × 14 mm, 0.5-mm pitch, 1.4 mm thick)

Low-noise 900/L Series microcontrollers with I<sup>2</sup>C bus interface

NEW

## TMP93CU44DF/CW44DF/PW44DF\* \*Under development

### Multi-function, high-capacity, low-noise, low-voltage, low power dissipation 16-bit microcontrollers

The **TMP93CU44DF/CW44DF/PW44DF** are low-voltage, low power dissipation 16-bit microcontrollers based on the 900/H CPU and incorporating an I<sup>2</sup>C bus interface and a high-capacity memory. To reduce unnecessary radiated noise and to enable low-noise operation, a decoupling capacitor has been incorporated and the number of wiring harnesses has been optimized. With lower noise levels than existing products, these microcontrollers are suitable for a wider range of applications.

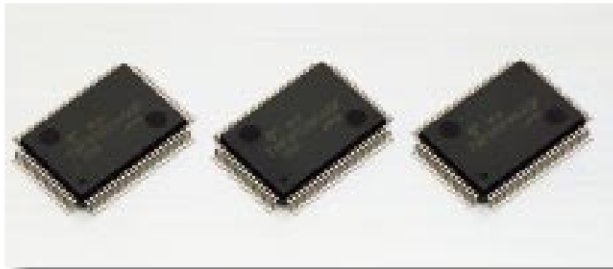

- Internal ROM
  - TMP93CU44DF**: mask ROM, 96 Kbytes
  - TMP93CW44DF**: mask ROM, 128 Kbytes
  - TMP93PW44DF**: OTP ROM, 128 Kbytes
- Internal RAM
  - TMP93CU44DF**: 3 Kbytes
  - TMP93CW44DF/PW44DF**: 4 Kbytes
- I<sup>2</sup>C bus/SIO: 1 channel
- SIO/UART: 2 channels
- 10-bit AD converter: 8 channels
- High-current output port: 8 pins
- Clock gear/Dual clock function
- Watchdog timer
- 16-bit timer/counter: 2 channels
- 8-bit timer/counter: 4 channels
- 80-pin miniflat package
  - (14 mm × 20 mm, 0.8-mm pitch, 2.7 mm thick)



Purchase of TOSHIBA I<sup>2</sup>C components conveys a license under the Philips I<sup>2</sup>C Patent Rights to use these components in an I<sup>2</sup>C system, provided that the system conforms to the I<sup>2</sup>C Standard Specification as defined by Philips.

# NEW PRODUCTS

900/H Series devices with built-in CAN controller

NEW

## TMP95CS54F/PS54F

### ■ 16-bit microcontrollers with built-in CAN controller

The **TMP95CS54F/PS54F** are 16-bit microcontrollers based on the **900/H** CPU. They are the first ever microcontrollers to incorporate the controller area network (CAN) communications protocol, the standard European protocol for vehicle LANs. The CAN has a maximum transfer rate of 1 Mbps.

The **TMP95CS54F/PS54F** also offer enhanced communications functions in the shape of a built-in serial expansion interface (SEI) for synchronous serial communications.

The **TMP95PS54F** version incorporates an OTP ROM.



- Internal ROM
  - TMP95CS54F**: mask ROM, 64 Kbytes
  - TMP95PS54F**: OTP ROM, 64 Kbytes
- Internal RAM: 2 Kbytes
- CAN controller: 1 channel
  - supports protocol 2.0B (standard and extended formats)
  - 16 mailboxes built in
- SEI: 1 channel
- 16-bit timer/counter: 2 channels
- 8-bit timer/counter: 8 channels
- SIO/UART: 2 channels
- 10-bit AD converter: 8 channels
- Operating voltage: 4.7 V to 5.3 V
- Operating temperature: -40°C to +85°C
- 100-pin miniflat package
  - (14 mm × 14 mm, 0.5-mm pitch, 1.4 mm thick)

900/H Series with flash E<sup>2</sup>PROM

NEW

## TMP95FY64F\*

\*Under development

### ■ 16-bit microcontrollers with built-in flash E<sup>2</sup>PROM

The **TMP95FY64F** is a 16-bit microcontroller based on the **900/H** CPU and incorporating a single 5-V flash memory.

This microcontroller incorporates all of the **900 Family's** standard functions. It is easy to reprogram the microcontroller without removing it from the PCB on which it is mounted.

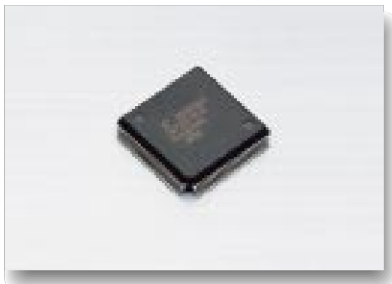

- Internal ROM: flash E<sup>2</sup>PROM, 256 Kbytes
- Internal RAM: 8 Kbytes
- CS/Wait controller: 4 blocks
- SIO/UART: 3 channels
- 10-bit AD converter: 8 channels
- 16-bit timer/counter: 2 channels
- 8-bit timer/counter: 8 channels
- 8-bit DA converter: 2 channels
- 100-pin miniflat package
  - (14 mm × 14 mm, 0.5-mm pitch, 2.7 mm thick)

# 8-Bit Microcontrollers

# 90 Series



## 8-bit microcontrollers suitable for control of office equipment systems and for consumer and industrial electronics

The 90 Series is made up of 8-bit microcontrollers suitable for use in various control applications.

- Microcontrollers with up to 60 Kbytes of ROM or no ROM are available.
- Microcontrollers with up to 4 Kbytes of RAM or no RAM are available.
- Minimum instruction execution time: 250 ns (at 16 MHz)
- Memory or I/O can be added externally: maximum of 8 Mbytes program/data area
- Enhanced instructions: multiplication and division instructions, 16-bit arithmetic instructions, bit-manipulation instructions
- Variety of interrupt types: vector to automatically handle internal and external interrupts, micro DMA function
- Standby modes

### Register configuration

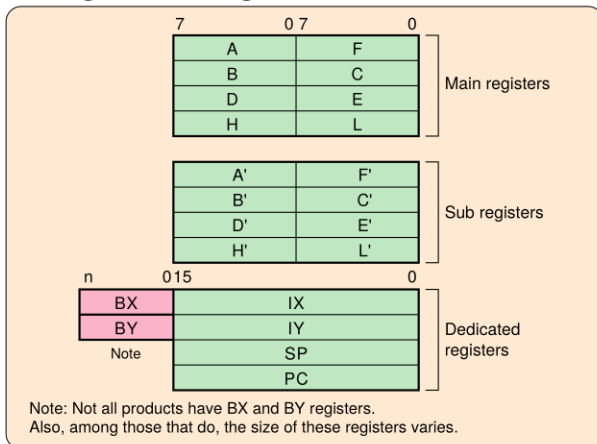

### High-speed operation with pipeline processing

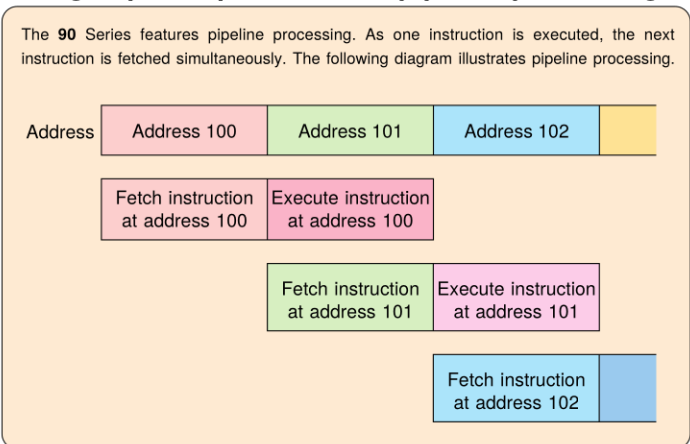

### Applications

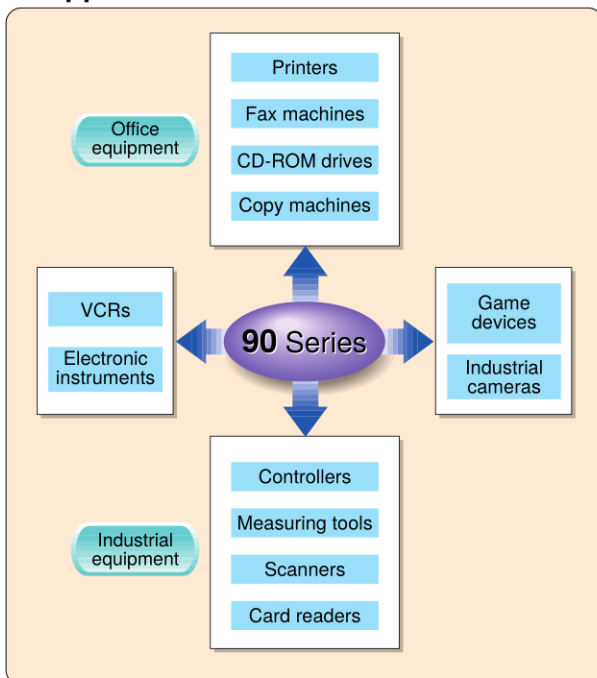

### Product line

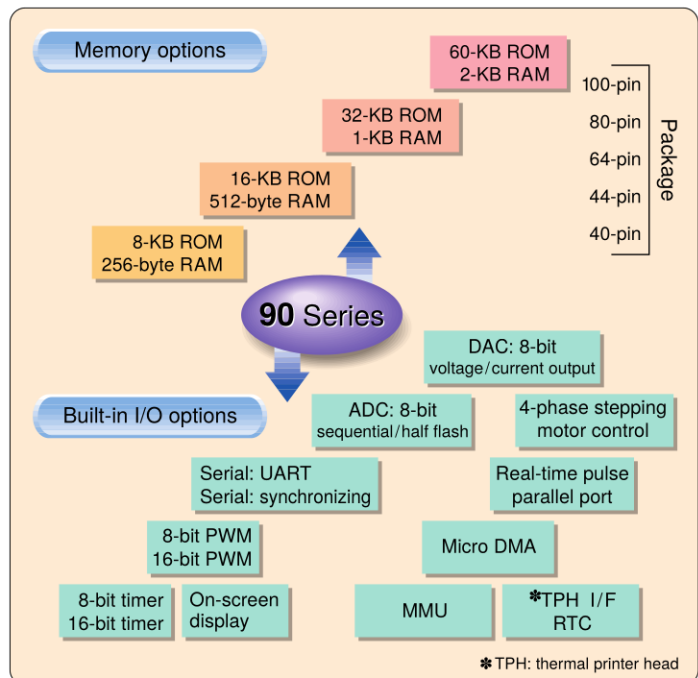

## ▶ 90 Series Selection Guide

ROM (bytes)	RAM (bytes)	Product No.	Minimum Instruction Execution Time (ns)	Serial Interface		I <sup>2</sup> C Bus Channels	Flash AD Converter Channels	8-Bit AD Converter Channels	Timer/ Counter	Watchdog Timer	High-speed PWM	Timebase Counter	Stepping Motor Controller	Timing Pulse Generator	VCR Servo Controller	OSD	MMU	DRAM Controller	High-Speed DMA	Slave Bus Interface	Real-Time Clock	Dual Clock	Power Supply Voltage (V)	Operating Temperature (°C)	Version with Built-in OTP	Packages			
				Synchronous	Asynchronous																								
OK	NA	TMP90C051F			2			4	●				●					●	●	●	●				–	QFP80			
		TMP90C041AN/AF			1	6		4	1	●			●													–	SDIP64, QFP64		
	128	TMP90C401N/F			1			4																		–	DIP40, SOP40		
	256	TMP90C801N/F	Note 320			1			4																		–	SDIP64, QFP64	
		TMP90C803AP/AM				1			4	●																	–	DIP40, SOP40	
	250	TMP90C841AN/AF				1	6		4	1	●		●														–	SDIP64, QFP64	
		TMP90C845AN/AF				1	4		4	1	●		●				●										–	DIP40, SOP40	
	512	TMP90CH03P/M	250			1			4	●																	–	DIP40, SOP40	
	250	TMP91C641N/F	Note 320			1	6		4	1	●		●														–	SDIP64, QFP64	
		TMP90CH45N/F				1	4		4	1	●		●				●										–	SDIP64, QFP64	
	320	TMP90C141N/F				1	8		4	1	●		●														–	SDIP64, QFP64	
	1K	TMP90CM37F/T		1	1	1	8	2	4	1	●	●	●								●						–	MFP80, PLCC84	
		TMP90CM39F/T		1	1	8		4	1	●		●									●						–	MFP80, PLCC84	
	250	TMP90CS37F/T		1	1	1	8	2	4	1	●	●	●								●						–	MFP80, PLCC84	
TMP90CS39F/T			1	1	8		4	1	●		●									●						–	MFP80, PLCC84		
4K	TMP90C441N/F				1	6		4	1	●		●														–	SDIP64, QFP64		
4K	128	TMP90C400N/F			1			4															4.5 to 5.5	–20 to 70	TMP90P800N/F	SDIP64, QFP64			
8K	256	TMP90C800N/F	Note 320					4																		TMP90P802AP/AM	DIP40, SOP40		
		TMP90C802AP/AM						4	●																	TMP91P640N/F	SDIP64, QFP64		
	TMP90C840AN/AF				1	6		4	1	●		●														TMP90PH44N/F	SDIP64, QFP64		
	TMP90C844AN/AF	250			1	4		4	1	●		●								●						TMP90PH48F	QFP80		
512	TMP90C848F	400	1			16	4	1	●	8																TMP90PH48F	QFP80		
16K	320	TMP91C642AN/AF	400	2		12		4	●	3	●	●	●														TMP91P642N/F	SDIP64, QFP64	
		TMP90CH02P/M	250			1		4	●																		TMP90PH02P/M	DIP40, SOP40	
	512	TMP91C640N/F	Note 320			1	6		4	1	●		●														TMP91P640N/F	SDIP64, QFP64	
	TMP90CH44N/F	250			1	4		4	1	●		●								●							TMP90PH44N/F	SDIP64, QFP64	
640	TMP90CH42DF	320	2		6		3	●	3	●	●	●														TMP90PM42DF	QFP100		
24K	640	TMP90CK42DF	320	2		6		3	●	3	●	●	●														TMP90PM42DF	QFP100	
		TMP90CK76DF		2		12		4	●	3	●	●	●														TMP90PS74DF	QFP100	
32K	1K	TMP90CM36F/T	250	1	1	1	8	2	4	1	●	●	●							●							TMP90PM36F/T	MFP80, PLCC84	
		TMP90CM38F/T		1	1	8		4	1	●		●									●							TMP90PM38F/T	MFP80, PLCC84
	TMP90CM40AN/AF	Note 320			1	6		4	1	●		●															TMP90PM40E/N/F	SDIP64, QFP64	
40K	768	TMP90CN72EDF		2		12		4	●	3	●	●	●														TMP90PS74DF	QFP100	
60K	1K	TMP90CS74EDF		2		1	12		4	●	3	●	●	●														TMP90PS74DF	QFP100
		TMP90CS36F/T	250	1	1	1	8	2	4	1	●	●	●							●								TMP90PS36F	MFP80, PLCC84
	TMP90CS38F/T		1	1	8		4	1	●		●									●								TMP90PS38F	MFP80, PLCC84

Note: Guaranteed minimum instruction execution time is 320 ns when device is operating at temperatures of –20° to 70°C, and 400 ns when device is operating at temperatures of –40° to 85°C.

Product number suffixes: N: Plastic shrink dual in-line package (SDIP) F: Plastic quad flat package (QFP) P: Plastic standard dual in-line package (DIP)  
M: Plastic small-outline package (SOP) T: Plastic leaded chip carrier (PLCC) E: Ceramic standard dual in-line package (SDIC)

## 8-Bit Microcontrollers

# 870 Family

**8-bit microcontrollers suitable for a wide range of consumer electronic appliances such as TVs, VCRs and telephones**

The **870** Family is made up of microcontrollers which are suitable for consumer electronic equipment such as TVs, audio equipment and telephones. Every device in this family has an AD converter, LCD drive circuit, UART and on-screen display circuit. However, each device also has unique features particularly suiting it to certain well-defined applications and operating conditions. For example, the **870** Family product line includes devices with low-voltage, low power consumption and low-noise operation features, and these are suited to a wide range of portable equipment.

In addition to the popular **870** Series, Toshiba have recently introduced the **870/X** Series with improved functionality. To round out the **870** Family, Toshiba are currently developing the **870/C** Series for small-scale applications.

### Application core development

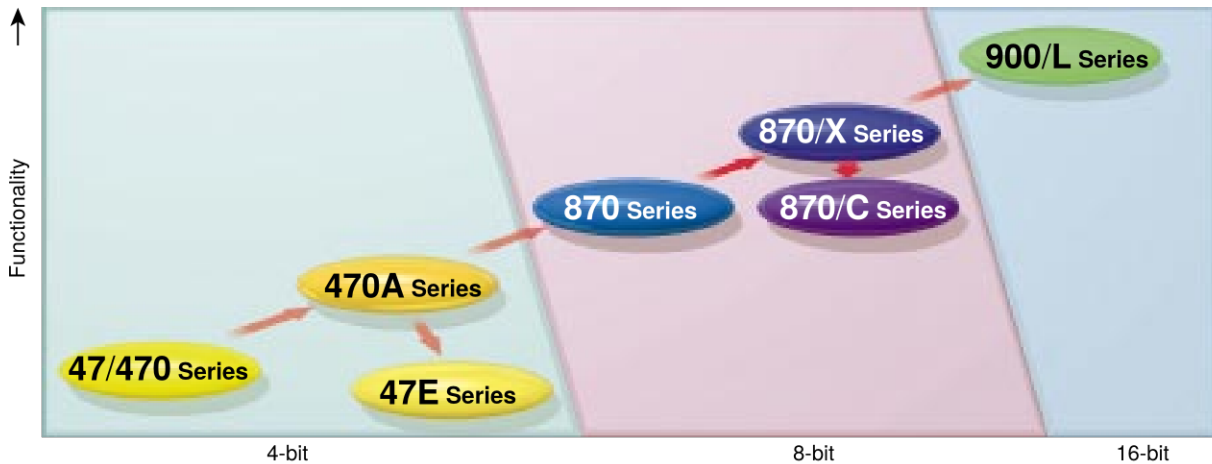

### Instruction set features

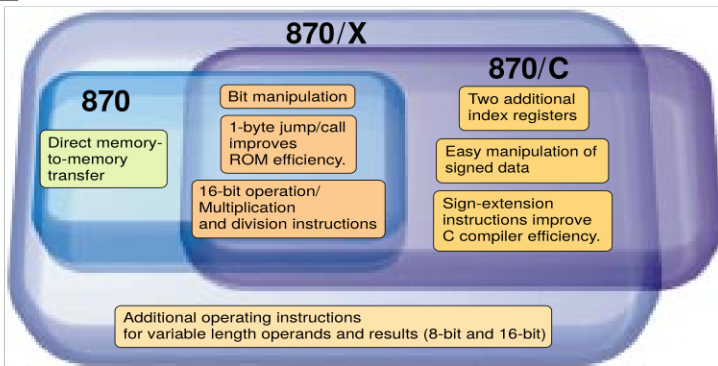

### Comparative performance

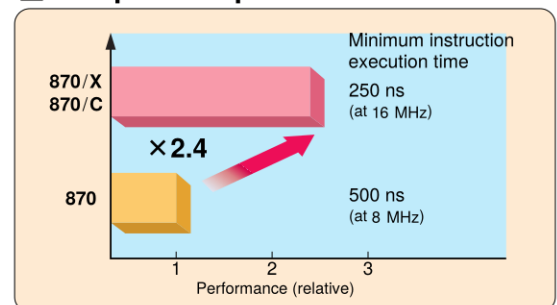

### Register configuration (870 and 870/X)

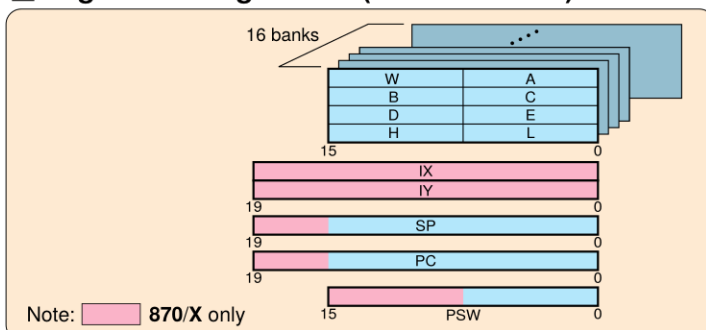

### Memory map

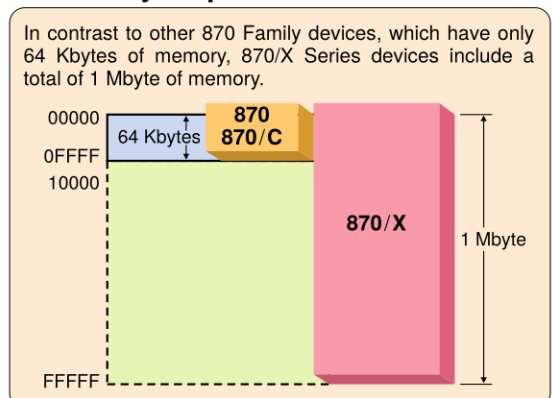

# 870 Family

# 870 Series



## Basic functions

- **64 Kbytes of memory space**
  - From 4 Kbytes to 60 Kbytes of ROM
  - From 256 bytes to 2 Kbytes of RAM
- **Architecture suitable for real-time control**
  - 0.5  $\mu$ s per instruction cycle at 8 MHz
  - High-speed task switching
    - High-speed Interrupt Register save/restore using register bank switching
  - Up to 15 interrupt vectors
- **Low-voltage, high-speed operation; low power consumption**
  - Wide operating voltage range: 2.7 V to 5.5 V or 2.7 V to 6.0 V (standard type)
  - 1.8 V / 0.95  $\mu$ s at 4.2 MHz (low-voltage type)
  - Clock gear
    - Low power consumption modes attained by switching the speed of the system clock.
  - Low-voltage AD conversion
  - Dual clock system
    - Main clock for high-speed operation (8 MHz)
    - and sub-clock for low power consumption (32.8 kHz); 5 different low power consumption modes
- **Instruction set for embedded controller: 412 instructions**
  - 1-byte jump/call instructions, direct memory-to-memory transfer instructions and arithmetic instructions to improve memory efficiency
  - Variety of bit-manipulation instructions
  - 16-bit transfer/calculation instructions
  - Multiplication and division instructions
- **One-time PROM product versions**
  - One-time PROM product versions with features compatible with mask ROM products
- **Small package**
  - Microflat package/Miniflat package
- **Well-developed support environment**
  - Assembler
  - High-level languages (C compiler, C-Like compiler)
  - High-level language debugger
  - Real-time emulator: RTE Model 10

## Register configuration

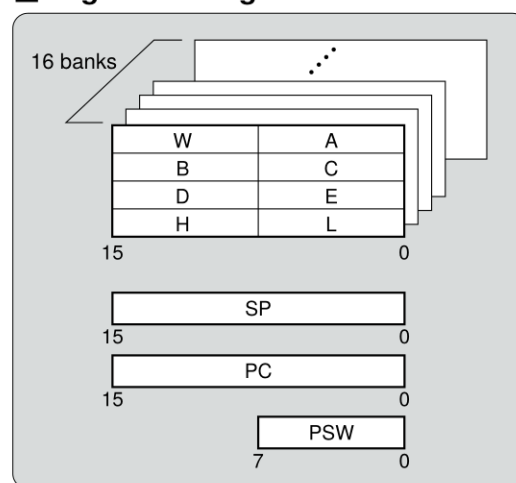

## Wide temperature range performance

Special products with a guaranteed operating temperature range of from  $-40^{\circ}$  to  $85^{\circ}\text{C}$  can also be supplied. If you are interested in using them, please contact your nearest Toshiba office or authorized Toshiba dealer.



# 870 Series Selection Guide

ROM (bytes)	RAM (bytes)	Product No.	Minimum Instruction Execution Time (μs)	Driver LED	VFT	SIO Channels	UART Channels	I <sup>2</sup> C Bus Channels Note 2	High-Speed Serial Output	AD Converter 8-bit channels	AD Converter Input 10-bit channels	DA Converter Channels	Timer/Counter 16-bit channels	8-bit channels	18-bit channels	Watchdog Timer Remote Control Pulse Detector	OSD	Dual Clock	Clock Gear	Number of I/O Ports	Power Supply Voltage (V)	Operating Temperature (°C)	Version with Built-in OTP	Packages				
4K	256	*TMP87C405AM/AN	0.50	6									2			●				22	4.5 to 5.5 2.7 to 5.5	-30 to 70	TMP87P808M/N	SOP28/ SDIP28				
		TMP87C408M/N/DM	0.95	6		1			6					2			●				22		1.8 to 4.0	TMP87P808M/N	SSOP30/ SOP28/ SDIP28			
		TMP87C408LM/LN	0.95	6		1			6					2			●				22		4.5 to 5.5 2.2 to 5.5	TMP87P808LM/LN				
		TMP87C409M/N	0.50 0.95	6				1		8				1	2		●						34	4.5 to 5.5	*TMP87P809M/N			
		TMP87C444N	0.50			1		1		4		8		2			●						34	4.5 to 5.5	TMP87P844N	SDIP42		
8K	512	TMP87C446N	0.50/122	8		1			●	8			2	2		●					35	4.5 to 5.5 2.7 to 5.5	TMP87PH46N	SDIP42				
		TMP87C447U		8		1			●	8				2	2		●					37	4.5 to 5.5 2.7 to 5.5	TMP87PH47U	μQFP44 (10 × 10 mm)			
	256	TMP87C800N/F/DF	0.50/122 0.95/122	8			2							2	2		●					58	4.5 to 6.0 2.7 to 6.0	TMP87PH00N/F/DF	SDIP64/ QFP64/ LQFP64			
		TMP87C807U	0.50 0.95	8		1				●				2	2		●					37	4.5 to 5.5 2.7 to 5.5	TMP87PH47U	μQFP44 (10 × 10 mm)			
		TMP87C808M/N		6		1				6				2			●					22	1.8 to 4.0	TMP87P808M/N	SOP28/ SDIP28			
		TMP87C808LM/LN	0.95	6		1			6					2			●					22	4.5 to 5.5 2.2 to 5.5	TMP87P808LM/LN				
		TMP87C809M/N	0.50 0.95	6				1		8				1	2		●						56	4.5 to 6.0 2.7 to 6.0	*TMP87P809M/N			
		TMP87C840N/F	0.50/122 0.95/122	8			2			8				2	2		●						56	4.5 to 6.0 2.7 to 6.0	TMP87PH40AN/AF	SDIP64/ QFP64		
		TMP87C841N/F/U	0.50/122 0.95/122	8				2			16			2	2		●						56	4.5 to 5.5 2.7 to 5.5	TMP87PM41N/F/U	SDIP64/ QFP64/ μQFP64 (10 × 10 mm)		
		TMP87C844N	0.50			1		1		4		8		2			●						34	4.5 to 5.5	TMP87P844N	SDIP42		
TMP87C814N/F	0.50/122 0.95/122			16	1			8				2	2		●						55	4.5 to 5.5 2.7 to 5.5	TMP87PM14N/F	SDIP64/ QFP64				
512	TMP87C846N	0.50/122 0.95/122	8		1			●	8				2	2		●						35	4.5 to 5.5 2.7 to 5.5	TMP87PH46N	SDIP42			
	TMP87C847U	0.95/122	8		1			●	8				2	2		●						37	1.8 to 4.0	TMP87PH47U	μQFP44 (10 × 10 mm)			
	TMP87C847LU	0.95/122	8		1			●	8				2	2		●						37	1.8 to 4.0	TMP87PH47LU	μQFP44 (10 × 10 mm)			
	TMP87C847LU	0.95/122	8		1			●	8				2	2		●						37	1.8 to 4.0	TMP87PH47LU	μQFP44 (10 × 10 mm)			
12K	256	TMP87CC31N	0.50	4								4	2	2		●	●					34	4.5 to 5.5	TMP87P844N	SDIP42			
		TMP87CC20F	0.50/122 0.95/122	2	32	1								1	4		●					45	4.5 to 6.0 2.7 to 6.0	TMP87PH20F	QFP80			
	TMP87CC40N/F	8						8					2	2		●						56	4.5 to 6.0 2.7 to 6.0	TMP87PH40AN/AF	SDIP64/ QFP64			
	TMP87CC41N/F/U	8				2			16				2	2		●						56	4.5 to 5.5 2.7 to 5.5	TMP87PM41N/F/U	SDIP64/ QFP64/ μQFP64 (10 × 10 mm)			
	TMP87CC78F	0.95/122			40	2			8				2	2		●						89	4.5 to 5.5 2.7 to 5.5	TMP87PM78F	QFP100			
16K	256	TMP87CH00N/F/DF	0.50/122 0.95/122	8									2	2		●						58	4.5 to 6.0 2.7 to 6.0	TMP87PH00N/F/DF	SDIP64/ QFP64/ LQFP64			
		TMP87CH00LF		4			2							2	2		●						58	4.5 to 5.5 1.8 to 5.5	TMP87PH00LF	QFP64		
		TMP87CH31N	0.50	4								4		2	2		●	●					34	4.5 to 5.5	TMP87PM36N	SDIP42		
	512	TMP87CH14N/F	0.50/122 0.95/122			16	1			8				2	2		●						55	4.5 to 5.5 2.7 to 5.5	TMP87PM14N/F	SDIP64/ QFP64		
		TMP87CH20F	0.95/122	2	32	1								1	4		●						45	4.5 to 6.0 2.7 to 6.0	TMP87PH20F	QFP80		
		TMP87CH38N/F	0.50	4				2		6				2	2		●	●					33	4.5 to 5.5	TMP87PS38N/F	SDIP42/ QFP44		
		TMP87CH40N/F	0.50/122 0.95/122	8			2			8				2	2		●						56	4.5 to 6.0 2.7 to 6.0	TMP87PH40AN/AF	SDIP64/ QFP64		
		TMP87CH41N/F/U		8			2			16				2	2		●						56	4.5 to 5.5 2.7 to 5.5	TMP87PM41N/F/U	SDIP64/ QFP64/ μQFP64 (10 × 10 mm)		
		TMP87CH46N	0.50/122 0.95/122	8		1			●	8				2	2		●							35	4.5 to 5.5 2.7 to 5.5	TMP87PH46N	SDIP42	
		TMP87CH47U		8		1			●	8				2	2		●							37	1.8 to 4.0	TMP87PH47U	μQFP44 (10 × 10 mm)	
		TMP87CH47LU	0.50/122 0.95/122	8		1			●	8				2	2		●							37	1.8 to 4.0	TMP87PH47LU	μQFP44 (10 × 10 mm)	
		TMP87CH48U/DF		8			1	1		16				2	2		●							56	4.5 to 5.5 2.7 to 5.5	TMP87PH48U/DF	μQFP64 (10 × 10 mm)/ LQFP64	
		†TMP87CH48IU	0.50/122 0.95/122	8			1	1		16				2	2		●							56	4.5 to 5.5 2.7 to 5.5	TMP87PH48U/DF	μQFP64 (10 × 10 mm)/ LQFP64	
		TMP87CH70BF				16	1			●	6			2	2		●							73	4.5 to 5.5 2.7 to 5.5	TMP87PM70F	QFP80	
		TMP87CH74AF	0.50/122 0.95/122	16		37	1	1		12				2	2		●							71	4.5 to 5.5 2.7 to 5.5	TMP87PM74F	QFP80	
		*TMP87CH75F		16		51	1	1		16				2	2		●							89	4.5 to 5.5 2.7 to 5.5	TMP87PM75F	QFP100	
		TMP87CH78F	0.50/122 0.95/122			40	2			8				2	2		●								89	4.5 to 5.5 2.7 to 5.5	TMP87PM78F	QFP100
		TMP87CH21F/DF				32	2			8				2	2		●								52	4.5 to 5.5 2.7 to 5.5	TMP87PP21F/DF	QFP80/ QFP80 (12 × 12 mm)
*TMP87CH21AF/ADF	0.50/122 0.95/122			32	2			8				2	2		●								52	4.5 to 5.5 2.7 to 5.5	TMP87PP21F/DF	QFP80/ QFP80 (12 × 12 mm)		
TMP87CH29N/U		3	24			1		5			1		4		●								43	4.5 to 5.5	TMP87PM29N/U	SDIP64/ μQFP64 (10 × 10 mm)		
TMP87CH34BN	0.50	4				2		4				2	2		●	●							33	4.5 to 5.5	TMP87PM34AN	SDIP42		
TMP87CH36N		4				1		4				2	2		●	●							34	4.5 to 5.5	TMP87PM36N	SDIP42		

 Purchase of TOSHIBA I<sup>2</sup>C components conveys a license under the Philips I<sup>2</sup>C Patent Rights to use these components in an I<sup>2</sup>C system, provided that the system conforms to the I<sup>2</sup>C Standard Specification as defined by Philips.

## 870 Series Selection Guide

ROM (bytes)	RAM (bytes)	Product No.	Minimum Instruction Execution Time (μs)	Driver		SIO Channels	UART Channels	I <sup>2</sup> C Bus Channels (Note 2)	High-Speed Serial Output	AD Converter 8-bit channels	AD Converter Input 10-bit channels	DA Converter Channels	Timer/Counter 16-bit channels	8-bit channels	Remote Control Pulse Detector	Watchdog Timer	OSD	Dual Clock	Clock Gear	Number of I/O Ports	Power Supply Voltage (V)	Operating Temperature (°C)	Version with Built-in OTP	Packages				
				LED	VFT																							
24K	512	TMP87CK38N/F	0.50	4			2	6					2	2	●	●	●			33	4.5 to 5.5	-30 to 70	TMP87PS38N/F*	SDIP42/QFP44				
		TMP87CK14N/F	0.50/122		16	1		8						2	2	●	●	●		55	4.5 to 5.5		TMP87PM14N/F	SDIP64/QFP64				
		TMP87CK20AF	0.95/122	2	32	1		8						1	4	●	●	●		45	2.7 to 5.5		TMP87PM20F	QFP80				
		TMP87CK29N/U		3	24		1	5					1	4	●	●	●			43			TMP87PM29N/U	SDIP64/μQFP64 (10 x 10 mm)				
		TMP87CK34BN	0.50	4			2		4					2	2	●	●	●		33	4.5 to 5.5		TMP87PM34AN	SDIP42				
		TMP87CK36N		4			1		4					2	2	●	●	●		34			TMP87PM36N					
		TMP87CK40AN/AF		8		2		8						2	2	●	●	●		56	4.5 to 6.0		TMP87PM40AN/AF	SDIP64/QFP64				
		TMP87CK41N/F/U		8		2		16						2	2	●	●	●						-40 to 85	TMP87PM41N/F/U	SDIP64/QFP64/μQFP64 (10 x 10 mm)		
		TMP87CK43N					2	6						2	2	●	●	●		35						TMP87PM43N	SDIP42	
		TMP87CK78F				40	2		8					2	2	●	●	●		89						*TMP87PM78F	QFP100	
32K	512	TMP87CM70BF	0.50/122		16	1	●	6					2	2	●	●	●			73	4.5 to 5.5	-30 to 70	TMP87PM70F	QFP80				
		TMP87CM14N/F	0.95/122		16	1		8					2	2	●	●	●			55	2.7 to 5.5		TMP87PM14N/F	SDIP64/QFP64				
		TMP87CM20AF		2	32	1								1	4	●	●	●		45			TMP87PM20F	QFP80				
		TMP87CM21F/DF		1	32	2		8						2	2	●	●	●		52			TMP87PP21F/DF	QFP80/QFP80 (12 x 12 mm)				
		TMP87CM23F		1	40	2		8						2	2	●	●	●		70			TMP87PP23F	QFP100				
		TMP87CM29N/U		3	24		1	5					1	4	●	●	●		43						TMP87PM29N/U	SDIP64/μQFP64 (10 x 10 mm)		
		TMP87CM34BN	0.50	4			2		4					2	2	●	●	●		33	4.5 to 5.5		TMP87PM34AN	SDIP42				
		TMP87CM36N		4			1		4					2	2	●	●	●		34			TMP87PM36N					
		TMP87CM38N/F		4			2	6						2	2	●	●	●		33						TMP87PS38N/F	SDIP42/QFP44	
		TMP87CM39N	0.50/122	4			2	8						2	2	●	●	●		55						TMP87PS39N	SDIP64	
		TMP87CM40AN/AF		8		2		8						2	2	●	●	●		56						TMP87PM40AN/AF	SDIP64/QFP64	
		TMP87CM41N/F/U	0.50/122	8		2		16						2	2	●	●	●		56	4.5 to 5.5		-40 to 85	TMP87PM41N/F/U	SDIP64/QFP64/μQFP64 (10 x 10 mm)			
		TMP87CM43N	0.95/122				2	6						2	2	●	●	●		35						TMP87PM43N	SDIP42	
		TMP87CM45N	0.50/122	4			2	8						2	2	●	●	●		55						TMP87PS39N	SDIP64	
		*TMP87CM48U/DF		8		1	1	16						2	2	●	●	●		56						-40 to 85	TMP87PM48U/DF	μQFP64 (10 x 10 mm)/LQFP64
		TMP87CM53F		7		1	1	8						2	2	●	●	●		72	4.5 to 5.5		-30 to 60	TMP87PM53F	QFP80			
		TMP87CM64F		16		3		16						2	3	●	●	●		90						TMP87PS64F	QFP100	
		TMP87CM74AF		16	37	1	1	12						2	2	●	●	●		71						TMP87PM74F	QFP80	
		*TMP87CM75F		16	51	1	1	16						2	2	●	●	●		89	4.5 to 5.5					TMP87PM75F	QFP100	
		TMP87CM78F	0.50/122		40	2		8						2	2	●	●	●								TMP87PM78F		
1.5K	TMP87CM71F	0.95/122		16	1	●	6					2	2	●	●	●			73					TMP87PS71F	QFP80			
2K	TMP87CM24AF		1	40	2		8					2	2	●	●	●		69	4.5 to 5.5				*TMP87PP24AF	QFP100 (14 x 14 mm)				
40K	1.5K	TMP87CN71F			16	1	●	6				2	2	●	●	●			73	4.5 to 5.5	-30 to 70	TMP87PS71F	QFP80					
48K	1.5K	TMP87CP71F			16	1	●	6				2	2	●	●	●			73	2.7 to 5.5		TMP87PP23F	QFP100					
		TMP87CP23F			40	2		8					2	2	●	●	●		70						TMP87PP24AF	QFP100 (14 x 14 mm)		
		TMP87CP24AF			1	40	2		8					2	2	●	●	●		69		4.5 to 5.5			*TMP87PP24AF	QFP100 (14 x 14 mm)		
		TMP87CP38N/F	0.50	4			2	6					2	2	●	●	●		33	4.5 to 5.5		TMP87PS38N/F	SDIP42/QFP44					
		TMP87CP39N	0.50/122	4			2	8					2	2	●	●	●		55	4.5 to 5.5		TMP87PS39N	SDIP64					
		TMP87CP64F	0.50/122	16		3		16						2	3	●	●	●		90		2.7 to 5.5	TMP87PS64F	QFP100				
		60K	2K	TMP87CS38N/F	0.50	4			2	6	6			2	2	●	●	●				33	4.5 to 5.5	TMP87PS38N/F	SDIP42/QFP44			
				TMP87CS39N	0.50/122	4			2	8					2	2	●	●	●			55	4.5 to 5.5	TMP87PS39N	SDIP64			
TMP87CS64F	0.50/122			16		3		16					2	3	●	●	●		90	4.5 to 5.5		TMP87PS64F	QFP100					
TMP87CS68DF	0.50/122			7		1	1	8					2	2	●	●	●		72	2.7 to 5.5	TMP87PS68DF	QFP80 (12 x 12 mm)						
TMP87CS71F	0.95/122				16	1		6					2	2	●	●	●		73					TMP87PS71F	QFP80			

\*: Under development  
 ★: Samples available  
 †: I/W version

Note 1: Product number suffixes    N: Plastic shrink dual in-line package (SDIP)    F: Plastic quad flat package (QFP)  
 M: Plastic small-outline package (SOP)    U: Plastic microflat package (μQFP)

Note 2: I<sup>2</sup>C bus circuit can be switched between I<sup>2</sup>C bus circuit and SIO circuit in software.  
 Note 3: USP 4,382,279 owned by BULL CP8.

◆ For further information about the I/W version, please contact your nearest Toshiba office or authorized Toshiba dealer.  
 ◆ OTP products are provided for system development and evaluation.

# 870 Family 870/C Series

*Suitable for home appliances and cellular equipment which require low-voltage operation capability and low power consumption*

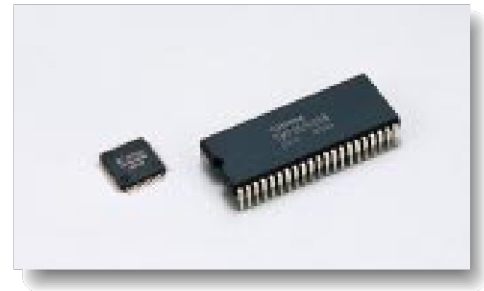

## Basic functions

- **64 Kbytes of memory space**
  - ROM-less version and versions including up to 60 Kbytes of ROM (all devices at planning stage)
- **Architecture suitable for real-time control**
  - 0.25  $\mu$ s per instruction cycle at 16 MHz
  - Up to 15 interrupt vectors (23 with multiplexing between interrupt sources)
- **Low-voltage, high-speed operation; low power consumption**
  - Wide operating voltage range: 1.8 V to 5.5 V (standard type)
  - Reduced power consumption (2/3 less than the TLCS-870)
  - Clock gear  
High-frequency clock (6 types), low-frequency clock (1 type)
- **Instruction set for embedded controller: 731 instructions**
  - Registers: isolated from memory space
  - Variety of bit-manipulation instructions
  - 16-bit transfer/calculation instructions
  - Multiplication and division instructions
- **One-time PROM or flash E<sup>2</sup>PROM product versions**
  - PROM or E<sup>2</sup>PROM product versions with features compatible with those of mask ROM products
- **Small package**
  - Microflat package/Miniflat package
- **Measures to combat electrical noise**
  - Reduced spontaneous noise, resistance to noise
- **Improved compilation of C source code**  
(30% reduction in source code size compared to TLCS-870 and TLCS-870/X)

## Register configuration

(Only a single general register bank is shown here.)

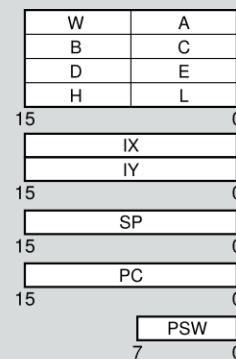

## Comparison of power consumption levels

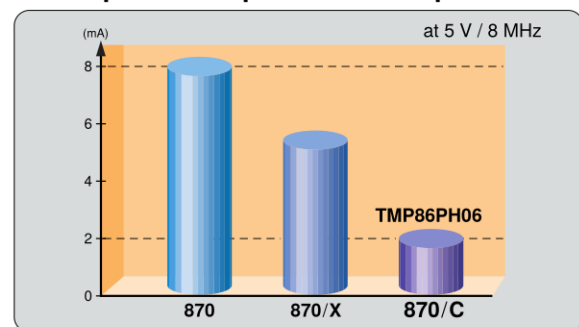

## 870/C Series Selection Guide

ROM (bytes)	RAM (bytes)	Product No.	Minimum Instruction Execution Time ( $\mu$ s)	Driver		Number of SIO Channels	AD Converter			Timer/Counter				Remote Control Pulse Detector	Watchdog Timer	Dual Clock	Clock Gear	Number of I/O Ports	Power Supply Voltage (V)	Operating Temperature ( $^{\circ}$ C)	Version with Built-in OTP	Packages
				LED	VFT		8-bit channels	10-bit channels	18-bit channels	16-bit channels	8-bit channels	8-bit channels	8-bit channels									
4K	256	*TMP86C420U/F	0.25/122	4	32	1	8	1	2	●	●											
		*TMP86C820U/F		4	32	1	8	1	2	●	●										*TMP86PM29U/F	$\mu$ QFP64 (10 x 10 mm) LQFP64
*TMP86C829U/F	4	32		(Note 3) 1	8	1	4	●	●													
*TMP86CH06N/U	8			(Note 2) 2		1	2	●	●	●											*TMP86PH06N/U	SDIP42/ $\mu$ QFP44
*TMP86CH29U/F	4	32		(Note 3) 1	8	1	4	●	●													
*TMP86CM29U/F	4	32		(Note 3) 1	8	1	4	●	●													*TMP86PM29U/F

\* Under development

Note 1: Product number suffixes N: Plastic shrink dual in-line package (SDIP) F: Plastic quad flat package (QFP) U: Plastic microflat package ( $\mu$ QFP)

Note 2: Either of the two UART channels can be selected in software as the SIO channel.

Note 3: SIO circuit or UART can be selected in software.

# 870 Family 870/X Series



## Basic functions

- **1-Mbyte memory space**
  - Planned products range from devices without any ROM to others with high-capacity ROMs.
- **Architecture suitable for real-time control**
  - 0.25  $\mu$ s per instruction cycle at 16 MHz
  - High-speed task switching
    - High-speed Interrupt Register save/restore using automatic register bank switching
  - Up to 63 interrupt vectors
- **Low-voltage, high-speed operation; low power consumption**
  - Wide operating voltage range: 2.7 V to 5.5 V (standard type)
  - 1.8 V / 0.95  $\mu$ s at 4.2 MHz (low-voltage type)
  - Dual clock system
    - Main clock for high-speed operation (16 MHz)
    - and sub-clock for low-power operation (32.768 kHz)
  - Power consumption can be reduced by changing the instruction execution speed.
- **Instruction set for embedded controller: 842 instructions**
  - 1-byte jump/call instructions, direct memory-to-memory transfer instructions and arithmetic instructions to improve memory efficiency
  - Variety of bit-manipulation instructions
  - 16-/20-bit transfer/operation instructions
  - Multiplication and division instructions (16  $\times$  8, 16/8)
  - Enhanced arithmetic, logic, bit-manipulation and sign-handling instructions
  - Additional instructions to improve the efficiency of the C compiler in generating object code
- **One-time PROM product versions**
  - One-time PROM product versions with features compatible with mask ROM products
- **Well-developed support environment**
  - Assembler
  - High-level languages (C compiler, C-Like compiler)
  - High-level language debugger
  - Real-time emulator: RTE Model 25

## Register configuration

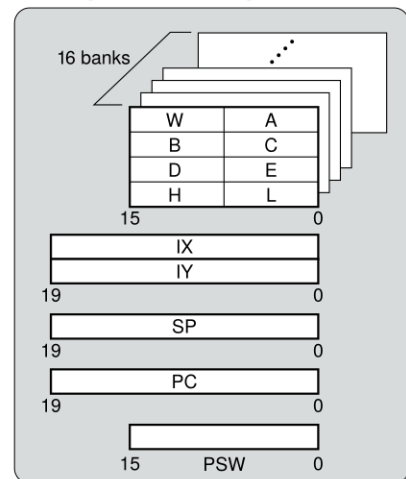

## 870/X Series Selection Guide

ROM (bytes)	RAM (bytes)	Product No.	Minimum Instruction Execution Time ( $\mu$ s)	Driver			SIO Channels	UART Channels	I <sup>2</sup> C Bus Channels	AD Converter	Timer/Counter	Motor Control	External Memory Interface	E-PROM	Remote Control Pulse Detector	Watchdog Timer	Dual Clock	Clock Gear	Number of I/O Ports	Power Supply Voltage (V)	Operating Temperature (°C)	Version with Built-in OTP	Packages
				LED	VFT	LCD																	
NA	512	TMP88C060F	0.32/122 0.95/122	8			1	1	8	2	4	●	●	●	●	●	●	42	4.5 to 5.5 2.7 to 5.5	-40 to 85	-	QFP80 (12 $\times$ 12 mm)	
16K		*TMP88CH21F/DF	0.5/122 0.95/122		40	1	1	8	2	2						●	●	●	47		4.5 to 5.5 2.7 to 4.5	*TMP88PM21F/DF	QFP80/ LQFP80 (12 $\times$ 12 mm)
24K	1K	TMP88CH47N/F	0.25	8			1	1	8	2	1	1				●		34	4.5 to 5.5	*TMP88PH47N/F	SDIP42/ QFP44		
		TMP88CK48N/F		8			1	1	16	2	2	1				●		56		TMP88PS49N/F	SDIP64/ QFP64		
32K	1K	*TMP88CM21F/DF	0.5/122 0.95/122		40	1	1	8	2	2						●	●	●	47	4.5 to 5.5 2.7 to 4.5	*TMP88PM21F/DF	QFP80/ LQFP80 (12 $\times$ 12 mm)	
		TMP88CM48N/F	0.25	8			1	1	16	2	2	1				●		56	4.5 to 5.5	TMP88PS49N/F	SDIP64/ QFP64		
96K	2K	TMP88CU74F		0.32/122	37			1	1	12	2	2				●	●	71	4.5 to 5.5 2.7 to 5.5	-30 to 70	TMP88PU74F	QFP80	

\* Under development  
★: Samples available

Note 1: Product number suffixes N: Plastic shrink dual in-line package (SDIP)  
Note 2: I<sup>2</sup>C bus circuit or SIO circuit can be selected in software.

F: Plastic quad flat package (QFP)

# NEW PRODUCTS

870 Series device with built-in UART & key-on wake-up function

NEW

## TMP87CS68DF

### 8-bit microcontroller suitable for communications equipment with UART and key-on wake-up function

The **TMP87CS68DF** has high ROM and RAM capacities, includes a UART, and incorporates a key-on wake-up function. It is housed in a small package (12 mm × 12 mm) and is suitable for pagers, telephones and other communications equipment.

In addition, it has a clock gear system which can keep power consumption low.

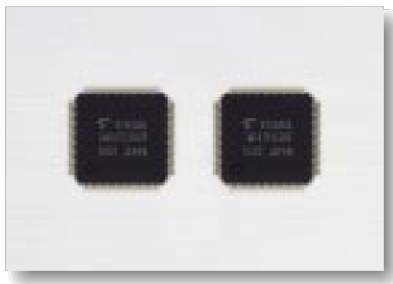

(Actual size)

- Internal ROM: 60 Kbytes
- Internal RAM: 2 Kbytes
- I/O ports: 72
- Minimum instruction execution time:
  - 0.50  $\mu$ s (at 8 MHz and 4.5 V to 5.5 V)
  - 0.95  $\mu$ s (at 4.2 MHz and 2.7 V to 5.5 V)
- LED driver: 7 channels
- Key-on wake-up: 8 channels
- Low power consumption modes (attained using clock gearing)
- 8-bit AD converter: 8 channels
- 16-bit timer/counter: 2 channels
- 8-bit timer/counter: 2 channels
- 8-bit serial interface
  - UART: 1 channel
  - Synchronous SIO: 1 channel
- 80-pin QFP (12 mm × 12 mm)
- OTP version: **TMP87PS68DF**

870 Series device with built-in AD converter and clock gear

NEW

## TMP87C408DM

### Small-package version of TMP87C408M with clock gear for low power consumption

The **TMP87C408DM** is a small-package version of the **TMP87C408M** featuring ROM and RAM capacities, input/output ports, multi-function timer/counters, a serial interface and an AD converter.

In addition, it has a clock gear system which can keep power consumption low.



Package size comparison (actual size)

- Internal ROM: 4 Kbytes
- Internal RAM: 256 bytes
- I/O ports: 22
- Minimum instruction execution time:
  - 0.50  $\mu$ s (at 8 MHz and 4.5 V to 5.5 V)
- 8-bit AD converter: 6 channels
- 16-bit timer/counter: 2 channels
- 8-bit serial interface
  - Synchronous SIO: 1 channel
- Timebase timer
- Watchdog timer
- 30-pin SSOP
- OTP version: **TMP87P808M** (28-pin SOP)

# NEW PRODUCTS

870 Series device with built-in UART and 10-bit AD converter

**NEW**

## TMP87CM48U\*

\*Under development

### ■ Mini-package 8-bit microcontroller with low power consumption

The **TMP87CM48U** is an 8-bit microcontroller which incorporates a 10-bit AD converter, a UART/I<sup>2</sup>C bus interface and an advanced function timer which make it ideal for such applications as portable information terminal equipment, battery charging controllers and power supply monitoring control.

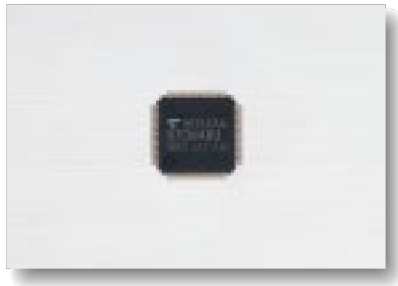

(Actual size)

- Internal ROM: 32 Kbytes
- Internal RAM: 1 Kbyte
- I/O port: 56 pins
- Minimum instruction execution time:
  - 0.50 μs (at 8 MHz and 4.5 V to 5.5 V)
  - 0.95 μs (at 4.2 MHz and 2.7 V to 5.5 V)
  - 122 μs (at 32.768 kHz and 2.7 V to 5.5 V)
- 10-bit AD converter: 16 channels
- DA conversion (pulse width modulation) output: 4 channels
- 8-bit serial interface
- UART: 1 channel
- I<sup>2</sup>C bus/Synchronous SIO: 1 channel
- 16-bit timer/counter: 2 channels
- 8-bit timer/counter: 2 channels
- Timebase timer
- Watchdog timer
- 64-pin μQFP package (10 mm × 10 mm)
- OTP version: **TMP87PM48U**

870/X Series devices with built-in LCD driver

**NEW**

## TMP88CH21F\*/DF\* TMP88CM21F\*/DF\*

\*Under development

### ■ Low-voltage 8-bit microcontrollers with built-in LCD driver

The **TMP88CH21/CM21** contain LCD driver circuitry which includes a voltage booster enabling them to continue to drive the LCD, even when battery power is low.

In Low Power Mode the microcontrollers reduce their own internal clock frequency (clock gear).



(Actual size)

- Internal ROM
  - TMP88CM21**: 32 Kbytes
  - TMP88CH21**: 16 Kbytes
- Internal RAM
  - TMP88CM21**: 1 Kbyte
  - TMP88CH21**: 512 bytes
- Minimum instruction execution time:
  - 0.50 μs (at 8 MHz and 4.5 V to 5.5 V)
  - 122 μs (at 32.768 kHz)
- LCD driver: LCD driver with voltage booster
  - 16 to 40 segment outputs
  - 4 common outputs
- 8-bit AD converter: 8 channels
- Low power consumption modes (attained using clock gearing)
- 16-bit timer/counter: 2 channels
- 8-bit timer/counter: 2 channels
- 8-bit serial interface
  - UART: 1 channel
  - Synchronous SIO: 1 channel
- AC zero-cross: 2 channels
- Key-on wake-up: 4 channels
- 80-pin QFP: 14 mm × 14 mm (0.65-mm pitch)  
12 mm × 12 mm (0.5-mm pitch)
- OTP version: **TMP88PM21F/DF\*** (under development)



Purchase of TOSHIBA I<sup>2</sup>C components conveys a license under the Philips I<sup>2</sup>C Patent Rights to use these components in an I<sup>2</sup>C system, provided that the system conforms to the I<sup>2</sup>C Standard Specification as defined by Philips.

# NEW PRODUCTS

870/X Series device with built-in VFT driver

NEW

## TMP88CU74F

### 8-bit microcontroller capable of programmable grid scan output

The **TMP88CU74F** is an 8-bit microcontroller with a VFT driver control circuit which provides programmable grid scan output. It features an 8-bit AD converter, an I<sup>2</sup>C bus interface and other features making it suitable for displays for audio and video equipment.



- Internal ROM: 96 Kbytes
- Internal RAM: 2 Kbytes
- I/O ports: 71
- Minimum instruction execution time:  
0.32  $\mu$ s (at 12.5 MHz and 4.5 V to 5.5 V)
- 8-bit AD converter: 12 channels
- 16-bit timer/counter: 2 channels
- 8-bit timer/counter: 2 channels
- Serial interface  
8-bit SIO and I<sup>2</sup>C bus: 1 channel each
- Watchdog timer
- 80-pin QFP
- Emulation pod: **BM88CU74F0A**
- OTP version: **TMP88PU74F**

870/X Series device with built-in motor controller

NEW

## TMP88CH47N/F\*

\* Under development

### High-speed 8-bit microcontroller with high memory capacity capable of controlling DC and AC motors

The **TMP88CH47N/F** is a high-speed 870/X Series product capable of operating at 0.25  $\mu$ s / 5.0 V and incorporating sensor/sensorless DC motor control capability, AC motor inverter control capability, a 10-bit AD converter and a serial interface.



- Internal ROM: 16 Kbytes
- Internal RAM: 512 bytes
- I/O port: 34 pins
- Minimum instruction execution time:  
0.25  $\mu$ s (at 16 MHz / 4.5 V to 5.5 V)
- Motor control circuits: 1 channel
- 10-bit AD converter: 8 channels
- 16-bit timer/counter: 2 channels
- 8-bit timer/counter: 1 channel
- Serial interface  
8-bit SIO/I<sup>2</sup>C bus: 1 channel  
UART: 1 channel
- Timebase timer
- Watchdog timer
- 42-pin SDIP / 44-pin QFP (14 mm × 14 mm)
- OTP version: **TMP87PH47N\*/F\***



Purchase of TOSHIBA I<sup>2</sup>C components conveys a license under the Philips I<sup>2</sup>C Patent Rights to use these components in an I<sup>2</sup>C system, provided that the system conforms to the I<sup>2</sup>C Standard Specification as defined by Philips.

## 4-Bit Microcontrollers

# 47 Family

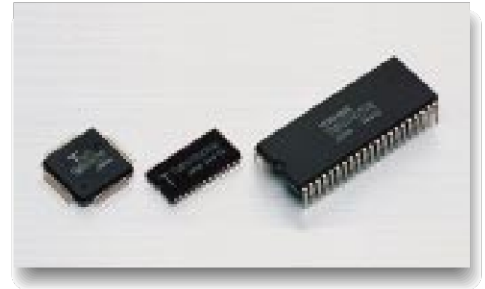

The 47 Family is made up of 4-bit microcontrollers which include various peripheral circuits. Devices with from 1 Kbyte to 16 Kbytes of built-in ROM are available. These devices are suitable for a variety of applications.

### Basic functions

- Instructions: maximum 105
- Minimum instruction execution time: 1.0  $\mu$ s
- ROM table look-up instructions
- 5-bit data to 8-bit data conversion instruction
- Subroutine nesting: maximum 15 levels
- Interrupt sources: 2 external, 4 internal
- Interval timer
- Serial interface

### Additional functions

- VFT driver
- LCD driver
- LED driver
- Hold function (low power consumption modes)
- Multi-pin input/output
- DA conversion (PWM) output
- AD conversion input
- AD converter input
- 16-bit high-speed event counter
- E<sup>2</sup>PROM
- On-screen display circuit
- DTMF generator
- DTMF receiver
- Watchdog timer
- Pulse generator
- Remote control pulse detector
- High-speed timer/counter
- Dual-clock system

### Core development

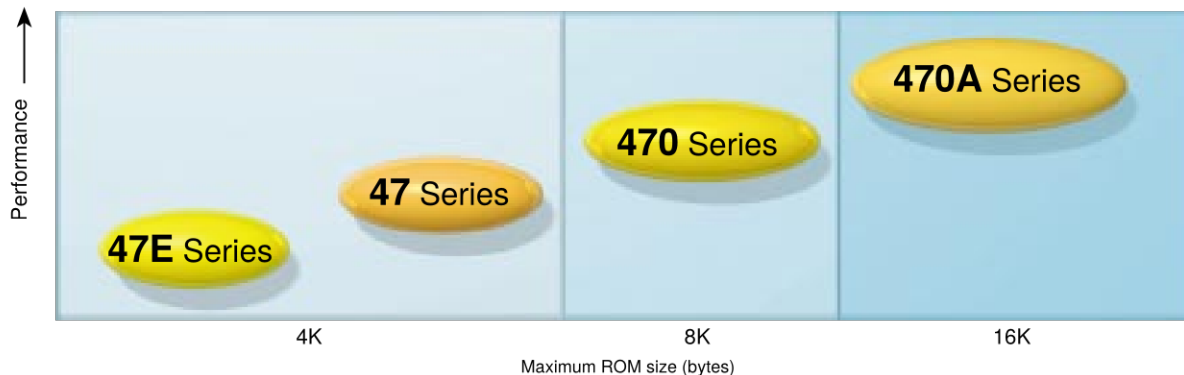

### Features

	47E Series	47 Series	470 Series	470A Series
Maximum ROM size (bytes)	4K × 8		8K × 8	16K × 8
Maximum RAM size (bytes)	256 × 4	768 × 4	1024 × 4	
Minimum instruction execution time	1.0 $\mu$ s (at 8 MHz, V <sub>DD</sub> = 2.7 V to 5.5 V) 1.3 $\mu$ s (at 6 MHz, V <sub>DD</sub> = 4.5 V to 5.5 V) 1.9 $\mu$ s (at 4.2 MHz, V <sub>DD</sub> = 2.7 V to 5.5 V) 3.2 $\mu$ s (at 2.5 MHz, V <sub>DD</sub> = 2.2 V to 5.5 V)	1.9 $\mu$ s (at 4.2 MHz, V <sub>DD</sub> = 4.5 V ~ 6 V)	1.3 $\mu$ s (at 6 MHz, V <sub>DD</sub> = 4.5 V ~ 5.5 V) 244 $\mu$ s (at 32.8 kHz, V <sub>DD</sub> = 2.7 V ~ 5.5 V)	
Number of instructions	90		92	105
Number of interrupts	5 or 6		6	
Packages	DIP16~DIP20    SOP16~SOP28 SDIP28~SDIP42    SSOP30 QFP44	SDIP30~SDIP42 QFP44~QFP80	SDIP28~SDIP64 QFP44~QFP100	SDIP42~SDIP64 QFP44~QFP80

### Wide temperature range performance

Special products with a guaranteed operating temperature range of -40° to 85°C are also provided. If you are interested in using them, please contact your nearest Toshiba office or authorized Toshiba dealer.



## ▶ 47E Series Selection Guide

ROM (bytes)	RAM (nibbles)	Product No.	Minimum Instruction Execution Time (µs)	Driver		SIO		AD Converter Channels	Pulse Output Channels	Watchdog Timer	E <sup>2</sup> PROM	Dual Clock	Hold Function	Number of I/O Ports	Wide Temperature Range	Power Supply Voltage (V)	Operating Temperature (°C)	Version with Built-in OTP	Packages		
				LED	LCD	4-bit channels	8-bit channels														
1K	64	TMP47C101P/M	1.3	4									●	11	2.2 to 5.5 Note 2	-30 to 70	TMP47P201VP	DIP16/ SOP16			
		*TMP47C101WP		4							●	11									
		TMP47C102P/M		4						●	15										
		TMP47C103N/M		8		1				●	23										
		† TMP47E186M								●	●	●		2.0 to 5.5					-40 to 85	TMP47P186M	SOP16
		† TMP47E187M								●	●	●		2.7 to 5.5							
2K	128	TMP47C201P/M	1.0	4									●	2.2 to 5.5 Note 2	-40 to 110	TMP47P201VP	DIP16/ SOP16				
		*TMP47C201WP		4							●										
		TMP47C202P/M		4						●	15										
		TMP47C203N/M		8		1				●	23										
		TMP47C206P/M		5			1	●	●	15		4.0 to 5.7	-40 to 85					TMP47P206VPVM	DIP20/ SOP20		
		TMP47C241N/M		5		1	4	●	●	21	●	2.7 to 6.0	-30 to 70					TMP47P241VN/VM	SDIP28/ SOP28		
	TMP47C241N/IM	5		1	4	●	●	21	●	2.7 to 6.0	-40 to 85										
	TMP47C241WM	5		1	4	●	●	21	●	2.7 to 6.0	-40 to 110										
	TMP47C243N/M/DM	8		1	8	1	●	●	23					TMP47P443VN/ VM/VDM	SDIP28/ SOP28/ SSOP30						
	4K	256	TMP47C222N/F	1.0 (244)	20		1	4	1	●		●	●	22	2.2 to 5.5	-30 to 70	TMP47P422VN/VF	SDIP42/ QFP44			
TMP47C422N/F			20			1	4	1	●		●	●	22								
TMP47C443N/M/DM			8			1	8	1	●		●	23		TMP47P443VN/ VM/VDM					SDIP28/ SOP28/ SSOP30		
†*TMP47E486M						1	4	●	●	●	21	2.7 to 5.5 Note 8	-40 to 85	*TMP47W486M					SOP28		
†*TMP47E487M			1	4	●	●	●	21	2.7 to 5.5	*TMP47W487M											

## ▶ 47 Series Selection Guide

ROM (bytes)	RAM (nibbles)	Product No.	Minimum Instruction Execution Time (µs)	Driver			SIO 4-bit channels	AD Converter Channels	Pulse Output Channels	Watchdog Timer	High-Speed Event Counter Channels	DTMF Generator	Dual Clock	Hold Function	Number of I/O Ports	Power Supply Voltage (V)	Operating Temperature (°C)	Version with Built-in OTP	Packages
				LED	LCD	VFT													
2K	128	TMP47C200BN/BF	1.9	8		1								●	36	2.7 to 6.0	-30 to 70	TMP47P400VN/VF	SDIP42/ QFP44
		TMP47C210AN/AF			20	1								●	35	4.5 to 6.0		TMP47P410AN/AF	SDIP42
		TMP47C212AN			20	1								●	35	4.5 to 6.0		–	SDIP42
		TMP47C242BN		8			4	1	●					●	23	2.7 to 6.0		TMP47P242VN	SDIP30
	192	TMP47C221ADF		24		1							●	28	4.5 to 6.0	TMP47P421ADF	QFP64		
4K	256	TMP47C400BN/BF	1.9	8		1								●	36	2.7 to 6.0	-30 to 70	TMP47P400VN/VF	SDIP42/ QFP44
		TMP47C410AN/AF			20	1								●	35	4.5 to 6.0		TMP47P410AN/AF	SDIP42
		TMP47C412AN			20	1								●	35	4.5 to 6.0		–	SDIP42
		TMP47C421ADF			24	1								●	28	4.5 to 6.0		TMP47P421ADF	QFP64
		TMP47C423ADF			24	1		1	1					●	28	4.5 to 6.0		–	QFP64
		TMP47C440BN/BF			8		1	8	●					●	34	2.7 to 5.5		TMP47P440VN/VF	SDIP42/ QFP44
	TMP47C441AN/AF			16	1	4	●					●	34	4.5 to 6.0	TMP47P441AN/AF	SDIP42/ QFP44			
	TMP47C446ADF	1.9 (244)		24		1	4	●				●	24	4.5 to 6.0	TMP47P446VDF	QFP64			
	768		TMP47C407AN/AF	2.1			1		1			●	●	35	2.7 to 6.0	-30 to 60	TMP47P407VN/VF	SDIP42/ QFP44	
			TMP47C451BN	16.7					1			●	●	23	2.2 to 6.0	-30 to 60	TMP47P451VN	SDIP30	
TMP47C452BN/BF						1		1			●	●	35	2.2 to 6.0	-30 to 60	TMP47P452VN/VF	SDIP42/ QFP44		
TMP47C453AN/AF			8.3			1		1			●	●	35	2.2 to 6.0	-30 to 60	TMP47P453VN/VF	SDIP42/ QFP44		
		TMP47C454AN	2.1					1			●	●	23	2.7 to 6.0	-30 to 60	TMP47P454VN	SDIP30		
		TMP47C456ADF	8.3 (244)	32		1		1	●		●	●	34	2.7 to 6.0	-30 to 60	–	QFP80		

## ▶ 470 Series Selection Guide

ROM (bytes)	RAM (nibbles)	Product No.	Minimum Instruction Execution Time (µs)	Driver			SIO 8-Bit Channels	AD Converter Channels	AD Conversion Input Channels	Pulse Output PWM channels	Pulse channels	Remote Control Pulse Detector	Watchdog Timer	DTMF Generator	Dual Clock	Hold Function	Number of I/O Ports	Power Supply Voltage (V)	Operating Temperature (°C)	Version with Built-in OTP	Package
				LED	LCD	VFT															
2K	128	TMP47C215N	1.0 (244)	1	23	1					●							4.5 to 5.5	-30 to 70	TMP47P415VN	SDIP42
		TMP47C216F		1	24	1			4			●									TMP47P416VF
4K	256	TMP47C415N	1.0 (244)	1	23	1					●							4.5 to 5.5	-30 to 70	TMP47P415VN	SDIP42
		TMP47C416F		1	24	1			4			●								TMP47P416VF	QFP44
6K	384	TMP47C620DF	1.3 (244)	8	32	1				1	●	2						4.5 to 6.0	-40 to 70	TMP47P820VDF	QFP80
		TMP47C640N/F		8		1	8				●	●								2.7 to 5.5	TMP47P840VN/VF
		TMP47C647F		8	32	1	8			1	●							4.5 to 6.0	TMP47P847VF	QFP80	
		TMP47C660AN/AF		8		1	8				●	●							2.7 to 5.5	TMP47P860VN/VF	SDIP64/ QFP64
		TMP47C662AN		4	27	1	8			2	●	●							4.5 to 6.0	TMP47P862VN	SDIP64
		TMP47C670N		8	28	1			4	1	●	●							4.5 to 6.0	TMP47P870N	SDIP64
896		TMP47C655F	8.3 (244)	32		1				1	●	●					2.2 to 6.0	-30 to 60	TMP47P855VF	QFP80	
8K	512	TMP47C800N/F	1.3 (244)	8		1					●							4.5 to 6.0	-40 to 70	TMP47P800N/F	SDIP42/ QFP44
		TMP47C820DF		8	32	1				1	●	2								TMP47P820VDF	QFP80
	TMP47C840N/F	8		1	8				●	●							2.7 to 5.5	-40 to 70	TMP47P840VN/VF	SDIP42/ QFP44	
	TMP47C847F	8	32	1	8			1	●								4.5 to 6.0	TMP47P847VF	QFP80		
	TMP47C850N/F	2.23 (244)	16		1			4		2	●		●					4.5 to 5.5	-30 to 60	TMP47P850VN/VF	SDIP64/ QFP64
	TMP47C858F	8.3 (244)	44		1								●					2.7 to 6.0	-	QFP100	
	TMP47C860AN/AF	1.3 (244)	8		1	8				●	●							2.7 to 5.5	-40 to 70	TMP47P860VN/VF	SDIP64/ QFP64
	TMP47C862AN	1.3 (244)	4	27	1	8			2	●	●							4.5 to 6.0	-40 to 70	TMP47P862VN	SDIP64
	TMP47C870N	1.3 (244)	8	28	1			4	1	●	●							4.5 to 6.0	-40 to 70	TMP47P870N	SDIP64
			†TMP47E885AIF	1.3			1	●	8	2		●	1		●	●	●		4.5 to 5.5	-40 to 85	TMP47P885F
		†TMP47E885WF	1.3			1	●	8	2		●	1		●	●	●		4.5 to 5.5	-40 to 110	TMP47P885F	QFP44
1024		TMP47C855AF	8.3 (244)	32		1				1	●	●					2.2 to 6.0	-30 to 60	TMP47P855VF	QFP80	

## ▶ 470A Series Selection Guide

ROM (bytes)	RAM (nibbles)	Product No.	Minimum Instruction Execution Time (µs)	Driver			SIO 8-Bit Channels	AD Converter Channels	AD Conversion Input Channels	Pulse Output PWM channels	Pulse channels	Remote Control Pulse Detector	Watchdog Timer	DTMF Generator	Dual Clock	Hold Function	Number of I/O Ports	Power Supply Voltage (V)	Operating Temperature (°C)	Version with Built-in OTP	Packages	
				LED	LCD	VFT																
4K	768	TMP47C457N/F	2.1 (244)				1			1	●						35	2.7 to 6.0	-30 to 60	TMP47P857VN/VF	SDIP42/ QFP44	
6K	384	TMP47C623F	1.3 (244)	4	24		1			1	●	1					32	4.5 to 6.0	-40 to 70	TMP47P823VF	QFP64	
	512	TMP47C823F		4	24		1			1	●	1					to 28			TMP47P823VF	QFP64	
8K	1024	TMP47C853N/F	8.3 (244)				1			1	●						35	2.2 to 6.0	-30 to 60	TMP47P853VN/VF	SDIP42/ QFP44	
		TMP47C857N/F	2.1 (244)				1			1	●							2.7 to 6.0	-30 to 60	TMP47P857VN/VF	QFP44	
12K	768	TMP47C1220F	1.3 (244)	8	32		1			1	●						36	4.5 to 6.0	-40 to 70	TMP47P1620VF	QFP80	
		TMP47C1260N/F		8			1	8			●	●								56	TMP47P1660VN/VF	SDIP64/ QFP64
		TMP47C1270AN		8	28	1		4	1		●	●	2							53	TMP47P1670VN	SDIP64
16K	768	TMP47C1620F	1.3 (244)	8	32		1			1	●						36	4.5 to 6.0	-40 to 70	TMP47P1620VF	QFP80	
		TMP47C1660N/F		8			1	8			●	●								56	TMP47P1660VN/VF	SDIP64/ QFP64
		TMP47C1670AN		8	28	1		4	1		●	●	2							53	TMP47P1670VN	SDIP64

\* Under development

Note 1: Product number suffixes P: Plastic standard dual in-line package (DIP) N: Plastic shrink dual in-line package (SDIP)  
M: Plastic small-outline package (SOP) F: Plastic quad flat package (QFP)

Note 2: When using CR circuit (2.7 V to 5.5 V when using resonator)

Note 3: TMP47E186M (CR version), TMP47E187M (resonator version)

Note 4: Numbers in ( ) show the minimum instruction execution time when operating at a low clock frequency.

Note 5: † USP 4,382,279 owned by BULL CP8.

Note 6: The CPU core used is that of the 470 Series.

Note 7: TMP47E486M (CR version), TMP47E487M (resonator version)

Note 8: The minimum operating voltage for the TMP47E486M has not yet been finalized.

◆ For further information about the I/W version, please contact your nearest Toshiba office or authorized Toshiba dealer.

◆ Products with an OTP are not available with a wide operating temperature range and are not designed for high-performance applications.

# Surface-Mount Package List

(comparison of surface area of small and large packages)

To meet customer needs Toshiba offer a wide range of highly reliable packages for high-density mounting, ranging from 16-pin to 160-pin products. In particular, Toshiba's miniature packages for portable applications anticipate customer needs for miniaturization by offering formats as compact as the 144-pin, 0.4-mm pitch format.

## SOPs/SSOPs for 4-/8-bit microcontrollers

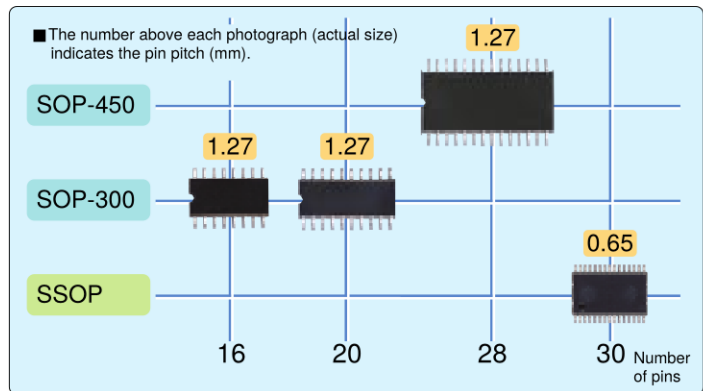

## QFPs for 4-/8-/16-bit microcontrollers

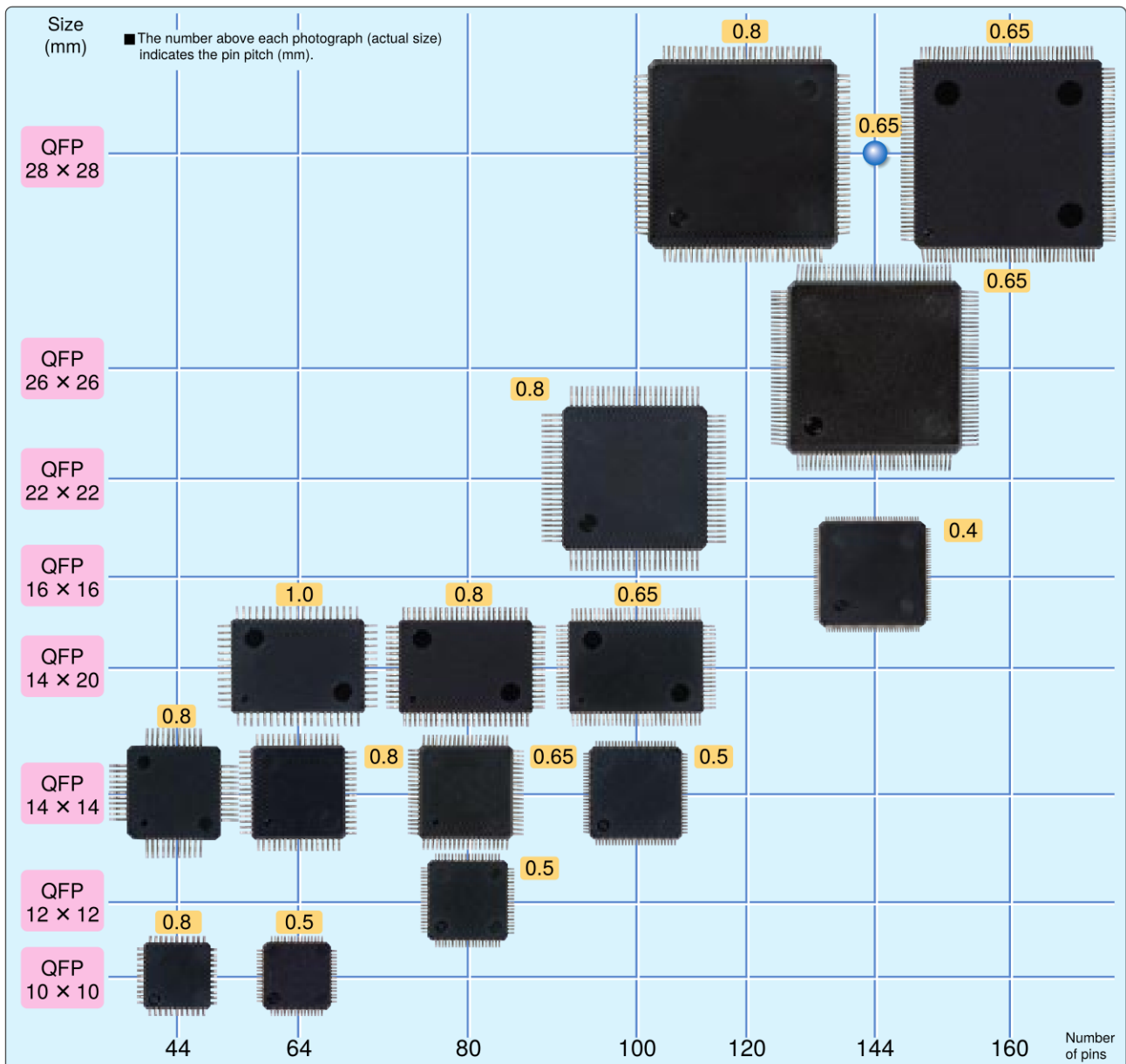

# Development Environment

Toshiba offer various integrated development systems which include language tools and evaluation tools. Toshiba call this the **Integrated Development Environment**.

In addition to original Toshiba development systems, various development support tools by third parties are also available. For details please refer to the **Microcomputer Development System Product Catalog**.

The chart below is a schematic representation of Toshiba's **Integrated Development Environment**.

■ Example of a development system environment (using RTE Model 25)

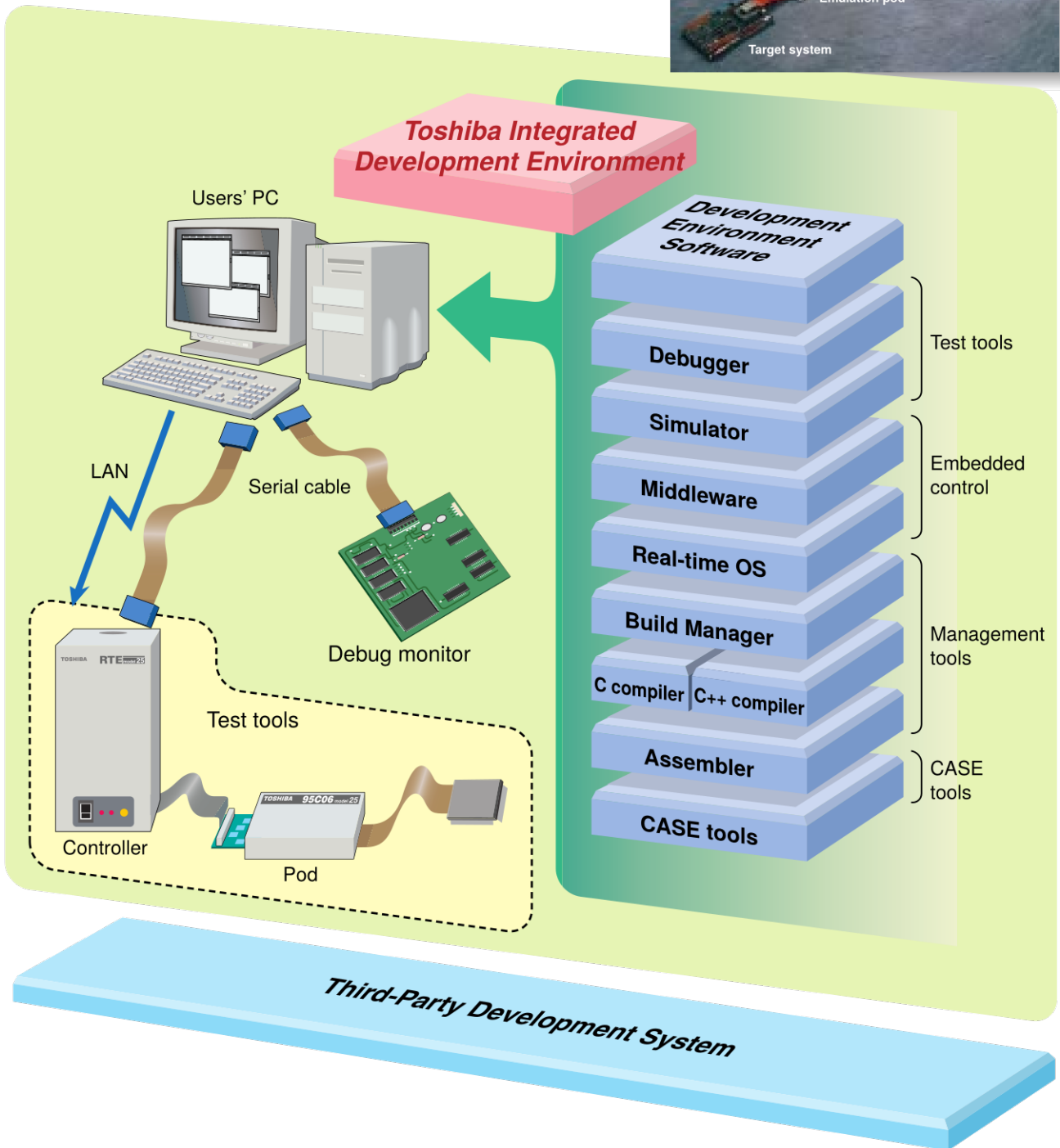
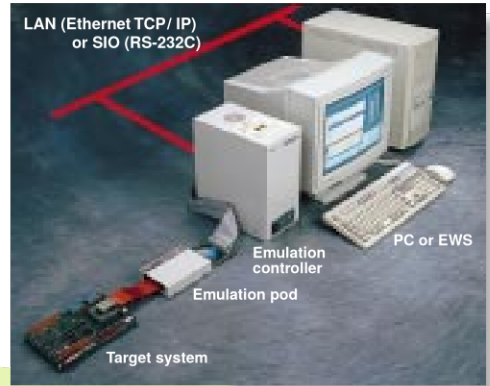

**Toshiba America  
Electronic Components, Inc.****Headquarters-Irvine, CA**

9775 Toledo Way, Irvine,  
CA 92618, U.S.A.  
Tel: (949)455-2000 Fax: (949)859-3963

**Altamonte Springs, FL(Orlando)**

600 S. North Lake Blvd., Suite 250,  
Altamonte Springs, FL 32701, U.S.A.  
Tel: (407)332-0966 Fax: (407)339-3777

**Deerfield, IL(Chicago)**

One Pkwy., North, Suite 500, Deerfield,  
IL 60015-2547, U.S.A.  
Tel: (847)945-1500 Fax: (847)945-1044

**Denver, CO**

8400 E. Prentice Englewood, CO 80111, U.S.A.  
Tel: (303)220-9848 Fax: (303)220-9856

**Edison, NJ**

2035 Lincoln Hwy. Ste. #3000, Edison  
NJ 08817, U.S.A.  
Tel: (908)248-8070 Fax: (908)248-8030

**Irvine, CA**

2 Venture Plaza, Suite 500, Irvine,  
CA 92718, U.S.A.  
Tel: (949)453-0224 Fax: (949)453-0125

**Microelectronics Center-Sunnyvale, CA**

1220 Midas Way, Sunnyvale,  
CA 94088-3509, U.S.A.  
Tel: (408)739-0560 Fax: (408)746-0577

**Norcross, GA(Atlanta)**

655 Engineering Dr. #160, Norcross,  
GA 30092, U.S.A.  
Tel: (404)368-0203 Fax: (404)368-0075

**Richardson, TX(Dallas)**

777 East Campbell Rd., Suite 650, Richardson,  
TX 75081, U.S.A.  
Tel: (214)480-0470 Fax: (214)235-4114

**Wakefield, MA(Boston)**

401 Edgewater Place, Suite #360, Wakefield,  
Essex, MA 01880-6229, U.S.A.  
Tel: (617)224-0074 Fax: (617)224-1095

**San Jose Engineering Center, CA**

1060 Rincon Circle, San Jose,  
CA 95131, U.S.A.  
Tel: (408)456-8900 Fax: (408)456-8910

**Toshiba Electronics Europe GmbH****Düsseldorf Head Office**

Hansaallee 181, D-40549 Düsseldorf  
Germany  
Tel: (0211)5296-0 Fax: (0211)5296-400

**München Office**

Büro München Hofmannstrasse 52,  
D-81378, München, Germany  
Tel: (089)748595-0 Fax: (089)748595-42

**Toshiba Electronics France S.A.R.L.**

Immeuble Robert Schumann 3 Rue de Rome,  
F-93561, Rosny-Sous-Bois, Cedex, France  
Tel: (1)48-12-48-12 Fax: (1)48-94-51-15

**Toshiba Electronics Italiana S.R.L.**

Centro Direzionale Colleoni  
Palazzo Perseo Ingr. 2-Piano 6,  
Via Paracelso n.12,  
1-20041 Agrate Brianza Milan, Italy  
Tel: (039)68701 Fax: (039)6870205

**Toshiba Electronics España, S.A.**

Parque Empresarial San Fernando Edificio Europa,  
1ª Planta, ES-28831 Madrid, Spain  
Tel: (91)660-6700 Fax: (91)660-6799

**Toshiba Electronics(UK) Limited**

Riverside Way, Camberley Surrey,  
GU15 3YA, U.K.  
Tel: (01276)69-4600 Fax: (01276)69-4800

**Toshiba Electronics Scandinavia AB**

Gustavslundsvägen 12, 2nd Floor  
S-161 15 Bromma, Sweden  
Tel: (08)704-0900 Fax: (08)80-8459

**Toshiba Electronics Asia  
(Singapore) Pte. Ltd.**

**Singapore Head Office**  
438B Alexandra Road, #06-08/12 Alexandra  
Technopark, Singapore 119968  
Tel: (278)5252 Fax: (271)5155, (270)6056

**Bangkok Office**

135 Moo 5 Bangkadi Industrial Park, Tivanon Rd.,  
Bangkadi Amphur Muang Pathumthani 12000, Thailand  
Tel: (2)501-1635 Fax: (2)501-1638

**Toshiba Electronics Trading  
(Malaysia)Sdn. Bhd.**

**Kuala Lumpur Head Office**  
Suite W1203, Wisma Conplant, No.2,  
Jalan SS 16/4, Subang Jaya, 47500 Petaling Jaya,  
Selangor Darul Ehsan, Malaysia  
Tel: (3)731-6311 Fax: (3)731-6307

**Penang Office**

Suite 13-1, 13th Floor, Menard Penang Garden,  
42-A, Jalan Sultan Ahmad Shah,  
100 50 Penang, Malaysia  
Tel: 4-226-8523 Fax: 4-226-8515

**Toshiba Electronics Asia, Ltd.****Hong Kong Head Office**

Level 11, Top Glory Insurance Building,  
Grand Century Place,  
No.193, Prince Edward Road West,  
Mong Kok, Kowloon, Hong Kong  
Tel: 2375-6111 Fax: 2375-0969

**Seoul Branch**

14/F, KEC B/D, 257-7 Yangjae-dong,  
Seocho-ku, Seoul, Korea  
Tel: (02)589-4334 Fax: (02)589-4302

**Seoul Branch, Gumi Office**

6/F, Ssangyong Investment Securities B/D,  
56 Songjung-Dong, Gumi City  
Kyeongbuk, Korea  
Tel: (0645)456-7613-6 Fax: (0546)456-7617

**Beijing Office**

Rm 714, Beijing Fortune Building,  
No.5 Dong San Huan Bei-Lu, Chao Yang District,  
Beijing, 100004, China  
Tel: (010)6590-8795 Fax: (010)6590-8791

**Chengdu Office**

Unit F, 18/F, 42 Wenwu Road  
Xinhua Avenue, Chengdu, 610017, China  
Tel: (028)675-1773 Fax: (028)675-1065

**Shenzhen Office**

Rm 3010-3012, Office Tower Shun Hing Square,  
Di Wang Commercial Centre, 333 ShenNan  
East Road, Shenzhen, 518008, China  
Tel: (0755)246-1582 Fax: (0755)246-1581

**Toshiba Technology Development  
(Shanghai) Co., Ltd.**

23F, Shanghai Senmao International Building, 101  
Yin Cheng East Road, Pudong New Area, Shanghai,  
200120, China  
Tel: (021)6841-0666 Fax: (021)6841-5002

**Tsurong Xiamen Xiangyu Trading Co., Ltd.**

8N, Xiamen SEZ Bonded Goods Market Building,  
Xiamen, Fujian, 361006, China  
Tel: (0592)562-3798 Fax: (0592)562-3799

**Toshiba Electronics  
Taiwan Corporation****Taipei Head Office**

17F, Union Enterprise Plaza Bldg. 109  
Min Sheng East Rd., Section 3, 0446 Taipei,  
Taiwan R.O.C.  
Tel: (02)514-9988 Fax: (02)514-7892

**Kaohsiung Office**

16F-A, Chung-Cheng Bldg., Chung-Cheng 3Rd.,  
80027, Kaohsiung, Taiwan R.O.C.  
Tel: (07)222-0826 Fax: (07)223-0046

**Toshiba Display Devices  
(Thailand) Co., Ltd.**

142 Moo 5, Bangkadi Industrial Park,  
Tivanon Rd., Pathumthani 12000, Thailand  
Tel: (2)501-1200 Fax: (2)501-1209

The information contained herein is subject to change without notice.

The information contained herein is presented only as a guide for the applications of our products. No responsibility is assumed by TOSHIBA for any infringements of patents or other rights of the third parties which may result from its use. No license is granted by implication or otherwise under any patent or patent rights of TOSHIBA or others.

TOSHIBA is continually working to improve the quality and the reliability of its products. Nevertheless, semiconductor devices in general can malfunction or fail due to their inherent electrical sensitivity and vulnerability to physical stress. It is the responsibility of the buyer, when utilizing TOSHIBA products, to observe standards of safety, and to avoid situations in which a malfunction or failure of a TOSHIBA product could cause loss of human life, bodily injury or damage to property. In developing your designs, please ensure that TOSHIBA products are used within specified operating ranges as set forth in the most recent products specifications. Also, please keep in mind the precautions and conditions set forth in the TOSHIBA Semiconductor Reliability Handbook.

The products described in this document may include products subject to the foreign exchange and foreign trade laws.

In Touch with Tomorrow  
**TOSHIBA**

**TOSHIBA CORPORATION**

**Electronic Devices Sales & Marketing Group**  
1-1, Shibaura 1-chome, Minato-ku, Tokyo, 105-8001, Japan  
Tel: (03)3457-3405 Fax: (03)5444-9324